

SWAROVSKI

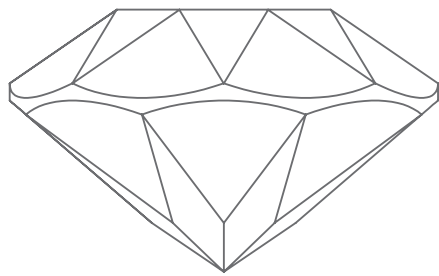

CRYSTAL COLLECTION

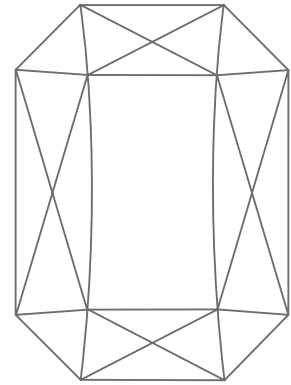
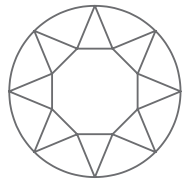
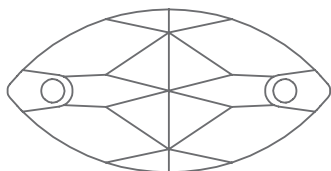
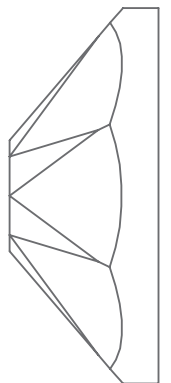

CRYSTAL COLLECTION

Valid from July 2014 until revoked

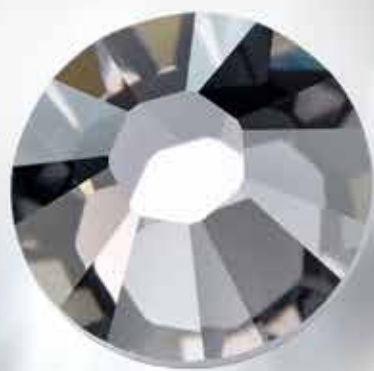



To help you succeed, we give you the edge.

Benefit from a range of expert trend, design,
application, and marketing support in the use of our
top-quality crystals, on a global and local level.





Seal your success

Be part of our exclusive Ingredient Branding program



Tangerine



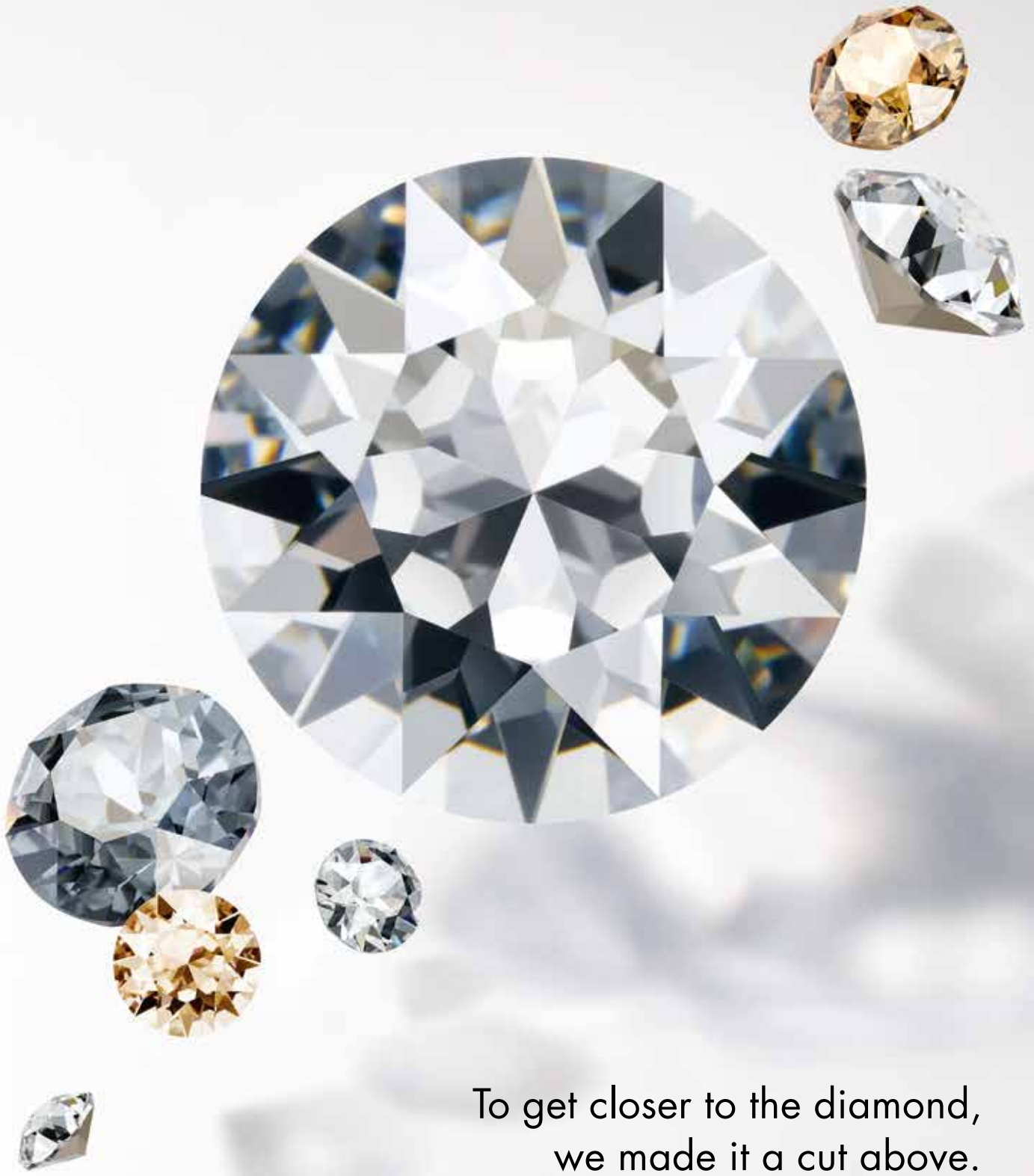

To get closer to the diamond,
we made it a cut above.

With its innovative cut and advanced foiling, XIRIUS offers you lasting
brilliance in a galaxy of sparkling colors and effects.

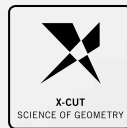



To predict the future,
we invented it.

Stay ahead with our Advanced Crystal. It is lead-free* and helps you to reach full compliance with current laws and regulations.



*Crystal glass and all other materials containing 0.009% lead or less.

Maison Martin Margiela for Swarovski
Crystalactite Pendants



BeCharmed





SWAROVSKI

COLLECTION

TAKE THOUSANDS OF CRYSTALS WHEREVER YOU GO

Inspiration is only an App away

Wherever you are, whatever you're looking for, search over 15,000 loose elements and 200,000 forward-integrated elements with Swarovski's inspirational new Crystal Collection App. Online or offline, stay app-to-date with the latest innovations and find popular classics – it's easy to install, easy to browse, easy to use.



SWAROVSKI.COM/COLLECTIONAPP

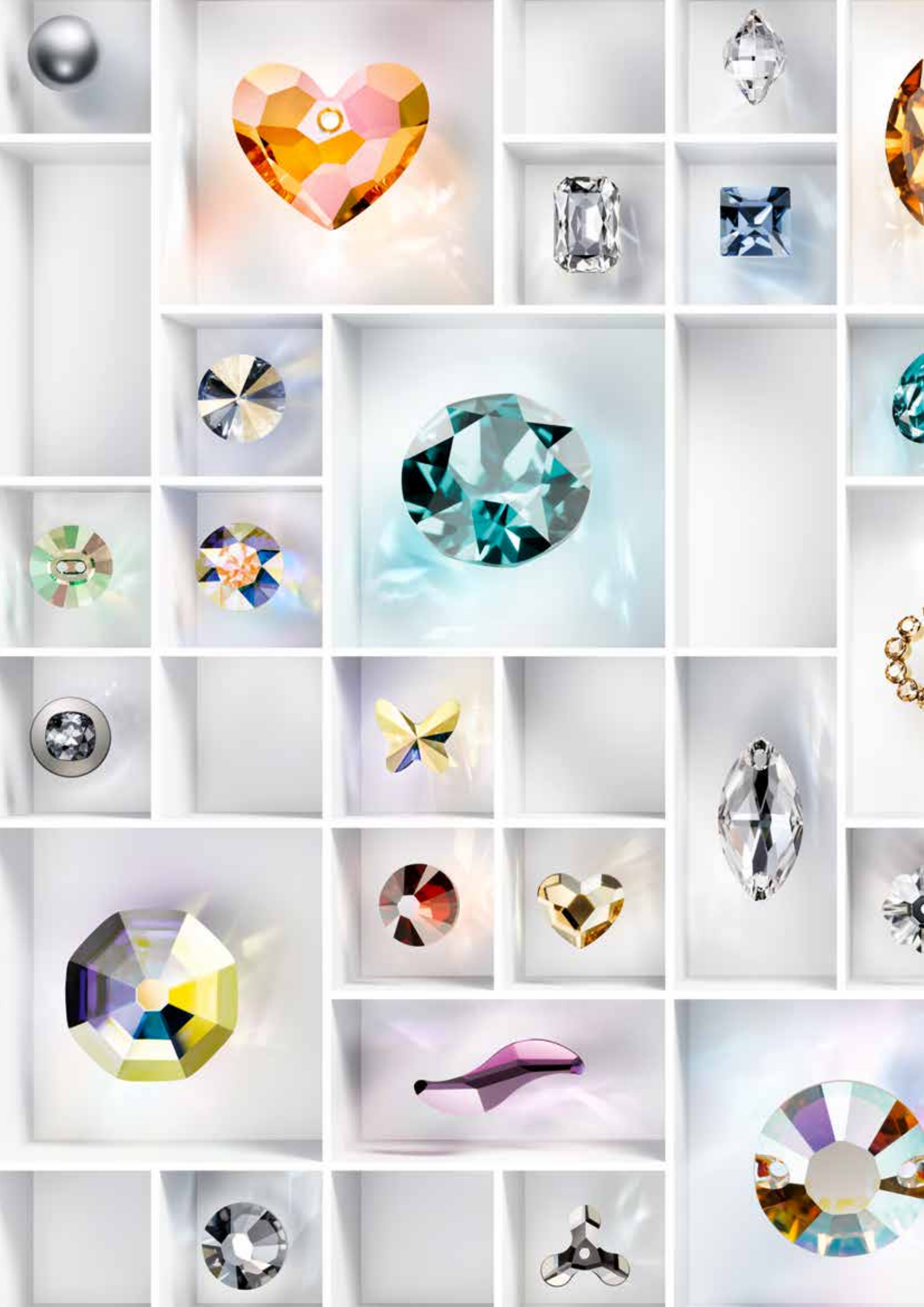

Contents

BASIC INFORMATION	22	07 PENDANTS	248
English	22	Summary	250
German	26	6000–6919	252
French	30	Product Details	283
Italian	34		
Spanish	38		
Portuguese	42	08 FLAT BACKS NO HOTFIX	288
Traditional Chinese	46	Colors & Effects, Summary	291
Simplified Chinese	50	2000–2858	292
Japanese	54	Product Details	307
Korean	58		
Russian	62		
		09 FLAT BACKS HOTFIX	310
01 DESIGNER EDITIONS	68	Colors & Effects, Summary	313
Summary	70	2000–2858	314
Product Details	80	Product Details	332
02 ROUND STONES	82	10 SEW-ON ARTICLES	336
Colors & Effects, Summary	85	Summary	339
1028–1480	86	3129–3708	340
Product Details	101	Product Details	351
03 FANCY STONES & SETTINGS	104	11 SELF-ADHESIVE ELEMENTS	354
Summary	106	Colors & Effects Crystal-it & Crystal Tattoos	357
Article Explanation	108		
4120–4884	109	Crystal-it	358
Product Details	160	Article Explanation	358
		Standard Collection	359
04 BEADS	170	75 000–75 081	359
Colors & Effects, Summary	173		
5000–5942	175	Crystal Tattoos	361
Crystal Mesh Ball	200	Article Explanation	361
Article Explanation	200	Standard Collection	362
Colors & Effects	200	70 008–71 401	362
40 512–40 519	202		
Complementary Products	205	Crystal Fabric-it	365
Product Details	206	Bandings	365
		Article Explanation	365
05 BECHARMED & PAVÉ	210	Colors & Effects	366
Summary	213	57 000	367
5890–5948	214	Motifs	368
BeCharmed Pavé	218	Article Explanation	368
Article Explanation	218	Standard Collection	369
80 101–81 201	219	57 351, 57 352, 57 353	369
77 510, 77 512	228		
BeCharmed Bracelet	229	Crystaltex-it	370
Article Explanation	229	Bandings	370
80 000	229	Article Explanation	370
Pavé Ball	230	62 000, 62 010, 62 011	371
Article Explanation	230	Motifs	372
86 001	232	Article Explanation	372
Product Details	233	Standard Collection	373
		66 001, 66 021, 66 036	373
06 CRYSTAL PEARLS	234	Product Details	373
Colors	236	Motifs	374
Summary	238	Article Explanation	374
5810–5860	240	Crystal Inspirations Collection	375
Product Details	246	Fall/Winter 2010/11	375
		65 281	375
		Chaton Bandings	376
		Article Explanation	376
		62 030, 62 031	377
		Chaton Motifs	379
		Article Explanation	379

Contents

Standard Collection	380	57 195–57 324	486
85 102–85 132	380	Fall/Winter 2012/13	486
		57 325–57 332	486
Crystal Rocks-it & Crystal Fine Rocks-it	381	Fall/Winter 2013/14	487
Article Explanation	381	57 334	487
Colors & Effects	382	Spring/Summer 2014	487
72 000 – 72 999, 74 000 – 74 999	383	57 347	487
		News	488
Special Motif Service	384	57 348, 57 349	488
		Lingerie	488
		57 350	488
		Special Motif Service	489
<hr/>			
12 TRANSFERS	388	Crystal Rocks	490
Colors & Effects	390	Article Explanation	490
Flat Backs for Transfers	391	Colors & Effects	491
Article Explanation	412	Standard Collection	493
		72 000–72 032	493
Standard Collection	415	Crystal Inspirations Collections	495
Motifs & Rows	416	Spring/Summer 2011–Spring/Summer 2012	495
10 010–12 967	416	72 008–72 016	495
18 117–726 198	425	Fall/Winter 2012/13	496
All-over Motifs	427	72 017	496
10 482–11 461	427	Spring/Summer 2014	496
		72 012	496
Crystal Inspirations Collections	431	Fall/Winter 2014/15	496
Spring/Summer 2007–Fall/Winter 2013/14	432	72 033	496
12 160–12 928	432	Special Motif Service	497
Spring/Summer 2014	448		
12 930–12 977	448	Crystal Fine Rocks	498
Fall/Winter 2014/15	452	Article Explanation	498
12 978–13 010	452	Colors & Effects	499
Spring/Summer 2015	455	Standard Collection	501
13 011–13 048	455	74 000–74 023	501
		Special Collections	503
Special Collections	461	Denim	503
Lingerie	462	74 016	503
18 525–18 921	462	Lingerie	503
Interior Motifs	463	74 018	503
12 559	463	Crystal Inspirations Collection	504
Playful Motifs	463	Fall/Winter 2014/15	504
18 680–18 904	463	74 017–74 022	504
Denim	465	Special Motif Service	505
18 905–18 925	465		
Interior Textiles – Cushion Collection	466	Crystaltex	506
18 866, 18 868	466	Bandings	506
Special Motif Service	467	Article Explanation	506
		Available Base Material & Stone Configurations	507
Chaton Leather	469	62 000–62 020	508
Article Explanation	470	Banding Motifs	509
Colors & Effects	472	Article Explanation	509
Standard Motifs	474	66 000–66 043	510
101 601–101 734	474	Standard Collection	511
		66 001–66 014	511
<hr/>		Crystal Inspirations Collections	512
13 SYNTHETICS HOTFIX	476	Fall/Winter 2010/11	512
Crystal Fabric	478	66 043	512
Application Examples	478	Product Details	512
Bandings	478	Crystaltex Motifs	513
Colors & Effects	479	Article Explanation	513
57 000	480	Available Base Material Colors	514
Motifs	481	65 000 onwards	514
Article Explanation	481	Motifs	516
Standard Collection	482	Standard Collection	516
57 125–57 346	482	65 011–65 337	516
Crystal Inspirations Collections	486	Crystal Inspirations Collection	518
Spring/Summer 2007–Spring/Summer 2012	486		

Contents

Fall/Winter 2010/11–Spring/Summer 2012	518	52 000–52 501	582
65 282–65 307	518	Falt Back Bandings	584
Chaton Bandings	519	55 000–55 501	584
Article Explanation	519	Spike Bandings	586
62 030, 62 031	520	Article Explanation	586
Chaton Motifs	522	52 300–52 401	587
Article Explanation	522	Chaton & Flat Back Motifs	588
85 100 onwards	523	Article Explanation	588
Crystaltex Chaton Motifs	524	Chaton Motifs	590
Standard Collection	524	52 100–52 608	590
85 102–85 137	524	Standard Collection	591
Crystal Inspirations Collection	526	52 114– 52 610	591
Fall/Winter 2012/13	526	Flat Back Motifs	592
85 100–85 135	526	55 100–55 618	592
Special Motif Service	527	Standard Collection	593
		55 126–55 621	593
		Special Collection	594
		Lingerie	594
		55 620	594
		Special Motif Service	595
14 PLASTIC TRIMMINGS	528	Metal Components	596
Basic Bandings	530	Article Explanation	596
Article Explanation	530	Rivets	597
50 002, 50 003, 50 004	532	53 000–53 008	597
Fishnet Bandings	533	Crystal Pearl Rivets	600
Article Explanation	533	53 400, 53 401, 53 402	600
50 300	534	Square Rivets	601
Decorative Bandings	535	53 500, 53 501, 53 502	601
Article Explanation	535	Chessboard Rivets	602
50 100–50 108	537	53 600	602
Plastic Components	539	Star Rivet	603
Mini Rondelles	539	53 700	603
Article Explanation	539	Spike Rivets	604
4720/101, 4720/102	540	53 010–53 503	604
		Back Parts for Rivets	605
		53 007, 53 009	605
		Roses Montées	606
		53 100, 53 102, 53 103	606
		Chaton Montées	607
		53 200, 53 201, 53 203	607
		Rose Pins	608
		53 301–53 304	608
		Chessboard Pin	609
		53 310, 53 311	609
		Rhombus Pin	609
		53 320	609
		Crystal Stud	610
		53 730, 53 731	610
		17 CRYSTAL MESH	612
		Article Explanation	612
		Crystal Mesh Standard	616
		40 000, 40 001	616
		Crystal Mesh XL	618
		40 100, 40 101	618
		Colors & Effects	619
		Crystal Mesh Metallisée	620
		40 200, 40 201	620
		Crystal Aerial Mesh	622
		40 400, 40 401	622
		Colors & Effects	624
		Crystal Mesh Bandings	626
		Article Explanation	626
		40 701	627
		Crystal Mesh Motifs	628
16 METAL TRIMMINGS	578		
Chaton & Flat Back Bandings	580		
Article Explanation	580		
Chaton Bandings	582		

Contents

Article Explanation	628	Rondelles	721
Standard Collection	629	Article Explanation & Ordering Example	722
40 756–40 924	629	77 503–77 806	723
Special Collection	631	Product Details	732
Denim	631		
40 792	631	Linked Findings	735
Product Details	632	Chains	736
Special Motif Service	633	Ordering Example	736
		90 005–90 022	737
18 CUPCHAINS & FINDINGS	634	Web Sheets	741
Plating Details	636	Ordering Example	741
Colors & Effects	636	98 001, 98 002	742
Base Items	637	Web Rows	744
		Ordering Example	744
Single Stone Settings	639	99 001, 99 002	745
Article Explanation & Ordering Example	640	Product Details	747
11 004–19 905	641		
Cupchains & Brass Components	661		
Article Explanation & Ordering Example	662	19 KNOBS, HANDLES & CO	748
21 004–28 002	664	Summary	751
02 09S–01 256	666	Balls	752
Product Details	688	7100–7130	752
		Forward-integrated	753
Multi Stone Settings	691	7155, 7160, 7165	753
Article Explanation & Ordering Example	692	Lever Handles	754
31 E02–47 603	694	7300–7307	754
		Centerparts	755
Channels	709	7312, 7322, 7323	755
Article Explanation & Ordering Example	710	Installation	756
53 300–57 700	711	Product Details	757
Metal Buttons	715		
Ordering Example	716	Table of Sizes	759
60 408–61 019	717		

Why Swarovski

EXCELLENCE, THROUGH INNOVATION AND ORIGIN

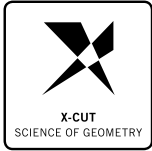

X-CUT

Swarovski's unique X-Cut technology is based on scientific principles developed by the Gemological Institute of America for grading diamonds. Advanced optical measurement and high-precision manufacturing deliver premium cuts characterized by the interplay of multilayered surfaces and angles, with XILION and XIRIUS as the most prominent examples. This 'science of geometry' raises crystals' brightness, fire, and scintillation to an unmatched level of brilliance.



PLATINUM PRO

Using its vast research and technological capability, Swarovski has set a new standard in the lifespan of crystals with its new advanced Platinum Pro foiling technique. Platinum Pro is not only resistant to environmental damage from chlorine, salt water, and perfume—it can also withstand processes such as soldering and electroplating, giving it unprecedented durability.



HOTFIX GLUE

Swarovski's revolutionary Hotfix technology offers a flexible and durable way to apply crystals. The glue's broad activation window, beginning at already low temperatures, makes it possible for customers to align the application time and temperature in a way that is appropriate to their specific requirements. Hotfix's suitability for all textiles commonly used in the industry means that it is ideal for a vast array of clothing, interiors, and accessories. Its adhesive strength and washability make it the preferred choice of international brands and designers.



CRYSTALS – MADE IN AUSTRIA

Austria has become synonymous with quality. With a highly skilled workforce, supported by fair working conditions in accord with the high environmental standards, it has built a reputation for technical expertise, precision engineering, and reliability. Originally, it was the country's natural abundance of water that prompted Daniel Swarovski, in 1895, to establish his company in Wattens, high in the Austrian Alps. It was here that sustainable hydroelectric power could be used to drive his machinery—and his vision. Swarovski continues to invest in the future, leading this culture of innovation, sustainability, and respect for individual wellbeing that underpins Austria's success.

PREMIUM, BY SERVICE AND DESIGN



DESIGN SERVICE

With its international reputation for creative excellence, Swarovski is at the forefront of design innovation across the world, offering exceptional service provided by the industry's best creative talent. Throughout a global network of Design Centers, highly experienced teams provide first-class creative direction encompassing trend research, design, technical design, and consulting. It is Swarovski's thoroughness, together with its passion for design, which makes it successful in translating customer requirements into creative commercial proposals.



APPLICATION SERVICE

Swarovski's comprehensive range of application services falls under three core facilities: the Technical Enquiry Service, Swarovski's unique global technical database that facilitates the sharing of knowledge with customers around the world; Certified Application Partners, which offer technical and production expertise to business customers at a local level; and Application Training, which trains customers in standard application techniques. This comprehensive approach means customers benefit from the extensive experience of leading international experts, as well as internal specialists.



GLOBAL SERVICE

Swarovski sells its products in over one hundred countries. Committed to providing dedicated personal assistance, Swarovski structures its operations around a global sales force supported by Customer Care Centers with a deep understanding of local markets. Through its collaborations with certified Application Partners, Swarovski provides worldwide application support to its customers. Likewise, Swarovski's customers profit from its global network of Design Centers that provide unparalleled creative direction, from very specific modular aspects to fully comprehensive solutions.



DESIGNER EDITIONS

Beginning with Christian Dior in the 1950s, and continuing with today's top designers and brightest rising stars, Swarovski is proud of its long history of creative collaboration with artists, artisans, and designers from all areas of jewelry and fashion. Crystal has long been a dynamic source of inspiration for creative minds—enchanted by its myriad design possibilities, their visionary ideas are transformed into exclusive cuts and unique designs for Swarovski crystal.

Why Swarovski

COMPLIANCE, WITH INTEGRITY



ADVANCED CRYSTAL

Swarovski's patented lead-free* formula has changed the DNA of crystal while still offering the same sparkle, dependability, and variety for which Swarovski is famous. If you haven't noticed a difference, that's probably because

when it comes to the ADVANCED CRYSTAL standard it's what you don't see that matters. Carefully selected raw materials are made into products compliant with crucial current laws and regulations governing the use of certain substances in finished products in the most relevant segments of Swarovski's customers' businesses. Swarovski's new and innovative formula offers peace of mind for business partners in the ever-stricter international regulatory environment.



CLEAR

Swarovski's internal compliance program, called CLEAR, summarizes the chemical requirements of the most critical laws and regulations regarding the restriction and prohibition of substances in its customers' most

relevant product segments. These particularly include jewelry and accessories, textiles, interiors, packaging, electronics, and children's products. The program and its guidelines are subject to regular legal monitoring. Likewise, Swarovski requires all suppliers to fully declare their raw materials and to take part in the CLEAR program. CLEAR provides customers with the comfort of trust that all products have undergone a reasonable testing program and are found to comply with their requirements.



OEKO-TEX

Customers can have confidence in Swarovski's products. As a major supplier to the textile industry, the majority of Swarovski's product range has been certified according to the Oeko-Tex® Standard 100 Class II. This quality

label sets limits for potentially harmful substances in textile products, particularly those that are in direct contact with skin.

COLLECTIONS

Swarovski is the leading manufacturer of precision-cut crystals that are used in the fashion and jewelry industries as well as in the world of lighting design, architecture and interior. Crystals from Swarovski have become an indispensable material for the creations of international designers. Swarovski is selling its loose crystal elements and forward-integrated solutions to the worlds of fashion and design under the product brand Swarovski.

This Collection is providing a complete overview of the whole product range. All product information is also available as digital download, via our Business website WWW.SWAROVSKI.COM/PROFESSIONAL, and in the new Collection App for iPad available on iTunes in April 2014.

A dedication to perfection and innovation has been a cornerstone policy of the company since its foundation in 1895. This pursuit of excellence includes Swarovski's commitment to trend research, which results in the creation of trend-relevant crystal elements as well as new colors and effects that are added to the assortment every Spring/Summer and Fall/Winter fashion season. Those innovations and seasonal line extensions are featured in comprehensive main launch communication packages each February and September, and a pre-season launch package in May. Dedicated to remaining the world leader in precision-cut crystal, Swarovski also offers its customers segment specific collections and customized product solutions as well as trend support and application services. For more information concerning Swarovski products, services and sales materials, please contact your nearest Swarovski sales office.

ORDERING

Please contact your nearest Swarovski sales office for ordering products. Registered customers also have the convenient option to order online via the e-commerce service of WWW.B2B.ECOMMERCE.SWAROVSKI.COM. In addition to providing an online ordering facility, the website also includes valuable product information, availability, delivery details etc. Contact your Swarovski sales office to register for this service.

APPLICATION INFORMATION

Thanks to their outstanding quality and with the help of specially developed application techniques, Swarovski can be processed easily and quickly with high quality.

The Application Manual provides in-depth information regarding all current application techniques and the technical services provided by Swarovski. It contains detailed illustrations and instructions for correct soldering, plating, gluing, Ceralun™, sewing, embroidery, Hotfix and mechanical application as well as useful care instructions and information about the required machines, tools and aids and their suppliers. The manual is available in various international languages.

All detailed and up-to-date information regarding the Application Manual is also available on the website WWW.SWAROVSKI.COM/PROFESSIONAL. The application techniques are demonstrated in animations and videos.

Please contact your local Swarovski representative to gain access to the internal section of the Business website.

For specific questions regarding the application techniques, please contact your local Swarovski sales office.

PART-CUT AND UNCUT ARTICLES

The standard collection not only includes cut articles but also articles that are only part-cut or uncut.

/3

The crystal has not been cut, but has pressed facets.



/4

The crystal has not been cut and has no facets (e.g. art. 2080/4).

SIZES

Various measurement abbreviations are used to classify the jewelry stones.

**PP, SS**

Pearl Plate (PP), Sieve Size or Stone Size (SS) for round crystals. Please also refer to the conversion table located at the back of the Collection ("Open to See Sizes").

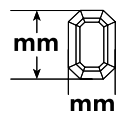
**mm**

Metric measurement in millimeters.

COLORS & EFFECTS

Classic Colors & Effects

The classic assortment offers a wide range of crystal colors, including all the classical jewelry colors. Creative grouping of the available colors can achieve combinations that are not only original but also rich in nuances.

Exclusive Colors & Effects

The exclusive assortment includes crystal colors that guarantee up-to-date trend relevance and are exclusively launched by Swarovski. Each color, developed in cooperation with international trend agencies, bears the unmistakable hallmark of Swarovski quality and creativity. Exclusive colors and effects can be recognized in the product matrices as underlined names.

Colors and effects can appear different when illuminated with different light sources. Swarovski uses standard light source D50 for color decision and comparison.

Special color cards for several product groups are located at the beginning of the chapters.

Colors and Effects Categories

In the product matrices, colors and effects follow a specific segmentation:

Crystal
Crystal (001), foiled or unfoiled
Colors
Plain Colors
Available plain colors
Opal Colors
Available opal colors
Crystal Blend Colors
Available Crystal Blend Colors
Ceramics
Available Ceramics Colors
Colors
Colors
Available plain colors
Gemcolors
Available Gemcolors
Neoncolors
Available Neoncolors
Crystal Effects or Color Effects
Transparent Effects
Available transparent effects
Metallic Effects
Available metallic-appearing effects
Full Coating
Available Full Coating effects
Crystal Patina
Available Crystal Patina effects

For Crystals

For Crystal Pearls

METBL	Metallic Blue
MLGLD	Metallic Light Gold
MOL	Moonlight
NUT	Nut (only on Jet)
REDM	Red Magma
ROGL	Rose Gold
SAT	Satin
SSHA	Silver Shade
TRA	Transmission

Translucent Effects

(Vacuum coating on the reverse side of the crystal, effect shines through the transparent crystal)



Effect Code	Name
BBL	Bermuda Blue
HEL	Heliotrope
MBL	Meridian Blue
SINI	Silver Night
TAB	Tabac
VL	Vitrail Light
VM	Vitrail Medium
VOL	Volcano

Patina Effects

Effect Code	Name
BLAPA	Black Patina
GOLPA	Gold Patina
ROSPA	Rose Patina
SILPA	Silver Patina
WHIPA	White Patina

Variations on Surface Effects



2x
Both sides of the stone are treated with an effect (e.g. AB 2).



B
Effects on three sides of a cube shape (e.g. AB B).



V
The effect is used in reverse. A surface effect is used like a translucent effect (e.g. SSHA V – Silver Shade on the reverse side).



Z
Only a part of the stone is treated with an effect (e.g. HEL Z).

FC (Full Coated)

Improved technology creates perfectly homogeneous, all-round application of high-intensity metallic effects in the Bead assortment (art. 5000).

CAL 'V' SI & CAL 'VZ' SI

The effect CAL (Comet Argent Light) will be also used as a mirror coating on the reverse side of the crystal instead of standard foilings (A, F, ...) in special cases (e.g. Knobs, Handles & Co.).

/G

Article with partly (PF) or fully frosted (FF) surface (e.g. art. 2611/G)

PA (Patina)

Innovative technology creates partly coated application of adapted effects. Its historical edge and "used" look gives it a timelessness without losing the crystalline aspect.

EFFECTS

Vacuum coating processes on the surface of the crystal produce either a special surface or a translucent effect, according to the application methods used.

Please find below a list of all Swarovski effects followed by an explanation of the special vacuum coating processes.

Surface Effects



(Vacuum coating on the surface of the crystal)



Effect Code	Name
AB	Aurore Boreale
ANTP	Antique Pink
API	Astral Pink
BLSH	Blue Shade
BRSH	Bronze Shade
CAL	Comet Argent Light
COP	Copper
DOR	Dorado
GSHA	Golden Shadow
HEM	Hematite (only on Jet)
IRIG	Iridescent Green
LISH	Lilac Shadow
LUMG	Luminous Green

Special Surface Effects

Swarovski has been able to achieve various special surface effects by using special chemical and mechanical processes on the surface of the crystals.

		<i>Effect Code</i>	<i>Name</i>
MAT	COS	MAT	Matt Finish
		COS	Cosmojet

The Matt Finish effect is achieved by performing a chemical matting process on the entire surface of the crystal. Small variations in the size of the articles may occur as a result of this chemical process.

Using a special process, the outer facets of Flat Back Roses can be blackened. The Cosmojet effect is only possible for the color Crystal (001).

FOILING

Foiling is the process of mirror coating the reverse side of the crystals.



Silver Foiling (A)

A silver mirror finish for XIRIUS and XILION Hotfix articles only.



Platinum Pro Foiling (F)

A silver mirror finish that is coated with a platinum colored protective layer of highest quality. The Platinum Pro Foiling is not only resistant to environmental damage from chlorine, salt water, and perfume – it can also withstand processes such as soldering and electroplating, giving it unprecedented durability.



Aluminum Foiling (M)

An aluminium mirror finish is applied using a vacuum coating process.



Protective Layer (P) for Beads and Pendants

Protective layer is a transparent lacquer system that is applied over the effects. This lacquer is designed to protect the effects from scratches, fingerprints, and other damage and also helps to prevent moisture that can lead to corrosion (e.g. from perspiration) penetrating into the effect layer when jewelry is designed to incorporate Crystal Stones that are not set in casings/settings.



Unfoiled (U)

HOTFIX TECHNOLOGY

Hotfix (HF)

Hotfix technology involves applying specially developed glue onto the reverse side of Flat Backs. The glue, which is extremely flexible, is activated at a temperature of 120°C, with the flexibility to be applied up to 170°C, and bonds with the carrier material. The crystal element is permanently fixed onto the carrier material during the cooling off process.

Hotfix Transparent (HFT)

This variant of the Hotfix technology is a patented bonding agent that is applied to the reverse side of non-mirror finished Flat Backs resulting in an interesting “raindrop” effect in which the crystal takes on the color of the carrier materials.

No Hotfix (No HF)

Hotfix articles are also available as No Hotfix articles that do not have glue applied onto the reverse side. For more information please contact your relevant Customer Service.

CUSTOMIZED SOLUTIONS

Swarovski offers customized solutions in addition to the standard collection*.

The following customized solutions can be offered:

- **Standard articles in non-standard colors and effects**
- **Standard articles with motives/prints**
- **Non-standard cuts and sizes**
- **Customized product development**
- **Customized forward integrated elements**

Due to technical reasons, special productions may be subject to a minimum order quantity, while standard articles are available as individual packs. Special productions are subject to a possible over- or under delivery of 10%. Should the value of an order item fall below a certain minimum at standard articles in non-standard colors and effects (see the Swarovski Price List for details), an additional surcharge of 20% will be applied. Please note that special productions may be subject to individual delivery times.

For more information and consultancy regarding special productions please contact your relevant Customer Service.

* Available to all our customers. Availability of special productions may be limited in technical feasibility and if our Terms and Conditions are applied.

LAWS, REGULATIONS, NORMS & STANDARDS

The composition of Advanced Crystal and forward-integrated products in the Advanced Crystal standard is compliant with regulatory industry norms and laws regarding the restriction or prohibition of certain substances for finished products in the most relevant segments of our customers' business, including:

General

- Lead in surface coatings as set out in 16 CFR 1303

Regulations for Jewelry

- European nickel release limits for jewelry as set out in REACH regulation 1907/2006/EG
- European cadmium content limits for jewelry as set out in REACH regulation 1907/2006/EG
- China Industrial Standard QB/T 2997-2008 Adornment with Precious Metal Coating
- Limits for lead in jewelry and surface coatings as set out in California S.B. 646, amending California Health & Safety Code 25214.1 et seq. (commonly known as California Jewelry Law)
- China GB 28480-2012 adornment-provision for limit of baneful elements

Regulations for Children's products (3-14 years)

- Lead limit as set out in 16 CFR 1500 (U.S. Consumer Product Safety Improvement Act, CPSIA), U.S. 74 Fed. Reg. 43031
- Directive 2009/48/EU, Toy Safety, annex II, section III.13 – heavy metal migration limits
- ASTM F963-11, Toy Safety section 4.3.5.2., heavy metal migration limits
- ASTM F2923-11, Standard Specification for Consumer Product Safety for Children's Jewelry
- Cadmium migration limits as set out in Illinois 430 ILCS 140, amended by H.B. 5040 – Cadmium-Safe Kids Act
- Cadmium migration limits as set out in Minnesota Statutes 325E.3891 – Cadmium in Children's Jewelry
- California S.B. 929, amending the California Health & Safety Code 25241.1 et seq.*
- Connecticut Gen. Stat. 21a Sec 21a-12d – Cadmium in Children's Products*
- Maryland Code 6-1402 – Cadmium in Children's Jewelry*
- Korean Quality Management and Safety Control of Industrial Products Act*

Electrical and Electronic Products

Heavy metal content limits as set out in European RoHS (Directive 2011/65/EC)*, Korean Act for Resource Recycling of Electrical/Electronic Products and Automobiles*, and Japanese Industrial Standard (JIS)*

Packaging

Heavy metal content limits as set out in European Packaging Directive 94/62/EC* and Toxics in Packaging Regulations as adopted by certain U.S. states (TPCH)*

Textile Products

Crystals from Swarovski, with only very few exceptions are certified to Oeko-Tex Standard 100 Class II (products in contact with skin), an international quality label for harmless textiles. For detailed information as to which crystals from Swarovski comply with Oeko-Tex Standard 100, please visit WWW.SWAROVSKI.COM/PROFESSIONAL

- * Please note that the following crystal colors are not compliant with the regulations marked above: Citrine, Fireopal, Hyacinth, Light Siam, Palace Green Opal, Siam, and Sun.

This is valid for current regulations (as of March 2014), but it must be considered that laws and regulations may change in the future and vary from country to country. Therefore we cannot guarantee to fulfill all regulations. For updated information please visit our B2B website. The final responsibility regarding compliance for third-party finished products lies with the manufacturers of the finished product.

WARNING NOTICES**General Warning**

Loose crystals may present a small parts hazard to young children, particularly children under three years old. Depending on the size of the crystal and any attached material (such as glue, fabric, etc.), children may choke on, inhale, swallow, or insert the crystal into their noses. Magnetic products with crystal applications pose a particular risk of serious intestinal injury if ingested. The application techniques as stated in the Application Manual do not guarantee that crystals will not come loose. For each application, the manufacturer must determine whether the product meets the relevant requirements related to small parts hazards and assess any risk it may pose to small children. Failure to follow Swarovski's care instructions may result in damage to the crystal, which could pose a risk of laceration or other harm.

Warning for Crystal Tattoos

Crystal Tattoos may be applied on healthy skin only. Do not adhere to eyes or on mucous membranes. Crystal Tattoos are not recommended for young children. Loose crystals may present a small parts hazard to young children, particularly children under three years old. If a crystal comes loose, depending on the size of the crystal, children may choke on, inhale, swallow, or insert the crystal into their noses.

Warning for Tableware

Application of loose crystals to tableware presents a potential risk of aspiration, choking, swallowing, or tooth damage should crystals become loose. To reduce this risk, crystals should never be applied to any surface of tableware likely to come in contact with food or the mouth, and crystals should never be placed on any tableware intended for use by children. Tableware with crystals intended for decorative use only should be marked as such. To avoid dishwasher damage, tableware decorated with crystals should be washed by hand. The application techniques or suggestions in this manual do not guarantee that crystals will not come loose. For each application, the manufacturer must determine whether the product meets relevant requirements related to small parts hazards or use in food contact items and assess any risk it may pose to users.

The use of crystals (which may contain restricted substances deemed hazardous under local laws) and adhesives on tableware is subject to legal restrictions in specific countries. The customer is fully responsible to comply with these country-specific provisions and shall defend, indemnify, and hold Swarovski harmless from any and all third-party claims based on product liability or otherwise relating to uses of Swarovski products and waives all its own claims against Swarovski.

Unsuitable Applications

Crystals from Swarovski are intended for use in the fields of fashion, jewelry, accessories, textile products, and for interior décor. Due to their physical properties, crystals from Swarovski are unsuitable for other uses (e.g. gluing onto teeth, using crystals on or near mucous membranes, and other unsafe uses). The customer shall defend, indemnify and hold Swarovski harmless from any and all third-party claims based on product liability or otherwise relating to uses of Swarovski products purchased by the customer, and waives all its own claims.

Responsibility of User

Any oral, written, or test-based advice that Swarovski provides regarding techniques for application of its products are recommendations based on Swarovski's current knowledge and the information provided by its suppliers. Such advice does not discharge the customer from carrying out its own tests of techniques it proposes to use and their suitability for the intended application. The application, use, and processing of these techniques and products are solely the user's responsibility.

COLLECTIONS

Swarovski ist der weltweit führende Hersteller von präzise geschliffenen Kristallen, die in der Mode- und Schmuckindustrie ebenso zum Einsatz kommen wie in der Lichtplanung, der Architektur und in der Innenraumgestaltung. Für internationale Designer ist Kristall von Swarovski ein unverzichtbarer Bestandteil ihrer Schaffenskraft. Seine losen Kristallelemente und vorwärtsintegrierten Lösungen verkauft das Unternehmen unter der Produktmarke Swarovski. Diese Collection beinhaltet das gesamte Produktsortiment. Alle Produktinformationen sind erhältlich als digitaler Download, über unsere Business Webseite WWW.SWAROVSKI.COM/PROFESSIONAL sowie auch in der neuen Collection App für iPad, die ab April 2014 bei iTunes erhältlich ist. Seit der Firmengründung im Jahr 1895 sind Perfektion und Innovation die Grundpfeiler des Unternehmens. Dieses Streben nach Einzigartigkeit umfasst auch visionäre Trendforschung, aus der zweimal im Jahr – jeweils pünktlich zur Frühjahr-/Sommer- und Herbst-/Wintersaison neue Komponenten, Farben und Effekte erscheinen. Diese Neuheiten werden dem Markt jeweils im Februar und September in umfassenden Kommunikationspaketen sowie im Mai in einem Launchpaket für die Vorsaison vorgestellt. Als Marktführer von geschliffenem Kristall bietet Swarovski seinen Kunden zusätzlich segmentspezifische Kollektionen, kundenindividuelle Produktlösungen sowie Trend- und Applikations-Support an. Für mehr Informationen und Details zu Swarovski Produkten, Services und Verkaufsmaterialien kontaktieren Sie bitte Ihre nächste lokale Swarovski Vertriebsgesellschaft.

PRODUKTBESTELLUNG

Für Produktbestellungen kontaktieren Sie bitte die Ihnen zugeordnete lokale Swarovski Vertriebsgesellschaft. Darüber hinaus steht registrierten Kunden unter WWW.B2B.ECOMMERCE.SWAROVSKI.COM unser bequemer E-Commerce Service zur Verfügung, der neben der Bestellmöglichkeit auch wertvolle Informationen über Produkte, Verfügbarkeiten, Lieferdetails usw. bietet. Registrierungen werden von Swarovski durchgeführt.

APPLIKATIONSINFORMATIONEN

Swarovski Kristall lässt sich dank seiner hervorragenden Qualität und mit Hilfe von speziell entwickelten Applikationsverfahren schnell, einfach und mit einem hochwertigen Finish verarbeiten.

Im Application Manual finden Sie Informationen über alle gängigen Applikationsverfahren sowie über die von Swarovski angebotenen technischen Serviceleistungen. So enthält dieses ausführliche Beschreibungen und Illustrationen über Löten, Galvanisieren, Kleben, Ceralun™ Applikation, Hotfix Applikation, Nähen, Sticken und mechanische Applikation sowie nützliche Pflegehinweise und Informationen zu erforderlichen Maschinen, Werkzeugen und Hilfsmitteln inkl. Lieferantenverzeichnis. Das Manual ist in verschiedenen Sprachen erhältlich.

Alle Informationen des Application Manuals sind außerdem auf der Business Website WWW.SWAROVSKI.COM/PROFESSIONAL ausführlich und stets aktuell angeführt. Zusätzlich werden Applikationsverfahren mit Animationen und Videos veranschaulicht. Zugang zum internen Bereich der Business Website kann jederzeit bei Ihrer lokalen Swarovski Vertriebsgesellschaft angefragt werden.

Für spezielle Applikationsanfragen wenden Sie sich bitte an Ihre lokale Swarovski Vertriebsgesellschaft.

UNGESCHLIFFENE UND TEILSCHLIFFARTIKEL

Das Sortiment an Schmucksteinen beinhaltet auch Artikel, die nur teilweise oder ungeschliffen sind.

/3

Der Kristall ist ungeschliffen, weist jedoch gepresste Facetten auf.



/4

Der Kristall ist nicht geschliffen und hat keine Facetten (z. B. Art. 2080/4).

GRÖSSEN

Um Schmucksteine klassifizieren zu können, werden verschiedene Abkürzungen von Maßeinheiten verwendet.



PP, SS

Perlengröße (PP - „Pearl Plate“), Kristallgröße (SS - „Stone Size“) bei runden Kristallen. Eine Umrechnungstabelle finden Sie im letzten Abschnitt der Collection („Open to see Sizes“).

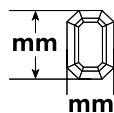

mm

Metrische Angaben in Millimetern.

FARBEN & EFFEKTE

Klassische Farben & Effekte

Das Klassik-Sortiment bietet eine umfassende Auswahl an Kristall-Basisfarben. Die Palette enthält alle klassischen Schmuckfarbtöne und macht nuancenreiche Kombinationen in verschiedenen Farbfamilien möglich.

Exklusive Farben & Effekte

Das Exklusiv-Sortiment enthält Kristallfarben, die aktuell und trendrelevant sind und exklusiv von Swarovski lanciert werden. Jeder Farbton wird in Zusammenarbeit mit internationalen Trendagenturen abgestimmt und setzt unverwechselbare Qualitätssignale. Exklusive Farben und Effekte sind in der jeweiligen Produktmatrix unterstrichen.

Die Farben und Effekte können je nach verschiedenen Lichtquellen unterschiedlich erscheinen. Farbfestlegung und -vergleich erfolgen bei Swarovski unter der Standard-Prüflichtquelle D50.

Spezielle Farbkarten zu einzelnen Produktgruppen befinden sich jeweils am Anfang jedes Kapitels.

Die einzelnen Farb- und Effektkategorien

In jeder Produktmatrix werden die Farben und Effekte nach folgenden Kategorien unterschieden:

Crystal
Crystal (001), simuliert oder unsimuliert
Colors
Plain Colors
Erhältliche Grundfarben
Opal Colors
Erhältliche Opalfarben
Crystal Blend Colors
Erhältliche Crystal Blendfarben
Ceramics
Erhältliche Keramikfarben
Colors
Colors
Erhältliche Grundfarben
Gemcolors
Erhältliche Edelsteinfarben
Neoncolors
Erhältliche Neonfarben
Crystal Effects or Color Effects
Transparent Effects
Erhältliche Transparenzeffekte
Metallic Effects
Erhältliche Effekte im Metallic-Look
Full Coating
Erhältliche Effekte mit Vollbeschichtung
Crystal Patina
Erhältliche Crystal Patina Effekte

Kristall

Kristallperlen

MOL	Moonlight
NUT	Nut (nur auf Jet)
REDM	Red Magma
ROGL	Rose Gold
SAT	Satin
SSHA	Silver Shade
TRA	Transmission

Durchscheineffekte

(Bedampfung der Rückseite, Effekt scheint durch transparenten Kristall durch)



Effektcode	Name
BBL	Bermuda Blue
HEL	Heliotrope
MBL	Meridian Blue
SINI	Silver Night
TAB	Tabac
VL	Vitrail Light
VM	Vitrail Medium
VOL	Volcano

Patina Effekte

Effektcode	Name
BLAPA	Black Patina
GOLPA	Gold Patina
ROSPA	Rose Patina
SILPA	Silver Patina
WHIPA	White Patina

Besondere Bedampfungsvarianten



2x
Beide Seiten des Kristalls werden bedampft (z. B. AB 2).



B
Speziell bei Würfelformen, Bedampfung von 3 Flächen (z. B. AB B).



V
Der Effekt wird umgekehrt angebracht. Der Oberflächeneffekt wird wie ein Durchscheineffekt verwendet (z. B. SSHA V – Silver Shade auf der Rückseite).



Z
Nur ein Teil des Kristalls wird bedampft (z. B. HEL Z).

FC (Full Coated – Vollbeschichtung)

Die optimierte Technologie sorgt rundum für einen gleichmäßigen, hochintensiven Metallic-Effekt im Beadsortiment (Art. 5000).

CAL 'V' SI & CAL 'VZ' SI

Bei besonderen Anforderungen (z. B. Knobs, Handles & Co.) wird der CAL (Comet Argent Light) Effekt anstatt der Standard-Similisierung (A, F...) als Silberspiegel auf der Rückseite des Kristalls verwendet.

/G

Artikel mit einer teilmatierten (PF) oder vollmatierten (FF) Oberfläche (z. B. Art. 2611/G)

PA (Patina)

Die innovative Technik sorgt für eine Teilbeschichtung der entsprechend adaptierten Effekte. Der historisch wirkende Vintage-Look verleiht der Kreation zeitlose Eleganz mit kristallinem Glanz.

EFFEKTE

Durch die Bedampfung der Kristalloberfläche entstehen je nach Bedampfungsart spezielle Oberflächen- oder Durchscheineffekte. Im Folgenden finden Sie eine Auflistung aller Swarovski Effekte, gefolgt von einer Erklärung zu besonderen Bedampfungsvarianten.

Oberflächeneffekte

(Bedampfung der Ansichtseite des Kristalls)



Effektcode	Name
AB	Aurore Boreale
ANTP	Antique Pink
API	Astral Pink
BLSH	Blue Shade
BRSH	Bronze Shade
CAL	Comet Argent Light
COP	Copper
DOR	Dorado
GSHA	Golden Shadow
HEM	Hematite (nur auf Jet)
IRIG	Iridescent Green
LISH	Lilac Shadow
LUMG	Luminous Green
METBL	Metallic Blue
MLGLD	Metallic Light Gold

Spezielle Oberflächeneffekte

Durch besondere chemische und mechanische Bearbeitung der Kristalloberfläche kann Swarovski spezielle Oberflächeneffekte erreichen.



MAT



COS

Effektcode	Name
MAT	Matt Finish
COS	Cosmojet

Der Effekt Matt Finish entsteht durch chemische Mattierung der gesamten Kristalloberfläche. Durch die chemische Behandlung des Kristalls können kleinere Maßabweichungen nach der Mattierung nicht ausgeschlossen werden.

Durch ein spezielles Verfahren können die Randfacetten bei Flat Back Rosen geschwärzt werden. Der Effekt Cosmojet ist nur bei der Farbe Crystal (001) möglich.

SIMILISIERUNG

Similisierung ist die brillanzverstärkende Verspiegelung der Rückseite von Schmucksteinen.



Silber-Foiling (A)

Ein Silberspiegel, nur für XILION & XIRIUS Hotfix Artikel



Platinum Pro Foiling (F)

Ein Silberspiegel, überzogen mit einer neu entwickelten platinfarbenen Schutzschicht von höchster Qualität. Das äußerst strapazierfähige Platinum Pro Foiling ist resistent gegen Umwelteinflüsse wie Chlor, Salzwasser, Parfüm und hält auch Verarbeitungsverfahren wie Löt- und Galvanisierprozessen problemlos stand.



Aluminium-Foiling (M)

Ein Aluminiumspiegel, vom technischen Standpunkt eine Bedampfung



Protective Layer (P) für Beads und Pendants

Bei Protective Layer handelt es sich um eine transparente Lackschicht, die auf Effekten aufgetragen wird. Diese Lackschicht wurde entwickelt, um die Effekte vor Kratzern, Fingerabdrücken und anderen Schäden zu schützen. Zudem beugt sie Feuchtigkeit (z. B. hervorgerufen durch Transpiration) vor, die zu Korrosion führen und in die Effektschicht eindringen kann, wenn Kristalle ohne Casings/Settings für Schmuckstücke verwendet werden.



Unsimilisiert (U)

HOTFIX TECHNOLOGIE

Hotfix (HF)

Bei der Hotfix-Technologie wird ein speziell entwickelter Klebstoff auf der Rückseite der Flat Backs angebracht. Der extrem flexible Kleber wird bei einer Temperatur von 120°C aktiviert und verbindet sich mit dem Trägermaterial. Durch seine hohe Flexibilität kann die Applikationstemperatur auf bis zu 170°C erhöht werden. Durch das Abkühlen werden die Kristallelemente dauerhaft auf dem Trägermaterial fixiert.

Hotfix Transparent (HFT)

Diese Hotfix-Variante mit einem patentierten, transparenten Haftvermittler, der auf unverspiegelten Flat Backs angebracht wird, bewirkt einen interessanten Regentropfen-Effekt, indem der Kristall die Farbe des Trägermaterials annimmt.

No Hotfix (No HF)

Hotfix-Produkte können wahlweise auch als No Hotfix Version ohne Kleber bestellt werden. Für nähere Informationen kontaktieren Sie bitte Ihre lokale Swarovski Vertriebsgesellschaft.

KUNDENINDIVIDUELLE PRODUKTLÖSUNGEN

Neben dem in der Collection angeführten Standardprogramm bieten wir die Möglichkeit von kundenindividuellen Produktlösungen.*

Folgende Möglichkeiten für kundenindividuelle Produktlösungen bestehen:

- **Standardartikel mit Nichtstandard-Farben und -Effekten**
- **Standardartikel mit Motiven/Prints**
- **Nichtstandard-Schliffe und -Größen**
- **Kundenspezifische Produktentwicklung**
- **Sonderlösungen von vorwärtsintegrierten Produkten**

Standardartikel sind in einzelnen Packungen erhältlich, kundenindividuelle Produktlösungen können jedoch aus technischen Gründen mit einer Mindestbestellmenge verbunden sein. 10 % Über- bzw. Unterlieferung ist möglich. Unterschreitet der Bestellwert der einzelnen Auftragsposition einen gewissen Mindestwert bei Standardartikeln in Nichtstandard-Farben und -Effekten (Details dazu finden Sie in der Swarovski Preisliste), wird ein Sonderproduktionszuschlag von 20 % berechnet. Bei kundenindividuellen Produktlösungen ist zudem mit einer individuellen Lieferzeit zu rechnen.

Für nähere Informationen und Beratung zu kundenindividuellen Produktlösungen kontaktieren Sie bitte Ihre lokale Swarovski Vertriebsgesellschaft.

* Kundenindividuelle Produktlösungen sind für alle Kunden erhältlich. Ihre Verfügbarkeit richtet sich jedoch nach den technischen Gegebenheiten sowie den Allgemeinen Geschäftsbedingungen.

GESETZE, BESTIMMUNGEN, NORMEN UND INDUSTRIESTANDARDS

Gemäß dem Advanced Crystal Standard erfüllt die Zusammensetzung von losem Kristall und vorwärtsintegrierten Produkten die Industriennormen und Gesetze, welche die Verwendung bestimmter Stoffe in den Fertigprodukten aus den wichtigsten Kundenbereichen einschränken oder verbieten, darunter auch:

Allgemeine Richtlinien und Gesetze

- Bleigehalt in Oberflächenbeschichtungen gemäß 16 CFR 1303

Schmuckrichtlinien

- Europäische Migrationsgrenzwerte für Nickel in Schmuck gemäß der REACH Verordnung 1907/2006/EG
- Europäische Cadmiumgrenzwerte in Schmuck gemäß der REACH Verordnung 1907/2006/EG
- Chinesischer Industriestandard QB/T 2997-2008 für Schmuck mit Edelmetallbeschichtungen
- Bleigrenzwerte in Schmuck und Oberflächenbeschichtungen gemäß dem US-kalifornischen Gesetz S.B. 646, in der Neufassung des US-kalifornischen Gesetzes zur Gesundheit und Sicherheit 25214.1 ff. (bekannt als kalifornisches Schmuckgesetz)
- Chinesischer Industrie Standard GB 28480-2012 betreffend der Limitierung schädlicher Substanzen im Schmuck

Richtlinien für Kinderartikel (3-14 Jahre)

- Bleigrenzwerte gemäß 16 CFR 1500 (US-amerikanisches Gesetz zur Verbesserung der Sicherheit von Verbraucherprodukten, CPSIA), US-amerikanisches Gesetz 74 43031
- Richtlinie 2009/48/EG über die Sicherheit von Spielzeug, Anhang II, Teil III.13 – Migrationsgrenzwerte für Schwermetalle
- ASTM F963-11, Sicherheit von Spielzeug, Paragraph 4.3.5.2., Migrationsgrenzwerte für Schwermetalle
- ASTM F2923-11 Standardnormen für die Produktsicherheit von Kinderschmuck
- Migrationsgrenzwerte für Cadmium gemäß dem Gesetz des US-Bundesstaates Illinois 430 ILCS 140, in der Neufassung von H.B. 5040 – Gesetz zur Cadmiumsicherheit in Kinderschmuck
- Migrationswerte für Cadmium gemäß dem Gesetz des US-Bundesstaates Minnesota 325E.3891 – Cadmium in Kinderschmuck
- California S.B. 929, in der Neufassung des US-kalifornischen Gesetzes zur Gesundheit und Sicherheit 25241.1 ff*
- Gesetz des US-Bundesstaates Connecticut 21a Paragraph 21a-12d – Cadmium in Kinderartikeln*
- Gesetz des US-Bundesstaates Maryland 6-1402 – Cadmium in Kinderschmuck*
- Koreanischer Qualitäts- und Kontrollstandard für Industrieprodukte*

Elektro- und Elektronikgeräte

Grenzwerte für den Schwermetallgehalt gemäß der europäischen Richtlinie 2011/65/EC (RoHS)*, dem koreanischen Gesetz für die Wiederverwendung von Rohstoffen aus Elektro-/Elektronikgeräten und Kfz* sowie dem japanischen Industriestandard (JIS)*

Verpackung

Grenzwerte für den Schwermetallgehalt gemäß der europäischen Verpackungsrichtlinie 94/62/EG* sowie die Richtlinien für Giftstoffe in Verpackungen (TPCH), die in bestimmten US-Bundesstaaten verabschiedet wurden*

Textilien

Kristall von Swarovski ist – mit nur wenigen Ausnahmen – nach Produktklasse II (Textilien mit Hautkontakt) des Öko-Tex-Standard 100, einem internationalen Gütesiegel für gesundheitlich unbedenkliche Textilien, zertifiziert. Weitere Einzelheiten über Kristall von Swarovski, das den Öko-Tex Standard 100 erfüllt, finden Sie unter WWW.SWAROVSKI.COM/PROFESSIONAL

* Hinweis: Die folgenden Kristallfarben erfüllen die o. a. Richtlinien nicht: Citrine, Fireopal, Hyacinth, Light Siam, Palace Green Opal, Siam und Sun.

Die o. a. Angaben gelten für aktuelle Rechtsvorschriften (Stand: März 2014). Dabei ist jedoch zu beachten, dass länderspezifisch unterschiedliche Gesetze und Richtlinien gelten, die in Zukunft Änderungen unterliegen können. Die Einhaltung aller Richtlinien kann daher nicht garantiert werden. Aktuelle Informationen finden Sie auf unserer B2B Website. Letztendlich liegt die Verantwortung für die Einhaltung der Gesetze und Richtlinien für die Fertigprodukte Dritter beim Hersteller der Fertigprodukte.

WARNHINWEISE



Allgemeiner Warnhinweis

Loose Kristalle können eine Kleinteilgefahr für kleine Kinder, insbesondere Kinder unter 3 Jahren, darstellen. Abhängig von der Größe der Kristalle und den beigefügten Materialien (wie z. B. Kleber, Textilien etc.) können Kinder daran ersticken, sie einatmen, verschlucken oder in die Nase einführen. Magnetprodukte mit Kristallapplikationen können bei Aufnahme in den Körper ein besonderes Risiko von ernsthaften Darmverletzungen darstellen. Die im Applikationshandbuch angeführten Applikationstechniken garantieren nicht, dass sich Kristalle nach der Applikation nicht ablösen. Der Hersteller muss für jede Applikation bestimmen, ob das Produkt die relevanten Bestimmungen hinsichtlich Kleinteilgefahren erfüllt, und muss jegliches Risiko, das es für Kinder darstellen kann, beurteilen. Das Nichtbeachten der von Swarovski erstellten Gebrauchsanweisung kann zu Schäden an den Kristallen führen, von denen Verletzungsrisiken oder andere Schäden ausgehen können.

Warnung für Crystal Tattoos

Crystal Tattoos dürfen nur auf gesunde Haut appliziert werden. Nicht in Augen oder auf Schleimhäute kleben. Crystal Tattoos sind für die Anwendung bei Kindern nicht empfehlenswert. Loose Kristalle können eine Kleinteilgefahr für kleine Kinder, insbesondere Kinder unter 3 Jahren, darstellen. Wenn sich ein Kristall löst, können sich Kinder, abhängig von der Größe der Kristalle daran verschlucken, sie inhalieren, schlucken oder in die Nase einführen.

Warnung für Geschirr

Das Anbringen von losen Kristallen an Geschirr birgt das potentielle Risiko von Aspiration, Ersticken, Schlucken oder Zahnschäden, sollten sich Kristalle lösen. Um dieses Risiko zu verringern, sollten die Kristalle weder an Oberflächen angebracht werden, die üblicherweise mit Lebensmittel oder Mund in Kontakt kommen, noch auf Geschirr, das für die Nutzungen durch Kinder bestimmt ist. Mit Kristallen versehenes Geschirr, das ausschließlich für dekorative Zwecke vorgesehen ist, sollte als solches entsprechend gekennzeichnet werden. Um Schäden durch den Geschirrspüler zu vermeiden sollte mit Kristallen verziertes Geschirr von Hand gewaschen werden. Die Applikationstechniken oder Empfehlungen im Application Manual garantieren nicht, dass sich Kristalle nach der Applikation nicht ablösen. Der Hersteller muss für jede Applikation bestimmen, ob das Produkt die relevanten Bestimmungen hinsichtlich Kleinteilgefahren oder hinsichtlich dem Gebrauch von Materialien, welche üblicherweise mit Lebensmittel in Kontakt kommen, erfüllt, und muss jegliches Risiko, das es für den Nutzer darstellen kann, beurteilen.

Die Verwendung von Kristallen, (welche Substanzen enthalten können, die in den jeweiligen nationalen Gesetzen als gefährlich bekannt sind), sowie Klebstoffe auf Geschirr, unterliegen in bestimmten Ländern gesetzlichen Einschränkungen. Für die Einhaltung dieser länderspezifischen Vorschriften ist der Kunde verantwortlich und stellt Swarovski für alle im Bereich der Produkthaftung in diesem Zusammenhang geltend gemachten Ansprüche von Dritten vollkommen frei und verzichtet auf die Geltendmachung eigener Ansprüche.

Ungeeignete Applikationen

Kristall von Swarovski wird typischerweise im Bereich der Mode zu Schmuck, Accessoires, auf textilen Produkten und im Bereich Interieur verarbeitet. Aufgrund seiner physikalischen Eigenschaften ist Kristall von Swarovski für sonstige Applikationen ungeeignet (z. B. Aufkleben auf Zähnen, die Verwendung von Kristallen auf und in der Nähe von Schleimhäuten und andere untypische Anwendungen). Für alle im Bereich der Produkthaftung in diesem Zusammenhang geltend gemachten Ansprüche von Dritten stellt der Kunde Swarovski vollkommen frei und verzichtet auf die Geltendmachung eigener Ansprüche.

Verantwortung des Anwenders

Unsere anwendungstechnische Beratung in Wort, Bild und durch Versuche erfolgt nach dem heutigen Stand unserer Kenntnisse und den Angaben unserer Lieferanten. Sie kann jedoch die eigene Prüfung des Kunden der von uns vorgeschlagenen Verfahren auf deren Eignung für die beabsichtigte Anwendung nicht ersetzen. Anwendung, Verwendung und Verarbeitung der Verfahren und Produkte erfolgen daher ausschließlich im Verantwortungsbereich des Anwenders.

COLLECTIONS

Swarovski est le premier fabricant mondial de cristal taillé utilisé dans les industries de la mode et de la bijouterie, ainsi que dans les univers de l'éclairage, de l'architecture et de la décoration d'intérieur. Les cristaux Swarovski sont devenus un des éléments indissociables de l'univers créatif international. La société commercialise ses pierres en vrac et ses produits semi-finis à travers le monde sous la marque produit Swarovski.

Cette Collection présente la gamme complète des composants au programme. Ces informations produits sont également téléchargeables au format numérique sur le site Internet WWW.SWAROVSKI.COM/PROFESSIONAL, et sur la nouvelle application Collection pour iPad disponible sur iTunes en avril 2014. Les fondements de l'entreprise, depuis sa création en 1895, sont perfection et innovation. À cette constante quête de l'excellence s'associe une implication assidue dans l'étude des tendances et dans la recherche et le développement de nouvelles pierres – couleurs ou effets qui complètent la gamme deux fois par an avec les collections Printemps/Été et Automne/Hiver. Ces nouveautés sont lancées chaque année en février et en septembre, et sont complétées d'un lancement de mi-saison en mai.

Afin de conserver son titre de leader mondial du cristal taillé, Swarovski propose également des collections de composants dédiés à certaines industries spécifiques ainsi qu'un service de solutions personnalisées, et un service de support en tendances et en applications. Pour obtenir de plus amples informations concernant les produits Swarovski, les services et outils de communication, nous vous recommandons de contacter votre bureau de vente Swarovski.

COMMANDER

Merci de contacter votre bureau de vente Swarovski pour toute commande. Nous proposons également, à travers le site WWW.B2B.ECOMMERCE.SWAROVSKI.COM, un service de commandes en ligne à tous les clients enregistrés. Ce site contient également des informations importantes concernant les produits, leur disponibilité, les détails de livraison. Nous vous recommandons de contacter votre bureau de vente Swarovski pour vous inscrire à ce service.

SERVICE APPLICATIONS

Grâce à leur perfection et aux différentes techniques d'application spécialement mises au point, les cristaux Swarovski peuvent être appliqués facilement et rapidement tout en privilégiant un fini hautement qualitatif.

Le manuel d'application contient des informations détaillées sur l'ensemble des techniques d'application existantes et les services techniques proposés par Swarovski. Par le biais d'illustrations et d'instructions détaillées, il explique comment souder, plaquer, coller, travailler Ceralun™, coudre, broder, thermocoller les Hotfix, et appliquer mécaniquement les cristaux, et propose également des consignes d'entretien et des informations utiles sur les machines, les outillages et le matériel nécessaires avec les coordonnées des principaux fournisseurs. Le manuel est disponible en différentes langues internationales.

L'ensemble des informations détaillées et actualisées concernant le manuel d'application est également disponible sur le site Internet WWW.SWAROVSKI.COM/PROFESSIONAL. Les techniques d'application y sont également expliquées sous

forme d'animations et de vidéos. Veuillez contacter votre bureau de vente local Swarovski pour obtenir vos codes d'accès à la section interne du site Internet dédié aux professionnels. Pour toutes questions spécifiques concernant les techniques d'application, veuillez contacter votre bureau de vente Swarovski.

PRODUITS PARTIELLEMENT OU NON TAILLÉS

La collection standard comprend des produits taillés et également des produits partiellement ou non taillés.

/3

Le cristal n'a pas été taillé mais comporte des facettes moulées.



/4

Le cristal n'a pas été taillé et n'a pas de facette (ex : art. 2080/4).

DIMENSIONS

Différentes abréviations sont utilisées pour classer les pierres de bijouterie selon leur dimension.



PP, SS

Pearl Plate (PP), Sieve Size ou Stone Size (SS) pour les pierres en cristal rondes. Veuillez également vous référer au tableau des dimensions, disponible à la fin du catalogue Collection (« Open to See Sizes »).

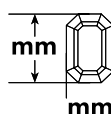

mm

Mesure métrique en millimètres.

COULEURS ET EFFETS

Couleurs et effets classiques

La gamme de couleurs classiques comprend toutes les couleurs classiques de la bijouterie. Les couleurs existantes permettent d'obtenir des combinaisons originales et riches en nuances.

Couleurs et effets exclusifs

La gamme exclusive offre des coloris en accord avec les dernières tendances et qui sont exclusivement lancés par Swarovski. Chaque couleur, développée en coopération avec des bureaux de tendance internationaux, porte le sceau inimitable de la qualité et de la créativité Swarovski. Les couleurs et effets exclusifs sont reconnaissables dans chaque gamme de produit car leur nom est souligné.

Les couleurs et les effets peuvent varier selon les sources de lumières utilisées. Swarovski utilise l'éclairage standard D50 pour définir les couleurs et les comparer. Les nuanciers spécifiques de certains groupes de produits sont disponibles au début de leur rubrique respective.

Catégories de couleurs et d'effets

Les couleurs et les effets sont organisés spécifiquement dans chaque gamme de produit:

Crystal
Crystal (001), simulisé ou non simulisé
Couleurs
Couleurs unies
Couleurs unies existantes
Couleurs Opal
Couleurs Opal existantes
Couleurs Crystal Blend
Couleurs Crystal Blend existantes
Ceramics
Couleurs Ceramics existantes
Couleurs
Couleurs
Couleurs unies existantes
Gemcolors
Gemcolors existantes
Neoncolors
Neoncolors existantes
Crystal Effects ou Color Effects
Effets transparents
Effets transparents existants
Effets métallisés
Effets métallisés existants
Revêtement intégral
Effets revêtement intégral existants
Crystal Patina
Effets Crystal Patina existants

Pour les composants en cristal

Pour les Crystal Pearls

MOL	Moonlight
NUT	Nut (uniquement sur Jet)
REDM	Red Magma
ROGL	Rose Gold
SAT	Satin
SSHA	Silver Shade
TRA	Transmission

Effets translucides

(Revêtement par vaporisation au dos du cristal, l'effet brille par transparence à travers le cristal)



Code d'effet	Nom
BBL	Bermuda Blue
HEL	Heliotrope
MBL	Meridian Blue
SINI	Silver Night
TAB	Tabac
VL	Vitrail Light
VM	Vitrail Medium
VOL	Volcano

Effets de patine

Code d'effet	Nom
BLAPA	Black Patina
GOLPA	Gold Patina
ROSPA	Rose Patina
SILPA	Silver Patina
WHIPA	White Patina

Variantes des effets de surface



2x
Les deux faces de la pierre sont traitées avec un effet (ex. : AB 2).



B
Effets sur trois côtés d'une forme cubique (ex. : AB B).



V
L'effet est appliqué sur l'envers. L'effet de surface est visible par transparence (ex. : SSHA V - Silver Shade sur l'envers).



Z
Seule une partie de la pierre est traitée avec un effet (ex. : HEL Z).

EFFETS

Les procédés de revêtement par vaporisation produisent un effet de surface spécial ou translucide en fonction des méthodes utilisées. Vous trouverez ci-dessous une liste de tous les effets Swarovski ainsi que le détail des méthodes de revêtement par vaporisation.

Effets de surface

(Revêtement par vaporisation sur la surface du cristal)



Code d'effet	Nom
AB	Aurore Boreale
ANTP	Antique Pink
API	Astral Pink
BLSH	Blue Shade
BRSH	Bronze Shade
CAL	Comet Argent Light
COP	Copper
DOR	Dorado
GSHA	Golden Shadow
HEM	Hematite (uniquement sur Jet)
IRIG	Iridescent Green
LISH	Lilac Shadow
LUMG	Luminous Green
METBL	Metallic Blue
MLGLD	Metallic Light Gold

FC (Full Coating - Revêtement intégral)

Cette technique avancée permet une application intégrale et parfaitement homogène d'effets métallisés de haute intensité dans la gamme des Beads (art. 5000).

CAL 'V' SI & CAL 'VZ' SI

L'effet CAL (Comet Argent Light) est aussi utilisé comme revêtement miroir au dos du composant cristal en remplacement des simulisations standard (A, F, ...) pour des produits spécifiques (par ex. Knobs, Handles & Co.).

/G

Produit dont la surface est partiellement (PF) ou entièrement (full) dépolie (FF) (par ex. art. 2611/G)

PA (Patine)

Cette technique innovante permet un revêtement partiel d'effets adaptés. Le lustre patiné et le rendu « usé » lui confèrent un charme intemporel sans perdre l'aspect cristallin.

Effets de surface spéciaux

Swarovski est capable de produire différents effets de surface grâce à des procédés chimiques et mécaniques spécifiques appliqués sur la surface des cristaux.



MAT



COS

Code d'effet	Nom
MAT	Matt Finish
COS	Cosmojet

L'effet Matt Finish résulte d'un traitement chimique matifiant appliqué sur toute la surface du cristal, qui peut entraîner de légères variations dans la dimension des articles. Les facettes externes des Flat Back Roses peuvent être noircies grâce à une technique particulière. L'effet Cosmojet n'est disponible que pour la couleur Crystal (001).

SIMILISATION

La similitude est un procédé de revêtement miroir appliqué au dos des composants.

**Similisation Argent (A)**

Revêtement miroir en Argent existant uniquement pour les articles de la gamme XIRIUS et XILLION Hotfix.

**Similisation Pro Platiniium (F)**

Revêtement miroir argenté recouvert d'une couche protectrice haut de gamme de couleur platine. La similitude Pro Platiniium résiste aux agressions environnementales dues au chlore, à l'eau salée ou au parfum, et peut également supporter des procédés tels que la soudure et la galvanisation et offrir ainsi une durabilité exceptionnelle.

**Similisation Aluminium (M)**

Revêtement miroir aluminium appliqué par vaporisation.

**Vernis protecteur (P) pour les Beads et Pendants**

Le vernis protecteur est une couche de laque transparente appliquée sur les effets. Ce vernis protège les effets des rayures, traces de doigt et autres agressions. Il protège également la qualité des effets des composants en cristal non sertis utilisés dans la bijouterie qui pourraient être exposés à l'humidité et à la corrosion (ex. la transpiration).

**Non simulée (U)****TECHNOLOGIE HOTFIX****Hotfix (HF)**

La technologie Hotfix désigne le thermocollage d'un composant à fond plat Flat Back dont la partie simulée est préalablement revêtue d'un adhésif spécifique. Cet adhésif spécialement développé, entre en action à une température de 120°C, avec une souplesse d'application pouvant aller jusqu'à 170°C, et adhère au support de base. Le composant en cristal est définitivement fixé au support lors du refroidissement de l'adhésif.

Hotfix Transparent (HFT)

Cette variante de la technologie Hotfix désigne le thermocollage d'un composant en cristal à fond plat Flat Back non simulé dont l'arrière est préalablement revêtu d'un adhésif spécifique et breveté, totalement transparent, qui donne un effet goutte d'eau et qui permet au cristal d'emprunter les couleurs du support de base sur lequel il aura été thermocollé.

No Hotfix (No HF)

Les produits Hotfix sont également disponibles en version Non Hotfix, c'est-à-dire sans adhésif Hotfix pré appliqué au dos de la pierre. Pour plus d'informations, veuillez contacter votre service client.

SOLUTIONS PERSONNALISÉES

Swarovski propose des solutions personnalisées en complément de la collection standard*.

Les solutions personnalisées suivantes sont proposées:

- **Produits standards dans des couleurs ou des effets non standards**
- **Produits standards avec gravures/impressions de motifs**
- **Facettages et dimensions spécifiques**
- **Développement de produits personnalisés**
- **Produits semi-finis personnalisés**

Pour des raisons techniques, les produits personnalisés sont soumis à des minima de commande, alors que les produits standards sont proposés au paquet. La quantité des produits personnalisés peut parfois varier de plus ou moins 10% à la livraison. Si le montant de commande d'un produit personnalisé avec des couleurs ou des effets non existants dans la gamme s'avère inférieure au minimum fixé pour un produit en collection standard (se référer à la liste des prix de Swarovski pour plus de détails), une majoration supplémentaire de 20% sera appliquée.

Veuillez noter que les solutions personnalisées impliquent des délais de livraison spécifiques.

Pour plus d'informations et de conseils concernant les solutions personnalisées, veuillez contacter votre service client.

* Les solutions personnalisées sont disponibles pour tous les clients, sous réserve de leur faisabilité technique et du respect de nos conditions générales de vente.

LOIS, RÉGLEMENTATIONS, NORMES ET STANDARDS

La composition des composants en cristal et produits semi-finis Advanced Crystal standard est conforme avec les normes industrielles réglementaires en vigueur dans les différents secteurs d'activités de la plus grande majorité de nos clients. Ces normes régissent la restriction ou l'interdiction d'utiliser certaines substances dans la production de leurs propres produits finis et font référence :

En général

- Au taux de plomb dans les revêtements de surface comme indiqué dans la norme 16 CFR 1303

Normes en vigueur dans la bijouterie

- Aux restrictions européennes limitant la libération de nickel dans les bijoux comme spécifié dans la réglementation REACH 1907/2006/EG
- Aux restrictions européennes limitant la teneur en cadmium dans les bijoux comme spécifié dans la réglementation REACH 1907/2006/EG
- Aux standards Industriels en Chine QB/T 2997-2008 sur les ornements avec revêtements en métal précieux
- Aux restrictions limitant la teneur en plomb dans la bijouterie et les revêtements de surface comme spécifié dans la réglementation California S.B. 646, révisant le Code de santé de Californie, section 25214.1. (plus connue sous le nom de California Jewelry Law)
- Aux restrictions limitant la teneur en éléments nocifs dans les ornements en Chine GB 28480-2012

Normes en vigueur pour les produits pour enfants (de 3 à 14 ans)

- Aux restrictions limitant la teneur en plomb comme spécifié dans l'article 16 CFR 1500 (U.S. Consumer Product Safety Improvement Act, CPSIA), U.S. 74 Fed. Reg. 43031
- Aux restrictions limitant la migration des métaux lourds comme spécifié dans la Directive 2009/48/EU, sur la Sécurité des jouets, annexe II, section III.13
- Aux restrictions limitant la migration des métaux lourds comme spécifié dans la Directive ASTM F963-11, sur la Sécurité des jouets, section 4.3.5.2.
- Aux spécifications standards de la Directive ASTM F2923-11 relative à la sécurité des produits de consommation et plus spécifiquement aux bijoux pour enfants
- Aux restrictions limitant la migration du cadmium comme spécifié dans la Loi sur la sécurité des enfants en vigueur dans l'Illinois 430 ILCS 140, révisée par l'article H.B. 5040
- Aux restrictions limitant la migration du cadmium comme spécifié dans les lois en vigueur au Minnesota 325E.3891 – Cadmium dans les bijoux pour enfants
- À la Réglementation California S.B. 929, révisant le Code de santé de Californie, section 25241.1*
- Aux Statuts généraux du Connecticut 21a Sec 21a-12d – Cadmium dans les produits pour enfants*
- Au Code du Maryland 6-1402 – Cadmium dans les bijoux pour enfants*
- À la réglementation coréenne Korean Quality Management and Safety Control of Industrial Products Act*

Normes en vigueur pour les produits électriques et électroniques

Aux restrictions limitant le taux de métaux lourds comme spécifié dans la directive européenne RoHS (2011/65/EC)*, la loi coréenne Korean Act for Resource Recycling of Electrical/Electronic Products and Automobiles*, et la loi japonaise Japanese Industrial Standard*

Normes en vigueur dans l'industrie du packaging

Aux restrictions limitant le taux de métaux lourds dans la directive européenne 94/62/EC*, et la réglementation Toxics in Packaging Clearinghouse (TPCH) en vigueur dans certains états des États-Unis*

Normes en vigueur dans les produits textiles

Les cristaux Swarovski, à quelques rares exceptions, sont certifiés Oeko-Tex Standard 100 Class II (pour les produits en contact avec la peau), un label qualité international qualifiant les textiles inoffensifs. Pour connaître la liste des cristaux Swarovski conformes à la certification Oeko-Tex® Standard 100, visitez notre site Internet WWW.SWAROVSKI.COM/PROFESSIONAL

* Veuillez noter que les coloris suivants ne sont pas conformes aux normes citées : Citrine, Fireopal, Hyacinth, Light Siam, Palace Green Opal, Siam et Sun.

Note : Ces informations concernent les réglementations en vigueur (à partir de mars 2014). Les différentes lois et réglementations peuvent être modifiées sans préavis et varier d'un pays à un autre, nous ne pouvons pas garantir de répondre à toutes les obligations des réglementations. Pour plus d'informations, veuillez consulter notre site Internet dédié aux professionnels. La responsabilité concernant la conformité des produits finis aux tiers incombe aux fabricants des produits finis.

MISES EN GARDE

Avertissement général



Les cristaux mobiles ou qui se détachent peuvent représenter un risque pour les jeunes enfants et plus particulièrement pour ceux de moins de trois ans. Les composants en cristal de petites dimensions ainsi que les matériaux associés (colle, tissu, etc.) sont à maintenir hors de portée des enfants afin d'éviter tout risque d'ingestion ou d'inhalation accidentelle entraînant l'étouffement. L'ingestion de produits magnétiques décorés avec du cristal peut engendrer un risque sérieux de lésions intestinales. Les techniques d'applications détaillées dans le manuel d'application ne garantissent pas qu'aucun cristal ne se détachera. Le fabricant devra déterminer si son produit fini satisfait, selon son usage, aux normes qui protègent des risques associés aux petites pièces et mesurera le danger que celui-ci pourrait représenter pour de jeunes enfants. Le non respect des consignes d'entretien recommandées par Swarovski risque d'endommager les composants en cristal qui pourraient par conséquent provoquer des lacérations ou d'autres dégâts.

Avertissement concernant les Crystal Tattoos

Les Crystal Tattoos doivent être exclusivement appliqués sur une peau saine. Ne pas appliquer sur les yeux ou les muqueuses. Les Crystal Tattoos ne sont pas recommandés pour de jeunes enfants. Les cristaux mobiles ou qui se détachent peuvent représenter un risque pour les jeunes enfants et plus particulièrement pour ceux de moins de trois ans. Les composants en cristal de petites dimensions qui se détacheraient sont à maintenir hors de portée des enfants afin d'éviter tout risque d'ingestion ou d'inhalation accidentelle entraînant l'étouffement.

Avertissement concernant la vaisselle usuelle

L'application de cristaux mobiles ou qui peuvent éventuellement se détacher sur de la vaisselle usuelle présente un risque potentiel d'inhalation ou d'ingestion accidentelle pouvant entraîner l'étouffement ou des dégâts dentaires éventuels. Afin de limiter ces risques, les cristaux ne doivent jamais être appliqués sur de la vaisselle usuelle susceptible d'entrer en contact avec des aliments ou la bouche, ni sur de la vaisselle usuelle destinée aux enfants. La vaisselle ornée de cristaux à usage exclusivement décoratif doit être spécifiée comme étant décorative uniquement. Il est conseillé de laver à la main la vaisselle décorative ornée de cristaux afin d'éviter d'endommager les cristaux au lave-vaisselle. Les techniques ou recommandations d'application détaillées dans le manuel d'application ne garantissent pas qu'aucun cristal ne se détachera. Le fabricant devra déterminer si son produit fini satisfait, selon son usage, aux normes qui protègent des risques associés aux petites pièces ainsi qu'à la réglementation des produits en contact avec les aliments et mesurera le danger que celui-ci peut représenter pour les usagers.

L'utilisation de cristaux (susceptibles de contenir des substances considérées comme dangereuses selon la législation locale propre à certains pays) et d'adhésifs sur de la vaisselle usuelle est soumise à des restrictions légales propres à certains pays. Le client assume l'entière responsabilité de conformité avec les dispositions spécifiques à chaque pays et défend, indemnise et garantit Swarovski contre les recours de tout tiers reposant sur la responsabilité des produits ou relevant de tout autre mode d'utilisation des produits acquis par le client, et renonce à ses propres réclamations.

Clause d'utilisation

Les cristaux Swarovski sont destinés aux industries de la mode, de la bijouterie, des accessoires, du textile et de la décoration d'intérieur. En raison de leurs propriétés physiques, les cristaux Swarovski ne sont pas adaptés à d'autres usages (ex : collage sur les dents, utilisation de cristaux sur ou proche de muqueuses ou autres utilisations dangereuses). Le client défend, indemnise et garantit Swarovski contre les recours de tout tiers reposant sur la responsabilité des produits ou relevant de tout autre mode d'utilisation des produits acquis par le client, et renonce à ses propres réclamations.

Responsabilité de l'utilisateur

Tout avis oral, écrit ou reposant sur des rapports de tests délivrés par Swarovski concernant les techniques d'application de ses produits constitue des recommandations basées sur les connaissances actuelles de Swarovski et les informations obtenues de ses fournisseurs. De tels avis ne déchargent pas le client de son obligation de procéder à ses propres tests techniques au regard de l'utilisation envisagée par ses soins aux fins d'en vérifier l'adéquation. L'application, l'utilisation et le traitement de ces produits et de ces techniques sont de la seule responsabilité du client.

COLLECTION

Swarovski è leader mondiale nella produzione di cristalli tagliati ad alta precisione e utilizzati per la realizzazione di prodotti di lusso in vari settori, quali moda, gioielleria e arredamento.

I cristalli Swarovski rappresentano in tutto il mondo una risorsa imprescindibile per la realizzazione di creazioni straordinarie.

La società commercializza cristalli sciolti e prodotti semifiniti per applicazioni su articoli di moda e design con il marchio Swarovski.

In questo Collection è illustrata l'intera gamma di prodotti. Informazioni complete su di essi sono inoltre disponibili, sul nostro sito web dedicato alle aziende: WWW.SWAROVSKI.COM/PROFESSIONAL, e tramite una nuova app Collection per iPad disponibile su iTunes a partire dall'aprile 2014. La totale dedizione alla perfezione e all'innovazione rappresentano il pilastro della politica aziendale fin dall'anno della fondazione, nel 1895. Questa ricerca dell'eccellenza sostiene l'impegno di Swarovski nello studio e nella creazione di nuove tendenze. Da questo impegno nascono le collezioni Primavera/Estate e Autunno/Inverno, che aggiungono, ogni sei mesi, nuovi effetti e colori alla gamma di elementi in cristallo Swarovski. Queste innovazioni stagionali vengono presentate a febbraio e a settembre, e in occasione di un lancio pre-stagionale nel mese di maggio.

Determinata a consolidare la sua posizione di leader mondiale nel settore del cristallo tagliato ad alta precisione, Swarovski offre ai suoi clienti collezioni realizzate per segmenti specifici e soluzioni personalizzate, nonché servizi di supporto dedicati alle tendenze di moda e all'applicazione dei cristalli. Per ulteriori informazioni su prodotti, servizi e materiali di vendita, vi invitiamo a contattare l'ufficio vendite Swarovski della vostra zona.

ORDINI

Per ordinare i prodotti, vi invitiamo a contattare il responsabile di zona Swarovski. I clienti registrati possono ordinare online utilizzando il pratico servizio di e-commerce disponibile all'indirizzo WWW.B2B.ECOMMERCE.SWAROVSKI.COM. Oltre a permettere di effettuare l'ordine online, il sito contiene importanti informazioni su prodotti, disponibilità e consegne. Per usufruire di questo servizio, i clienti possono registrarsi contattando il responsabile di zona Swarovski.

INFORMAZIONI SULLE TECNICHE DI APPLICAZIONE

Grazie alla loro straordinaria qualità e all'aiuto di tecniche di applicazione appositamente sviluppate, i cristalli Swarovski possono essere applicati in modo semplice e rapido, con una finitura di alto livello.

Il Manuale di Applicazione contiene informazioni approfondite su tutte le attuali tecniche di applicazione e sui servizi tecnici forniti da Swarovski. Contiene immagini e istruzioni dettagliate sulle corrette procedure di saldatura, elettrodeposizione, incollaggio, utilizzo del Ceralun™, cucitura, ricamo, applicazione a caldo (Hotfix) e applicazione meccanica, oltre a istruzioni utili per la cura degli articoli finiti e per l'uso di macchine, strumenti e accessori per l'applicazione corredate da informazioni sui relativi fornitori. Il manuale è disponibile in varie lingue.

Tutte le informazioni dettagliate e aggiornate relative al Manuale di Applicazione sono disponibili anche online sul sito web WWW.SWAROVSKI.COM/PROFESSIONAL.

Le tecniche d'applicazione sono altresì dimostrate tramite filmati e animazioni.

Per ottenere l'accesso alla sezione riservata del sito web dedicato alle aziende, vi invitiamo a contattare il responsabile di zona Swarovski.

Per informazioni specifiche sulle tecniche d'applicazione, vi invitiamo a contattare l'ufficio vendite Swarovski della vostra zona.

ARTICOLI NON MOLATI E PARZIALMENTE MOLATI

La collezione standard non comprende solo articoli molati, ma anche articoli non molati o solo parzialmente molati.

/3

Cristallo non molato e con faccette impresse.



/4

Cristallo non molato e senza faccette (es. art. 2080/4).

DIMENSIONI

Le dimensioni dei cristalli vengono indicate mediante abbreviazioni.

**PP, SS**

Sieve Size (SS) e Pearl Plate (PP) sono le unità di misura usate per i cristalli tondi. A questo riguardo, consultare la tabella di conversione riportata nell'ultima pagina del catalogo ("Open to See Sizes").

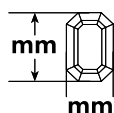
**mm**

Dimensioni espresse in millimetri.

COLORI ED EFFETTI**Colori ed effetti classici**

L'assortimento Classic comprende una vasta scelta di colori, incluse tutte le classiche tonalità delle pietre per gioielleria, per ottenere combinazioni splendide non solo perché originali, ma anche perché ricche di sfumature.

Colori ed effetti esclusivi

L'assortimento Exclusive comprende colori lanciati in esclusiva da Swarovski in linea con le ultime tendenze della moda. Ciascun colore, sviluppato in collaborazione con agenzie di moda internazionali, reca l'inconfondibile marchio di qualità e creatività Swarovski. Colori ed effetti esclusivi appaiono come nomi sottolineati nelle matrici dei prodotti.

Colori ed effetti possono apparire diversi se illuminati da fonti di luce diverse. Swarovski si serve di una fonte di luce standard D50 per la scelta e per i confronti di colore.

All'inizio di ogni sezione sono riportate le cartelle colori dedicate a ogni gruppo di prodotti.

Categorie di colori ed effetti

Nelle matrici dei prodotti, colori ed effetti seguono una segmentazione specifica:

Cristallo
Cristallo (001), con o senza foiling
Colori
Colori Plain
Colori Plain disponibili
Colori Opal
Colori Opal disponibili
Colori Crystal Blend
Colori Crystal Blend disponibili
Ceramics
Colori Ceramics disponibili
Colori
Colori
Colori Plain disponibili
Gemcolors
Gemcolors disponibili
Neoncolors
Neoncolors disponibili
Effetti dei cristalli o effetti dei colori
Effetti trasparenti
Effetti trasparenti disponibili
Effetti metallici
Effetti dal look metallico disponibili
Full Coating
Effetti Full Coating disponibili
Crystal Patina
Effetti Crystal Patina disponibili

Per cristalli

Per Crystal Pearls

MOL	Moonlight
NUT	Nut (solo su Jet)
REDM	Red Magma
ROGL	Rose Gold
SAT	Satin
SSHA	Silver Shade
TRA	Transmission

Effetti in trasparenza

(Processo di vaporizzazione applicato sul retro della pietra e visibile attraverso il cristallo trasparente)



Codice effetto	Nome
BBL	Bermuda Blue
HEL	Heliotrope
MBL	Meridian Blue
SINI	Silver Night
TAB	Tabac
VL	Vitrail Light
VM	Vitrail Medium
VOL	Volcano

Effetti Patina

Codice effetto	Nome
BLAPA	Black Patina
GOLPA	Gold Patina
ROSPA	Rose Patina
SILPA	Silver Patina
WHIPA	White Patina

Variazioni sugli effetti speciali in superficie



2x
L'effetto viene applicato su entrambe le facce della pietra (per esempio AB 2).



B
L'effetto viene applicato sui tre lati di un cubo (per esempio AB B).



V
L'effetto viene applicato sul rovescio. Viene utilizzato un effetto in superficie come un effetto in trasparenza (es. SSHA V - Silver Shade sul rovescio).



Z
L'effetto viene applicato solo su una parte della pietra (es. HEL Z).

FC (Full Coated)

Tecnologia ottimizzata che crea un'applicazione perfettamente omogenea e a tutto tondo di effetti metallici ad alta intensità nell'assortimento Bead (art. 5000).

CAL 'V 'SI e CAL 'VZ 'SI

L'effetto CAL (Comet Argent Light) viene altresì utilizzato come rivestimento specchiato sul lato posteriore del cristallo al posto del foiling standard (A, F, ...) in casi speciali (ad es. manopole, maniglie, ecc.).

/G

Articolo con superficie parzialmente (PF) o totalmente satinata (FF) (ad es. art. 2611/G)

PA (Patina)

Tecnologia innovativa che ricopre parzialmente il cristallo aggiungendo un tocco vintage all'effetto a cui si applica. Il suo look "vissuto" gli conferisce un carattere intramontabile senza comprometterne l'aspetto cristallino.

EFFETTI

La vaporizzazione sulla superficie del cristallo produce effetti speciali in superficie o in trasparenza, a seconda dei metodi applicativi impiegati. Di seguito riportiamo una lista di tutti gli effetti Swarovski corredati da una spiegazione degli speciali processi di vaporizzazione.

Effetti in superficie

(Processo di vaporizzazione applicato sulla superficie del cristallo)



Codice effetto	Nome
AB	Aurora Boreale
ANTP	Antique Pink
API	Astral Pink
BLSH	Blue Shade
BRSH	Bronze Shade
CAL	Comet Argent Light
COP	Copper
DOR	Dorado
GSHA	Golden Shadow
HEM	Hematite (solo su Jet)
IRIG	Iridescent Green
LISH	Lilac Shadow
LUMG	Luminous Green
METBL	Metallic Blue
MLGLD	Metallic Light Gold

Effetti speciali in superficie

Trattando la superficie dei cristalli con speciali processi chimici e meccanici, Swarovski è riuscita ad ottenere diversi effetti speciali in superficie.



MAT



COS

Codice effetto	Nome
MAT	Matt Finish
COS	Cosmojet

L'effetto Matt Finish si ottiene mediante un processo chimico di opacizzazione dell'intera superficie del cristallo. Questo processo può produrre piccole variazioni nelle dimensioni degli articoli. Un processo speciale permette di scurire le faccette esterne delle Flat Back Roses. L'effetto Cosmojet è possibile solamente per il colore Crystal (001).

TALCATURA O FOILING

Per talcatura (o foiling) si intende il processo di metallizzazione a specchio applicato sul rovescio dei cristalli.

**Silver Foiling (A)**

Finitura a specchio in argento solo per articoli XIRIUS e XILION Hotfix.

**Platinum Pro Foiling (F)**

Finitura a specchio in argento rivestito con uno strato protettivo color platino della migliore qualità. La finitura Platinum Pro Foiling non solo resiste ai danni ambientali causati da cloro, acqua salata e profumo, ma è altresì in grado di resistere a processi come saldatura ed elettrodeposizione, assicurando una durata impareggiabile.

**Aluminum Foiling (M)**

Finitura a specchio in alluminio applicata mediante un processo di vaporizzazione.

**Protective Layer (P) per bead e pendenti**

Il Protective Layer è un rivestimento in smalto trasparente applicato sopra gli effetti. Questo smalto è studiato in modo tale da proteggere la superficie da graffi, segni e impronte di dita. Inoltre impedisce che l'umidità penetri attraverso lo strato degli effetti provocandone la corrosione (ad es. tramite perspirazione) nel caso di gioielli decorati con cristalli privi di apposita sede/montatura.

**Senza Foiling (U)****TECNOLOGIA HOTFIX****Hotfix (HF)**

La tecnologia Hotfix prevede l'applicazione di una colla speciale sul retro dei cristalli Flat Back. Questa colla estremamente flessibile si attiva a una temperatura di 120°C e raggiunge la giusta flessibilità applicativa a 170°C legandosi al materiale di supporto. Una volta raffreddata, la colla fissa i componenti di cristallo in modo permanente.

Hotfix Transparent (HFT)

Questa variante della tecnologia Hotfix consiste nell'applicazione di un agente legante brevettato sul retro delle pietre Flat Back senza talcatura. Il risultato è un interessante "effetto goccia" che consente al cristallo di assumere il colore dei materiali di supporto.

No Hotfix (No HF)

Tutti gli articoli Hotfix sono disponibili anche nella versione No Hotfix, ovvero senza colla sul retro. Per ulteriori informazioni, vi invitiamo a contattare il Servizio Clienti della vostra zona.

SOLUZIONI PERSONALIZZATE

Oltre alla collezione standard, Swarovski offre un servizio per la realizzazione di soluzioni personalizzate*.

Possono essere offerte le seguenti soluzioni personalizzate:

- articoli standard con colori ed effetti personalizzati
- articoli standard con motivi/stampe
- tagli e dimensioni personalizzati
- sviluppo di prodotti personalizzati
- prodotti semifiniti personalizzati

Per ragioni tecniche, non è possibile richiedere soluzioni personalizzate al di sotto di specifiche quantità minime, mentre le produzioni standard sono disponibili in confezioni individuali. Gli ordini di soluzioni personalizzate sono soggetti a variazioni del 10% in eccesso o in difetto. Qualora il valore dell'ordine scenda al di sotto di una certa quota minima per gli articoli e gli effetti standard (per informazioni, consultare il Listino prezzi di Swarovski), sarà applicato un ulteriore addebito del 20%. Vi preghiamo di ricordare che le produzioni speciali potrebbero essere soggette a particolari tempi di consegna.

Per ulteriori informazioni e consigli in merito alle soluzioni personalizzate, vi invitiamo a contattare il Servizio Clienti della vostra zona.

* Disponibili per tutti i nostri clienti. Per ragioni di fattibilità tecnica e in seguito all'applicazione dei nostri Termini e condizioni, la disponibilità di soluzioni personalizzate potrebbe essere soggetta a limitazioni.

LEGGI, REGOLAMENTI, NORME E STANDARD

La composizione del cristallo Advanced Crystal e dei prodotti semifiniti nell'Advanced Crystal standard rispetta le norme industriali e le leggi relative alla limitazione o al divieto di utilizzo di determinate sostanze per prodotti finiti nei segmenti più rilevanti della nostra attività, tra cui:

Norme generali

- Presenza di piombo nei rivestimenti delle superfici stabiliti dalle norme 16 CFR 1303

Norme per i gioielli

- Limiti europei di rilascio del nichel per gioielli stabiliti dal regolamento REACH 1907/2006/EG
- Limiti europei in relazione al contenuto di cadmio per gioielli stabiliti dal regolamento REACH 1907/2006/EG
- Standard industriale cinese QB/T 2997-2008: Decorazione con rivestimento in metallo prezioso
- Limiti in relazione al contenuto di piombo nei gioielli e nei rivestimenti delle superfici stabiliti dalla legge California S.B. 646, che modifica il Codice di sicurezza e salute della California 25214.1 et seq. (comunemente nota come Legge sui gioielli della California)
- Disposizione per la limitazione degli elementi nocivi nelle decorazioni – Cina GB 28480-2012

Regolamenti per prodotti per bambini (3-14 anni)

- Limite in relazione al contenuto di piombo stabilito dalle norme 16 CFR 1500 (U.S. Consumer Product Safety Improvement Act), U.S. 74 Fed. Reg. 43031
- Direttiva 2009/48/EU sulla sicurezza dei giocattoli, allegato II, sezione III. 13 – limiti alla migrazione di metalli pesanti
- ASTM F963-11, sicurezza dei giocattoli, sezione 4.3.5.2., limiti alla migrazione di metalli pesanti
- ASTM F2923-11 Specifica standard per la sicurezza dei prodotti di consumo per gioielli per bambini
- Limiti alla migrazione del cadmio stabiliti da Illinois 430 ILCS 140, modificata dalla legge H.B. 5040 – Legge Cadmium-Safe Kids Act contro l'esposizione dei bambini al cadmio
- Limiti di migrazione del cadmio stabiliti negli statuti del Minnesota 325E.3891 – Cadmio nei gioielli per bambini
- California S.B. 929, che modifica il Codice di sicurezza e salute della California 25241.1 et seq.*
- Statuti generali del Connecticut 21a Sez. 21a-12d – Cadmio nei prodotti per bambini*
- Codice del Maryland 6-1402 – Cadmio nei gioielli per bambini*
- Legge sulla gestione della qualità e il controllo della sicurezza dei prodotti industriali in Corea*

Prodotti elettrici ed elettronici

Limiti in relazione al contenuto di metalli pesanti stabiliti dalla Direttiva europea RoHS (Direttiva 2011/65/EC)*, dalla legge coreana per il riciclaggio di prodotti elettrici/elettronici e automobili*, e dalla norma JIS (Japanese Industrial Standard, standard per le attività industriali giapponesi)*

Packaging

Limiti in relazione al contenuto di metalli pesanti stabiliti dalla Direttiva Europea sugli imballaggi 94/62/EC* e dal regolamento sulle sostanze tossiche negli imballaggi adottato da alcuni stati degli Stati Uniti (TPCH)*

Prodotti tessili

A parte alcune rare eccezioni, i cristalli Swarovski sono certificati come prodotti di Classe II dell'Oeko-Tex Standard 100 (prodotti a contatto con la pelle umana), un sistema internazionale di qualità relativo ai prodotti tessili. Per informazioni dettagliate sui cristalli Swarovski certificati dall'Oeko-Tex Standard 100, vi invitiamo a visitare il sito web WWW.SWAROVSKI.COM/PROFESSIONAL

* Si prega di notare che i seguenti colori del cristallo non sono conformi alle norme sopraindicate: Citrine, Fireopal, Hyacinth, Light Siam, Palace Green Opal, Siam e Sun.

Quanto sopra è da ritenersi valido per le attuali normative (in vigore dal marzo 2014), ma è necessario considerare che leggi e norme potrebbero cambiare in futuro e variare da paese a paese, pertanto non possiamo garantire la conformità a tutte le norme. Per informazioni aggiornate, vi invitiamo a visitare il nostro sito web B2B. La responsabilità finale relativa alla conformità per prodotti di terzi è da attribuirsi ai produttori del prodotto finito.

AVVISI

**Avvertenza generale**

Date le loro dimensioni, i cristalli sfusi possono rappresentare un pericolo per i bambini, in particolare se di età inferiore a tre anni. I cristalli di certe dimensioni e i materiali impiegati per la loro applicazione (ad es. colla, tessuto ecc.), possono esporre i bambini al rischio di soffocamento.

I bambini, inoltre, potrebbero inalare e ingerire i cristalli o introdurli nelle cavità nasali. I prodotti magnetici con applicazioni in cristallo potrebbero provocare gravi problemi intestinali in caso d'ingestione. Le tecniche di applicazione riportate nel presente manuale non garantiscono contro il possibile distacco dei cristalli. Per ogni applicazione, il produttore è tenuto a verificare che il prodotto soddisfi le norme vigenti in materia di rischi associati alle componenti di piccole dimensioni e di valutare qualunque altro rischio per i bambini. La mancata osservanza delle istruzioni per la cura dei prodotti fornite da Swarovski può comportare il danneggiamento dei cristalli con conseguente rischio di lacerazioni cutanee o altri infortuni.

Avvertenza per i Crystal Tattoos

I Crystal Tattoos possono essere applicati solo su pelle integra e sana. Non applicare il tatuaggio sugli occhi o sulle membrane mucose. Si sconsiglia l'uso dei Crystal Tattoos sui bambini. I cristalli sfusi possono comportare i rischi associati ai componenti di piccole dimensioni nel caso dei bambini, soprattutto se di età inferiore ai tre anni. Il distacco di cristalli di certe dimensioni può comportare il pericolo di soffocamento, ingestione o introduzione nelle cavità nasali.

Avvertenza per gli articoli da tavola

L'applicazione di cristalli sfusi su articoli per la tavola presenta rischi potenziali di aspirazione, soffocamento, ingestione e danneggiamento dei denti in caso di distacco dei cristalli. Per ridurre questo rischio, si raccomanda di non applicare mai i cristalli sulle superfici di articoli da tavola decorati con i cristalli, si raccomanda di lavarli a mano piuttosto che nel lavastoviglie. Le tecniche o i consigli per l'applicazione contenuti nel presente manuale non garantiscono contro il possibile distacco dei cristalli. Per ciascuna applicazione, il produttore è tenuto a valutare se il prodotto soddisfa i requisiti normativi vigenti in materia di rischi associati ai componenti di piccole dimensioni o all'impiego su prodotti a contatto con gli alimenti e di valutare ogni possibile rischio per l'utilizzatore. L'applicazione di cristalli (che possono contenere sostanze regolamentate e ritenute pericolose ai sensi delle leggi locali) e di adesivi sugli articoli da tavola è soggetta a restrizioni legali in alcuni Paesi. Al cliente spetta la responsabilità esclusiva di garantire l'ottemperanza alle norme locali, mallevando e tenendo indenne Swarovski rispetto a qualunque azione legale di terzi sulla responsabilità del prodotto o altresì correlata all'uso dei prodotti Swarovski. Il cliente rinuncia inoltre a qualunque diritto di intraprendere azioni legali contro Swarovski.

Applicazioni non idonee

I cristalli Swarovski possono essere utilizzati per la realizzazione di articoli di moda, gioielli e accessori, per prodotti tessili e oggetti per l'arredamento di interni. In ragione delle loro caratteristiche fisiche, i cristalli Swarovski non sono idonei per usi diversi (ad esempio, l'applicazione su denti o l'uso di cristalli in prossimità o a diretto contatto con mucose né per altri impieghi dannosi). Il cliente malleva e tiene indenne Swarovski rispetto a qualsiasi richiesta di terzi in merito alla responsabilità di prodotto o altresì correlata all'uso dei prodotti Swarovski, rinunciando ad intraprendere qualunque azione legale contro Swarovski.

Responsabilità dell'utente

Qualunque consiglio fornito da Swarovski in forma scritta, orale o come risultato di prove condotte in relazione alle tecniche di applicazione dei suoi prodotti, costituisce una raccomandazione basata sulle attuali conoscenze di Swarovski e sulle informazioni ricevute dai suoi fornitori. Detto consiglio non esonera il cliente dal condurre test indipendenti in relazione alle tecniche che intende utilizzare e alla loro idoneità per l'applicazione prevista. L'applicazione, l'uso e l'elaborazione di dette tecniche e prodotti rientrano esclusivamente nelle responsabilità dell'utente.

COLECCIONES

Swarovski es la empresa líder mundial en la producción de cristales tallados con gran precisión, que se utilizan tanto en las industrias de la moda y la bisutería, como también en el mundo de la iluminación, la arquitectura y el interiorismo. Los cristales Swarovski se han convertido en un material indispensable para las creaciones de diseñadores internacionales. Swarovski comercializa sus elementos de cristal sueltos y soluciones integradas en el mundo de la moda y el diseño bajo la marca de producto Swarovski.

El catálogo Collection ofrece una completa visión de toda la gama de productos y está también disponible en formato digital, a través de nuestra página web, WWW.SWAROVSKI.COM/PROFESSIONAL y en una nueva aplicación Collection para iPad que estará disponible para iTunes en abril de 2014.

Una dedicación total a la perfección y a la innovación ha sido la política que representa la piedra angular de la compañía desde su fundación en 1895. Esta búsqueda de la excelencia incluye el compromiso de Swarovski en la investigación de las tendencias de moda, que se traduce en la creación de elementos de cristal innovadores, así como en nuevos colores y efectos que se van añadiendo a la colección cada temporada. Estas innovaciones y ampliaciones de temporada se presentan en amplios paquetes de lanzamiento en febrero y septiembre y en un paquete de lanzamiento de pretemporada en mayo.

Dedicada a mantener el liderazgo en cristal tallado con precisión, Swarovski también ofrece a sus clientes colecciones específicas para cada sector y soluciones de producto personalizadas así como servicios de aplicación y asesoramiento en tendencias. Para obtener más información sobre los productos, servicios y materiales de venta de Swarovski, puede contactar con su delegación de ventas de Swarovski más cercana.

PEDIDOS

Les rogamos que se pongan en contacto con su delegación de ventas Swarovski más cercana para realizar pedidos. Los clientes registrados también tienen la posibilidad de cursar sus pedidos online a través del servicio de comercio electrónico, WWW.B2B.ECOMMERCE.SWAROVSKI.COM. Además de ofrecer la posibilidad de gestionar pedidos online, el sitio web también incluye valiosa información sobre productos, disponibilidad, detalles sobre la entrega, etc. Contacte con su delegación local de ventas de Swarovski para registrarse y tener acceso a este servicio.

INFORMACIÓN SOBRE APLICACIÓN

Gracias a su excelente calidad y con ayuda de técnicas de aplicación especialmente desarrolladas, los cristales Swarovski se pueden aplicar con facilidad y rapidez y obtener un resultado de gran calidad.

El Manual de Aplicación contiene información detallada sobre todas las técnicas de aplicación actuales así como también los servicios técnicos de Swarovski. Contiene ilustraciones e instrucciones detalladas para soldadura, galvanizado, pegado, Ceralun™, cosido, bordado, aplicación Hoffix y aplicaciones mecánicas, útiles instrucciones sobre el cuidado e información sobre las máquinas, herramientas y accesorios necesarios y sus proveedores. El manual está disponible en varios idiomas.

Toda la información detallada y actualizada del Manual de Aplicación también está disponible en el sitio web

WWW.SWAROVSKI.COM/PROFESSIONAL. Las técnicas de aplicación vienen acompañadas de vídeos y animaciones. Póngase en contacto con su representante local de Swarovski para acceder al área de clientes del sitio web.

Para preguntas específicas sobre las técnicas de aplicación, póngase en contacto con su delegación de ventas local Swarovski.

ARTÍCULOS PARCIALMENTE TALLADOS Y SIN TALLAR

La colección estándar no sólo incluye artículos tallados, sino que también podemos encontrar artículos tallados parcialmente o sin tallar.

/3

El cristal no ha sido tallado, pero las facetas han sido prensadas.



/4

El cristal no ha sido tallado y no tiene facetas (por ej. art. 2080/4).

MEDIDAS

Se utilizan diversas abreviaturas de medición para clasificar las piedras de bisutería.

**PP, SS**

PP (Pearl Plate), SS (Sieve Size o Stone Size) para cristales redondos. Consulte también la tabla de conversión que encontrará al final del catálogo ("Open to See Sizes").

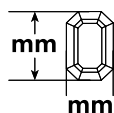
**mm**

Medición en milímetros.

COLORES Y EFECTOS**Colores y efectos clásicos**

La gama de colores clásicos ofrece una amplia variedad de colores de cristal, que incluyen todos los colores clásicos del sector de la bisutería. La combinación creativa de los colores disponibles puede dar como resultado un efecto original y rico en matices.

Colores y efectos exclusivos

La gama de colores exclusivos incluye colores de cristal totalmente en línea con las últimas tendencias y que han sido lanzados al mercado exclusivamente por Swarovski. Cada color, desarrollado en cooperación con agencias de tendencias de moda internacionales, lleva el inconfundible distintivo de calidad y creatividad de Swarovski. Los colores y efectos exclusivos son fácilmente reconocibles en las matrices de productos porque sus nombres están subrayados.

Los colores y efectos pueden variar con distintos tipos de luz. Swarovski utiliza la fuente de luz estándar D50 para decidir y comparar los colores.

Al inicio de cada capítulo se presenta una carta con los colores especiales para varios grupos de productos.

Categorías y efectos de colores

En las matrices de productos, los colores y efectos siguen una segmentación específica:

Cristal
Cristal (001), con talco o sin talco
Colores
Colores planos
Colores planos disponibles
Colores ópalo
Colores ópalo disponibles
Fusión de colores
Fusión de colores disponibles
Cerámicos
Colores cerámicos disponibles
Colores
Colores
Colores planos disponibles
Colores de gemas
Colores de gemas disponibles
Colores Neón
Colores Neón disponibles
Efectos de cristal o Efectos de color
Efectos transparentes
Efectos transparentes disponibles
Efectos metálicos
Efectos metálicos disponibles
Revestimiento total
Efectos de revestimiento total disponibles
Pátina de cristal
Efectos de pátina de cristal disponibles

Para cristales

Para Crystal pearls

LISH	Lilac Shadow
LUMG	Luminous Green
METBL	Metallic Blue
MLGLD	Metallic Light Gold
MOL	Moonlight
NUT	Nut (sólo en Jet)
REDM	Red Magma
ROGL	Rose Gold
SAT	Satin
SSHA	Silver Shade
TRA	Transmission

Efectos traslúcidos

(Vaporización en el reverso del cristal, el efecto brilla a través del cristal transparente)



Código del efecto	Nombre
BBL	Bermuda Blue
HEL	Heliotrope
MBL	Meridian Blue
SINI	Silver Night
TAB	Tabac
VL	Vitrail Light
VM	Vitrail Medium
VOL	Volcano

Efectos de pátina

Código del efecto	Nombre
BLAPA	Black Patina
GOLPA	Gold Patina
ROSPA	Rose Patina
SILPA	Silver Patina
WHIPA	White Patina

Variaciones en los efectos aplicados en la superficie



2x
Se aplica un efecto en ambos lados del cristal (por ej. AB 2).



B
Efectos en tres lados de una forma cúbica (por ej. AB B).



V
El efecto se usa al contrario. Un efecto aplicado en la superficie es utilizado como un efecto traslúcido (por ej. SSHA V – Silver Shade en el reverso).



Z
El efecto sólo se aplica en una parte del cristal (por ej. HEL Z).

EFFECTOS

Los procesos de vaporización realizados en la superficie del cristal producen efectos especiales o traslúcidos según el método de aplicación utilizado.

A continuación detallamos una lista de todos los efectos Swarovski, seguida de una explicación de los procesos especiales de vaporización.

Efectos en la superficie

(Vaporización sobre la superficie del cristal)



Código del efecto	Nombre
AB	Aurore Boreale
ANTP	Antique Pink
API	Astral Pink
BLSH	Blue Shade
BRSH	Bronze Shade
CAL	Comet Argent Light
COP	Copper
DOR	Dorado
GSHA	Golden Shadow
HEM	Hematite (sólo en Jet)
IRIG	Iridescent Green

FC (Full Coated - completamente revestido)

Las mejoras tecnológicas crean aplicaciones perfectamente homogéneas y aplicaciones integrales de efectos metálicos de alta intensidad en la gama Bead (art. 5000).

CAL 'V' SI & CAL 'VZ' SI

El efecto CAL (Comet Argent Light) se utilizará también como recubrimiento reflectante en el reverso del cristal en lugar de los talcos estándar (A, F, ...) en casos especiales (por ejemplo, en los artículos de Knobs, Handles & Co.).

/G

Artículo con superficie parcial (PF) o completamente esmerilada (FF) (por ejemplo art. 2611/G)

PA (Patina)

Las innovaciones tecnológicas crean aplicaciones parcialmente recubiertas de efectos adaptados. Su carácter histórico y look „usado“ aportan atemporalidad sin perder el efecto cristalino.

Efectos especiales sobre la superficie

Swarovski ha podido lograr diversos efectos especiales utilizando procesos químicos y mecánicos en la superficie de los cristales.



MAT



COS

Código del efecto

MAT
COS

Nombre

Matt Finish
Cosmojet

El efecto Matt Finish se logra realizando un proceso químico de mateado en toda la superficie del cristal. Este proceso puede producir ligeras variaciones en el tamaño de los artículos. Mediante un proceso especial, se pueden oscurecer las facetas exteriores de los Flat Back Roses. El efecto Cosmojet solo se puede realizar con el color Crystal (001).

SIMILIZACIÓN

El proceso de similitud consiste en recubrir la parte posterior del cristal con una lámina metalizada para obtener un efecto espejo.



Talco en plata (A)

Un efecto espejo plateado para artículos XIRIUS y XILION Hotfix exclusivamente.



Talco en platino pro (F)

El efecto espejo es plateado y se recubre con una capa protectora de color platino de la mejor calidad. El talco en platino pro no sólo es resistente a los daños ambientales causados por el cloro, el agua salada y los perfumes, sino que también es resistente a los procesos como la soldadura y la galvanoplastia, aportando una durabilidad sin precedentes.



Talco aluminio (M)

El efecto espejo es aluminio y se aplica utilizando un proceso de vaporización.



Capa protectora (P) para Beads y Pendants

La capa protectora es un sistema de lacado transparente que se aplica sobre todos los efectos. La laca se ha diseñado para proteger los efectos frente a arañazos, huellas y otros daños. Además, evita la humedad que puede causar corrosión (por ejemplo, de la transpiración) penetrando en la capa del efecto cuando el artículo se ha diseñado para incorporar cristales que no están engarzados en bases o engastes.



Sin talco (U)

TECNOLOGÍA HOTFIX

Hotfix (HF)

La tecnología Hotfix consiste en aplicar un adhesivo desarrollado especialmente para la parte posterior de los cristales Flat Backs. El adhesivo, que es sumamente flexible, se activa a temperaturas de 120 °C, con la posibilidad de aplicarse a hasta 170 °C, y se adhiere al material de base. El elemento de cristal se fija de manera permanente al material de base durante el proceso de enfriamiento.

Hotfix Transparente (HFT)

Esta variante de la tecnología Hotfix es un adhesivo patentado que se aplica en la parte posterior de los cristales Flat Backs sin talco dando como resultado un efecto de “gotas de lluvia” por el que el cristal toma el color del material en el que queda aplicado.

No Hotfix (No HF)

Los artículos Hotfix también están disponibles como No Hotfix, es decir sin adhesivo en la parte posterior. Para más información, póngase en contacto con el servicio de Atención al cliente.

SOLUCIONES PERSONALIZADAS

Swarovski ofrece soluciones personalizadas además de la colección estándar*.

Podemos considerar como soluciones personalizadas las siguientes opciones:

- **Artículos estándar con colores y efectos no estándar**
- **Artículos estándar con motivos/serigrafías**
- **Tallas y tamaños no estándar**
- **Desarrollo de productos personalizados**
- **Elementos personalizados integrados**

Por motivos técnicos, las soluciones personalizadas pueden estar sujetas a una cantidad mínima de pedido, mientras que los artículos estándar están disponibles en paquetes individuales. Las soluciones personalizadas están sujetas a una tolerancia máxima o mínima de entrega de un 10%. En caso de que el valor de un artículo esté por debajo de un cierto mínimo para artículos estándar en colores y efectos no estándar (consultar la Lista de Precios Swarovski para más detalles) se aplicará un recargo adicional del 20%.

Tenga en cuenta que los plazos de entrega para estas producciones especiales pueden diferir de los habituales, según cada caso.

Para más información y asesoramiento sobre soluciones personalizadas contacte con el Depto. de Atención al Cliente.

* Disponible para todos nuestros clientes. La disponibilidad de soluciones personalizadas puede ser limitada según su viabilidad técnica y si se aplican nuestros Términos y Condiciones.

LEGISLACIÓN, NORMATIVA Y ESTÁNDARES

La composición de Advanced Crystal y de los productos integrados en el estándar Advanced Crystal cumple las normas reguladoras de la industria y la legislación relativa a la restricción o prohibición de determinadas sustancias para productos terminados en los sectores más relevantes de negocio de nuestros clientes, incluyendo:

General

- Plomo en recubrimientos de superficie tal como se establece en 16 CFR 1303

Normativas para Bisutería

- Límites europeos de liberación de níquel en bisutería que figuran en el Reglamento REACH 1907/2006/EG
- Límites europeos de contenido en cadmio de la bisutería que figuran en el Reglamento REACH 1907/2006/EG
- Estándar Industrial de China GB/T 2997-2008 Adornos con Recubrimiento metálico precioso
- Límites de plomo en bisutería y recubrimientos de superficie tal como se establece en California S.B. 646, que modifica el Código de Seguridad y Salud de California 25214.1 et seq. (comúnmente conocida como la Ley de Bisutería de California)
- Estándar de China GB 28480-2012 relativo al límite de elementos nocivos en adornos

Normativas para productos para niños (3-14 años)

- Límite de plomo tal como se establece en 16 CFR 1500 (Ley de Mejora de la Seguridad de los Productos de Consumo, CPSIA), Reg. Fed. 74 U.S. 74 43031
- Directiva 2009/48/EU, Seguridad de los juguetes, anexo II, sección III.13 – límites de migración de metales pesados
- ASTM F963-11, Seguridad de los juguetes, sección 4.3.5.2., límites de migración de metales pesados
- ASTM F2923-11 Especificación estándar para la Seguridad de Productos de Consumo para la bisutería para niños
- Límites de migración de cadmio tal como se establece en Illinois 430 ILCS 140, modificada por H.B. 5040 – Ley de Seguridad de Cadmio para niños
- Límites de migración de cadmio tal como se establece en los Estatutos de Minnesota 325E.3891 – Cadmio en Bisutería para niños
- California S.B. 929, que modifica el Código de Seguridad y Salud de California 25241.1 et seq.*
- Est. Gen. de Connecticut 21a Sec 21a-12d – Cadmio en productos para niños*
- Código de Maryland 6-1402 – Cadmio en bisutería para niños*
- Gestión de Calidad y Control de Seguridad de Corea de la Ley de Productos industriales*

Productos Eléctricos y Electrónicos

Límites en el contenido de metales pesados tal como se establecen en las RoHS europeas (Directiva 2011/65/EC)*, Ley coreana para reciclar recursos de Productos eléctricos/electrónicos y Automóviles*, y el Estándar industrial japonés (JIS)*

Embalaje

Límites de contenido de metales pesados tal como se establecen en la Directiva Europea de Envasado 94/62/EC* y Tóxicos en las Normativas de Embalaje aprobadas por determinados estados de EE.UU. (TPCH)*

Productos textiles

Los cristales Swarovski, con muy pocas excepciones, están certificados por la Norma Oeko-Tex 100 Clase II (productos en contacto con la piel), una etiqueta internacional para textiles inofensivos. Para más información sobre qué cristales Swarovski cumplen con el Estándar Oeko-Tex 100, visite WWW.SWAROVSKI.COM/PROFESSIONAL

* Tenga en cuenta que los siguientes colores de cristal no son conformes con las normativas anteriormente mencionadas: Citrine, Fireopal, Hyacinth, Light Siam, Palace Green Opal, Siam y Sun.

Esto es válido para normativas actuales (a partir de marzo de 2014), pero debe considerarse que las normativas y leyes pueden cambiar en el futuro y variar de un país a otro. Por tanto, no podemos garantizar el cumplimiento de todas las normativas. Para información actualizada visite nuestra página web B2B. La responsabilidad final sobre el cumplimiento de productos acabados por terceros es de los fabricantes del producto terminado.

AVISOS

Advertencia General



Los cristales sueltos, debido a su reducido tamaño, pueden suponer un riesgo para los niños pequeños, en particular para los menores de tres años. Dependiendo del tamaño del cristal y del material de fijación (como pegamento, tejido, etc.), los niños pueden atragantarse, ingerir los cristales o introducirse en la nariz. Los productos magnéticos con aplicaciones de cristal suponen un riesgo especial de lesión intestinal en caso de ingestión. Las técnicas de aplicación detalladas en este catálogo no garantizan que los cristales no se desprendan. Para cada aplicación, el fabricante debe determinar si el producto cumple con los requisitos pertinentes referentes al peligro que supone utilizar piezas pequeñas y valorar cualquier riesgo que puedan suponer para los niños pequeños. Si no se siguen las instrucciones de cuidado de Swarovski se puede dañar el cristal, lo cual puede constituir un riesgo de laceración u otros daños.

Advertencia sobre Crystal Tattoos

Los Crystal Tattoos sólo pueden aplicarse sobre piel que se encuentre en perfecto estado. No deben aplicarse en los ojos o en membranas mucosas. No se recomienda el uso de los Crystal Tattoos en niños pequeños, ya que los cristales sueltos, debido a su reducido tamaño, pueden suponer un riesgo, en particular para los menores de tres años. Si se desprende un cristal, según su tamaño, los niños pueden atragantarse, ingerir los cristales o introducirse en la nariz.

Advertencia sobre los servicios de mesa

La aplicación de cristales sueltos a servicios de mesa presenta un riesgo potencial de que sean inhalados, ingeridos o que causen atragantamientos o daños en los dientes si los cristales se desprenden. Para reducir este riesgo, nunca deben aplicarse cristales a ningún artículo de servicio de mesa que pueda entrar en contacto con los alimentos o la boca, y nunca deben aplicarse cristales en ningún artículo de servicio de mesa destinado a ser utilizados por niños. Los artículos de servicio de mesa con cristales que estén destinados únicamente a usos decorativos, deben estar indicados como tales. Para evitar daños en el lavavajillas, estos artículos decorados con cristales deben lavarse a mano. Las técnicas de aplicación o sugerencias de este manual no garantizan que los cristales no se desprendan. Para cada aplicación, el fabricante debe determinar si el producto cumple con los requisitos pertinentes referentes a los riesgos presentados por utilizar piezas pequeñas o el uso en artículos que estén en contacto con los alimentos y evaluar cualquier riesgo que pueda constituir para los usuarios.

El uso de cristales (que puedan contener sustancias restringidas consideradas peligrosas bajo leyes locales) y adhesivos en artículos de servicio de mesa está sujeto a restricciones legales en países específicos. El cliente es totalmente responsable del cumplimiento de estas disposiciones específicas de cada país y defenderá, indemnizará y protegerá a Swarovski contra toda demanda por parte de terceros basada en responsabilidad respecto al uso del producto de otro tipo en relación con los usos de productos Swarovski y renuncia a todas sus propias demandas contra Swarovski.

Aplicaciones No Recomendadas

Los cristales Swarovski están pensados para las industrias de la moda, bisutería, accesorios, productos textiles y decoración de interiores. Por sus características físicas, los cristales Swarovski no están recomendados para otros usos (por ej., fijación sobre la dentadura, aplicación en o cerca de las membranas mucosas y otros usos que puedan considerarse peligrosos). El cliente deberá defender, indemnizar y mantener a Swarovski al margen de cualquier reclamación basada en la responsabilidad respecto al uso de los productos Swarovski que hayan sido comprados por el cliente y renunciar a sus propias reclamaciones.

Responsabilidad del cliente

El asesoramiento proporcionado de forma verbal, por escrito o basado en pruebas que Swarovski proporciona sobre las diferentes técnicas de aplicación de sus productos son recomendaciones basadas en nuestros conocimientos actuales y la información facilitada por nuestros proveedores. No obstante, estas recomendaciones no le eximen de realizar sus propias pruebas con respecto a las técnicas propuestas y de comprobar su idoneidad para la aplicación deseada. La aplicación, el uso y el procesamiento de estas técnicas y productos son responsabilidad exclusiva del cliente.

CATÁLOGO

A Swarovski é a principal fabricante de cristais precisamente lapidados, utilizados nas indústrias da moda e joalheria, assim como nos segmentos de iluminação, arquitetura e design de interiores. Os cristais da Swarovski tornaram-se indispensáveis para as criações de designers internacionais. A empresa comercializa componentes de cristal e soluções de integração direta para os setores de moda e design sob a marca Swarovski. Este catálogo apresenta uma visão completa de toda a gama de produtos. Todas as informações sobre os produtos encontram-se igualmente disponíveis para download através do site da empresa em WWW.SWAROVSKI.COM/PROFESSIONAL e no novo aplicativo para iPad que está disponível no iTunes desde abril de 2014.

Desde sua fundação em 1895, a Swarovski tem um compromisso com a perfeição e a inovação. Esta busca pela excelência inclui a pesquisa de tendências, o que resulta na criação de modernas lapidações de cristal, assim como novos efeitos e cores presentes na seleção de cada estação Primavera/Verão e Outono/Inverno. Essas inovações e extensões de linhas sazonais são apresentadas em amplos pacotes de comunicação de lançamentos todos os meses de Fevereiro e Setembro e num pacote de lançamentos de pré-temporada em Maio.

Dedicada a permanecer no topo como líder mundial de cristais precisamente lapidados, a Swarovski apresenta ainda catálogos específicos para determinados segmentos e soluções de produtos personalizados para seus clientes, assim como serviços de apoio em tendências da moda, bem como informações sobre aplicação. Para mais informações sobre os produtos, serviços e materiais de comunicação da Swarovski, contate o escritório da Swarovski mais próximo.

VENDAS

Contate o escritório local da Swarovski para encomendar produtos. Clientes cadastrados dispõem ainda da conveniente opção de compras on-line, através do serviço de comércio eletrônico em WWW.B2B.ECOMMERCE.SWAROVSKI.COM. Além de disponibilizar um sistema de compras on-line, o site inclui valiosas informações sobre produtos, disponibilidade e detalhes de entrega, etc. Contate o seu gerente de conta Swarovski para aderir a este serviço. Comercial.br@swarovski.com

INFORMAÇÃO SOBRE APLICAÇÃO

Graças à sua excelente qualidade e com a ajuda de técnicas de aplicação especialmente desenvolvidas, os cristais da Swarovski podem ser fácil e rapidamente aplicados com acabamento de alta qualidade.

O Manual de Aplicação inclui informações detalhadas relativas a todas as técnicas de aplicação atuais e aos serviços de suporte oferecidos pela Swarovski. Contém ilustrações e instruções detalhadas para a correta soldagem, galvanoplastia, colagem, técnica Ceralun™, costura, bordado, aplicação Hotfix e aplicação mecânica, assim como instruções úteis sobre os cuidados necessários e informações sobre as máquinas, ferramentas, equipamentos auxiliares e seus respectivos fornecedores. O manual está disponível em vários idiomas.

Todas as informações detalhadas e atualizadas sobre o Manual de Aplicação estão também disponíveis no site

WWW.SWAROVSKI.COM/PROFESSIONAL. As técnicas de aplicação são também demonstradas em animações e vídeos. Contate seu gerente de contas na Swarovski para obter acesso à área interna do site da empresa.

Para questões específicas sobre as técnicas de aplicação, contate o departamento de vendas local da Swarovski.

ARTIGOS PARCIALMENTE LAPIDADOS E NÃO LAPIDADOS

O catálogo principal não inclui apenas artigos lapidados, mas também artigos parcialmente lapidados ou não lapidados.

/3

O cristal não é lapidado, mas possui facetas moldadas.



/4

O cristal não é lapidado nem possui facetas (ex., art. 2080/4).

TAMANHOS

Existem várias abreviaturas de medição utilizadas para classificar as pedras para o segmento de bijuterias.



PP, SS

Pearl Plate (PP), Sieve Size ou Stone Size (SS) para cristais redondos. Consulte ainda a tabela de conversão no verso do catálogo ("Open to See Sizes").

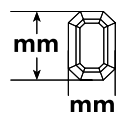

mm

Medidas métricas em milímetros.

CORES E EFEITOS

Cores e efeitos clássicos

A paleta de cores oferece uma vasta gama de cores de cristais, incluindo todas as cores clássicas de joalheria. A associação criativa das cores disponíveis pode resultar em combinações que, além de originais, são também ricas em nuances.

Cores e efeitos exclusivos

Única, a paleta oferece cores de cristais que garantem a sua aplicação na moda atual e são exclusivamente lançadas pela Swarovski. Cada cor, desenvolvida em colaboração com agências internacionais de moda, assume a inconfundível marca de qualidade e criatividade da Swarovski. As cores e efeitos exclusivos podem ser reconhecidos pelos nomes sublinhados nas matrizes de produtos.

As cores e efeitos podem parecer diferentes quando iluminados por diferentes fontes de luz. A Swarovski utiliza a fonte de luz padrão D50 para decisões e comparações de cores.

No início de cada capítulo, apresentamos índices de cores especiais para os vários grupos de produtos.

Categorias de cores e efeitos

Nas matrizes de produtos, as cores e efeitos seguem uma segmentação específica:

Cristal
Cristal (001), com ou sem metalização
Cores
Cores simples
Cores simples disponíveis
Cores opalinas
Cores opalinas disponíveis
Cores Crystal Blend
Cores Crystal Blend disponíveis
Cerâmicas
Cores cerâmicas disponíveis
Cores
Cores
Cores simples disponíveis
Gemcolors
Gemcolors disponíveis
Neoncolors
Neoncolors disponíveis
Efeitos de cristal ou efeitos de cores
Efeitos transparentes
Efeitos transparentes disponíveis
Efeitos metálicos
Efeitos metálicos disponíveis
Revestimento total
Efeitos de revestimento total disponíveis
Pátina de cristal
Efeitos pátina de cristal disponíveis

Para cristais

Para pérolas de cristal

METBL	Metallic Blue
MLGLD	Metallic Light Gold
MOL	Moonlight
NUT	Nut (apenas na cor Jet)
REDM	Red Magma
ROGL	Rose Gold
SAT	Satin
SSHA	Silver Shade
TRA	Transmission

Efeitos translúcidos

(Revestimento por vácuo no verso do cristal; o efeito reluz através do cristal transparente)



Código do efeito	Nome
BBL	Bermuda Blue
HEL	Heliotrope
MBL	Meridian Blue
SINI	Silver Night
TAB	Tabac
VL	Vitrail Light
VM	Vitrail Medium
VOL	Volcano

Efeitos de pátina

Código do efeito	Nome
BLAPA	Black Patina
GOLPA	Gold Patina
ROSPA	Rose Patina
SILPA	Silver Patina
WHIPA	White Patina

Variações nos efeitos de superfície



2x
Ambos os lados da pedra são tratados com um efeito (por ex., AB 2).



B
Efeitos nos três lados de uma forma cúbica (por ex., AB B).



V
O efeito de superfície é utilizado no verso do cristal. Um efeito de superfície é utilizado como um efeito translúcido (por ex., SSHA V – Silver Shade no verso do cristal).



Z
Apenas uma parte da pedra é tratada com um efeito (por ex., HEL Z).

EFEITOS

Os processos de revestimento por vácuo na superfície dos cristais produzem efeitos especiais ou translúcidos, dependendo do método de aplicação utilizado.

A seguir, apresentamos uma lista de todos os efeitos Swarovski, acompanhados de uma explicação dos processos de revestimento por vácuo.

Efeitos de superfície

(Revestimento por vácuo na superfície do cristal)



Código do efeito	Nome
AB	Aurore Boreale
ANTP	Antique Pink
API	Astral Pink
BLSH	Blue Shade
BRSH	Bronze Shade
CAL	Comet Argent Light
COP	Copper
DOR	Dorado
GSHA	Golden Shadow
HEM	Hematite (apenas na cor Jet)
IRIG	Iridescent Green
LISH	Lilac Shadow
LUMG	Luminous Green

FC (Revestimento total)

A tecnologia avançada cria uma aplicação de efeitos metálicos de alta intensidade perfeitamente homogênea em toda a volta na linha Beads (artigo 5000).

CAL 'V' SI e CAL 'VZ' SI

Em casos especiais, o efeito CAL (Comet Argent Light) também será utilizado como um revestimento espelhado no verso do cristal, em vez de metalizações padrão (A, F, ...) (por exemplo, puxadores, maçanetas, etc.).

/G

Artigo com superfície parcialmente (PF) ou totalmente (FF) fosca (por ex., artigo 2611/G)

PA (Pátina)

A tecnologia inovadora cria uma aplicação parcialmente revestida de efeitos adaptados. Seu toque histórico e visual "usado" confere atemporalidade à peça, sem perder o aspecto cristalino.

Efeitos especiais de superfície

A Swarovski revelou ser capaz de apresentar vários efeitos especiais de superfície ao longo do tempo, utilizando processos químicos e mecânicos na superfície dos cristais.



MAT



COS

Código do efeito

MAT

COS

Nome

Matt Finish

Cosmojet

O efeito Matt Finish é alcançado através de um processo químico com acabamento mate em toda a superfície do cristal. Podem ocorrer pequenas variações no tamanho dos artigos como resultado desse processo químico. Através de um processo especial, as facetas externas de Flat Back Roses podem ser escurecidas. O efeito Cosmojet só é possível para a cor Crystal (001).

REVESTIMENTO DE ESPELHO

Trata-se do processo de aplicação do espelho que reveste o verso dos cristais.

**Revestimento de prata (A)**

Um acabamento de espelho prateado apenas para artigos Hotfix XIRIUS e XILION.

**Revestimento Platinum Pro (F)**

Um acabamento de espelho prateado revestido e protegido com uma camada platinada da mais alta qualidade.

O revestimento Platinum Pro, além de resistente a danos ambientais, como cloro, água salgada e perfume, também pode resistir a processos como soldagem e folheação, apresentando uma durabilidade ainda maior.

**Revestimento de alumínio (M)**

É aplicado um acabamento de espelho em alumínio, recorrendo a um processo de revestimento a vácuo.

**Camada Protetora (P) para contas e pendentes**

A camada protetora consiste num sistema que utiliza verniz transparente aplicado sobre os efeitos. Este verniz destina-se a proteger os efeitos de arranhões, impressões digitais e outros danos, bem como a evitar que a umidade (como, por exemplo, da transpiração) possa levar à corrosão da camada de efeito quando a bijuteria visa incorporar cristais que não sejam fixados em cavidades ou caixilhos.

**Sem revestimento de espelho (U)****TECNOLOGIA HOTFIX****Hotfix (HF)**

A tecnologia Hotfix envolve a aplicação de cola especialmente desenvolvida no verso dos Flat Backs. A cola, extremamente flexível, é ativada a uma temperatura de 120 °C, fixando-se ao material. A peça de cristal fica permanentemente colada ao material durante o processo de arrefecimento.

Hotfix Transparente (HFT)

Esta variante da tecnologia Hotfix é um agente patenteado de fixação aplicado no verso dos Flat Backs sem acabamento de espelho, resultando num interessante efeito de "gota de chuva", no qual o cristal adquire a cor da superfície em que foi aplicado.

No Hotfix (No HF)

Os artigos Hotfix estão disponíveis também como artigos No Hotfix, que não têm cola aplicada no verso do cristal.

SOLUÇÕES PERSONALIZADAS

A Swarovski disponibiliza soluções personalizadas além das possibilidades oferecidas no catálogo*.

As seguintes soluções personalizadas podem ser oferecidas:

- Artigos standard em cores e efeitos não standard
- Artigos standard com motivos/impressões
- Lapidações e tamanhos não standard
- Desenvolvimento de produtos personalizados
- Componentes de integração direta personalizados

Devido a questões de ordem técnica, as soluções personalizadas podem estar sujeitas a um pedido mínimo, enquanto os artigos padrão estão disponíveis em embalagens individuais. Em soluções personalizadas, as quantidades estão sujeitas a uma variação de 10% para mais ou para menos. Caso o valor de uma encomenda seja inferior ao mínimo determinado para artigos standard em cores e efeitos não standard (para mais informações, consulte a lista de preços da Swarovski), será aplicada uma sobretaxa de 20%.

Tenha em consideração que as soluções personalizadas podem estar sujeitas a prazos de entrega diferentes do padrão.

Para mais informações e sugestões sobre as soluções personalizadas, contate nosso serviço de atendimento ao cliente.

* Disponível a todos os clientes. A disponibilidade de soluções personalizadas pode ser limitada em termos de viabilidade técnica e se nossos Termos e Condições forem aplicados.

LEIS, REGULAMENTOS, NORMAS E PADRÕES

A composição do Advanced Crystal é de produtos de integração direta no padrão Advanced Crystal segue as normas e regulamentos do setor quanto à restrição ou proibição de certas substâncias para produtos finalizados nos segmentos mais relevantes dos nossos clientes, incluindo:

Gerál

- Chumbo no revestimento de superfície conforme definido em na norma 16 CFR 1303

Regulamentos para joias

- Limites de liberação de níquel para joias na Europa conforme estabelecidos no regulamento REACH 1907/2006/EG
- Limites de conteúdo de cádmio para joias na Europa conforme estabelecidos no regulamento REACH 1907/2006/EG
- Padrão industrial chinês QB/T 2997-2008 Adorno com cobertura de metal precioso
- Limites de chumbo em joias e revestimentos de superfície conforme estabelecidos na Califórnia S.B. 646, emendando o California Health & Safety Code (Código de Saúde e Segurança da Califórnia) 25214.1 e seguintes (vulgarmente conhecido como California Jewelry Law, Lei das Joias da Califórnia)
- China GB 28480-2012 Disposição de limite de elementos nocivos em adornos

Regulamentos para produtos infantis (3-14 anos)

- Limite de chumbo conforme estabelecidos em na norma 16 CFR 1500 (U.S. Consumer Product Safety Improvement Act, CPSIA, ou Lei de Aperfeiçoamento da Segurança de Produtos ao Consumidor dos EUA), U.S. 74 Fed. Reg. 43031
- Diretiva 2009/48/EU, Segurança de brinquedos, anexo II, seção III.13 – limites de migração de metais pesados
- ASTM F963-11, Segurança de brinquedos, seção 4.3.5.2., limites de migração de metais pesados
- ASTM F2923-11, Especificação padrão para a segurança de produtos ao consumidor relativa a joias infantis
- Limites de migração de cádmio conforme estabelecidos em Illinois 430 ILCS 140, emendado por H.B. 5040 – Cadmium-Safe Kids Act, ou Lei para a Proteção das Crianças contra o Cádmio
- Limites de migração de cádmio conforme estabelecidos nas Leis de Minnesota 325E.3891 – Cadmium in Children's Jewelry, ou Cádmio em Joias Infantis
- Califórnia S.B. 929, emendando o California Health & Safety Code (Código de Saúde e Segurança da Califórnia) 25241.1 e seguintes*
- Est. Gerais de Connecticut 21a Sec 21a-12d – Cádmio em Produtos Infantis*
- Código de Maryland 6-1402 – Cádmio em Produtos Infantis*
- Lei de Gestão de Qualidade Coreana e Controle de Segurança de Produtos Industriais (Korean Quality Management and Safety Control of Industrial Products Act)*

Produtos elétricos e eletrônicos

Limites de conteúdo de metais pesados conforme estabelecidos na diretiva RoHS europeia (Diretiva 2011/65/EC)*, Korean Act for Resource Recycling of Electrical/Electronic Products and Automobiles (Lei Coreana para Reciclagem de Recursos de Produtos Elétricos/Eletrônicos e Automóveis)* e Japanese Industrial Standard (JIS, ou Normas Industriais Japonesas)*

Embalagem

Limites de conteúdo de metais pesados conforme estabelecidos na European Packaging Directive (Diretiva Europeia para Embalagens) 94/62/EC* e nos Toxics in Packaging Regulations (Regulamentos para Substâncias Tóxicas em Embalagens) conforme adotados por certos estados norte-americanos (TPCH)*

Produtos Têxteis

Os cristais da Swarovski, com muito poucas exceções, são certificados com o padrão Oeko-Tex Standard 100 Classe II (produtos em contato com a pele), um selo de qualidade internacional para tecidos que não oferecem perigo à saúde. Para saber exatamente quais cristais da Swarovski seguem o padrão Oeko-Tex Standard 100, visite WWW.SWAROVSKI.COM/PROFESSIONAL

* Observe que as cores de cristais a seguir não estão em conformidade com os regulamentos informados acima: Citrine, Fireopal, Hyacinth, Light Siam, Palace Green Opal, Siam e Sun.

Isto é válido para as leis atuais (desde março de 2014), mas deve-se considerar que as leis e os regulamentos podem ser alterados no futuro e que variam em cada país. Portanto, não podemos garantir a conformidade com todos os regulamentos. Para obter informações atualizadas, visite o nosso site B2B (de relacionamento entre empresas). A responsabilidade final com relação à conformidade de produtos com acabamento de terceiros é dos fabricantes do produto finalizado.

ADVERTÊNCIAS**Advertências Gerais**

Os cristais soltos podem constituir um perigo para as crianças devido a sua dimensão reduzida, em particular para crianças com idade inferior a 3 anos. Dependendo do tamanho do cristal e qualquer material que o constitua (tal como cola, tecido, etc.), as crianças podem sufocar, inalar, engolir ou inserir o cristal no nariz. Em caso de ingestão, os produtos magnéticos com aplicações de cristal podem acarretar lesões intestinais graves. As técnicas de aplicação, como referido no Manual de Aplicação, não garantem a fixação total dos cristais. Para cada aplicação o fabricante deve determinar se o produto está em conformidade com os requisitos relevantes relacionados com os perigos dos componentes de dimensão reduzida e avaliar quaisquer riscos para as crianças. O não cumprimento das instruções da Swarovski sobre cuidados necessários pode provocar danos no cristal, que podem representar um risco de laceração ou outras lesões.

Advertência relativa a tatuagens de cristal

As tatuagens de cristal podem ser aplicadas exclusivamente sobre pele saudável. Não aplicar sobre os olhos ou membranas mucosas. As tatuagens de cristal não são recomendadas para crianças. Os cristais soltos podem representar um perigo de peças pequenas para as crianças, sobretudo para crianças com menos de três anos. Se um cristal se soltar, dependendo da dimensão do mesmo, as crianças podem ser vítimas de asfixia, inalar, engolir ou introduzir o cristal no nariz.

Advertência relativa a artigos de mesa

A aplicação de cristais soltos em artigos de mesa representa um potencial risco de aspiração, asfixia, ingestão ou lesões nos dentes caso os cristais se soltem. Para se reduzir este risco, os cristais nunca deverão ser aplicados em quaisquer superfícies de artigos de mesa que possam vir a entrar em contato com alimentos ou com a boca, e os cristais nunca deverão ser aplicados em qualquer artigo de mesa destinado a utilização por parte de crianças. Os artigos de mesa com cristais destinados exclusivamente a fins decorativos, devem ser identificados como tal. Para evitar danos em máquinas de lavar louça, os artigos de mesa decorados com cristais devem ser lavados à mão. As técnicas de aplicação ou as sugestões deste manual não são garantia de que os cristais não se soltem. Para cada aplicação, o fabricante deve determinar se o produto cumpre os requisitos relevantes relativos aos perigos das peças de pequena dimensão ou à utilização em artigos que entrem em contato com alimentos, devendo avaliar quaisquer riscos que possam representar para os usuários.

A utilização de cristais (que podem conter substâncias proibidas, consideradas perigosas de acordo com a legislação local) e de adesivos em artigos de mesa está sujeita a restrições jurídicas em países específicos. O cliente é totalmente responsável por cumprir as disposições específicas do país e deverá defender o bom nome da Swarovski, assim como indenizá-la e protegê-la, em caso de toda e qualquer reivindicação de terceiros baseada na responsabilidade do produto ou de outra forma relacionada com os produtos Swarovski e renuncia todas as reivindicações em nome próprio contra a Swarovski.

Utilizações Inadequadas

Os cristais da Swarovski destinam-se à utilização nos segmentos da moda, joalheria, acessórios, produtos têxteis e decoração de interiores. Devido às suas propriedades físicas, os cristais da Swarovski não se adequam a outras utilizações (por ex., colagem nos dentes, aplicação de cristais perto de ou em membranas mucosas e outras utilizações pouco seguras). O cliente deverá defender o bom nome da Swarovski, assim como indenizá-la e protegê-la, em caso de toda e qualquer reivindicação de terceiros baseada na utilização de produtos Swarovski adquiridos pelo cliente, renunciando todas as suas próprias reivindicações.

Responsabilidade do Usuário

Qualquer aconselhamento oral, escrito ou com base em testes providenciado pela Swarovski relativo a técnicas de aplicação dos seus produtos baseia-se no conhecimento atual da Swarovski e nas informações dos seus fornecedores. Não obstante tais aconselhamentos, o cliente não fica isento de realizar os seus próprios testes em relação às técnicas propostas e à sua adequação para a aplicação desejada. A aplicação, utilização e processamento destas técnicas e produtos são da exclusiva responsabilidade do usuário.

產品全集

施華洛世奇是全球首屈一指的切割水晶製造商，其切割水晶除被廣泛應用於時尚和首飾行業，亦在照明設計、建築和室內設計領域綻放異彩。施華洛世奇水晶已經成為世界各地設計師作品使用的不可或缺的材料。現在，施華洛世奇以施華洛世奇這個品牌名稱向全球的時尚界和設計界提供散裝水晶元素和半製成品。本產品全集提供詳盡的產品資料。而有關的產品資料同時亦被製成數碼版本，及已上載至商務網站 WWW.SWAROVSKI.COM/PROFESSIONAL，並將透過 2014 年 4 月於 iTunes 發佈的全新產品全集 APP (iPad 適用) 以供參閱。

自 1895 年公司成立以來，精益求精和勇於創新的理念是公司的基石。而施華洛世奇追求卓越的精神體現於其致力於時尚潮流研究之中。施華洛世奇不但創造引領時尚的水晶元素，還加入新的顏色和效果，為每年春 / 夏和秋 / 冬時尚兩季增添新元素。這些創新產品及延伸產品均包含在每年二月及九月發佈會的傳訊物料，以及五月季前發佈會的資料之中。作為全球精確切割水晶製造商的翹楚，施華洛世奇為客戶提供多種支持：包括因應不同範疇，為客戶提供特別的產品系列和訂製產品方案；以及時尚潮流支援和應用服務。想獲取更多關於施華洛世奇產品、服務及銷售材料的資訊，請與您就近的施華洛世奇銷售辦事處聯繫。

訂購

如需訂購我們的產品，請與您就近的施華洛世奇銷售辦事處聯繫。此外，已經登記的客戶還可透過 WWW.B2B.ECOMMERCE.SWAROVSKI.COM 的電子商務平台，於網上訂購產品。此網站還提供產品資訊、供貨情況、送貨資料等。請與施華洛世奇銷售辦事處聯繫以取得此項服務。

產品應用資訊

憑藉卓越品質及特別研發的應用技術，施華洛世奇水晶能夠透過輕易及快捷的方法加以應用，實現優質的加工效果。

應用手冊包含了施華洛世奇現有應用技術及技術支援服務的詳細資訊，除了圖文並茂說明正確的焊接、電鍍、黏貼、Ceralun™、縫紉、刺繡、熱熔及機械加工的應用方法外，亦提供實用的護理指引以及所需機器、工具、輔助設備及供應商的相關資訊。手冊提供多種國際語言譯本。

此外，應用手冊的所有詳細及最新資訊亦可從 WWW.SWAROVSKI.COM/PROFESSIONAL 網站取得。網站亦提供應用技術的動畫及影片示範。

欲登入商務網站的內部區域，請與所在地區的施華洛世奇分公司聯繫。

如有關於應用技術的特殊問題，請與所在地區的施華洛世奇銷售辦事處聯繫。

部分切割和未經切割的產品

此產品全集不僅包含切割產品，還包含僅部分切割或未經切割的產品。

/3

水晶未經切割，但有壓製的切割面。



/4

水晶未經切割亦無切割面 (例如產品 2080/4)。

尺寸

水晶可根據不同的量度單位而分類。



PP, SS

圓形水晶可按 PP 總值 (PP)、號數或水晶尺寸 (SS) 量度。請參閱本產品全集最後部份的換算表 (Open to See Sizes)。

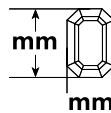

mm

毫米，公制度量單位。

顏色和效果

經典顏色和效果

經典顏色系列提供豐富的顏色選擇，當中包括經典首飾顏色。可使用不同的顏色來配搭成變化多端的組合。

獨有顏色和效果

獨有顏色系列包含時尚潮流的水晶顏色，為施華洛世奇獨家發佈。每一種顏色都是與國際潮流趨勢公司合作的心血結晶，並彰顯出施華洛世奇的高度品質要求與無限創意。獨有顏色和效果以底部劃線的形式顯示於產品列表中。

不同光源下的顏色和效果會有所不同。施華洛世奇使用標準光源 D50 作為決定顏色和比較的準則。

章節的開始部分提供數種產品組別的特殊色卡。

顏色和效果類別

在產品列表中，顏色和效果有特定的分類標準：

水晶
白色 (001), 有鍍底或無鍍底
顏色
素色
可選的素色
蛋白色
可選的蛋白色
混合水晶顏色
可選的混合水晶顏色
陶瓷
可選的陶瓷顏色
顏色
顏色
可選的素色
寶石顏色
可選的寶石顏色
螢光色
可選的螢光色
水晶效果或顏色效果
透明效果
可選的透明效果
金屬效果
可選的金屬效果
全塗層
可選的全塗層效果
水晶銅鏤
可選的水晶銅鏤效果

適用於水晶

適用於水晶珍珠

效果

依塗層的方法而定，在水晶表層進行真空塗層工序能產生特殊的表層效果或半透明效果。

請參閱以下施華洛世奇的效果表列，以及特殊真空塗層工序的說明。

表面效果

(水晶表面上使用真空塗層)



效果編號	名稱
AB	彩白
ANTP	古典粉紅
API	水晶星光粉紅
BLSH	藍色魅影
BRSB	水晶古銅魅影
CAL	銀光
COP	水晶銅
DOR	富麗金
GSHA	金色魅影
HEM	黑礦 (僅適用於黑色水晶)
IRIG	幻彩綠
LISH	淡紫魅影
LUMG	夜光綠色
METBL	水晶金屬藍
MLGLD	水晶金屬淺金
MOL	水晶月光
NUT	古銅黑 (僅適用於黑色水晶)

REDM	水晶紅岩
ROGL	玫瑰金
SAT	銀彩
SSHA	銀色魅影
TRA	透明幻影

半透明效果

(在水晶底部進行真空塗層，可透過半透明水晶元素看到閃爍效果)



效果編號	名稱
BBL	藍光
HEL	紫紅光
MBL	子午藍
SINI	銀色夜影
TAB	啡色光
VL	紫光
VM	七彩
VOL	火山色

銅鏤效果

效果編號	名稱
BLAPA	銅鏤黑
GOLPA	銅鏤金
ROSPA	銅鏤玫紅
SILPA	銅鏤銀
WHIPA	銅鏤白

表層效果的變化



2x
對水晶的兩面進行效果 (例如 AB 2)。



B
在立方體的三面進行效果 (例如 AB B)。



V
把表層效果與半透明效果相反使用。表層效果的真空塗層用於底部，或半透明效果的真空塗層用於表面 (例如，在水晶元素底部用銀色魅影，SSHA V)。



Z
只對水晶的某一部分進行處理，而獲得的效果 (例如 HEL Z)。

FC (全塗層)

經過改良的技術可為珠子系列 (產品 5000) 營造均勻分佈、完美覆蓋的高密度金屬效果。

CAL 'V' SI & CAL 'VZ' SI

對於特定產品 (圓形把手石, 把手石及其他), CAL (銀光) 效果亦會取代標準鍍底 (A、F 等), 被用作水晶底部的鏡面塗層。

/G

產品表面進行局部磨砂 (PF) 或全磨砂 (FF) 處理 (例如產品 2611/G)。

PA (銅鏤效果)

利用創新技術局部進行特別的塗層效果：富歷史感和古舊的外觀，既典雅迷人，又不失水晶光彩。

特殊表層效果

施華洛世奇在水晶表層使用特殊化學與機械工序，造就了各種不同的特殊表層效果。



效果編號

名稱

MAT

磨面加工

COS

迷幻黑色

磨面加工效果以水晶的整個表層進行化學磨面工序所獲得的效果。此化學工序可能會對水晶的尺寸造成細微的差異。透過特殊工序使平底鑽的外層變黑。迷幻黑色效果僅適用於白色 (001)。

鍍底

鍍底是在水晶元素的底部進行鏡面塗層的工序。

**銀色鍍底 (A)**

只適用於施悅™和施亮™熱熔膠產品的銀色鏡面。

**Platinum Pro 專業鍍底 (F)**

以白金色保護層以達至銀色鏡面。Platinum Pro 專業鍍底不但可抵禦來自氯氣、鹽水和香水的環境損害，亦能承受焊接和電鍍等工序，使其具備無與倫比的耐用性。

**鋁質鍍底 (M)**

使用真空塗層工序塗上的鋁質鏡面。

**珠子和吊墜專用保護層 (P)**

保護層是一種塗於效果表面的透明亮漆，用以保護效果免受刮花、指紋和其他損害。當水晶元素並非以底托或鑲嵌件鑲嵌在首飾上時，這保護層亦有助防止濕氣（如汗水）侵蝕效果塗層。

**無鍍底 (U)****熱熔膠技術****熱熔膠 (HF)**

熱熔膠技術包括把特別研發的熱熔膠膠水使用在平底石的底部。此膠水非常有彈性，可在攝氏 120 度下發生作用，並具有在 170 度下發生作用的彈性，亦能與承托物料結合。冷卻過程中，水晶必須永久固定於承托物料上。

透明熱熔膠 (HFT)

此為熱熔膠技術的變體，是一種具備專利的接合劑，可使用於非鏡面塗佈的平底石底部，並能使水晶呈現承托物料之顏色，然後產生饒富趣味的「雨點」效果。

無熱熔膠 (No HF)

採用熱熔膠的產品，亦提供無熱熔膠處理，即不在底部使用熱熔膠水。詳情請與我們的客戶服務部聯繫。

訂製方案

除一般產品系列外，施華洛世奇還提供各種訂製方案*。

可選用的訂製方案如下：

- 採用非標準顏色和效果的標準產品
- 帶圖案 / 印記的標準產品
- 非標準切割和尺寸
- 訂製產品開發
- 特別訂製的半製成品

鑒於各項技術的因素限制，訂製方案或許要求最少訂購量，而常規產品則以獨立包裝形式出售。訂製方案的訂購量可能會出現多供或少供 10% 的情況。如果某種產品的訂單價值低於非標準顏色和效果的標準產品的特定最少量（詳情請參考施華洛世奇價目表），施華洛世奇將加收 20% 的額外費用。請注意，特別製作產品的送貨時間將有別於一般產品。

欲知訂製方案的詳情及建議，請與我們的客戶服務部聯繫。

* 適用於所有顧客。基於技術的可行性和適用的條款及細則，訂製方案的訂購量可能有限制。

法律、規章、規範及標準

進階水晶及以進階水晶標準生產的半製成品之成分，適用於大多數客戶的業務，並符合關於成品中禁用或限制使用特定物質的行業監管規定和法律，包括：

一般安全規定

- 16 CFR 1303 中對於表面塗層的鉛含量的規定

珠寶行業相關規定

- 歐盟 REACH 法規 1907/2006/EG 中對於珠寶的鎳釋放量限制
- 歐盟 REACH 法規 1907/2006/EG 中對於珠寶的鎳含量限制
- 中國行業標準 QB/T2997-2008 中對於貴金屬覆蓋層飾品的規定
- 加州健康和安守則 25214.1 (通稱為加州珠寶法) 修正案 S.B. 646 中對於珠寶和表面塗層的鉛含量限制
- 中國 GB 28480-2012 中對於飾品有害元素限量的規定

兒童 (3-14 歲) 產品安全相關規定

- 116 CFR 1500 (美國消費品安全改進法案, CPSIA), U.S. 74 Fed. Reg. 43031 中對於消費品的鉛含量限制
- 玩具安全指令 2009/48/EU, 附件 II, 第 III.13 節中對於重金屬遷移的限制
- 玩具安全標準 ASTM F963-11 第 4.3.5.2 節中對於重金屬遷移的限制
- 兒童珠寶首飾消費品安全標準規範 ASTM F2923-11
- 通過 H.B. 5040 修訂的伊利諾州 430 ILCS 140 中對於可遷移鎳含量的限制——關於鎳含量的兒童安全法案
- 明尼蘇達州法規 325E.3891 中對於可遷移鎳含量的限制——關於兒童飾品中鎳含量的規定
- 加州健康和安守則 25241.1 修正案 S.B. 929*
- 康涅狄格州法規 21a 第 21a-12d 節——關於兒童產品中鎳含量的規定 *
- 馬利蘭州法規 6-1402——關於兒童飾品中鎳含量的規定 *
- 韓國工業產品的品質管理和安全控制法案 *

電器和電子產品

歐盟 RoHS (指令 2011/65/EC)*、韓國電器 / 電子產品和汽車資源回收法案 * 及日本工業標準 (JIS) * 中對於重金屬含量的限制

包裝

歐洲包裝指令 94/62/EC* 及美國某些州份所採用的包裝材料有毒物質規定 (TPCH) * 中對於重金屬含量的限制

紡織品

除極少數產品外，大多數施華洛世奇水晶均獲得認證，符合 Oeko-Tex Standard 100 的二類標準 (與皮膚有接觸的產品)。此為對無害紡織品的國際品質標籤。若想瞭解有關施華洛世奇水晶符合 Oeko-Tex Standard 100 的更多資訊，請瀏覽 WWW.SWAROVSKI.COM/PROFESSIONAL

* 請注意，以下所述的水晶顏色不符合上述法規：檸檬黃、火紅蛋白、紅鑽石、淺紅、宮廷綠蛋白、紅色及太陽紅。

我們的產品符合上述現行法例 (自 2014 年 3 月起)，但鑒於法例和規定將來可能有更迭，並依不同國家而有所差異，故我們不能保證旗下產品符合所有法規要求。欲瞭解這方面的最新資訊，請瀏覽我們的商務網站。關於協力廠商成品合規性的最終責任，由製成品的生產商一力承擔。

警告標籤**一般警告**

散裝水晶珠可能形狀細小並對兒童有所危險，特別是 3 歲以下的幼兒。根據水晶的大小不同以及任何附著物 (如膠水、纖維等)，兒童可能將水晶哽噎、吸入、吞食或者插入鼻孔，帶有水晶的磁性產品具有特別的風險，一旦被消化有可能帶來嚴重的腸道損傷。本手冊中說明的應用技術並不保證水晶不會散落。對於每種應用，生產商必須確定產品符合關於防範小物件危險的相關要求，並且對它可能對幼兒造成的風險加以評估。如未遵守施華洛世奇的操作指引，可能導致水晶損壞，並因而引起割傷或其他傷害之風險。

有關水晶紋身的警告

水晶紋身僅可使用於健康皮膚，不得黏貼於眼睛或者黏膜部位。不建議兒童使用水晶紋身。散裝水晶珠可能形狀細小並對兒童有所危險，特別是 3 歲以下的幼兒。如果水晶散落，鑒於水晶的大小，兒童可能會將水晶哽噎、吸入、吞食或者插入鼻孔。

餐用具警告

在食具上使用散裝水晶，如果水晶散落，存在被吸入、哽噎、吞食或損傷牙齒的潛在風險。為了降低前述風險，水晶不應被用於可能會接觸到食物或嘴的食具表面，並且不應被用於任何兒童使用的食具上。採用水晶的食具僅為裝飾目的，並應當如此明確標示。為避免損壞洗碗機，飾有水晶的食具必須手洗。本手冊 / 建議中的應用技術並不保證水晶珠不會散落。對於每種應用，生產商必須確定該產品是否符合關於防範小零件危險或在接觸食物的器具上使用的相關要求，並且對它可能對使用者造成的風險加以評估。

在食具上使用水晶 (可能包含當地法律認為有害並限制使用的危險物質) 和黏合劑應依據特定國家的具體法律要求。客戶對於遵循這些國家的具體規定承擔全部責任，並且應對施華洛世奇保護、予以賠償，並確保其免受任何和所有協力廠商基於產品責任而提起的或任何其他與施華洛世奇產品的使用有關的索賠，並放棄其對於施華洛世奇的所有索賠權利。

不當使用

施華洛世奇水晶一般適用於時裝、珠寶、配飾，紡織品和室內裝飾領域。由於其物理特性，施華洛世奇水晶不適用於其他領域 (例如，黏貼於牙齒上、黏膜上或黏膜附近以及其他不安全的使用)。客戶應當保護施華洛世奇免受任何和所有協力廠商基於產品責任或與產品責任相關而提起的索賠之損害，並放棄其自身所有索賠的權利。

使用者責任

我們對於產品應用方法的任何口頭、書面和測試建議均基於我們現有的知識以及供應商提供的資訊而做出。該等建議並不免除客戶對於擬使用的方法以及該方法使用適合擬議中的運用而進行測試的義務。運用、使用和處理該等方法和產品所造成的任何後果應由使用者自行承擔。

产品全集

施华洛世奇是全球首屈一指的切割水晶制造商，其切割水晶除被广泛应用于时尚和首饰行业，亦在照明设计、建筑和室内设计领域绽放异彩。施华洛世奇水晶已经成为世界各地设计师作品使用的不可或缺的材料。现在，施华洛世奇以施华洛世奇这个品牌名称向全球的时尚界和设计界提供散装水晶元素和半制成品。本产品全集提供详尽的产品资料。而有关的产品资料同时亦被制成数码版本，及已上载至商务网站 WWW.SWAROVSKI.COM/PROFESSIONAL，并将通过 2014 年 4 月于 iTunes 发布的全新产品全集 APP (iPad 适用) 以供参阅。

自 1895 年公司成立以来，精益求精和勇于创新的理念是公司的基石。而施华洛世奇追求卓越的精神体现于其致力于时尚潮流研究之中。施华洛世奇不但创造引领时尚的水晶元素，还加入新的颜色和效果，为每年春 / 夏和秋 / 冬时尚两季增添新元素。这些创新产品及延伸产品均包含在每年二月及九月发布会的传讯物料，以及五月季前发布会的资料之中。作为全球精确切割水晶制造商的翘楚，施华洛世奇为客户提供多种支持：包括因应不同范畴，为客户提供特别的产品系列和订制产品方案；以及时尚潮流支持和应用服务。想获取更多关于施华洛世奇产品、服务及销售材料的信息，请与您就近的施华洛世奇销售办事处联系。

订购

如需订购我们的产品，请与您就近的施华洛世奇销售办事处联系。此外，已经登记的客户还可透过 WWW.B2B.ECOMMERCE.SWAROVSKI.COM 的电子商务平台，于网上订购产品。此网站还提供产品信息、供货情况、送货数据等。请与施华洛世奇销售办事处联系以取得此项服务。

产品应用信息

凭借卓越品质及特别研发的应用技术，施华洛世奇水晶能够通过轻易及快捷的方法加以应用，实现优质的加工效果。

应用手册包含了施华洛世奇现有应用技术及技术支持服务的详细信息，除了图文并茂说明正确的焊接、电镀、粘贴、Ceralun™、缝纫、刺绣、热熔及机械加工的应用方法外，亦提供实用的护理指引以及所需机器、工具、辅助设备及供货商的相关信息。手册提供多种国际语言译本。

此外，应用手册的所有详细及最新信息亦可从 WWW.SWAROVSKI.COM/PROFESSIONAL 网站取得。网站亦提供应用技术的动画及影片示范。

欲登入商务网站的内部区域，请与所在地区的施华洛世奇分公司联系。

如有关于应用技术的特殊问题，请与所在地区的施华洛世奇销售办事处联系。

部分切割和未经切割的产品

此产品全集不仅包含切割产品，还包含仅部分切割或未经切割的产品。

/3

水晶未经切割，但有压制的切割面。



/4

水晶未经切割亦无切割面（例如产品 2080/4）。

尺寸

水晶可根据不同的量度单位而分类。



PP, SS

圆形水晶可按 PP 总值 (PP)、号数或水晶尺寸 (SS) 量度。请参阅本产品全集最后部份的换算表 (Open to See Sizes)。

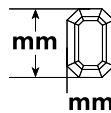

mm

毫米，公制度量单位。

颜色和效果

经典颜色和效果

经典颜色系列提供丰富的颜色选择，当中包括经典首饰颜色。可使用不同的颜色来搭配成变化多端的组合。

独有颜色和效果

独有颜色系列包含时尚潮流的水晶颜色，为施华洛世奇独家发布。每一种颜色都是与国际潮流趋势公司合作的心血结晶，并彰显出施华洛世奇的高度质量要求与无限创意。独有颜色和效果以底部划线的形式显示于产品列表中。

不同光源下的颜色和效果会有所不同。施华洛世奇使用标准光源 D50 作为决定颜色和比较的准则。

章节的开始部分提供数种产品组别的特殊色卡。

颜色和效果类别

在产品列表中，颜色和效果有特定的分类标准：

水晶
白色 (001), 有镀底或无镀底
颜色
素色
可选的素色
蛋白色
可选的蛋白色
混合水晶颜色
可选的混合水晶颜色
陶瓷
可选的陶瓷颜色
颜色
颜色
可选的素色
宝石颜色
可选的宝石颜色
萤光色
可选的萤光色
水晶效果或颜色效果
透明效果
可选的透明效果
金属效果
可选的金属效果
全涂层
可选的全涂层效果
水晶铜锈
可选的水晶铜锈效果

适用于水晶

适用于水晶珍珠

效果

依涂层的方法而定，在水晶表层进行真空涂层工序能产生特殊的表层效果或半透明效果。

请参阅以下施华洛世奇的效果列表，以及特殊真空涂层工序的说明。

表面效果

(水晶表面上使用真空涂层)



效果编号	名称
AB	彩白
ANTP	古典粉红
API	水晶星光粉红
BLSH	蓝色魅影
BRSB	水晶古铜魅影
CAL	银光
COP	水晶铜
DOR	富丽金
GSHA	金色魅影
HEM	黑矿 (仅适用于黑色水晶)
IRIG	幻彩绿
LISH	淡紫魅影
LUMG	夜光绿
METBL	水晶金属蓝
MLGLD	水晶金属浅金
MOL	水晶月光
NUT	古铜黑 (仅适用于黑色水晶)

REDM	水晶红岩
ROGL	玫瑰金
SAT	银彩
SSHA	银色魅影
TRA	透明幻影

半透明效果

(在水晶底部进行真空涂层，可透过半透明水晶元素看到闪烁效果)



效果编号	名称
BBL	蓝光
HEL	紫红光
MBL	子午蓝
SINI	银色夜影
TAB	啡色光
VL	紫光
VM	七彩
VOL	火山色

铜锈效果

效果编号	名称
BLAPA	铜锈黑
GOLPA	铜锈金
ROSPA	铜锈玫红
SILPA	铜锈银
WHIPA	铜锈白

表层效果的变化



2x
对水晶的两面进行效果 (例如 AB 2)。



B
在立方体的三面进行效果 (例如 AB B)。



V
把表层效果与半透明效果相反使用。表层效果的真空涂层用于底部，或半透明效果的真空涂层用于表面 (例如，在水晶元素底部用银色魅影，SSHA V)。



Z
只对水晶的某一部分进行处理，而获得的效果 (例如 HEL Z)。

FC (全涂层)

经过改良的技术可为珠子系列 (产品 5000) 营造均匀分布、完美覆盖的高密度金属效果。

CAL 'V' SI & CAL 'VZ' SI

对于特定产品 (圆形把手石, 把手石及其他), CAL (银光) 效果亦会取代标准镀底 (A、F 等), 被用作水晶底部的镜面涂层。

/G

产品表面进行局部磨砂 (PF) 或全磨砂 (FF) 处理 (例如产品 2611/G)。

PA (铜锈效果)

利用创新技术局部进行特别的涂层效果：富历史感和古旧的外观，既典雅迷人，又不失水晶光彩。

特殊表层效果

施华洛世奇在水晶表层使用特殊化学与机械工序，造就了各种不同的特殊表层效果。

		效果编号	名称
MAT	COS	MAT	磨面加工
		COS	迷幻黑色

磨面加工效果以水晶的整个表层进行化学磨面工序所获得的效果。此化学工序可能会对水晶的尺寸造成细微的差异。通过特殊工序使平底钻的外层变黑。迷幻黑色效果仅适用于白色 (001)。

镀底

镀底是在水晶元素的底部进行镜面涂层的工序。



银色镀底 (A)

只适用于施悦™和施亮™热熔胶产品的银色镜面。



Platinum Pro 专业镀底 (F)

以白金色保护层以达至银色镜面。Platinum Pro 专业镀底不但可抵御来自氯气、盐水和香水的环境损害，亦能承受焊接和电镀等工序，使其具备无与伦比的耐用性。



铝质镀底 (M)

使用真空涂层工序涂上的铝质镜面。



珠子和吊坠专用保护层 (P)

保护层是一种涂于效果表面的透明亮漆，用以保护效果免受刮花、指纹和其他损害。当水晶元素并非以底托或镶嵌件镶嵌在首饰上时，这保护层亦有助防止湿气（如汗水）侵蚀效果涂层。



无镀底 (U)

热熔胶技术

热熔胶 (HF)

热熔胶技术包括把特别研发的热熔胶使用在平底石的底部。此胶水非常有弹性，可在摄氏 120 度下发生作用，并具有在 170 度下发生作用的弹性，亦能与承托物料结合。冷却过程中，水晶必须永久固定于承托物料上。

透明热熔胶 (HFT)

此为热熔胶技术的变体，是一种具备专利的接合剂，可用于非镜面涂布的平底石底部，并能使水晶呈现承托物料之颜色，然后产生饶有趣味的「雨点」效果。

无热熔胶 (No HF)

采用热熔胶的产品，亦提供无热熔胶处理，即不在底部使用热熔胶水。详情请与我们的客户服务部联系。

订制方案

除一般产品系列外，施华洛世奇还提供各种订制方案*。

可选用的订制方案如下：

- 采用非标准颜色和效果的标准产品
- 带图案 / 印记的标准产品
- 非标准切割和尺寸
- 订制产品开发
- 特别订制的半制成品

鉴于各项技术的因素限制，订制方案或许要求最少订购量，而常规产品则以独立包装形式出售。订制方案的订购量可能会出现多供或少供 10% 的情况。如果某种产品的订单价值低于非标准颜色和效果的标准产品的特定最少量（详情请参考施华洛世奇价目表），施华洛世奇将加收 20% 的额外费用。请注意，特别制作产品的送货时间将有别于一般产品。

欲知订制方案的详情及建议，请与我们的客户服务部联系。

* 适用于所有顾客。基于技术的可行性和适用的条款及条件，订制方案的订购量可能有限制。

法律、规章、规范及标准

进阶水晶及以进阶水晶标准生产的半制成品之成分，适用于大多数客户的业务，并符合关于成品中禁用或限制使用特定物质的行业监管规定和法律，包括：

一般安全规定

- 16 CFR 1303 中对于表面涂层的铅含量的规定

珠宝行业相关规定

- 欧盟 REACH 法规 1907/2006/EG 中对于珠宝的镍释放量限制
- 欧盟 REACH 法规 1907/2006/EG 中对于珠宝的镉含量限制
- 中国行业标准 QB/T 2997-2008 中对于贵金属覆盖层饰品的规定
- 加州健康和安守则 25214.1 (通称为加州珠宝法) 修正案 S.B. 646 中对于珠宝和表面涂层的铅含量限制
- 中国 GB 28480-2012 中对于饰品有害元素限量的规定

儿童 (3-14 岁) 产品安全相关规定

- 16 CFR 1500 (美国消费品安全改进法案, CPSIA), U.S. 74 Fed. Reg. 43031 中对于消费品的铅含量限制
- 玩具安全指令 2009/48/EU, 附件 II, 第 III.13 节中对于重金属迁移的限制
- 玩具安全标准 ASTM F963-11 第 4.3.5.2 节中对于重金属迁移的限制
- 儿童珠宝首饰消费品安全标准规范 ASTM F2923-11
- 通过 H.B. 5040 修订的伊利诺伊州 430 ILCS 140 中对于可迁移镉含量的限制——关于镉含量的儿童安全法案
- 明尼苏达州法规 325E.3891 中对于可迁移镉含量的限制——关于儿童饰品中镉含量的规定
- 加州健康和安守则 25241.1 修正案 S.B. 929*
- 康涅狄格州法规 21a 第 21a-12d 节——关于儿童产品中镉含量的规定 *
- 马利兰州法规 6-1402——关于儿童饰品中镉含量的规定 *
- 韩国工业产品的品质管理和安全控制法案 *

电器和电子产品

欧盟 RoHS (指令 2011/65/EC)*、韩国电器 / 电子产品和汽车资源回收法案 * 及日本工业标准 (JIS)* 中对于重金属含量的限制

包装

欧洲包装指令 94/62/EC* 及美国某些州份所采用的包装材料有毒物质规定 (TPCH)* 中对于重金属含量的限制

纺织品

除极少数产品外，大多数施华洛世奇水晶均获得认证，符合 Oeko-Tex Standard 100 的二类标准（与皮肤有接触的产品）。此为对无害纺织品的国际品质标签。若想了解有关施华洛世奇水晶符合 Oeko-Tex Standard 100 的更多信息，请浏览 WWW.SWAROVSKI.COM/PROFESSIONAL

* 请注意，以下所述的仿水晶颜色不符合上述法规：柠檬黄、火红蛋白、红锆石、浅红、宫廷绿蛋白、红色及太阳红。

我们的产品符合上述现行法规（自 2014 年 3 月起），但鉴于法规和规定将来可能有更迭，并依不同国家而有所差异，故我们不能保证旗下产品符合所有法规要求。欲了解这方面的最新信息，请访问我们的商务网站。关于第三方成品合规性的最终责任，由制成品的生产商一力承担。

警告标签**一般警告**

散装仿水晶珠可能形状细小并对儿童有所危险，特别是 3 岁以下的幼儿。根据仿水晶的大小不同以及任何附着物（如胶水、纤维等），儿童可能将仿水晶哽噎、吸入、吞食或者插入鼻孔，带有仿水晶的磁性产品具有特别的风险，一旦被消化有可能带来严重的肠道损伤。本手册中说明的应用技术并不保证仿水晶不会散落。对于每种应用，生产商必须确定产品符合关于防范小物件危险的相关要求，并且对它可能对幼儿造成的风险加以评估。如未遵守施华洛世奇的操作指引，可能导致仿水晶损坏，并因而引起割伤或其他伤害之风险。

有关仿水晶纹身的警告

仿水晶纹身仅可用于健康皮肤，不得粘贴于眼睛或者粘膜部位。不建议儿童使用仿水晶纹身。散装仿水晶珠可能形状细小并对儿童有所危险，特别是 3 岁以下的幼儿。如果仿水晶散落，鉴于仿水晶的大小，儿童可能会将仿水晶哽噎、吸入、吞食或者插入鼻孔。

餐具警告

在餐具上使用散装仿水晶，如果仿水晶散落，存在被吸入、哽噎、吞食或损伤牙齿的潜在风险。为了降低前述风险，仿水晶不应被用于可能会接触到食物或嘴的餐具表面，并且不应被用于任何儿童使用的餐具上。采用仿水晶的餐具仅为装饰目的，并应当如此明确标示。为避免损坏洗碗机，饰有仿水晶的餐具必须手洗。本手册 / 建议中的应用技术并不保证仿水晶珠不会散落。对于每种应用，生产商必须确定该产品是否符合关于防范小零件危险或在接触食物的器具上使用的相关要求，并且对它可能对使用者造成的风险加以评估。

在餐具上使用仿水晶（可能包含当地法律认为有害并限制使用的危险物质）和粘合剂应依据特定国家的具体法律要求。客户对于遵循这些国家的具体规定承担全部责任，并且应对施华洛世奇保护、予以赔偿，并确保其免受任何和所有第三方基于产品责任而提起的或任何其他与施华洛世奇产品的使用有关的索赔，并放弃其对于施华洛世奇的所有索赔权利。

不当使用

施华洛世奇仿水晶一般适用于时装、珠宝、配饰、纺织品和室内装饰领域。由于其物理特性，施华洛世奇仿水晶不适用于其他领域（例如，粘贴于牙齿上、粘膜上或粘膜附近以及其他不安全的使用）。客户应当保护施华洛世奇免受任何和所有第三方基于产品责任或与产品责任相关而提起的索赔之损害，并放弃其自身所有索赔的权利。

使用者责任

我们对于产品应用方法的任何口头、书面和测试建议均基于我们现有的知识以及供应商提供的资讯而做出。该等建议并不免除客户对于拟使用的方法以及该方法使用适合拟议中的运用而进行测试的义务。运用、使用和处理该等方法和产品所造成的任何后果应由使用者自行承担。

COLLECTIONS (コレクション)

Swarovski は、ファッションやジュエリー産業だけでなく、照明器具のデザイン、アーキテクチャー、インテリアの世界でも使用されている、精巧カットクリスタルのリーディングブランドです。Swarovski のクリスタルは世界中のデザイナーにとって創作に欠くことのできない素材となり、Swarovski 社は、ファッション業界やデザイン業界向けのクリスタル・エレメントとエレメントを使用した半完成品を、Swarovski というプロダクトブランドのもとで販売しています。

今回のコレクションは、全ての製品情報をもれなくご紹介しています。また、この製品情報は、弊社ウェブサイトである WWW.SWAROVSKI.COM/PROFESSIONAL からのデジタル・ダウンロードのみならず、2013 年 4 月から iTunes に登場する iPad 向けの新しいコレクション・アプリでもご覧になっていただくことが可能です。1895 年に創立以来、弊社の基本方針として常に革新性や完璧さを追求してまいりました。このような優秀さの追求には、トレンドリサーチに対する Swarovski の取り組みも含まれており、春/夏や秋/冬のファッションシーズン毎に加えられる新しいカラーやエフェクトだけでなく、トレンドに合ったクリスタル・エレメントを発表しています。このような革新的な新色や製品ラインの追加は、毎年 2 月と 9 月に発表される新商品発表のためのコミュニケーション・パッケージと 5 月のプレシーズン新作発表パッケージでご案内しています。精巧カットクリスタルの世界的なリーダーとしての地位を維持するために、Swarovski は、お客様に対するトレンドサポートやアプリケーションサービスのほかに、セグメントにフォーカスしたコレクションやカスタム・プロダクト・ソリューションも承っています。Swarovski の製品、サービス、ツールに関してさらにご質問がございましたら、お近くの Swarovski セールスオフィスまでご連絡ください。

ORDERING (オーダー)

製品のご注文は、お近くの Swarovski セールスオフィスまでご連絡ください。ご登録いただいているお客様は、WWW.B2B.ECOMMERCE.SWAROVSKI.COM の e コマースサービスを使った便利なオンラインオーダーのオプションもございます。このウェブサイトでは、オンラインオーダーの機能に加えて、詳しい製品情報、在庫の有無、納期予定などもご覧になることができます。このようなサービスの登録をご希望の方は、Swarovski セールスオフィスまでご連絡ください。

APPLICATION INFORMATION (アプリケーション)

Swarovski のクリスタルは、卓越したクオリティを誇るのみならず、アプリケーション・テクニックに独自の工夫を重ねているため、素早く簡単に美しく仕上げることができます。

アプリケーション・マニュアルには、最新のものを含め、あらゆるアプリケーション・テクニックに関する詳しい情報や Swarovski 社が提供するテクニカル・サービスの詳細が掲載されています。半田付け、メッキ、接着、Ceralun™、縫付け、刺繍、Hoffix、器具を使用したアプリケーションの正しい装着方法はもちろん、必要な器具・ツール・補助品とその取扱業者に関する情報やお手入れの方法などを、分かりやすいイラストとともに解説します。マニュアルは、さまざまな言語をご用意しています。

アプリケーション・マニュアルに関する詳しい最新情報は、ウェブサイトの WWW.SWAROVSKI.COM/PROFESSIONAL でもご覧いただけます。またアニメーションや動画によるアプリケーション・テクニックのデモンストレーションもご用意しています。ビジネス・ウェブサイト会員エリアへのアクセスをご希望の方は、Swarovski 社担当営業までお問い合わせください。

アプリケーション・テクニックに関する個別のご質問は、お近くの Swarovski セールスオフィスまでご連絡ください。

PART-CUT AND UNCUT ARTICLES

(部分カットおよびカットなし製品)

スタンダードコレクションは、カット製品だけでなく、部分カットやカットのない製品も含まれています。

/3

カットされておらずファセットが型押し加工された製品



/4

クリスタルはカットされておらずファセットもない製品 (例、art. 2080/4)

SIZES (サイズ)

クリスタルストーン サイズ表記には、いくつかの略語が使用されています。



PP, SS

パールプレート (PP)、シーブサイズまたはストーンサイズ (SS) はラウンドクリスタルに対して使われます。本コレクションの最後にあります換算表をご参照ください ("Open to See Sizes")。

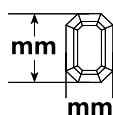

mm

メートル法によるミリメートルで表示されます。

COLORS AND EFFECTS (カラー&エフェクト)

クラシックカラー&エフェクト

クラシックカラーは、基本的なジュエリーカラーをはじめ、幅広い種類のクリスタルカラーを取り揃えています。カラーのクリエイティブな組み合わせにより、オリジナリティだけでなく、豊かなニュアンスも表現することができます。

エクスクルーシブカラー&エフェクト

エクスクルーシブカラーには、Swarovski だけがご提供できる、最新トレンドを反映するクリスタルカラーが含まれています。カラーは一つ一つ、世界的なトレンド機関との協力で開発され、Swarovski の紛れもない特徴である品質と創造性を備えています。エクスクルーシブカラー&エフェクトは、プロダクト・マトリックスで名称にアンダーラインが引かれています。

カラー&エフェクトは、光源の種類により異なって見える場合があります。Swarovski ではカラーの判定及び比較に標準的光源 D50 を使用しています。

それぞれの製品グループの特別なカラーチャートは、各章の始めについています。

Colors and Effects Categories (カラー&エフェクトのカテゴリー)
 プロダクト・マトリックスでは、カラー&エフェクトは体系的に分
 類されています。

クリスタル
クリスタル (001), フォイル付きまたはフォイルなし
カラー
クリスタル・カラー
対応可能なクリスタル・カラー
オパール・カラー
対応可能なオパール・カラー
クリスタル・ブレンド・カラー
対応可能なクリスタル・ブレンド・カラー
セラミック
対応可能なセラミック・カラー
カラー
カラー
対応可能なパール・カラー
ジュムカラー
対応可能なジュムカラー
ネオンカラー
対応可能なネオンカラー
クリスタル・エフェクトまたはカラー・エフェクト
透明エフェクト
対応可能な透明エフェクト
メタリック・エフェクト
対応可能なメタリック・エフェクト
フル・コーティング
対応可能なフル・コーティング・エフェクト
クリスタル・パティナ
対応可能なクリスタル・パティナ

クリスタル用

クリスタル・
パール用

MOL	Moonlight
NUT	Nut (Jetのみ)
REDM	Red Magma
ROGL	Rose Gold
SAT	Satin
SSHA	Silver Shade
TRA	Transmission

裏面エフェクト

(クリスタルの裏側に真空コーティングをするもので、エフェクト
 は透明なクリスタルを通して輝きます)



エフェクトコード	エフェクト名
BBL	Bermuda Blue
HEL	Heliotrope
MBL	Meridian Blue
SINI	Silver Night
TAB	Tabac
VL	Vitrail Light
VM	Vitrail Medium
VOL	Volcano

パティナ・エフェクト

エフェクトコード	エフェクト名
BLAPA	Black Patina
GOLPA	Gold Patina
ROSPA	Rose Patina
SILPA	Silver Patina
WHIPA	White Patina

表面エフェクトのバリエーション



2x
 ストーンの両面をエフェクト処理 (例、AB 2)。



B
 キューブカットの3面だけにエフェクト処理 (AB B)。



V
 通常コーティングする面の反対側に施すエフェクトで
 ず。表面エフェクトを裏面エフェクトのように加工し
 ます (例、SSHA V – Silver Shade を裏面に加工)。



Z
 ストーンの一部のみエフェクト処理 (例、HEL Z)。

FC (フル・コーティング)

技術の向上によって、ビーズ・アソートメント
 (art. 5000) に高輝度メタリック・エフェクトの完全
 に均質な全面コーティングが実現しました。

CAL 'V' SI & CAL 'VZ' SI

特殊なケース (例: Knobs, Handles & Co.) では、標
 準的なフォイル (A, F, ...) のかわりに、クリスタル裏
 面に CAL (Comet Argent Light) エフェクトをミラー・
 コーティングとして使用することも可能です。

/G

部分フロスト加工 (PF) または全面フロスト加工 (FF)
 を施した製品 (例、art. 2611/G)

PA (パティナ)

一部の適合エフェクトを部分的にコーティングする新
 鮮なテクノロジー。「使い古した」アンティーク感に
 よって、クリスタルらしさを失うことなく時代を超え
 た魅力を放ちます。

EFFECTS (エフェクト)

クリスタルの表面に真空コーティングを施すエフェクトには、使用
 するアプリケーションによって、スペシャル表面エフェクトと裏面
 エフェクトがあります。

下記は Swarovski エフェクトのリストとスペシャル真空コーティン
 グ加工の説明です。

表面エフェクト

(クリスタル表面の真空コーティング)



エフェクトコード	エフェクト名
AB	Aurore Boreale
ANTP	Antique Pink
API	Astral Pink
BLSH	Blue Shade
BRSH	Bronze Shade
CAL	Comet Argent Light
COP	Copper
DOR	Dorado
GSHA	Golden Shadow
HEM	Hematite (Jetのみ)
IRIG	Iridescent Green
LISH	Lilac Shadow
LUMG	Luminous Green
METBL	Metallic Blue
MLGLD	Metallic Light Gold

特殊表面エフェクト

Swarovski は、クリスタルの表面に特殊な化学的および機械的加工を施すことにより、各種の特殊表面を可能にしました。



MAT



COS

エフェクトコード

MAT

COS

エフェクト名

Matt Finish

Cosmojet

Matt Finish エフェクトは、クリスタルの全表面に化学的につや消し処理を行うものです。この化学的処理のために、クリスタルのサイズに少々差が生じることがあります。

特殊加工により Flat Back Rose の外側のファセットを黒く加工することができます。Cosmojet エフェクトは Crystal (001) にのみ可能です。

FOILING (フォイル)

フォイルは、クリスタルの裏側にミラーコーティングする加工です。



シルバーフォイル (A)

XIRIUS 及び XILION Hoflix 製品にのみ使われるシルバーミラー仕上げです。



プラチナ・プロ・フォイル (F)

最高品質のプラチナカラーの保護層でコーティングされている、シルバーミラー仕上げです。プラチナ・プロ・フォイルは、塩素、塩水、香水による外的損傷に強いのみならず、はんだ付けや電気めっきにも耐性を発揮するため、これまでにない耐久性を誇ります。



アルミニウムフォイル (M)

真空コーティング加工による、アルミニウムミラー仕上げです。

ビーズ・ペンダント用保護層 (P)

エフェクトの上に塗布する透明ラッカー層です。このラッカーはエフェクトにキズや指紋など損傷が付かないよう保護すると同時に、クリスタル・エレメントにケーシングやセッティングを使用しないジュエリー・デザインの場合にエフェクト層に湿気が浸透して腐食することを防ぐ目的もあります。



フォイルなし (U)

HOTFIX TECHNOLOGY (ホットフィックス)

Hoflix (HF)

Hoflix 技術は、Flat Back の裏面に特別に開発された接着剤を塗布したものです。非常に柔軟性に富むこの接着剤は 120°C で活性化しますが、170°C まで接着可能であり、生地と結合します。クリスタル・エレメントは、冷却過程の間に生地にしっかりと固定されます。

Hoflix トランスペアレント (HFT)

Hoflix テクニックの一種ですが、特許のある結合剤をミラー仕上げのない Flat Backs の裏側に使用するもので、クリスタルが生地のカラーを映し出し、「水滴」のようなおもしろい効果が生じます。

No Hoflix (No HF)

Hoflix 製品は、裏側に接着剤のない Hoflix なし製品としても販売されています。詳しくは弊社カスタマーサービスにお問い合わせください。

CUSTOMIZED SOLUTIONS (カスタム・ソリューション)

スタンダードコレクションのほかに、カスタム・ソリューションが可能です*。

カスタム・ソリューションには以下のオプションがあります。

- スタンダード製品にスタンダード以外のカラーやエフェクトの加工
- スタンダード製品にモチーフ / プリント加工
- スタンダード以外のカットやサイズ
- カスタム製品開発
- エレメントを使用したカスタム半完成品

技術的な理由により、カスタム・ソリューションには最低発注数が設定される場合があります (スタンダード製品は個々のバックでお届けします)。また、カスタム・ソリューションのご注文数は、納品数に ±10% の誤差が出る場合がありますので、予めご容赦ください。スタンダード製品をスタンダード外のカラー&エフェクトでご注文の際、ご注文の額が設定最低額よりも低くなった場合には (詳細は Swarovski 価格表をご覧ください)、20% の追加料金を申し受けます。あらかじめご了承ください。なお、カスタム・ソリューションの納期は個別の設定となっております。

カスタム・ソリューションに関する詳細及びご相談は、弊社カスタマーサービスまでご連絡ください。

* どのお客様でもご利用いただけます。カスタム・ソリューションは、技術的に生産可能と考えられ、また弊社の条件が適用される場合にご利用になれます。

法規制、規準、規格

Advanced Crystal 及び Advanced Crystal スタンダードによる全製品の成分配合は、お客様の主要事業分野での最終製品における一定の物質の使用禁止に関する業界規制規準及び法規制を遵守しています。これには以下のようなものがあります。

一般

- 16 CFR 1303 に規定される表面コーティングの鉛

ジュエリー規制

- 欧州連合 REACH 規制 1907/2006/EG に規定されるジュエリーのニッケル放出量制限
- 欧州連合 REACH 規制 1907/2006/EG に規定されるジュエリーのカドミウム含有量制限
- 中国工業規格 QB/T 2997-2008 貴金属コーティングによる装飾
- カリフォルニア州保健安全法 25214.1 等を修正するカリフォルニア州 S.B. 646 に規定されるジュエリー及び表面コーティングの鉛制限（通称カリフォルニア・ジュエリー法）
- 中国 GB 規格 28480-2012 装飾品 - 有毒物質制限規定

子ども向け製品規制（3～14歳）

- 米国 74 Fed. Reg. 43031 の 16 CFR 1500（米消費者製品安全性改善法、略称 CPSIA）に規定される鉛制限
- 玩具安全性に関する EU 指令 2009/48/EU セクション III.13 アネックスIIの重金属移動制限
- 玩具安全性に関する ASTM F963-11 セクション 4.3.5.2 の重金属移動制限
- ASTM F2923-11 子ども向けジュエリーの消費者製品安全性規格仕様
- イリノイ州 430 ILCS 140 (H.B. 5040 子ども向けカドミウム安全性法により修正) に規定されるカドミウム移動制限
- 子ども向けジュエリーのカドミウム含有に関するミネソタ州法 325E.3891 に規定されるカドミウム移動制限
- カリフォルニア州保健安全法 25241.1 等を修正するカリフォルニア州 S.B. 929*
- 子ども向け製品のカドミウム含有に関するコネチカット州一般法 21a Sec 21a-12d*
- 子ども向けジュエリーのカドミウム含有に関するメリーランド州法 6-1402*
- 工業製品の品質管理及び安全管理に関する韓国法*

電気・電子製品

欧州連合 RoHS（指令 2011/65/EC）*、韓国電気・電子製品及び自動車資源リサイクル法*、日本工業規格（JIS）*

パッケージ

パッケージに関する EU 指令 94/62/EC*、米国の一部の州で採用しているパッケージにおける有害物質に関する規制（TPCH）*

繊維製品

Swarovski のクリスタルはごく少数の例外を除き、繊維製品が無害であることを保証する国際クオリティラベルの Oeko-Tex Standard 100（エコテックス規格 100）第 II 種（肌に直接触れる製品）に準拠しています。Swarovski クリスタルのエコテックス規格 100 第 II 種の遵守状況に関する詳細は、WWW.SWAROVSKI.COM/PROFESSIONAL をご覧ください

* 以下のクリスタル・カラーはこの規制を遵守していません：Citrine、Fireopal、Hyacinth、Light Siam、Palace Green Opal、Siam、Sun。

遵守状況は 2014 年 3 月時点での現行規制に基づく正しい情報ですが、法規制は今後変更される可能性があり、また国によっても異なります。従ってすべての規制を満たしていることを保証するものではありません。遵守状況の最新情報については弊社 B2B ウェブサイトをご覧ください。第三者最終製品の法規制遵守の最終責任は最終製品の製造者にあります。

警告通知

一般警告事項



クリスタルストーンは、幼い子供、特に 3 歳未満の子供にとって、小部品による危害があります。クリスタルのサイズや付帯材料（接着剤や布など）によっては、子供が吸い込んだり、飲み込んだり、のどに詰まらせたり、また鼻に入れたりする可能性があります。クリスタルの付いた磁性製品は、飲み込んだ場合は特に重症の腸障害のリスクがあります。アプリケーションマニュアルに記載されているアプリケーションテクニックは、クリスタルが取れて外れることがないことを保証するものでないことにご注意ください。アプリケーションごとに製造者は、製品が小部品による危害に関連した当該必要事項を満たしているかどうかを見極めて、小さい子供に及ぼすリスクの可能性を評価する必要があります。Swarovski の取扱注意事項に従わない場合は、クリスタルにダメージが生じて、身体に裂傷やその他の危害のリスクが生じる可能性があります。

クリスタルタトゥーに関する警告事項

クリスタルタトゥーは、健康な皮膚にのみ適用することが可能です。目や粘膜には接着しないでください。幼い子供にはクリスタルタトゥーはお薦めておりません。クリスタルストーンは、幼い子供、特に 3 歳未満の子供にとって、小部品による危害があります。もしクリスタルが取れて外れることがある場合は、クリスタルのサイズによっては、子供が吸い込んだり、飲み込んだり、のどに詰まらせたり、また鼻に入れたりする可能性があります。

テーブルウェアに関する警告事項

クリスタルのエレメントを食卓用の食器類に適用する場合は、万が一クリスタルが外れて取れたときに、誤飲、吸引、窒息、歯の損傷のリスクが発生する可能性があります。このようなリスクを軽減するために、口に触れたり、食べ物を入れたりする可能性のある食器の表面には絶対にクリスタルを使用しないでください。また、子供用を目的とする食器にも絶対にクリスタルを装着しないでください。装飾のみを使用目的とするクリスタル付きのテーブルウェアは、その旨を明白にしてください。自動食器洗い機によるダメージを避けるため、クリスタル装飾のあるテーブルウェアは手で洗うようにしてください。アプリケーションマニュアルのアプリケーションテクニックやアイデアは、クリスタルが取れて外れることがないことを保証するものではないことにご注意ください。アプリケーションごとに製造者は、製品が小部品による危害に関連した必要事項、また食品と接する物品に対する使用に関連した必要事項を満たしているかどうかを見極めて、ユーザーに及ぼすリスクを評価する必要があります。

所在国の法律により危険物質とみなされている制限物質を含む可能性のある、クリスタルおよび接着剤をテーブルウェアに使用することは、その国の法的制限の対象となります。お客様は、このような所在国での規定を順守する全責任があり、さらに製品責任を根拠として、または Swarovski 製品の使用に関連して、第三者からいかなる請求が行われても、このような請求に対してお客様は Swarovski 社を擁護し、保護し、損害を与えないものとし、Swarovski 社に対するお客様自身の請求は全て放棄するものとします。

適切でないアプリケーション

Swarovski のクリスタルを使用する目的は、ファッション、ジュエリー、アクセサリ、繊維製品、インテリア装飾の分野です。Swarovski のクリスタルはその物理的性質により、他の用途には適切ではありません（例えば、歯に接着剤でつける、粘膜やその近くでクリスタルを使用する、そのほかの安全でない使用方法）。製品責任を根拠として、またはお客様が購入した Swarovski 製品の使用に関連して、第三者からいかなる請求が行われても、このような請求に対してお客様は Swarovski 社を擁護し、保護し、損害を与えないものとし、Swarovski 社に対するお客様自身の請求は全て放棄するものとします。

ユーザーの義務

製品のアプリケーションテクニックに関する Swarovski の口頭、書面、テストに基づいた助言はどのようなものでも、Swarovski 社の現在の知識およびサプライ業者が提供した情報に基づく、推奨事項です。このような助言は、お客様の使用したいテクニックや意図したアプリケーションの妥当性をお客様がテストすることを、免除するものではありません。テクニックや製品のアプリケーション、使用、加工はユーザーのみの責任となる点にご注意ください。

컬렉션

Swarovski는 패션과 주얼리 분야는 물론 조명 디자인, 건축 및 인테리어에서도 사용되고 있는 정교한 컷 크리스털의 세계적인 제조업체입니다. Swarovski의 크리스털은 국제적으로 디자이너들의 창조 활동에 있어서 필수적인 소재로 여겨져왔으며 패션 및 디자인 업계에 Swarovski 제품 브랜드로 크리스털 원석 및 반제품을 판매하고 있습니다. 이 컬렉션은 모든 제품에 대한 전반적인 개요를 제공하고 있습니다. 전체 제품에 대한 정보는 기업 웹사이트인 WWW.SWAROVSKI.COM/PROFESSIONAL을 통해 디지털 다운로드 가능하며, 2014년 4월 iTunes에서 공개될 새로운 iPad용 컬렉션 앱에서도 확인할 수 있습니다.

설립년도인 1895년 이래로 완벽함과 기술 혁신에 대한 노력은 회사의 기본 정책이 되어 왔습니다. 그 일환으로 Swarovski는 트렌드리서치를 실시하여, 이를 토대로 매년 봄/여름 및 가을/겨울 패션시즌의 트렌드에 맞는 새로운 컬러 및 이펙트를 포함한 크리스털 제품을 생산하고 있습니다. 이러한 신상품과 제품군 추가는 매년 2월과 9월 신상품 관련 종합 판촉물과 5월 프리시즌 판촉물에서 찾아볼 수 있습니다. Swarovski는 정교한 컷 크리스털 제품을 제공하기 위해 최선을 다하는 현존하는 세계적인 선두주자로서 고객들에게 분야별 컬렉션과 맞춤 제품 솔루션, 트렌드 지원 및 어플리케이션 서비스도 제공하고 있습니다. Swarovski의 제품, 서비스 및 영업 자료에 대한 자세한 내용은 Swarovski 현지법인에 문의하십시오.

주문

제품을 주문하려면 가까운 Swarovski 현지법인에 문의하십시오. 등록된 고객은 WWW.B2B.ECOMMERCE.SWAROVSKI.COM의 전자 상거래 서비스를 통해 온라인 주문을 할 수 있습니다. 이 웹사이트에서는 온라인 주문 시스템 제공뿐만 아니라 중요한 제품 정보, 판매 여부, 납품 상세 정보를 확인할 수 있습니다. 이 서비스를 위한 등록은 Swarovski 현지법인으로 문의하십시오.

어플리케이션 정보

Swarovski 크리스털은 뛰어난 품질과 특별히 개발된 어플리케이션 기술을 통해 쉽고 빠르게 고품질의 마감으로 제품에 적용될 수 있습니다.

어플리케이션 매뉴얼에는 Swarovski가 제공하는 현재의 어플리케이션 기술과 기술 관련 서비스에 관한 자세한 정보가 담겨 있습니다. 또한 상세 이미지는 물론, 올바른 납땜 및 도금, 접착, Ceralun™, 바느질, 자수, Hofifix 및 기계적 어플리케이션과 취급에 관한 유용한 설명 및 필요한 기계, 도구 및 보조기구와 그에 대한 설명도 나와 있습니다. 매뉴얼은 다양한 각국의 언어로 제공됩니다.

어플리케이션 매뉴얼에 대한 자세한 최신 정보는 WWW.SWAROVSKI.COM/PROFESSIONAL 웹사이트에서도 확인할 수 있습니다. 또한 이곳에서 어플리케이션 기술을 애니메이션과 동영상으로도 만나실 수 있습니다. 비즈니스 웹사이트의 내부 구역에 접근하시려면 해당 지역 Swarovski 담당자에게 문의해 주십시오.

어플리케이션 기술 관련 문의는 Swarovski 현지법인에서 담당하고 있습니다.

부분컷 및 커팅되지 않은 크리스털

표준 컬렉션에는 컷 크리스털뿐 아니라 부분컷 및 커팅되지 않은 크리스털도 포함되어 있습니다.

/3
크리스털을 커팅하지 않았지만 면이 있음.

/4
크리스털을 커팅하지 않았으며 면도 없음(예: 품목 2080/4).



사이즈

주얼리를 분류하는 데는 다양한 측정 단위가 사용됩니다.



PP, SS
라운드 크리스털의 경우 PP(Pearl Plate), SS(Sieve Size 또는 Stone Size). 컬렉션 뒷부분에 있는 변환표를 참조하십시오(“Open to See Sizes”).

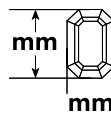

mm
밀리미터 단위의 미터법 치수.

컬러와 이펙트

클래식 컬러와 이펙트

클래식 제품은 모든 클래식 주얼리 컬러를 포함한 다양한 크리스털 컬러를 제공합니다. 이 컬러들의 색채감 있는 조합으로 참신하고 고급스런 분위기를 연출할 수 있습니다.

Swarovski만의 컬러와 이펙트

Swarovski만의 독특한 제품에는 최신 트렌드를 반영하면서 Swarovski만의 크리스털 컬러를 접목했습니다. 국제 트렌드 업체와 협력하여 개발한 각각의 컬러는 Swarovski의 품질과 독창성을 보장합니다. Swarovski만의 컬러와 이펙트는 제품 매트릭스에서 이름 밑에 밑줄을 그어 표시합니다.

컬러와 이펙트는 어떤 빛을 비추는지에 따라 다르게 나타납니다. Swarovski는 컬러 디자인과 비교 시 표준 광원 D50을 이용합니다.

몇 가지 제품 그룹의 특별 컬러 표는 해당 장의 앞부분에 있습니다.

컬러 및 이펙트 분류

제품 매트릭스에서 컬러와 이펙트는 다음과 같이 분류되어 있습니다.

크리스털
크리스털(001), 포일 포함/불포함
컬러
단색
제공되는 단색 컬러
오팔 컬러
제공되는 오팔 컬러
크리스털 블렌드 컬러
제공되는 크리스털 블렌드 컬러
세라믹
제공되는 세라믹 컬러
컬러
컬러
제공되는 단색 컬러
젬컬러
제공되는 젬컬러
네온컬러
제공되는 네온컬러
크리스털 이펙트 또는 컬러 이펙트
투명 이펙트
제공되는 투명 이펙트
메탈릭 이펙트
제공되는 메탈릭 이펙트
전체 코팅
제공되는 전체 코팅 이펙트
크리스털 파티나
제공되는 크리스털 파티나 이펙트

크리스털의 경우

크리스털 필의 경우

MLGLD	Metallic Light Gold
MOL	Moonlight
NUT	Nut (Jet에만 적용)
REDM	Red Magma
ROGL	Rose Gold
SAT	Satin
SSHA	Silver Shade
TRA	Transmission

반투명 이펙트

(크리스털 뒷면의 배큘 코팅 이펙트는 투명 크리스털을 관통하여 반짝입니다)



이펙트 코드	이름
BBL	Bermuda Blue
HEL	Heliotrope
MBL	Meridian Blue
SINI	Silver Night
TAB	Tabac
VL	Vitrail Light
VM	Vitrail Medium
VOL	Volcano

파티나 이펙트

이펙트 코드	이름
BLAPA	Black Patina
GOLPA	Gold Patina
ROSPA	Rose Patina
SILPA	Silver Patina
WHIPA	White Patina

표면 이펙트의 종류



2x
원석의 양면에 이펙트를 준 경우(예: AB 2).



B
육면체의 3면에 이펙트를 준 경우(예: AB B).



V
이 이펙트는 역으로 코팅을 한 경우입니다. 반투명 이펙트를 표면 이펙트로 사용한 경우(예: 크리스털 뒷면에 SSHA V - Silver Shade 코팅 크리스털) 또는 반대의 경우(예: VM V = 크리스털 앞면에 Vitrail Medium 코팅 크리스털)와 같이 사용됩니다.



Z
원석의 일부에만 이펙트를 준 경우(예: HEL Z).

FC(전체 코팅)

향상된 기술로 비드 제품(품목 5000)에 고감도 메탈릭 이펙트를 완벽한 수준으로 균일하게 전체 적용합니다.

CAL`V`SI 및 CAL`VZ`SI

CAL(Comet Argent Light) 이펙트는 특수한 경우(예: Knobs, Handles & Co.) 표준 포일(A, F, ...)을 대신해 크리스털 뒷면 경면 코팅으로 이용되기도 합니다.

/G

부분 불투명 처리(PF) 또는 전체 불투명 처리(FF)된 표면을 가진 품목(예: 품목 2611/G).

PA(파티나)

혁신적 기술을 이용하여 필요한 이펙트를 부분 코팅 적용합니다. 오래 사용한 듯한 모습이 시간을 초월한 매력을 풍기면서도 크리스털의 맑고 깨끗한 느낌은 그대로 유지합니다.

이펙트

크리스털 제품 표면의 배큘 코팅 처리 방법에 따라 특별한 코팅면 또는 반투명한 이펙트를 연출할 수 있습니다.

아래의 모든 Swarovski 이펙트 목록과 특별 배큘 코팅 처리에 대한 설명을 확인하십시오.

표면 이펙트

(크리스털 표면의 배큘 코팅)



이펙트 코드	이름
AB	Aurore Boreale
ANTP	Antique Pink
API	Astral Pink
BLSH	Blue Shade
BRSH	Bronze Shade
CAL	Comet Argent Light
COP	Copper
DOR	Dorado
GSHA	Golden Shadow
HEM	Hematite (Jet에만 적용)
IRIG	Iridescent Green
LISH	Lilac Shadow
LUMG	Luminous Green
METBL	Metallic Blue

특수 표면 이펙트

Swarovski는 크리스털 표면에 특수한 화학적 및 기계적 처리를 통해 다양한 특수 표면 이펙트를 낼 수 있습니다.





		<i>이펙트 코드</i>	<i>이름</i>
MAT	COS	MAT	Matt Finish
		COS	Cosmojet

Matt Finish 이펙트는 크리스털의 전체 표면에 화학적 무광택처리를 하여 얻어집니다. 화학적 처리 과정에서 품목 사이즈에 약간의 변형이 발생할 수 있습니다.

특수 공정을 사용하여 Flat Back Roses의 외부면을 검게 만들 수 있습니다. Cosmojet 이펙트는 크리스털(001) 컬러에만 적용 가능합니다.

포일

포일은 크리스털의 뒷면에 경면 코팅을 하는 것입니다.

-  **실버 포일(A)**
XIRIUS와 XILION Hoflix 제품만을 위한 은경 마감.
-  **플래티늄 프로 포일(F)**
최고 품질 백금 색상의 보호층으로 코팅된 은경 마감. 플래티늄 프로 포일은 염소, 소금물, 향수 등의 환경적 영향에 대한 내구성뿐만 아니라 납땜, 전기도금 등의 가공도 견뎌 탁월한 내구성을 제공합니다.
-  **알루미늄 포일(M)**
배금 코팅 공정을 통한 알루미늄 경면 마감.
-  **비드와 펜던트용 보호층(P)**
보호층은 이펙트 위에 적용되는 투명 래커 시스템입니다. 이 래커는 긁힘, 지문, 기타 손상으로부터 이펙트를 보호하도록 설계되었으며, 또한 크리스털로 디자인된 주얼리가 포장/세팅 안에 들어가지 않게 디자인된 경우 부식을 일으킬 수 있는 습기(특히 땀)가 이펙트 층 아래로 침투하는 것을 방지합니다.
-  **언포일(Unfoiled) (U)**

HOTFIX 기술

Hoflix (HF)

Hoflix 기술은 특별히 개발한 접착제를 Flat Backs의 뒷면에 적용시킨 것입니다. 높은 유연성을 가진 이 접착제는 120°C에서 최고 170°C의 온도 범위에서 활성화되어 부착물에 접착됩니다. 크리스털이 식으면서 접착물에 영구적으로 고정됩니다.

Hoflix트랜스패런트(HFT)

Hoflix기술의 변형으로 경면처리를 하지 않은 Flat Backs의 뒷면에 사용하는 특허 받은 부착 기술이며, 부착물의 컬러가 빛방울이 떨어진 것 같은 흥미로운 효과를 냅니다.

No Hoflix (No HF)

Hoflix 품목은 뒷면에 접착제가 없는 No Hoflix로도 생산됩니다. 보다 자세한 정보를 원하시면 관련 고객 서비스 센터로 문의하여 주십시오.

맞춤 솔루션

표준 컬렉션 이외에도 Swarovski는 맞춤 솔루션을 제공합니다.*

다음과 같은 맞춤 솔루션이 제공 가능합니다.

- 표준 품목에 비표준 컬러 및 이펙트
- 모티브/프린트가 있는 표준 품목
- 비표준 컷 및 사이즈
- 맞춤형 제품 개발
- 맞춤형 반제품

기술적 이유로 맞춤 솔루션에는 최소 주문 수량이 적용될 수 있습니다. 반면에 표준 제품은 팩 단위로 제공될 수 있습니다. 맞춤 솔루션의 주문 수량은 10% 정도 초과 또는 미달될 수 있음에 유의하십시오. 주문 금액이 비표준 컬러와 이펙트를 적용한 표준 품목에 대해 정해진 최소 금액에 미치지 못할 경우 20%의 추가 비용이 발생할 수 있습니다(Swarovski 세부 가격 목록 참조). 맞춤 솔루션의 배송 시기는 각기 다를 수 있음에 유의하십시오.

맞춤 솔루션과 관련한 자세한 내용과 도움말은 해당 고객 서비스에 문의하시기 바랍니다.

* 모든 고객에게 제공되는 것이 원칙이지만, 기술적 실행 가능성에 따라 맞춤 솔루션 제공이 제한될 수 있으며 이용 약관이 적용됩니다.

법률, 규정, 규범 및 표준

Advanced Crystal과 Advanced Crystal 반제품의 성분은 해당 Swarovski 고객 사업 부문의 완제품에 대한 특정 물질 제한 또는 금지에 관하여 다음을 포함한 규제 산업 규범 및 법률을 준수합니다.

일반

- 16 CFR 1303에 명시된 표면 코팅 납 성분

주얼리에 대한 규정

- REACH 규정 1907/2006/EG에 명시된 유럽의 주얼리에 대한 니켈 방출 한도
- REACH 규정 1907/2006/EG에 명시된 유럽의 주얼리에 대한 카드뮴 함량 한도
- 중국산업표준 QB/T 2997-2008 귀금속 코팅 장식품
- 캘리포니아 주 보건 및 안전법 25214.1 이하를 개정한 캘리포니아 주 S.B. 646(통칭 캘리포니아 주얼리법)에 명시된 주얼리 및 표면 코팅의 납 성분 한도
- 중국 GB 28480-2012 장신구에 대한 유해 요소 규정

아동(3-14세) 제품에 대한 규정

- 16 CFR 1500(미국 소비자 안전 개선법, CPSIA), 미국 74 연방 규정 43031에 명시된 납 성분 한도
- 지침 2009/48/EU, 완구류 안전, 부칙 II, III.13항 - 중금속 용출 한도
- ASTM F963-11, 완구류 안전, 4.3.5.2항, 중금속 용출 한도
- ASTM F2923-11 아동 주얼리에 대한 소비자 안전 표준 규정
- 일리노이 주 430 ILCS 140에 명시되고 H.B. 5040 - 카드뮴 안전 아동법에 따라 개정된 카드뮴 용출 한도
- 미네소타 주 법령 325E.3891 - 아동 주얼리의 카드뮴 함량 기준에 명시된 카드뮴 용출 한도
- 캘리포니아 주 보건 및 안전법 25241.1 이하를 개정한 캘리포니아 주 S.B. 929*
- 코네티컷 주 일반 법령 21a, 21a-12d항 - 아동 제품의 카드뮴*
- 메릴랜드 주 법 6-1402 - 아동 주얼리의 카드뮴*
- 한국 품질경영 및 공산품안전관리법*

전기 및 전자 제품

유럽 RoHS(지침 2011/65/EC)*, 한국 전기전자 제품 및 자동차 자원순환법*, 일본 산업 표준(IIS)*에 명시된 중금속 함량 한도

포장

유럽 포장 지침 94/62/EC*에 명시된 중금속 함량 한도 및 미국 일부 주에서 채택한 포장의 독성 물질

섬유 제품

극소수의 예외를 제외하고 Swarovski의 크리스탈은 Oeko-Tex 표준 100 클래스 III(피부에 직접 닿는 제품), 무해 직물에 대한 국제적 품질 라벨 인증을 받았습니다. Oeko-Tex 표준 100을 준수하는 Swarovski 크리스탈에 관한 자세한 내용은 WWW.SWAROVSKI.COM/PROFESSIONAL에서 확인하십시오

* 크리스탈 컬러 시트린, 파이어오팔, 히아신스, 라이트 시암, 펠리스 그린 오팔, 시암, 썬은 위에 표시된 규정을 준수하지 않습니다.

이는 현재 규정(2014년 3월 기준)에 대해 유효하지만 법률 및 규정은 추후에 바뀔 수 있으며 나라마다 다를 수 있다는 점을 고려해야 합니다. 따라서 모든 규정을 따른다고 보증할 수는 없습니다. 업데이트된 정보는 저희 B2B 웹사이트에서 확인하십시오. 타사 완제품의 준수에 대한 최종 책임은 완제품 제조자에게 있습니다.

경고 고지

일반 경고 

날개로 된 크리스탈은 3세 미만의 어린이에게 특히 위험할 수 있는 작은 크기의 형태일 수 있습니다. 크리스탈의 사이즈와 부착 물질(접착제, 섬유 등)에 따라 어린이가 크리스탈을 들이마시거나 삼키거나, 코에 넣을 수 있으며 이로 인해 질식할 수 있습니다. 크리스탈이 사용된 자석 제품은, 삼킬 경우 심각한 내장 손상의 위험이 있을 수 있습니다. 어플리케이션 매뉴얼에 설명되어 있는 어플리케이션 기술은 크리스탈이 빠지지 않는다는 것을 보장하지 않습니다. 각각의 용도에 대해 제조업체는 제품이 소형 물체의 위험과 관련된 요건에 부합하는지 확인하고 어린이에게 발생할 수 있는 위험을 평가해야 합니다. Swarovski의 취급 설명을 따르지 않는 경우 크리스탈이 손상되어 자상이나 기타 해를 입을 위험이 있습니다.

크리스탈 타투에 대한 경고

크리스탈 타투는 건강한 피부에만 사용할 수 있습니다. 눈이나 점막에 부착하지 마십시오. 크리스탈 타투를 어린이에게 사용하는 것은 권장하지 않습니다. 날개로 된 크리스탈은 3세 미만의 어린이에게 특히 위험할 수 있는 작은 크기의 형태일 수 있습니다. 크리스탈의 사이즈에 따라 크리스탈이 날개로 빠지는 경우 어린이가 크리스탈을 들이마시거나 코에 넣을 수도 있으며, 이로 인해 질식할 수 있습니다.

식기류에 대한 경고

식기류에 사용한 크리스탈 날알이 빠지는 경우 흡입하거나 삼키게 될 수 있으며, 질식, 또는 치아 손상 등의 위험이 있습니다. 이러한 위험을 줄이기 위해서는 음식이나 입에 직접 닿을 수 있는 식기류 표면과 어린이용 식기류에 절대로 크리스탈을 사용하지 않는 것이 좋습니다. 장식 용도의 크리스탈이 사용된 식기류는 해당 표시가 되어야 합니다. 식기세척기에 의해 가해지는 손상을 피하기 위해 크리스탈 장식이 된식기류는 손으로 세척하시는 것이 좋습니다. 본 매뉴얼의 어플리케이션 기술 또는 제안은 크리스탈이 빠지지 않는다는 것을 보장하지 않습니다. 식기류 제조업체는 고객에게 발생될 수 있는 작은 부품상의 위험이나 음식이 닿는 제품들의 사용 및 그 외 야기될 수 있는 여러 종류의 위험이 관련된 요건에 부합하는지 확인해야 합니다. 크리스탈(현재 법률에 따라 제한된 위험 물질로 간주되는 물질 포함 가능)의 사용 및 식기류에 대한 크리스탈 부착은 특정 국가의 법적 제한을 받을 수 있습니다. 고객에게는 이러한 국가별 규정을 준수할 전적인 책임이 있으며 제조물 책임법에 기반을 둔 제 3자의 불만 사항이나 Swarovski 제품의 사용과 관련된 배상을 제 3자가 청구할 경우, 고객은 Swarovski를 변호, 면책, 보호하며 책임을 묻지 않습니다.

부적절한 어플리케이션

Swarovski 크리스탈은 패션, 주얼리, 액세서리, 직물 제품, 인테리어 등의 분야에 사용하기 위한 것입니다. 물리적 특성 때문에 Swarovski 크리스탈을 다른 용도로 사용하는 것은 부적절합니다(예: 치아에 접촉, 점막에 또는 그 주변에 크리스탈 사용, 기타 안전하지않은 사용). 고객은 제조물 책임법에 기반을 둔 제 3자의 불만 사항이나 고객이 구입한 Swarovski 제품의 사용과 관련된 배상을 제 3자가청구할 경우 고객은 Swarovski를 변호, 면책, 보호하며 책임을 묻지 않습니다.

사용자의 책임

Swarovski가 제품 사용 기술에 대해 제공한 구두, 서면 또는 테스트 기반의 조언은 Swarovski의 최신 지식과 공급업체가 제공한 정보를 바탕으로 한 권장사항입니다. 그러한 조언에 대해 고객은 원하는 용도에 대한 사용 기술 및 적합성에 대한 테스트를 직접 수행해야 합니다. 이러한 기술 및 제품의 어플리케이션, 사용 및 처리는 사용자의 단독 책임입니다.

КОЛЛЕКЦИИ

Компания Swarovski — ведущий производитель кристаллов высокоточной огранки, используемых не только в индустрии моды и ювелирной промышленности, но и в дизайне осветительных приборов, архитектуре и оформлении интерьеров. Кристаллы от Swarovski стали необходимым материалом в творчестве дизайнеров разных стран. Компания Swarovski предлагает создателям моды и дизайна свои рассыпные кристалльные элементы и передовые интегрированные решения под брендом Swarovski.

Эта Коллекция предоставляет полный обзор ассортимента изделий. Вся информация о продукции доступна также для загрузки в цифровом формате на нашем бизнес-сайте WWW.SWAROVSKI.COM/PROFESSIONAL и в новом приложении Collection App for iPad, которое представлено на iTunes с апреля 2014 года.

Стремление к совершенству и инновациям — это основная опора политики компании с момента ее основания в 1895 г. Настойчивость в завоевании превосходства подразумевает активное использование компанией Swarovski результатов исследований трендов для создания кристалльных элементов, соответствующих модным тенденциям, а также новых цветов и эффектов, которые компания добавляет к ассортименту каждый модный сезон — весна/лето и осень/зима. Инновации и сезонные расширения представлены в полномасштабных коммуникационных пакетах, посвященном выпуску новых коллекций, которые компания ежегодно публикует в феврале и сентябре, и в пакете, предшествующем новому сезону, который выпускается в мае. Стремясь сохранить за собой позиции мирового лидера на рынке точно ограненных кристаллов, компания Swarovski предлагает своим клиентам специальные коллекции для конкретных сегментов и решения для продуктов на заказ, а также содействие в отслеживании трендов и применении продуктов. Для дополнительной информации о продукции Swarovski, услугах и по вопросам о рекламно-информационных материалах обращайтесь, пожалуйста, в ближайший офис продаж компании Swarovski.

ЗАКАЗ

Для заказа кристаллов обратитесь, пожалуйста, в ваш ближайший офис продаж компании Swarovski. Зарегистрированным клиентам предоставлена также удобная возможность онлайн-заказа через службу интернет-продаж: WWW.B2B.ECOMMERCE.SWAROVSKI.COM. На сайте можно не только оформить заказ, но и получить ценную информацию о продукции, ее наличии, условиях доставки и т.д. Для регистрации обратитесь в офис продаж компании Swarovski.

ИНФОРМАЦИЯ ПО ПРИМЕНЕНИЮ КРИСТАЛЛОВ

Благодаря выдающемуся качеству кристаллы Swarovski можно использовать с помощью специально разработанных технологий крепления легко, быстро и на высоком качественном уровне.

«Руководство по применению» содержит подробную информацию обо всех используемых в настоящее время технологиях крепления и технических услугах, предоставляемых компанией Swarovski. В руководство по применению включены подробные иллюстрации и инструкции по правильному выполнению припаивания и гальванизации продуктов, приклеивания, Ceralon™, пришивания, вышивки, крепления Hotfix и механического крепления, а также полезные рекомендации по уходу и информация о необходимых механизмах, инструментах и вспомогательных средствах и об их поставщиках. Руководство по применению издано на различных языках.

Все подробности и обновленная информация о «Руководстве по применению», доступны также на сайте WWW.SWAROVSKI.COM/PROFESSIONAL. Технологии крепления представлены, также, в анимационном формате и как видеоролики. Обратитесь, пожалуйста, в ближайший офис продаж компании Swarovski для получения доступа к внутреннему разделу бизнес-сайта.

Для получения информации по конкретным вопросам технологий применения продуктов обращайтесь, пожалуйста, в ваш местный офис продаж Swarovski.

ЧАСТИЧНО ОГРАНЕННЫЕ И НЕОГРАНЕННЫЕ КРИСТАЛЛЫ

В стандартную коллекцию входят не только ограненные, но также частично ограненные и неограненные кристаллы.

/3

Кристалл не огранен, но имеет прессованный фаcet.



/4

Кристалл не огранен и не имеет фaцета (например, изд. 2080/4).

РАЗМЕРЫ

Для классификации ювелирных камней используют различные сокращения для указания размеров.



PP, SS

Pearl Plate — «плоская жемчужина» — (PP),

Sieve Size — «размер отверстия» или Stone Size

«размер камня» — (SS) для круглых камней. Обратите также внимание на таблицу размеров, приведенную в конце «Коллекции» («Открыть, чтобы увидеть размеры»).

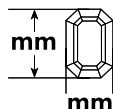

mm

Метрические меры в миллиметрах.

ЦВЕТА И ЭФФЕКТЫ

Классические цвета и эффекты

Классический ассортимент включает в себя широкую палитру цветов кристаллов, в том числе, все классические цвета ювелирных камней. Творческий подход к комбинированию цветов позволит обеспечить не только оригинальные, но и богатые оттенками решения.

Эксклюзивные цвета и эффекты

В эксклюзивный ассортимент включены цвета кристаллов, соответствующие современным трендам. Компания Swarovski является эксклюзивным производителем этой палитры цветов. Каждый цвет, разработанный в сотрудничестве с международными агентствами по изучению и прогнозированию трендов, таит в себе характерный критерий качества и креативности Swarovski. Эксклюзивные цвета и эффекты указаны в продуктовых матрицах в форме подчеркнутых названий.

Цвета и эффекты могут выглядеть по-разному при освещении разными источниками света. Для цветового решения и сравнения Swarovski использует стандартный источник света D50.

Специальные карты цветов для некоторых групп кристаллов размещены в начале соответствующих глав.

Категории цветов и эффектов

В продуктовых матрицах цвета и эффекты соответствуют специальной классификации:

Crystal
Crystal (001), с зеркальным покрытием или без зеркального покрытия
Цвета
Сплошные цвета
Предлагаемые простые цвета
Опаловые цвета
Предлагаемые опаловые цвета
Смешанные кристалльные цвета
Предлагаемые смешанные кристалльные цвета
Керамические
Предлагаемые керамические цвета
Цвета
Цвета
Предлагаемые простые цвета
Цвета драгоценных камней
Предлагаемые цвета драгоценных камней
Неоновые цвета
Предлагаемые неоновые цвета
Эффекты кристалла или цветочные эффекты
Эффекты прозрачности
Предлагаемые эффекты прозрачности
Металлизированные эффекты
Предлагаемые эффекты металлизации
Полное покрытие
Предлагаемые эффекты полного покрытия
Кристалльная патина
Предлагаемые эффекты кристалльной патины

Для кристаллов

Для жемчужин Crystal Pearls

ЭФФЕКТЫ

Нанесение покрытия на поверхность кристаллов методом вакуумного напыления создает как специальные эффекты поверхности, так и эффект полупрозрачности, в зависимости от используемого метода нанесения вакуумного напыления.

Ознакомьтесь, пожалуйста, с представленным ниже списком эффектов Swarovski и описанием специальных процессов вакуумного покрытия.

Эффекты поверхности

(Вакуумное покрытие на поверхности кристалла)



Код эффекта	Название
AB	Aurore Boreale
ANTP	Antique Pink
API	Astral Pink
BLSH	Blue Shade
BRSH	Bronze Shade
CAL	Comet Argent Light
COP	Copper
DOR	Dorado
GSHA	Golden Shadow
HEM	Hematite (только на кристаллах цвета Jet)
IRIG	Iridescent Green
LISH	Lilac Shadow
LUMG	Luminous Green
METBL	Metallic Blue
MLGLD	Metallic Light Gold
MOL	Moonlight
NUT	Nut (только на кристаллах цвета Jet)
REDM	Red Magma
ROGL	Rose Gold
SAT	Satin
SSHA	Silver Shade
TRA	Transmission

Эффекты полупрозрачности

(Вакуумное покрытие на обратной стороне кристалла, эффект просвечивания сквозь прозрачный кристалл)



Код эффекта	Название
BBL	Bermuda Blue
HEL	Heliotrope
MBL	Meridian Blue
SINI	Silver Night
TAB	Tabac
VL	Vitrail Light
VM	Vitrail Medium
VOL	Volcano

Эффекты патины

Код эффекта	Название
BLAPA	Black Patina
GOLPA	Gold Patina
ROSPA	Rose Patina
SILPA	Silver Patina
WHIPA	White Patina

Варианты эффектов поверхности



2x
Эффект наносится на обе стороны кристалла (например, AB 2).



B
Для получения эффекта покрытие наносят на три стороны кристалла кубической формы (например, AB B).



V
Эффект получают в результате нанесения покрытия на обратную сторону. Эффект поверхности используют в качестве просвечивающего эффекта (например, SSHA V – Silver Shade на обратной стороне).

**Z**

Эффект получают благодаря нанесению покрытия лишь на часть камня (например, HEL Z).

FC (Full Coated, полное покрытие)

Благодаря улучшенной технологии обеспечивается идеально равномерное, круговое нанесение высоко интенсивных металлических эффектов для ассортимента бусин (арт. 5000).

CAL 'V' SI И CAL 'VZ' SI

Эффект CAL (Comet Argent Light) будет также использоваться в виде зеркального покрытия на обратной стороне кристалла, заменяя стандартное зеркальное покрытие (A, F, ...) в особых случаях (например, Knobs, Handles & Co.).

/G

Изделие с частично (PF) или полностью матированной (FF) поверхностью (например, изд. 2611/G)

PA (Патина)

Инновационная технология, по которой выполняется частичное нанесение соответствующих эффектов. Легкая патина и нарочито "потертый" вид подчеркивают неподвластность изделий времени при сохранении свойств кристаллов.

Специальные эффекты поверхности

Компания Swarovski смогла разработать различные специальные эффекты поверхности, применяя специальные химические и механические процессы для обработки поверхности кристаллов.



MAT



COS

Код эффекта

MAT

COS

Название

Matt Finish

Cosmojet

Эффект Matt Finish получают благодаря химическому матированию всей поверхности кристалла. Результатом этого химического процесса могут стать незначительные изменения размеров изделий. Использование специального процесса позволяет затемнить внешние грани кристаллов Flat Back Roses. Эффект Cosmojet может применяться только для цвета Crystal (001).

НАНЕСЕНИЕ ЗЕРКАЛЬНОГО ПОКРЫТИЯ

На обратную сторону кристаллов может наноситься отражающее покрытие.

**Silver Foiling (A) — Нанесение зеркально-серебристого покрытия**

Зеркально — серебристое покрытие наносится только на кристаллы XIRIUS и XILION с креплением Hotfix.

**Platinum Pro Foiling (F) — Нанесение платино-образного покрытия**

Зеркально — серебристое покрытие, на которое наносят, окрашенный в цвет платины, защитный слой высочайшего качества. Покрытие Platinum Pro Foiling не только устойчиво к агрессивному воздействию таких элементов внешней среды, как хлор, соль вода и духи, — оно также пригодно для таких процессов, как пайка и гальванопластика, и придает изделию беспрецедентную прочность.

**Aluminum Foiling (M) — Нанесение алюминиево-образного покрытия**

Алюминиево-образное, зеркальное покрытие наносят, используя вакуумную технологию покрытия.

**Protective Layer (P) — Защитный слой для бусин и подвесок**

В качестве защитного слоя используется прозрачная лаковая пленка, которая наносится на покрытие, создающее эффекты поверхности. Лак защищает эффекты от отпечатков пальцев, царапин и других поверхностных повреждений, а также от влаги (в частности, от выделений потовых желез), которая может стать причиной возникновения коррозии и ее проникновения на покрытие, создающие эффекты поверхности в тех случаях, когда ювелирные изделия украшены кристаллами без оправ.

**Unfoiled (U) — Без зеркального покрытия****ТЕХНОЛОГИЯ ГОРЯЧЕЙ ФИКСАЦИИ****Hotfix (HF)**

Технология горячей фиксации Hotfix предполагает нанесение специально разработанного клея на обратную сторону Flat Back — камней с плоским основанием. Чрезвычайно пластичный клей активируется при температуре 120 °C, а его пластичность повышается при нагревании до 170 °C, и он прилипает к поверхности материала. Кристалльный элемент окончательно фиксируется на материале в процессе охлаждения.

Hotfix Transparent (HFT) — Прозрачный Hotfix

В этом варианте технологии Hotfix используют запатентованное связующее вещество, которое наносят на обратную сторону кристаллов с плоским основанием, не имеющих зеркальное покрытие. В результате возникает интересный эффект "дождевой капли" — благодаря которому кристаллы приобретают цвет основы материала.

No Hotfix (No HF) — Технология холодной фиксации No Hotfix

Кристаллы, выполненные по технологии Hotfix, доступны также в варианте No Hotfix, то есть без нанесения клея на обратную сторону. Для получения дополнительной информации обращайтесь, пожалуйста, в офис продаж компании Swarovski.

ПРОДУКЦИЯ НА ЗАКАЗ

Помимо стандартной коллекции, Swarovski предлагает также услуги производства решений по специальному заказу*.

Доступны следующие варианты решений по специальному заказу:

- Стандартные изделия с нестандартными цветами и эффектами
- Стандартные изделия с рисунками/принтами
- Нестандартные огранки и размеры
- Кристаллы, полностью разработанные по индивидуальному заказу
- Передовые интегрированные элементы по индивидуальному заказу

По техническим причинам для продукции, изготавливаемой по специальному заказу, может быть установлен минимальный объем заказа (MOQ), тогда как стандартные изделия поставляются в единичных упаковках. Объем поставляемой специальной продукции может быть на 10% больше или меньше заказанного. Если стоимость одной позиции заказа ниже определенного минимума для стандартных изделий нестандартных цветов и эффектов (подробная информация в прайс-листе Swarovski), на этот артикул будет наложена дополнительная наценка в размере 20% от стоимости. Обратите, пожалуйста, внимание: сроки доставки продукции, выполненной по специальному заказу, устанавливаются индивидуально.

За дополнительной информацией и рекомендациями по решениям, выполняемым по специальному заказу, обращайтесь, пожалуйста, в офис продаж компании Swarovski.

* Могут воспользоваться все наши клиенты. Наличие изделий, изготавливаемых по специальному заказу, может быть ограничено по причинам технической выполнимости или в соответствии с применением наших «Правил и условий».

ЮРИДИЧЕСКИЕ НОРМЫ, ТЕХНИЧЕСКИЕ НОРМЫ, НОРМАТИВЫ И СТАНДАРТЫ

Состав Advanced Crystal и передовых интегрированных решений из Advanced Crystal соответствует регулятивным производственным и правовым нормам применительно к ограничениям или запрету использования определенных веществ в готовых изделиях, устанавливаемых в самых значимых сегментах бизнеса наших клиентов, в том числе:

Общие нормативы

- Содержание свинца в покрытиях поверхности — в соответствии с нормами 16 CFR 1303

Технические нормативы для ювелирных изделий

- Европейские ограничения по выделению никеля для ювелирных изделий — в соответствии с Регламентом ЕС 1907/2006/EG о регистрации, оценке, разрешении и ограничении химических веществ (REACH)
- Европейские ограничения по содержанию кадмия в ювелирных украшениях — в соответствии с Регламентом REACH 1907/2006/EG
- Китайский промышленный стандарт QB/T 2997-2008: Украшения с покрытием из драгоценных металлов
- Ограничения по свинцу в ювелирных изделиях и покрытиях поверхности — в соответствии с нормативом Калифорнии S.B. 646, поправками к Кодексу охраны здоровья и безопасности Калифорнии 25214.1 и посл. (известный под названием Калифорнийского закона о ювелирных украшениях)
- Поправка к китайским нормативам GB 28480-2012 по ювелирным украшениям, регулирующая предельно допустимое содержание вредных элементов

Технические нормы для изделий, предназначенных для детей (3–14 лет)

- Ограничения по свинцу — в соответствии с документом 16 CFR 1500 (Закон США о совершенствовании безопасности потребительских изделий, CPSIA), U.S. 74 Fed. Reg. 43031
- Директива 2009/48/EU, Безопасность игрушек, приложение II, раздел III.13 — предельно допустимое выделение тяжелых металлов
- ASTM F963-11, Безопасность игрушек, раздел 4.3.5.2., предельно допустимая миграция тяжелых металлов
- ASTM F2923-11 Технические требования к безопасности потребительской продукции применительно к детским ювелирным украшениям
- Предельно допустимое выделение кадмия — в соответствии с нормативом Illinois 430 ILCS 140, поправка N.B. 5040 — Закон о запрещении использования кадмия в детских ювелирных изделиях
- Предельно допустимое выделение кадмия — в соответствии с нормативом Minnesota Statutes 325E.3891 — Кадмий в ювелирных изделиях для детей
- California S.B. 929, поправка к Калифорнийскому кодексу охраны здоровья и безопасности 25241.1 и посл.*
- Connecticut Gen. Stat. 21a Sec 21a-12d — Использование кадмия в изделиях для детей*
- Maryland Code 6-1402 — Использование кадмия в ювелирных изделиях для детей*
- Корейский закон об управлении качеством и контроле безопасности промышленной продукции*

Электрические и электронные изделия

Предельно допустимое содержание тяжелых металлов — в соответствии с Европейской директивой об ограничении использования некоторых вредных веществ в электрическом и электронном оборудовании (RoHS) (Директива 2011/65/EC)*, с Законом Кореи об утилизации электрического и электронного оборудования и машин* и с Японским промышленным стандартом (JIS)*

Упаковка

Предельно допустимое содержание тяжелых металлов — в соответствии с Европейской директивой по упаковке 94/62/EC* и нормативными документами, регулирующими содержание токсических веществ в упаковке, действующими в некоторых штатах США (TPCH)*

Изделия из текстиля

Кристаллы Swarovski с самыми незначительными исключениями, сертифицированы в соответствии с классом II стандарта Oeko-Tex Standard 100 (изделия, соприкасающиеся с кожей), который представляет собой международный знак качества, гарантирующий безопасность текстиля. Для получения дополнительной информации по вопросам соответствия конкретным кристаллов Swarovski стандарту Oeko-Tex Standard 100 посетите, пожалуйста, сайт WWW.SWAROVSKI.COM/PROFESSIONAL

* Обратите внимание: кристаллы следующих цветов не соответствуют вышеуказанному нормативу: Citrine, Fireopal, Hyacinth, Light Siam, Palace Green Opal, Siam and Sun.

Вышеуказанное применимо для нормативных документов, действующих на данный момент (март 2014 года), но следует учесть, что законы и регулирующие нормативы в будущем могут измениться, а так же различны в разных странах. Более того, мы не можем гарантировать соответствие всем юридическим и техническим нормам. Для получения обновленной информации просим посетить наш сайт B2B. Окончательную ответственность о соответствии нормативам готовой продукции, выпущенной третьими лицами, несут производители готовой продукции.

ПРЕДУПРЕЖДЕНИЯ



Предупреждения общего характера

Рассыпные кристаллы, как все мелкие предметы, могут представлять угрозу для маленьких детей, особенно для детей, младше трех лет. В зависимости от размера элемента и прикреплённого к нему материала (например, клея, ткани и т.д.), существует опасность того, что ребенок может проглотить кристалл или вставить его в нос; кристалл также может попасть в дыхательные пути ребенка. Магнитные изделия с закрепленными на них кристаллами представляют особую опасность при попадании в желудочно-кишечный тракт. Технологи приложения кристаллов, указанные в «Руководстве по применению», не исключают вероятности отделения кристалла от основы. После каждой аппликации элементов, производитель должен проконтролировать соответствие изделия действующим требованиям безопасности в отношении мелких предметов, и оценить степень его опасности для маленьких детей. Невыполнение рекомендаций компании Swarovski по уходу за ее изделиями, может привести к повреждению кристаллов, что, в свою очередь, способно создать риск пореза или причинения иного вреда.

Предупреждение относительно Crystal Tattoos

Кристалльные татуировки Crystal Tattoos могут быть нанесены только на здоровую кожу. Их нельзя приклеивать к глазам или слизистой оболочке. Не рекомендуется использование кристалльных татуировок для маленьких детей. Рассыпные кристаллы могут представлять собой такую же опасность для маленьких детей, особенно для детей, младше трех лет, как любые мелкие предметы. Если кристалл открепляется, то, в зависимости от размера незакрепленного кристалла, может возникнуть опасность того, что ребенок проглотит кристалл или вставит его в нос, либо кристалл попадет в его дыхательные пути.

Предупреждение по аппликации кристаллов на столовой посуде

Предупреждение по аппликации кристаллов на столовой посуде
Нанесение рассыпных кристаллов на столовую посуду связано с потенциальной опасностью их проглатывания, попадания в дыхательные пути или травмирования зубов, при откреплении кристаллов. Для снижения уровня опасности никогда не следует крепить кристаллы на любые поверхности столовой посуды, которые могут контактировать с пищей или быть использованы для приема пищи, и никогда не следует украшать кристаллами посуду, предназначенную для детей. Столовая посуда с кристаллами, предназначенная только для оформления интерьера, должна иметь соответствующую маркировку. Во избежание повреждения посудомоечной машины, столовую посуду, декорированную кристаллами, следует мыть вручную. Технологии крепления или рекомендации, приведенные в данном «Руководстве по применению» не гарантируют, что кристалл никогда не отделится от носителя. Для каждого случая применения производитель обязан выяснить, соответствует ли изделие действующим требованиям безопасности в отношении мелких предметов или для использования в изделиях, контактирующих с пищевыми продуктами, и оценить степень опасности, которой могут подвергнуться пользователи.

Использование кристаллов (которые могут содержать вещества ограниченного использования, признанные, согласно местным законам, опасными) и клеющих составов для столовой посуды в отдельных странах ограничено правовыми нормами. Клиенты несут полную ответственность за соответствие своей продукции требованиям, действующим в данных странах, и обязаны обеспечить юридическую защиту компании Swarovski, возместить ей убытки и обезопасить ее от возможного ущерба в случае любых претензий третьей стороны, связанных с качеством изделия или с тем или иным использованием продукции Swarovski, и сами не могут предъявлять какие-либо претензии компании Swarovski.

Использование не по назначению

Кристаллы Swarovski предназначены для применения в индустрии моды, ювелирных украшений, аксессуаров, текстильных изделий и для украшения интерьера. По своим физическим свойствам кристаллы Swarovski непригодны для других применений (например, для наклеивания на зубы, нанесение кристаллов на слизистые оболочки или рядом с ними, а также использование в других целях, которые могут повредить здоровью). Клиенты обязаны обеспечить юридическую защиту компании Swarovski, возместить ей убытки и обезопасить ее от возможного ущерба в случае любых претензий третьей стороны, связанных с качеством изделия или с тем или иным использованием продукции Swarovski, и сами не могут предъявлять ей какие-либо претензии.

Ответственность пользователя

Любые устные, письменные или основанные на тестах советы, которые компания Swarovski дает относительно технологий крепления своих изделий, являются рекомендательными и основаны на текущих знаниях компании Swarovski и информации, предоставленной ее поставщиками. Эти советы не избавляют клиента от необходимости самостоятельного тестирования технологий, которые он намерен применять, и их пригодности для предполагаемого применения. Вся ответственность за применение, использование и изменение данных технологий и изделий возлагается исключительно на пользователя.

Designer Editions	01
Round Stones	02
Fancy Stones & Settings	03
Beads	04
BeCharmed & Pavé	05
Crystal Pearls	06
Pendants	07
Flat Backs No Hotfix	08
Flat Backs Hotfix	09
Sew-on Articles	10
Self-adhesive Elements	11
Transfers	12
Synthetics Hotfix	13
Plastic Trimmings	14
Buttons, Fasteners & Zippers	15
Metal Trimmings	16
Crystal Mesh	17
Cupchains & Findings	18
Knobs, Handles & Co.	19

Designer Editions

Swarovski is proud of its long history of creative collaborations with artists, artisans, and designers in all fields of design – a history that continues to be written today by both esteemed established names and new bright young stars. Continually entranced by the myriad possibilities of crystal, these creatives are inspired to transform their sparkling visions into exclusive cuts and designs for Swarovski. Crystal is both the dream-maker and a dynamic source of inspiration for creative minds all over the world.

Designer Editions

SUMMARY

Maison Martin Margiela for Swarovski

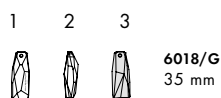
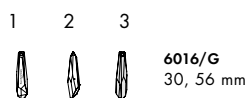

Collection of Keys inspired by Yoko Ono

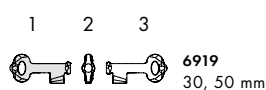
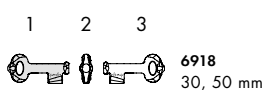

"Love Story of the Heart" by Manish Arora



Diamond Leaf

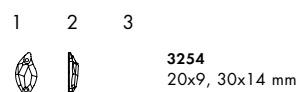
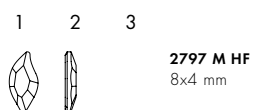

Divine Rock

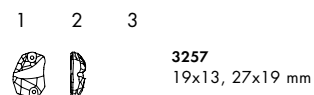

CATALYSING IMAGINATION BY EXCLUSIVE DESIGNER EDITION PRODUCTS

Swarovski can look back with pride on a long history of partnerships with many fashion and design legends like Coco Chanel or Christian Dior. The Aurora Borealis effect, for example, found worldwide acclaim following work with Christian Dior in the 1950s. More recently, the creative partnership with Giorgio Armani saw the development of the Diamond Leaf cut, which features an organic design and closely resembles a natural leaf. Manish Arora created a special collection of heart-shaped crystal pendants for Swarovski. In 2012 a memorable key-shaped crystal pendant was designed for Swarovski, inspired by Yoko Ono. In the last cooperation the “Crystalactite” was developed together with renowned Parisian design house Maison Martin Margiela. This innovative precision-cut crystal component draws its inspiration directly from nature, with “Crystalactite” reflecting the origin of iconic stalactite shapes. These design co-operations are joyful collaborations that always result in beauty and quite unconventional displays of creativity.

Dior, Maison Martin Margiela and Yoko Ono are just three examples of the many celebrated designers/artists who have worked with Swarovski over the years, turning loose crystals into limitless creative possibilities.

DESIGNER EDITIONS – DISTINCT PACKAGING

All products except Maison Martin Margiela Designer Edition will be labelled with the “Designer Edition” imprint directly on the packaging. The Maison Martin Margiela Designer Edition will be labelled with the “Maison Martin Margiela for Swarovski” imprint.

MAISON MARTIN MARGIELA FOR SWAROVSKI

Crystalactite Pendants

Since 1988, Paris-based Maison Martin Margiela has become famous for its collaborative team-led approach and its avant-garde transformation of classic designs. In July 2013, it presented the *Maison Martin Margiela Crystalactite for Swarovski* at its Paris Haute Couture show. These were groundbreaking Crystal Fusion components inspired by natural stalactite forms and developed in creative partnership with Swarovski. Now Swarovski presents its interpretation of this innovative cut in pure crystal – the *Crystalactite Pendant*. Featuring a progressive aesthetic combining partly frosted facets with primeval, irregular icicle shapes, the vision that originated in our wildest landscapes has now been perfected by one of the most sophisticated design houses. Together with an easy-to-apply hole at the top, the Grand and Petite Pendants offer myriad design possibilities for strong, contemporary designs, and for recreating haute-couture looks.

“Naturally and spontaneously, an imposing crystal emerges from its raw, stony origin, patiently growing into its iconic stalactite shape.”

6016/G The Grand Crystalactite partly frosted



Crystal		
Crystal (001)	<input type="checkbox"/>	<input type="checkbox"/>
Colors		
Plain Colors		
Jet (280)	<input type="checkbox"/>	<input type="checkbox"/>
Crystal Effects		
Transparent Effects		
Crystal AB V (001 AB V)	<input type="checkbox"/>	<input type="checkbox"/>
Crystal Antique Pink V (001 ANTP V)	<input type="checkbox"/>	<input type="checkbox"/>
Crystal Bermuda Blue P (001 BBL)*	<input type="checkbox"/>	<input type="checkbox"/>
Crystal Blue Shade V (001 BLSH V)	<input type="checkbox"/>	<input type="checkbox"/>
Crystal Bronze Shade V (001 BRSH V)	<input type="checkbox"/>	<input type="checkbox"/>
Crystal Copper V (001 COP V)	<input type="checkbox"/>	<input type="checkbox"/>
Crystal Golden Shadow V (001 GSHA V)	<input type="checkbox"/>	<input type="checkbox"/>
Crystal Silver Night (001 SINI)	<input type="checkbox"/>	<input type="checkbox"/>
Crystal Silver Shade V (001 SSHA V)	<input type="checkbox"/>	<input type="checkbox"/>
Crystal Vitrail Light P (001 VL)*	<input type="checkbox"/>	<input type="checkbox"/>
Crystal Vitrail Medium P (001 VM)*	<input type="checkbox"/>	<input type="checkbox"/>
Metallic Effects		
Crystal Comet Argent Light V P (001 CAL V)*	<input type="checkbox"/>	<input type="checkbox"/>

6017/G Crystalactite Pendant grand partly frosted



Crystal		
Crystal (001)	<input type="checkbox"/>	<input type="checkbox"/>
Colors		
Plain Colors		
Jet (280)	<input type="checkbox"/>	<input type="checkbox"/>
Crystal Effects		
Transparent Effects		
Crystal AB V (001 AB V)	<input type="checkbox"/>	<input type="checkbox"/>
Crystal Antique Pink V (001 ANTP V)	<input type="checkbox"/>	<input type="checkbox"/>
Crystal Bermuda Blue P (001 BBL)*	<input type="checkbox"/>	<input type="checkbox"/>
Crystal Blue Shade V (001 BLSH V)	<input type="checkbox"/>	<input type="checkbox"/>
Crystal Bronze Shade V (001 BRSH V)	<input type="checkbox"/>	<input type="checkbox"/>
Crystal Copper V (001 COP V)	<input type="checkbox"/>	<input type="checkbox"/>
Crystal Golden Shadow V (001 GSHA V)	<input type="checkbox"/>	<input type="checkbox"/>
Crystal Silver Night (001 SINI)	<input type="checkbox"/>	<input type="checkbox"/>
Crystal Silver Shade V (001 SSHA V)	<input type="checkbox"/>	<input type="checkbox"/>
Crystal Vitrail Light P (001 VL)*	<input type="checkbox"/>	<input type="checkbox"/>
Crystal Vitrail Medium P (001 VM)*	<input type="checkbox"/>	<input type="checkbox"/>
Metallic Effects		
Crystal Comet Argent Light V P (001 CAL V)*	<input type="checkbox"/>	<input type="checkbox"/>

* For details about the “protective layer” please refer to page 24.

6018/G The Petite Crystalactite partly frosted



- Crystal**
- Crystal (001)
- Colors**
- Plain Colors**
- Jet (280)
- Crystal Effects**
- Transparent Effects**
- Crystal AB V (001 AB V)
- Crystal Antique Pink V (001 ANTP V)
- Crystal Bermuda Blue P (001 BBL)*
- Crystal Blue Shade V (001 BLSH V)
- Crystal Bronze Shade V (001 BRSH V)
- Crystal Copper V (001 COP V)
- Crystal Golden Shadow V (001 GSHA V)
- Crystal Silver Night (001 SINI)
- Crystal Silver Shade V (001 SSHA V)
- Crystal Vitrail Light P (001 VL)*
- Crystal Vitrail Medium P (001 VM)*
- Metallic Effects**
- Crystal Comet Argent Light V P (001 CAL V)*

6019/G Crystalactite Pendant petite partly frosted



- Crystal**
- Crystal (001)
- Colors**
- Plain Colors**
- Jet (280)
- Crystal Effects**
- Transparent Effects**
- Crystal AB V (001 AB V)
- Crystal Antique Pink V (001 ANTP V)
- Crystal Bermuda Blue P (001 BBL)*
- Crystal Blue Shade V (001 BLSH V)
- Crystal Bronze Shade V (001 BRSH V)
- Crystal Copper V (001 COP V)
- Crystal Golden Shadow V (001 GSHA V)
- Crystal Silver Night (001 SINI)
- Crystal Silver Shade V (001 SSHA V)
- Crystal Vitrail Light P (001 VL)*
- Crystal Vitrail Medium P (001 VM)*
- Metallic Effects**
- Crystal Comet Argent Light V P (001 CAL V)*

* For details about the "protective layer" please refer to page 24.

YOKO ONO

Yoko Ono is a multi-media artist whose thought provoking work challenges people's understanding of art and the world around them.

Her work as a conceptualist has encompassed performance, instructions, film, music, writing, and now jewelry inspiration for Swarovski.

Born in Tokyo in 1933, she moved to New York in 1953, where she became part of the city's vibrant avant-garde scene. She went on to perform and exhibit what have now become legendary works in the history of contemporary art, including her famous 1969 collaboration, *Bed-In*, with husband John Lennon.

She has had numerous exhibitions in museums, and in 2009, received the Golden Lion for Lifetime Achievement from the Venice Biennale. In 2011 Ono was honored with the prestigious 8th Hiroshima Art Prize for her dedicated peace activism, and in 2012 received the Oskar Kokoschka Prize in Vienna.

THE COOPERATION

A memorable key-shaped crystal pendant, inspired by Yoko Ono, has been designed for Swarovski. The design itself is a technical masterwork and tells us a wonderful story around the symbol key. It is available in two different versions: with and without the signature of Yoko Ono.

THE STORY

**"Imagine a key that unlocks the door to the forest with its secrets,
to the sky with its peacefulness,
to the universe with its infinity,
to a future with the promise of a better life."**

Yoko Ono

This concept by Yoko Ono has been created as a crystal "KEY TO OPEN THE FOREST" exclusively for our Swarovski collection. It embodies the spirits of earth and sky, and reflects the multiple colors of nature. "Make a promise to a tree. Ask it to be passed on to other trees." When you wear it you will be sharing Yoko's dream of peaceful interaction with the world around you. "Whisper your dream to a cloud. Ask the cloud to remember it." A memorable key-shaped crystal pendant, inspired by Yoko Ono, has been designed for Swarovski. The design itself is a technical masterwork and tells us a wonderful story around the symbol key. It is available in two different versions: with and without the signature of Yoko Ono.

6918 Key to Open the Forest*



- Crystal**
- Crystal (001)
- Colors**
- Plain Colors**
- Indian Sapphire (217)
- Crystal Effects**
- Transparent Effects**
- Crystal Blue Shade (001 BLSH)
- Crystal Bronze Shade (001 BRSH)
- Crystal Copper (001 COP)
- Crystal Golden Shadow (001 GSHA)
- Crystal Silver Night (001 SINI)
- Crystal Silver Shade (001 SSHA)

6919 Key Pendant

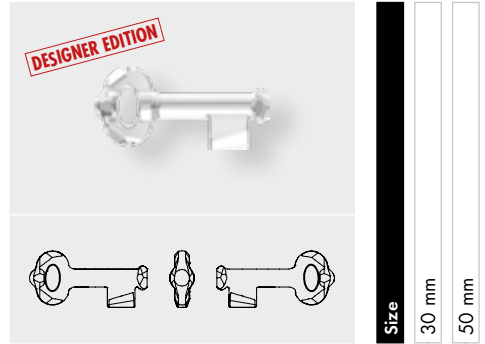

- Crystal**
- Crystal (001)
- Colors**
- Plain Colors**
- Indian Sapphire (217)
- Crystal Effects**
- Transparent Effects**
- Crystal AB (001 AB)
- Crystal Blue Shade (001 BLSH)
- Crystal Bronze Shade (001 BRSH)
- Crystal Copper (001 COP)
- Crystal Golden Shadow (001 GSHA)
- Crystal Silver Night (001 SINI)
- Crystal Silver Shade (001 SSHA)
- Metallic Effects**
- Crystal Iridescent Green (001 IRIG)

* Please note, that this article is only available until August 2015.

“LOVE STORY OF THE HEART” BY MANISH ARORA

Since the beginning of his international career, the award winning, Delhi-based designer Manish Arora has worked creatively with Swarovski. In 2009, he created a memorable collection of crystalline Transfers. One year later, India’s best loved and most prolific design talent renewed his partnership with Swarovski and created a special collection of heart-shaped crystal pendants, which were launched in February 2011. Each individual piece is an expression of love’s different emotional state and is named accordingly.

The partnership with Manish Arora is symbolic of how Swarovski engages in mutually rewarding creative partnerships with the world’s best and brightest design spirits.

“The heart shape is very close to me because it is the universal symbol of love. I wanted to bring this symbol to life by creating a collection of crystal pendants and I hope people will wear them as a personal expression of the beauty and purity of this emotion,” Manish Arora

6260 Crazy 4 U Heart

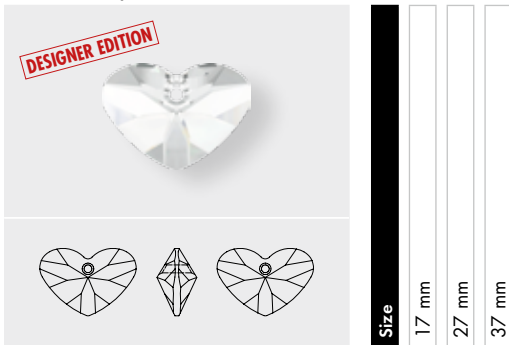

- Crystal**
- Crystal (001)
- Crystal Effects**
- Transparent Effects**
- Crystal AB (001 AB)
- Crystal Antique Pink (001 ANTP)
- Crystal Astral Pink (001 API)
- Crystal Golden Shadow (001 GSHA)
- Crystal Satin (001 SAT)

6261 Devoted 2 U Heart

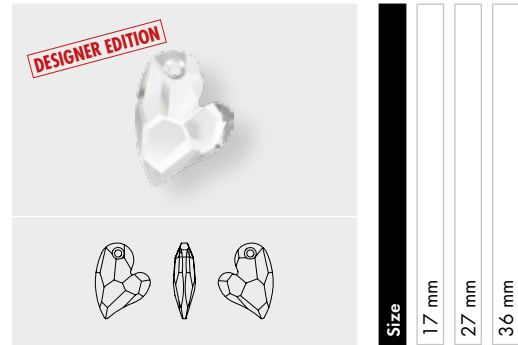

- Crystal**
- Crystal (001)
- Colors**
- Plain Colors**
- Amethyst (204)
- Aquamarine (202)
- Jet (280)
- Rosaline (508)
- Crystal Effects**
- Transparent Effects**
- Crystal AB (001 AB)
- Crystal Antique Pink (001 ANTP)
- Crystal Astral Pink (001 API)
- Crystal Bermuda Blue P (001 BBL)*
- Crystal Blue Shade (001 BLSH)
- Crystal Golden Shadow (001 GSHA)
- Crystal Lilac Shadow (001 LISH)
- Crystal Red Magma (001 REDM)
- Crystal Satin (001 SAT)
- Crystal Vitrail Medium P (001 VM)*
- Metallic Effects**
- Crystal Comet Argent Light V P (001 CAL V)*

* For details about the “protective layer” please refer to page 24.

6262 Miss U Heart

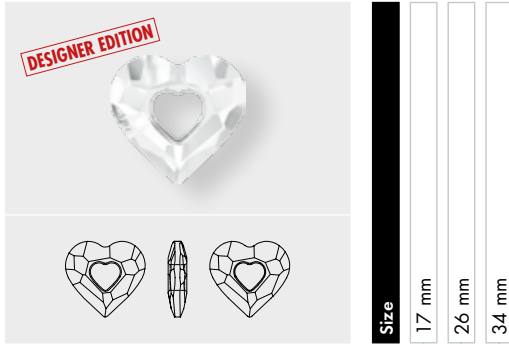

Crystal	17 mm	26 mm	34 mm
Crystal (001)	■	■	■
Colors			
Plain Colors			
Amethyst (204)	■		
Crystal Effects			
Transparent Effects			
Crystal AB (001 AB)	■	■	■
Crystal Antique Pink (001 ANTP)	■	■	■
Crystal Astral Pink (001 API)	■	■	■
Crystal Golden Shadow (001 GSHA)	■	■	■
Crystal Lilac Shadow (001 LISH)	■	■	■
Crystal Satin (001 SAT)	■	■	■

6264 Truly in Love Heart

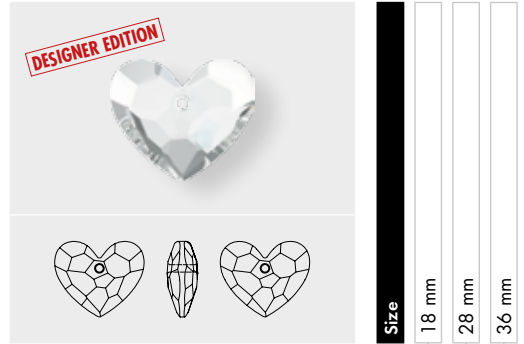

Crystal	18 mm	28 mm	36 mm
Crystal (001)	■	■	■
Crystal Effects			
Transparent Effects			
Crystal AB (001 AB)	■	■	■
Crystal Antique Pink (001 ANTP)	■	■	■
Crystal Astral Pink (001 API)	■	■	■
Crystal Bermuda Blue P (001 BBL)*	■	■	■
Crystal Golden Shadow (001 GSHA)	■	■	■
Crystal Lilac Shadow (001 LISH)	■	■	■
Crystal Red Magma (001 REDM)	■	■	■
Crystal Satin (001 SAT)	■	■	■

* For details about the “protective layer” please refer to page 24.

DIAMOND LEAF

Swarovski and Giorgio Armani worked together to create an exclusive crystal called "Diamond Leaf". This Designer Edition has a fluid, organic shape reminiscent of a leaf. Precision cut facets melt into the softness of a floating, sculptural form, contrasting strength and fragility, the timeless with the ethereal.

Giorgio Armani: "Swarovski crystal brings a touch of magic to a dress, an ethereal quality, a lustre which never fails to captivate the attention."

2797 Diamond Leaf Flat Back No Hotfix



Size
8x4 mm
10x5 mm

Crystal
Crystal F (001)

Crystal Effect

Transparent Effects
Crystal AB F (001 AB)

2797 Diamond Leaf Flat Back Hotfix



Size
8x4 mm

Crystal
Crystal M HF (001)

Crystal Effect

Transparent Effects
Crystal AB M HF (001 AB)

3254 Diamond Leaf Sew-on Stone



Size
20x9 mm
30x14 mm

Crystal
Crystal F (001)

Colors
Plain Colors
Jet (280)

Crystal Effects
Transparent Effects
Crystal Golden Shadow F (001 GSHA)
Crystal Silver Shade F (001 SSAH)

DIVINE ROCK

This exclusive cut is the result of Swarovski’s creative cooperation with leading international designers that present a quite unique look. The crystal features an exciting contrast between sparkling facets and other facets with a matt finish. An optimal brilliance and superb light refraction is achieved thanks to the use of an irregular and deep layered cutting technology, which is yet another example of the innovative power invested in producing cutting edge Swarovski.

3257 Divine Rock Sew-on Stone

DESIGNER EDITION

Crystal

Crystal F (001)

Size

19x13 mm

27x19 mm

Designer Editions

PRODUCT DETAILS

Article Size	Packing Unit = Minimum Order Quantity in Pieces	Average Net Weight in Gram per Packing Unit Crystal (001)	Average Gross Weight in Gram per Packing Unit Crystal (001)
2797			
8x4 mm	240	14.9	24.0
10x15 mm	180	23.4	32.6
2797 M HF			
8x4 mm	240	14.9	24.0
3254			
20x9 mm	72	60.3	87.8
30x14 mm	36	100.6	129.6
3257			
19x13 mm	96	58.3	76.3
27x19 mm	30	132.2	152.0
6016/G			
30 mm	12	20.160	45.612
56 mm	6	67.536	91.392
6017/G			
30 mm	12	24.968	45.612
56 mm	6	67.536	91.392
6018/G			
35 mm	8	52.416	74.592
6019/G			
35 mm	8	52.416	74.592
6260			
17 mm	48	56.25	81.93
27 mm	20	88.72	111.92
37 mm	6	60.26	88.96
6261			
17 mm	48	48.21	76.63
27 mm	20	77.00	102.60
36 mm	12	112.49	135.29
6262			
17 mm	48	67.90	91.90
26 mm	16	74.02	92.48
34 mm	6	53.74	80.33
6918			
30 mm	36	63.806	88.633
50 mm	6	43.596	66.493
6919			
30 mm	36	63.806	88.633
50 mm	6	43.596	66.493

Round Stones

Round Stones are loose crystal elements. Most of them are pointed on the reverse side, making them easy to apply in either metal claw settings or pre-set cavities in die-cast metal alloys. The assortment features a wide variety of different cuts, the most innovative one is the XIRIUS Chaton.

The science of the cut and the celebration of crystal as high art come together in the XIRIUS Chaton, Swarovski's most brilliant crystal element ever.

The merging of a gemstone-like cut with rich, varied color and Platinum Pro foiling for exceptional durability, XIRIUS takes crystal one step closer to the diamond.

COLORS & EFFECTS

Colors

-  Crystal 001
-  White Opal 234
-  Light Silk 261
-  Silk 391
-  Light Peach 362
-  Rosaline 508
-  Rose Water Opal 395
-  Vintage Rose 319
-  Light Rose 223
-  Rose Peach 262
-  Padparadscha 542
-  Indian Pink 289
-  Hyacinth 236
-  Light Siam 227
-  Indian Siam*** 327
-  Rose 209
-  Fuchsia 502
-  Ruby 501
-  Siam 208
-  Burgundy 515
-  Garnet 241
-  Amethyst 204
-  Cyclamen Opal 398
-  Purple Velvet 277
-  Tanzanite 539
-  Violet 371
-  Light Amethyst 212
-  Provence Lavender 283

-  Light Sapphire 211
-  Light Azure 361
-  Aquamarine 202
-  Air Blue Opal 285
-  Sapphire 206
-  Capri Blue 243
-  Dark Indigo 288
-  Montana 207
-  Turquoise 267
-  Caribbean Blue Opal 394
-  Light Turquoise 263
-  Blue Zircon 229
-  Indicolite 379
-  Indian Sapphire 217
-  Denim Blue 266
-  Black Diamond 215
-  Pacific Opal 390
-  Chrysolite Opal 294
-  Chrysolite 238
-  Peridot 214
-  Erinite 360
-  Fern Green 291
-  Dark Moss Green 260
-  Emerald 205
-  Palace Green Opal 393
-  Olivine 228
-  Khaki 550
-  Greige 284
-  Light Grey Opal 383

-  Sand Opal 287
-  Light Colorado Topaz 246
-  Jonquil 213
-  Light Topaz 226
-  Sunflower 292
-  Topaz 203
-  Tangerine 259
-  Light Smoked Topaz 221
-  Smoked Topaz 220
-  Smoky Quartz 225
-  Jet 280

Ceramics

-  Marbled Light Grey 657
-  Marbled Terracotta 655
-  Marbled Yellow 652
-  Marbled Blue 654
-  Marbled Black 653

Effects

-  Crystal Silver Shade 001 SSHA
-  Crystal Moonlight 001 MOL
-  Crystal Aurore Boreale 001 AB
-  Crystal Luminous Green* 001 LUMG
-  Crystal Golden Shadow 001 GSHA
-  Crystal Rose Gold 001 ROGL
-  Crystal Copper* 001 COP
-  Crystal Astral Pink 001 API
-  Crystal Red Magma* 001 REDM

-  Crystal Antique Pink* 001 ANTP
-  Crystal Vitrail Light** 001 VL
-  Crystal Vitrail Medium** 001 VM
-  Crystal Volcano** 001 VOL
-  Crystal Lilac Shadow 001 LISH
-  Crystal Heliotrope** 001 HEL
-  Crystal Bermuda Blue** 001 BBL
-  Crystal Metallic Blue* 001 METBL
-  Crystal Blue Shade* 001 BLSH
-  Crystal Tabac** 001 TAB
-  Crystal Iridescent Green 001 IRIG
-  Crystal Dorado* 001 DOR

-  Crystal Metallic Light Gold* 001 MLGLD
-  Crystal Bronze Shade* 001 BRSH
-  Crystal Satin* 001 SAT
-  Crystal Comet Argent Light* 001 CAL
-  Crystal Silver Night** 001 SINI
-  Jet Nut* 280 NUT
-  Jet Hematite* 280 HEM

Crystal Patina

-  Crystal White Patina 001 WHIPA
-  Crystal Rose Patina 001 ROSPA
-  Crystal Silver Patina 001 SILPA
-  Crystal Gold Patina 001 GOLPA
-  Crystal Black Patina 001 BLAPA

Numerical Order

001	Crystal	001 TAB	Crystal Tabac**	234	White Opal	327	Indian Siam***
001 AB	Crystal Aurore Boreale	001 VL	Crystal Vitrail Light**	236	Hyacinth	360	Erinite
001 ANTP	Crystal Antique Pink**	001 VM	Crystal Vitrail Medium**	238	Chrysolite	361	Light Azore
001 API	Crystal Astral Pink	001 VOL	Crystal Volcano**	241	Garnet	362	Light Peach
001 BBL	Crystal Bermuda Blue**	001 WHIPA	Crystal White Patina	243	Capri Blue	371	Violet
001 BLAPA	Crystal Black Patina	202	Aquamarine	246	Light Colorado Topaz	379	Indicolite
001 BLSH	Crystal Blue Shade*	203	Topaz	259	Tangerine	383	Light Grey Opal
001 BRSH	Crystal Bronze Shade*	204	Amethyst	260	Dark Moss Green	390	Pacific Opal
001 CAL	Crystal Comet Argent Light*	205	Emerald	261	Light Silk	391	Silk
001 COP	Crystal Copper*	206	Sapphire	262	Rose Peach	393	Palace Green Opal
001 DOR	Crystal Dorado*	207	Montana	263	Light Turquoise	394	Caribbean Blue Opal
001 GOLPA	Crystal Gold Patina	208	Siam	266	Denim Blue	395	Rose Water Opal
001 GSHA	Crystal Golden Shadow	209	Rose	267	Turquoise	398	Cyclamen Opal
001 HEL	Crystal Heliotrope**	211	Light Sapphire	277	Purple Velvet	501	Ruby
001 IRIG	Crystal Iridescent Green	212	Light Amethyst	280	Jet	502	Fuchsia
001 LISH	Crystal Lilac Shadow	213	Jonquil	280 HEM	Jet Hematite*	508	Rosaline
001 LUMG	Crystal Luminous Green*	214	Peridot	280 NUT	Jet Nut*	515	Burgundy
001 METBL	Crystal Metallic Blue*	215	Black Diamond	283	Provence Lavender	539	Tanzanite
001 MLGLD	Crystal Metallic Light Gold*	217	Indian Sapphire	284	Greige	542	Padparadscha
001 MOL	Crystal Moonlight	220	Smoked Topaz	285	Air Blue Opal	550	Khaki
001 REM	Crystal Red Magma*	221	Light Smoked Topaz	287	Sand Opal	652	Marbled Yellow
001 ROGL	Crystal Rose Gold	223	Light Rose	288	Dark Indigo	653	Marbled Black
001 ROSPA	Crystal Rose Patina	225	Smoky Quartz	289	Indian Pink	654	Marbled Blue
001 SAT	Crystal Satin*	226	Light Topaz	291	Fern Green	655	Marbled Terracotta
001 SINI	Crystal Silver Night**	227	Light Siam	292	Sunflower	657	Marbled Light Grey
001 SILPA	Crystal Silver Patina	228	Olivine	294	Chrysolite Opal		
001 SSHA	Crystal Silver Shade	229	Blue Zircon	319	Vintage Rose		

Alphabetical Order

Air Blue Opal (285)	Crystal Metallic Blue* (001 METBL)	Indian Sapphire (217)	Pacific Opal (390)
Amethyst (204)	Crystal Metallic Light Gold* (001 MLGLD)	Indian Siam*** (327)	Padparadscha (542)
Aquamarine (202)	Crystal Moonlight (001 MOL)	Indicolite (379)	Palace Green Opal (393)
Black Diamond (215)	Crystal Red Magma* (001 REDM)	Jet (280)	Peridot (214)
Blue Zircon (229)	Crystal Rose Gold (001 ROGL)	Jet Hematite* (280 HEM)	Provence Lavender (283)
Burgundy (515)	Crystal Rose Patina (001 ROSPA)	Jet Nut* (280 NUT)	Purple Velvet (277)
Capri Blue (243)	Crystal Satin* (001 SAT)	Jonquil (213)	Rosaline (508)
Caribbean Blue Opal (394)	Crystal Silver Night** (001 SINI)	Khaki (550)	Rose (209)
Chrysolite (238)	Crystal Silver Patina (001 SILPA)	Light Amethyst (212)	Rose Peach (262)
Chrysolite Opal (294)	Crystal Silver Shade (001 SSHA)	Light Azore (361)	Rose Water Opal (395)
Crystal (001)	Crystal Tabac** (001 TAB)	Light Colorado Topaz (246)	Ruby (501)
Crystal Antique Pink* (001 ANTP)	Crystal Vitrail Light** (001 VL)	Light Grey Opal (383)	Sand Opal (287)
Crystal Astral Pink (001 API)	Crystal Vitrail Medium** (001 VM)	Light Peach (362)	Sapphire (206)
Crystal Aurore Boreale (001 AB)	Crystal Volcano** (001 VOL)	Light Rose (223)	Siam (208)
Crystal Bermuda Blue** (001 BBL)	Crystal White Patina (001 WHIPA)	Light Sapphire (211)	Silk (391)
Crystal Black Patina (001 BLAPA)	Cyclamen Opal (398)	Light Siam (227)	Smoked Topaz (220)
Crystal Blue Shade (001 BLSH)	Dark Indigo (288)	Light Silk (261)	Smoky Quartz (225)
Crystal Bronze Shade* (001 BRSH)	Dark Moss Green (260)	Light Smoked Topaz (221)	Sunflower (292)
Crystal Comet Argent Light* (001 CAL)	Denim Blue (266)	Light Topaz (226)	Tangerine (259)
Crystal Copper* (001 COP)	Emerald (205)	Light Turquoise (263)	Tanzanite (539)
Crystal Dorado* (001 DOR)	Erinite (360)	Marbled Black (653)	Topaz (203)
Crystal Gold Patina (001 GOLPA)	Fern Green (291)	Marbled Blue (654)	Turquoise (267)
Crystal Golden Shadow (001 GSHA)	Fuchsia (502)	Marbled Light Grey (657)	Vintage Rose (319)
Crystal Heliotrope** (001 HEL)	Garnet (241)	Marbled Terracotta (655)	Violet (371)
Crystal Iridescent Green (001 IRIG)	Greige (284)	Marbled Yellow (652)	White Opal (234)
Crystal Lilac Shadow (001 LISH)	Hyacinth (236)	Montana (207)	
Crystal Luminous Green* (001 LUMG)	Indian Pink (289)	Olivine (228)	

This color chart is valid for the product groups Round Stones and Fancy Stones.

The displayed assortment is not entirely available for all products within the product groups. For details on available colors and effects, please see the product matrix for the respective item.

Classic Colors: This color range offers a wide choice of traditional Swarovski crystal colors.
Exclusive Colors: This color range is offered exclusively by Swarovski.

The standard assortment of colors and effects may vary per product group.

Slight changes in shades are unavoidable. Colors may vary according to cut and shape.

The plating resistance of effects is tested according to Swarovski's plating guidelines (WWW.SWAROVSKI.COM/PROFESSIONAL). Customers are advised to carry out their own tests if customers' plating parameters diverge from Swarovski plating guidelines.

* Crystals are not resistant to plating and similar processing.

** Crystals are resistant to plating only if they are foiled.

*** The color Indian Siam is available only for a specific size range. Please refer to the current Collection.

Round Stones

SUMMARY

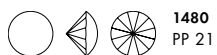
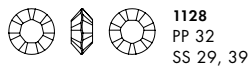
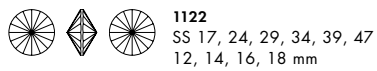
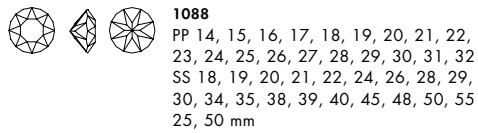
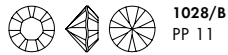
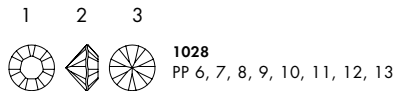

1 Top view 2 Side view 3 Back view
• The logo position is marked with a red dot.

Round Stones

1028 XILION Chaton



Size	PP 6	PP 7	PP 8	PP 9	PP 10	PP 11	PP 12	PP 13
------	------	------	------	------	-------	-------	-------	-------

Crystal

- Crystal (001)
- Crystal F (001)

Colors

Plain Colors

- Amethyst F (204)
- Aquamarine F (202)
- Black Diamond F (215)
- Blue Zircon F (229)
- Burgundy F (515)
- Capri Blue F (243)
- Chrysolite F (238)
- Dark Indigo F (288)
- Dark Moss Green F (260)
- Denim Blue F (266)
- Emerald F (205)
- Erinite F (360)
- Fern Green F (291)
- Fuchsia F (502)
- Garnet F (241)
- Greige F (284)
- Hyacinth F (236)
- Indian Pink F (289)
- Indian Sapphire F (217)
- Indian Siam F (327)
- Indicolite F (379)
- Jet (280)
- Jet F (280)
- Jonquil F (213)
- Khaki F (550)
- Light Amethyst F (212)
- Light Azore F (361)
- Light Colorado Topaz F (246)
- Light Peach F (362)
- Light Rose F (223)
- Light Sapphire F (211)
- Light Siam F (227)
- Light Silk F (261)
- Light Smoked Topaz F (221)
- Light Topaz F (226)

Round Stones

1028		Size	PP 6	PP 7	PP 8	PP 9	PP 10	PP 11	PP 12	PP 13
Light Turquoise F (263)						■	■	■		■
Montana F (207)		■	■	■	■	■	■	■	■	■
Padparadscha F (542)					■	■	■	■		■
Peridot F (214)		■	■	■	■	■	■	■	■	■
Purple Velvet F (277)					■	■	■	■		■
Rose F (209)		■	■	■	■	■	■	■	■	■
Ruby F (501)					■	■	■	■	■	■
Sapphire F (206)		■	■	■	■	■	■	■	■	■
Siam F (208)		■	■	■	■	■	■	■	■	■
Silk F (391)					■	■	■	■		■
Smoked Topaz F (220)		■	■	■	■	■	■	■		■
Smoky Quartz F (225)					■	■	■	■		■
Tangerine F (259)					■	■	■	■		■
Tanzanite F (539)		■	■	■	■	■	■	■	■	■
Topaz F (203)		■	■	■	■	■	■	■	■	■
Turquoise (267)					■	■	■	■		■
Vintage Rose F (319)		■			■	■	■	■		■
Violet F (371)		■	■	■	■	■	■	■	■	■
Opal Colors										
Air Blue Opal F (285)					■	■	■	■		■
Caribbean Blue Opal F (394)					■	■	■	■		■
Cyclamen Opal F (398)					■	■	■	■		■
Light Grey Opal F (383)					■	■	■	■		■
Pacific Opal F (390)					■	■	■	■		■
Palace Green Opal F (393)					■	■	■	■		■
Rose Water Opal F (395)								■		■
White Opal F (234)					■	■	■	■		■
Crystal Effects										
Transparent Effects										
Crystal AB F (001 AB)		■	■	■	■	■	■	■	■	■
Crystal Antique Pink F (001 ANTP)					■	■	■	■		■
Crystal Blue Shade F (001 BLSH)					■	■	■	■		■
Crystal Bronze Shade F (001 BRSH)					■	■	■	■		■
Crystal Golden Shadow F (001 GSHA)					■	■	■	■		■
Crystal Lilac Shadow F (001 LISH)					■	■	■	■		■
Crystal Luminous Green F (001 LUMG)					■	■	■	■		■
Crystal Moonlight F (001 MOL)					■	■	■	■		■
Crystal Silver Night F (001 SINI)		■			■	■	■	■		■
Crystal Silver Shade F (001 SSHA)					■	■	■	■		■

Round Stones

1028

Size

Metallic Effects

- Crystal Dorado F (001 DOR)
- Crystal Iridescent Green F (001 IRIG)
- Crystal Metallic Blue F (001 METBL)
- Crystal Metallic Light Gold F (001 MLGLD)
- Crystal Rose Gold F (001 ROGL)

Color Effects

Metallic Effects

- Jet Hematite (280 HEM)

1028/B XILION Chaton

Size

Colors

Ceramics

- Marbled Black (653)
- Marbled Blue (654)
- Marbled Light Grey (657)
- Marbled Terracotta (655)
- Marbled Yellow (652)

Round Stones

1088 XIRIUS Chaton

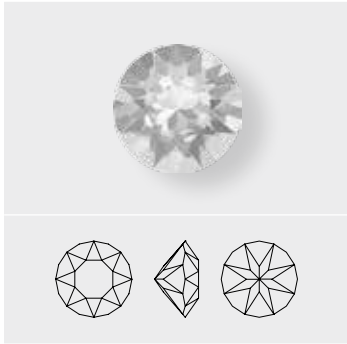

Crystal

- Crystal (001)
- Crystal F (001)

Colors

Plain Colors

- Amethyst F (204)
- Aquamarine F (202)
- Black Diamond F (215)
- Blue Zircon F (229)
- Burgundy F (515)
- Capri Blue F (243)
- Chrysolite F (238)
- Dark Moss Green F (260)
- Denim Blue F (266)
- Emerald F (205)
- Erinite F (360)
- Fern Green F (291)
- Fuchsia F (502)
- Garnet F (241)
- Greige F (284)
- Hyacinth F (236)
- Indian Pink F (289)
- Indian Sapphire F (217)
- Indicolite F (379)
- Jet (280)
- Jet F (280)
- Jonquil F (213)
- Khaki F (550)
- Light Amethyst F (212)
- Light Azure F (361)
- Light Colorado Topaz F (246)
- Light Peach F (362)
- Light Rose F (223)
- Light Sapphire F (211)
- Light Siam F (227)
- Light Silk F (261)
- Light Smoked Topaz F (221)
- Light Topaz F (226)
- Light Turquoise F (263)
- Montana F (207)
- Padparadscha F (542)

Size	PP 14	PP 15	PP 16	PP 17	PP 18	PP 19	PP 20	PP 21	PP 22	PP 23	PP 24	PP 25	PP 26	PP 27	PP 28	PP 29	PP 30	PP 31	PP 32
Crystal (001)																			
Crystal F (001)																			
Amethyst F (204)																			
Aquamarine F (202)																			
Black Diamond F (215)																			
Blue Zircon F (229)																			
Burgundy F (515)																			
Capri Blue F (243)																			
Chrysolite F (238)																			
Dark Moss Green F (260)																			
Denim Blue F (266)																			
Emerald F (205)																			
Erinite F (360)																			
Fern Green F (291)																			
Fuchsia F (502)																			
Garnet F (241)																			
Greige F (284)																			
Hyacinth F (236)																			
Indian Pink F (289)																			
Indian Sapphire F (217)																			
Indicolite F (379)																			
Jet (280)																			
Jet F (280)																			
Jonquil F (213)																			
Khaki F (550)																			
Light Amethyst F (212)																			
Light Azure F (361)																			
Light Colorado Topaz F (246)																			
Light Peach F (362)																			
Light Rose F (223)																			
Light Sapphire F (211)																			
Light Siam F (227)																			
Light Silk F (261)																			
Light Smoked Topaz F (221)																			
Light Topaz F (226)																			
Light Turquoise F (263)																			
Montana F (207)																			
Padparadscha F (542)																			

Round Stones

02 Round Stones







































1088		Size																		
		PP 14	PP 15	PP 16	PP 17	PP 18	PP 19	PP 20	PP 21	PP 22	PP 23	PP 24	PP 25	PP 26	PP 27	PP 28	PP 29	PP 30	PP 31	PP 32
	Peridot F (214)	■	■	■	■	■	■	■	■	■	■	■	■	■	■	■	■	■	■	■
	Provence Lavender F (283)	■	■	■	■	■	■	■	■	■	■	■	■	■	■	■	■	■	■	■
	Purple Velvet F (277)	■	■	■	■	■	■	■	■	■	■	■	■	■	■	■	■	■	■	■
	Rose F (209)	■	■	■	■	■	■	■	■	■	■	■	■	■	■	■	■	■	■	■
	Rose Peach F (262)	■	■	■	■	■	■	■	■	■	■	■	■	■	■	■	■	■	■	■
	Ruby F (501)	■	■	■	■	■	■	■	■	■	■	■	■	■	■	■	■	■	■	■
	Sapphire F (206)	■	■	■	■	■	■	■	■	■	■	■	■	■	■	■	■	■	■	■
	Siam F (208)	■	■	■	■	■	■	■	■	■	■	■	■	■	■	■	■	■	■	■
	Silk F (391)	■	■	■	■	■	■	■	■	■	■	■	■	■	■	■	■	■	■	■
	Smoked Topaz F (220)	■	■	■	■	■	■	■	■	■	■	■	■	■	■	■	■	■	■	■
	Smoky Quartz F (225)	■	■	■	■	■	■	■	■	■	■	■	■	■	■	■	■	■	■	■
	Sunflower F (292)	■	■	■	■	■	■	■	■	■	■	■	■	■	■	■	■	■	■	■
	Tangerine F (259)	■	■	■	■	■	■	■	■	■	■	■	■	■	■	■	■	■	■	■
	Tanzanite F (539)	■	■	■	■	■	■	■	■	■	■	■	■	■	■	■	■	■	■	■
	Topaz F (203)	■	■	■	■	■	■	■	■	■	■	■	■	■	■	■	■	■	■	■
	Turquoise (267)	■	■	■	■	■	■	■	■	■	■	■	■	■	■	■	■	■	■	■
	Vintage Rose F (319)	■	■	■	■	■	■	■	■	■	■	■	■	■	■	■	■	■	■	■
	Violet F (371)	■	■	■	■	■	■	■	■	■	■	■	■	■	■	■	■	■	■	■
Opal Colors																				
	Air Blue Opal F (285)	■	■	■	■	■	■	■	■	■	■	■	■	■	■	■	■	■	■	■
	Caribbean Blue Opal F (394)	■	■	■	■	■	■	■	■	■	■	■	■	■	■	■	■	■	■	■
	Cyclamen Opal F (398)	■	■	■	■	■	■	■	■	■	■	■	■	■	■	■	■	■	■	■
	Light Grey Opal F (383)	■	■	■	■	■	■	■	■	■	■	■	■	■	■	■	■	■	■	■
	Pacific Opal F (390)	■	■	■	■	■	■	■	■	■	■	■	■	■	■	■	■	■	■	■
	Palace Green Opal F (393)	■	■	■	■	■	■	■	■	■	■	■	■	■	■	■	■	■	■	■
	Rose Water Opal F (395)	■	■	■	■	■	■	■	■	■	■	■	■	■	■	■	■	■	■	■
	Sand Opal F (287)	■	■	■	■	■	■	■	■	■	■	■	■	■	■	■	■	■	■	■
	White Opal F (234)	■	■	■	■	■	■	■	■	■	■	■	■	■	■	■	■	■	■	■
Crystal Effects																				
Transparent Effects																				
	Crystal AB F (001 AB)	■	■	■	■	■	■	■	■	■	■	■	■	■	■	■	■	■	■	■
	Crystal Antique Pink F (001 ANTP)	■	■	■	■	■	■	■	■	■	■	■	■	■	■	■	■	■	■	■
	Crystal Blue Shade F (001 BLSH)	■	■	■	■	■	■	■	■	■	■	■	■	■	■	■	■	■	■	■
	Crystal Bronze Shade F (001 BRSH)	■	■	■	■	■	■	■	■	■	■	■	■	■	■	■	■	■	■	■
	Crystal Golden Shadow F (001 GSHA)	■	■	■	■	■	■	■	■	■	■	■	■	■	■	■	■	■	■	■
	Crystal Lilac Shadow F (001 LISH)	■	■	■	■	■	■	■	■	■	■	■	■	■	■	■	■	■	■	■
	Crystal Luminous Green F (001 LUMG)	■	■	■	■	■	■	■	■	■	■	■	■	■	■	■	■	■	■	■
	Crystal Moonlight F (001 MOL)	■	■	■	■	■	■	■	■	■	■	■	■	■	■	■	■	■	■	■
	Crystal Silver Night F (001 SINI)	■	■	■	■	■	■	■	■	■	■	■	■	■	■	■	■	■	■	■
	Crystal Silver Shade F (001 SSHA)	■	■	■	■	■	■	■	■	■	■	■	■	■	■	■	■	■	■	■

Round Stones

1088		Size	PP 14	PP 15	PP 16	PP 17	PP 18	PP 19	PP 20	PP 21	PP 22	PP 23	PP 24	PP 25	PP 26	PP 27	PP 28	PP 29	PP 30	PP 31	PP 32
Metallic Effects																					
	Crystal Dorado F (001 DOR)		■				■			■			■							■	■
	Crystal Iridescent Green F (001 IRIG)		■				■			■			■							■	■
	Crystal Metallic Blue F (001 METBL)		■				■			■			■							■	■
	Crystal Metallic Light Gold F (001 MLGLD)		■				■			■			■							■	■
	Crystal Rose Gold F (001 ROGL)		■				■			■			■							■	■
Crystal Patina																					
	Crystal Black Patina F (001 BLAPA)												■								■
	Crystal Gold Patina F (001 GOLPA)												■								■
	Crystal Rose Patina F (001 ROSPA)												■								■
	Crystal Silver Patina F (001 SILPA)												■								■
	Crystal White Patina F (001 WHIPA)												■								■
Color Effects																					
Metallic Effects																					
	Jet Hematite (280 HEM)		■				■			■			■							■	■

Round Stones

02 Round Stones

1088																									
		Size	SS 18	SS 19	SS 20	SS 21	SS 22	SS 24	SS 26	SS 28	SS 29	SS 30	SS 34	SS 35	SS 38	SS 39	SS 40	SS 45	SS 48	SS 50	SS 55	25 mm	50 mm		
Crystal																									
 Crystal (001)																									
 Crystal F (001)																									
Colors																									
Plain Colors																									
 Amethyst F (204)																									
 Aquamarine F (202)																									
 Black Diamond F (215)																									
 Blue Zircon F (229)																									
 Burgundy F (515)																									
 Capri Blue F (243)																									
 Chrysolite F (238)																									
 Dark Moss Green F (260)																									
 Denim Blue F (266)																									
 Emerald F (205)																									
 Erinite F (360)																									
 Fern Green F (291)																									
 Fuchsia F (502)																									
 Garnet F (241)																									
 Greige F (284)																									
 Hyacinth F (236)																									
 Indian Pink F (289)																									
 Indian Sapphire F (217)																									
 Indicolite F (379)																									
 Jet (280)																									
 Jonquil F (213)																									
 Khaki F (550)																									
 Light Amethyst F (212)																									
 Light Azore F (361)																									
 Light Colorado Topaz F (246)																									
 Light Peach F (362)																									
 Light Rose F (223)																									
 Light Sapphire F (211)																									
 Light Siam F (227)																									
 Light Silk F (261)																									
 Light Smoked Topaz F (221)																									
 Light Topaz F (226)																									
 Light Turquoise F (263)																									
 Montana F (207)																									
 Padparadscha F (542)																									
 Peridot F (214)																									

Round Stones

1088		Size																					
		SS 18	SS 19	SS 20	SS 21	SS 22	SS 24	SS 26	SS 28	SS 29	SS 30	SS 34	SS 35	SS 38	SS 39	SS 40	SS 45	SS 48	SS 50	SS 55	2.5 mm	50 mm	
Provence Lavender F (283)																							
Purple Velvet F (277)																							
Rose F (209)																							
Rose Peach F (262)																							
Ruby F (501)																							
Sapphire F (206)																							
Siam F (208)																							
Silk F (391)																							
Smoked Topaz F (220)																							
Smoky Quartz F (225)																							
Sunflower F (292)																							
Tangerine F (259)																							
Tanzanite F (539)																							
Topaz F (203)																							
Turquoise (267)																							
Vintage Rose F (319)																							
Violet F (371)																							
Opal Colors																							
Air Blue Opal F (285)																							
Caribbean Blue Opal F (394)																							
Cyclamen Opal F (398)																							
Light Grey Opal F (383)																							
Pacific Opal F (390)																							
Palace Green Opal F (393)																							
Rose Water Opal F (395)																							
Sand Opal F (287)																							
White Opal F (234)																							
Crystal Effects																							
Transparent Effects																							
Crystal AB F (001 AB)																							
Crystal Antique Pink F (001 ANTP)																							
Crystal Blue Shade F (001 BLSH)																							
Crystal Bronze Shade F (001 BRSH)																							
Crystal Golden Shadow F (001 GSHA)																							
Crystal Lilac Shadow F (001 LISH)																							
Crystal Luminous Green F (001 LUMG)																							
Crystal Moonlight F (001 MOL)																							
Crystal Silver Night F (001 SINI)																							
Crystal Silver Shade F (001 SSHA)																							

Round Stones

1088		Size	SS 18	SS 19	SS 20	SS 21	SS 22	SS 24	SS 26	SS 28	SS 29	SS 30	SS 34	SS 35	SS 38	SS 39	SS 40	SS 45	SS 48	SS 50	SS 55	25 mm	50 mm
Metallic Effects																							
	Crystal Dorado F (001 DOR)		■					■			■		■			■							
	Crystal Iridescent Green F (001 IRIG)		■					■			■		■			■					■		
	Crystal Metallic Blue F (001 METBL)		■					■			■		■			■							
	Crystal Metallic Light Gold F (001 MLGLD)		■					■			■		■			■							
	Crystal Rose Gold F (001 ROGL)		■					■			■		■			■							
Crystal Patina																							
	Crystal Black Patina F (001 BLAPA)							■			■					■							
	Crystal Gold Patina F (001 GOLPA)							■			■					■							
	Crystal Rose Patina F (001 ROSPA)							■			■					■							
	Crystal Silver Patina F (001 SILPA)							■			■					■							
	Crystal White Patina F (001 WHIPA)							■			■					■							
Color Effects																							
Metallic Effects																							
	Jet Hematite (280 HEM)		■					■			■		■			■							

1088/B XIRIUS Chaton

1088/B XIRIUS Chaton		Size	PP 14	PP 18	PP 21	PP 24
Colors						
Ceramics						
	Marbled Black (653)		■	■	■	■
	Marbled Blue (654)		■	■	■	■
	Marbled Light Grey (657)		■	■	■	■
	Marbled Terracotta (655)		■	■	■	■
	Marbled Yellow (652)		■	■	■	■

Round Stones

1100

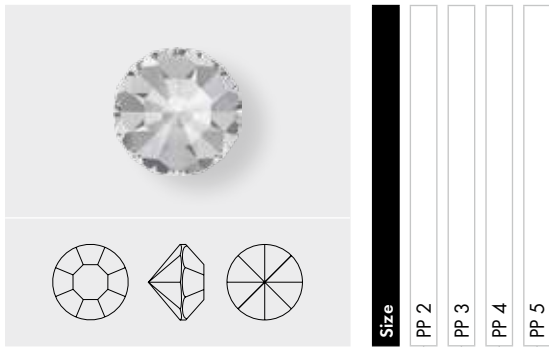

	Size	PP 2	PP 3	PP 4	PP 5
Crystal					
Crystal F (001)		■	■	■	■
Colors					
Plain Colors					
Amethyst F (204)		■	■	■	■
Aquamarine F (202)		■	■	■	■
Black Diamond F (215)		■	■	■	■
Chrysolite F (238)		■	■	■	■
Dark Moss Green F (260)		■	■	■	■
Emerald F (205)		■	■	■	■
Fuchsia F (502)		■	■	■	■
Indian Siam F (327)		■	■	■	■
Indicolite F (379)		■	■	■	■
Jet (280)		■	■	■	■
Jet F (280)		■	■	■	■
Jonquil F (213)		■	■	■	■
Light Amethyst F (212)		■	■	■	■
Light Colorado Topaz F (246)		■	■	■	■
Light Peach F (362)		■	■	■	■
Light Rose F (223)		■	■	■	■
Light Sapphire F (211)		■	■	■	■
Light Siam F (227)		■	■	■	■
Light Silk F (261)		■	■	■	■
Light Smoked Topaz F (221)		■	■	■	■
Montana F (207)		■	■	■	■
Peridot F (214)		■	■	■	■
Rose F (209)		■	■	■	■
Sapphire F (206)		■	■	■	■
Siam F (208)		■	■	■	■
Silk F (391)		■	■	■	■
Smoked Topaz F (220)		■	■	■	■
Tangerine F (259)		■	■	■	■
Topaz F (203)		■	■	■	■
Vintage Rose F (319)		■	■	■	■
Violet F (371)		■	■	■	■
Opal Colors					
White Opal F (234)		■	■	■	■

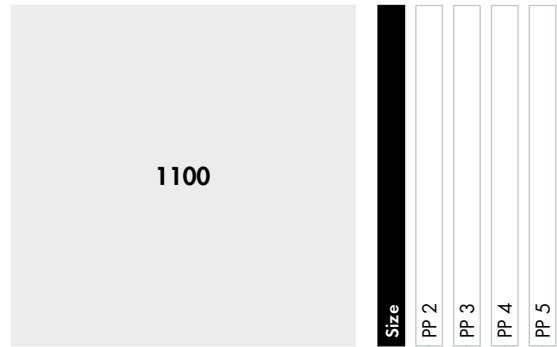

	Size	PP 2	PP 3	PP 4	PP 5
Crystal Effects					
Transparent Effects					
Crystal AB F (001 AB)			■	■	■
Crystal Golden Shadow F (001 GSHA)			■	■	■
Crystal Moonlight F (001 MOL)			■	■	■
Crystal Silver Shade F (001 SSHA)			■	■	■
Metallic Effects					
Crystal Dorado F (001 DOR)			■	■	■
Crystal Rose Gold F (001 ROGL)			■	■	■
Color Effects					
Metallic Effects					
Jet Hematite (280 HEM)			■	■	■

Round Stones

1122 Rivoli Chaton

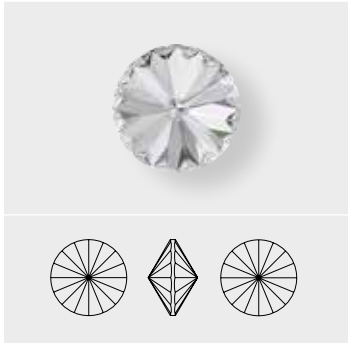

Size	SS 17	SS 24	SS 29	SS 34	SS 39	SS 47	12 mm	14 mm	16 mm	18 mm
------	-------	-------	-------	-------	-------	-------	-------	-------	-------	-------

Crystal

<input type="checkbox"/> Crystal (001)										
<input type="checkbox"/> Crystal F (001)										

Colors

Plain Colors

<input type="checkbox"/> Amethyst F (204)										
<input type="checkbox"/> Aquamarine F (202)										
<input type="checkbox"/> Black Diamond F (215)										
<input type="checkbox"/> Chrysolite F (238)										
<input type="checkbox"/> Dark Moss Green F (260)										
<input type="checkbox"/> Denim Blue F (266)										
<input type="checkbox"/> Emerald F (205)										
<input type="checkbox"/> Fuchsia F (502)										
<input type="checkbox"/> Jet (280)										
<input type="checkbox"/> Light Amethyst F (212)										
<input type="checkbox"/> Light Colorado Topaz F (246)										
<input type="checkbox"/> Light Peach F (362)										
<input type="checkbox"/> Light Rose F (223)										
<input type="checkbox"/> Light Sapphire F (211)										
<input type="checkbox"/> Light Siam F (227)										
<input type="checkbox"/> Light Silk F (261)										
<input type="checkbox"/> Light Turquoise F (263)										
<input type="checkbox"/> Montana F (207)										
<input type="checkbox"/> Olivine F (228)										
<input type="checkbox"/> Padparadscha F (542)										
<input type="checkbox"/> Peridot F (214)										
<input type="checkbox"/> Rose F (209)										
<input type="checkbox"/> Rose Peach F (262)										
<input type="checkbox"/> Sapphire F (206)										
<input type="checkbox"/> Siam F (208)										
<input type="checkbox"/> Silk F (391)										
<input type="checkbox"/> Smoked Topaz F (220)										
<input type="checkbox"/> Sunflower F (292)										
<input type="checkbox"/> Tangerine F (259)										
<input type="checkbox"/> Tanzanite F (539)										
<input type="checkbox"/> Topaz F (203)										
<input type="checkbox"/> Vintage Rose F (319)										
<input type="checkbox"/> Violet F (371)										

Round Stones

1122		Size										
		SS 17	SS 24	SS 29	SS 34	SS 39	SS 47	12 mm	14 mm	16 mm	18 mm	
Crystal Effects												
Transparent Effects												
Crystal AB F (001 AB)	■	■	■	■	■	■	■	■	■	■	■	
Crystal Antique Pink F (001 ANTP)					■	■	■	■				
Crystal Blue Shade F (001 BLSH)					■	■	■	■				
Crystal Golden Shadow F (001 GSHA)			■		■	■	■	■			■	
Crystal Lilac Shadow F (001 LISH)					■	■	■	■				
Crystal Luminous Green F (001 LUMG)					■	■	■	■				
Crystal Silver Night F (001 SINI)						■	■	■			■	
Crystal Silver Shade F (001 SSHA)			■		■	■	■	■			■	
Crystal Vitrail Light F (001 VL)			■		■	■	■	■			■	
Crystal Vitrail Medium F (001 VM)			■		■	■	■	■			■	
Metallic Effects												
Crystal Iridescent Green F (001 IRIG)					■	■	■	■			■	
Crystal Rose Gold F (001 ROGL)					■	■	■	■				
Crystal Patina												
Crystal Black Patina F (001 BLAPA)					■	■	■	■				
Crystal Gold Patina F (001 GOLPA)					■	■	■	■				
Crystal Rose Patina F (001 ROSPA)					■	■	■	■				
Crystal Silver Patina F (001 SILPA)					■	■	■	■				
Crystal White Patina F (001 WHIPA)					■	■	■	■				
Color Effects												
Metallic Effects												
Jet Hematite (280 HEM)			■		■	■	■	■			■	

Round Stones

1128

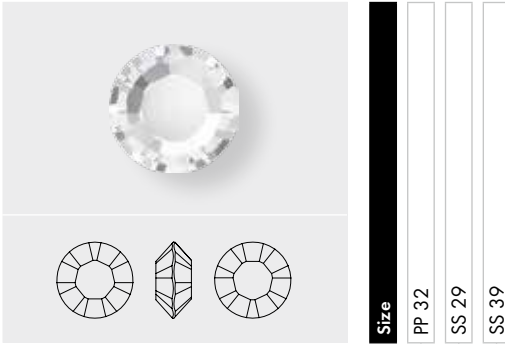

	Size	PP 32	SS 29	SS 39
Crystal				
Crystal (001)		■	■	■
Colors				
Plain Colors				
Amethyst (204)			■	
Emerald (205)			■	
Jet (280)			■	
Jonquil (213)			■	
Light Amethyst (212)			■	
Light Sapphire (211)			■	
Peridot (214)			■	
Rose (209)			■	
Sapphire (206)			■	
Siam (208)			■	
Topaz (203)			■	
Crystal Effects				
Transparent Effects				
Crystal Golden Shadow (001 GSHA)			■	

1188 XIRIUS Pointed Chaton

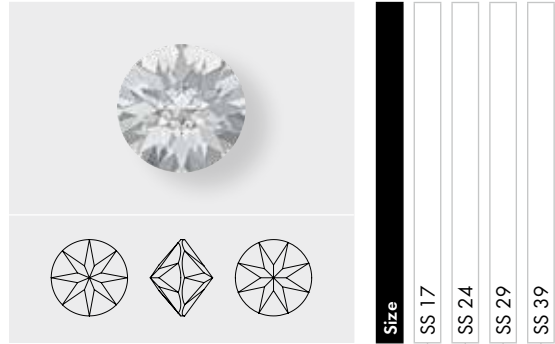

	Size	SS 17	SS 24	SS 29	SS 39
Crystal					
Crystal (001)		■	■	■	■
Crystal F (001)		■	■	■	■
Colors					
Plain Colors					
Aquamarine F (202)		■	■	■	■
Black Diamond F (215)		■	■	■	■
Dark Moss Green F (260)		■	■	■	■
Jet (280)		■	■	■	■
Light Peach F (362)		■	■	■	■
Light Rose F (223)		■	■	■	■
Light Siam F (227)		■	■	■	■
Montana F (207)		■	■	■	■
Rose F (209)		■	■	■	■
Crystal Effects					
Transparent Effects					
Crystal AB F (001 AB)		■	■	■	■
Crystal Golden Shadow F (001 GSHA)		■	■	■	■
Crystal Lilac Shadow F (001 LISH)		■	■	■	■
Crystal Luminous Green F (001 LUMG)		■	■	■	■
Crystal Silver Shade F (001 SSHA)		■	■	■	■
Metallic Effects					
Crystal Iridescent Green F (001 IRIG)		■	■	■	■
Crystal Rose Gold F (001 ROGL)		■	■	■	■
Crystal Patina					
Crystal Black Patina F (001 BLAPA)					■
Crystal Gold Patina F (001 GOLPA)					■
Crystal Rose Patina F (001 ROSPA)					■
Crystal Silver Patina F (001 SILPA)					■
Crystal White Patina F (001 WHIPA)					■

Round Stones

1201

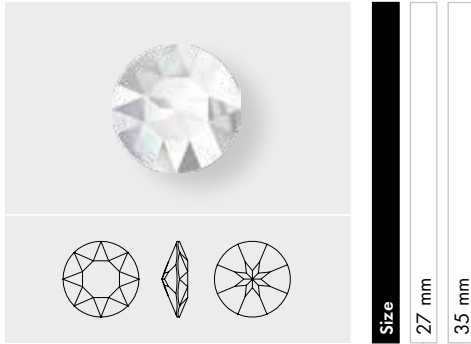

Size

27 mm

35 mm

Crystal

Crystal (001)

Crystal F (001)

Colors

Plain Colors

Aquamarine F (202)

Jet (280)

Crystal Effects

Transparent Effects

Crystal AB F (001 AB)

1318 Flower Cut

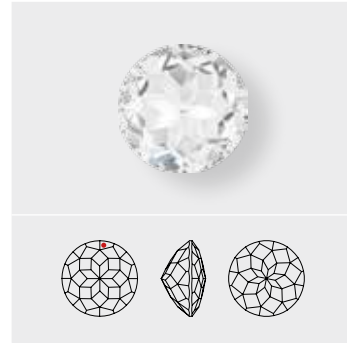

Size

30 mm

55 mm

Crystal

Crystal CAL V SI (001 CAL V SI) ¹⁾

¹⁾ These articles are delivered with a laser-engraved logo.

• The logo position is marked with a red dot.

Round Stones

1357 Brilliant Cut

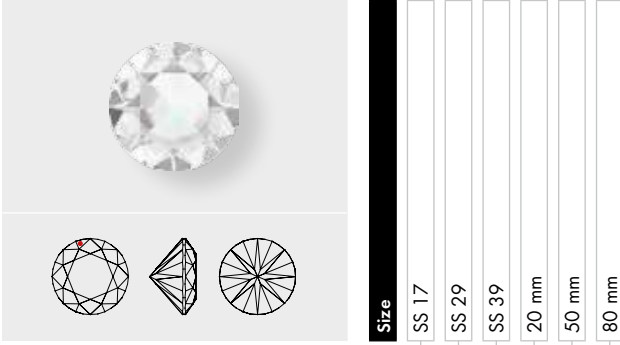

Crystal

- Crystal (001)
- Crystal F (001)
- Crystal CAL V SI (001 CAL V SI) ¹⁾

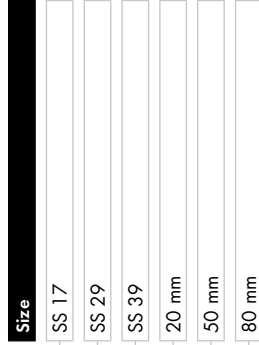

1480 Cabochon Chaton

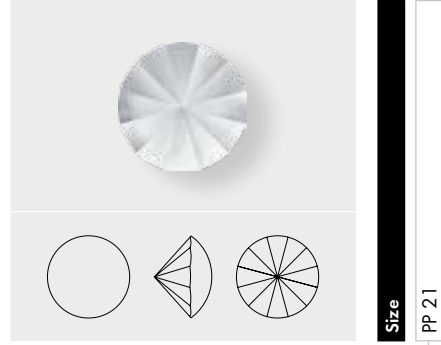

Crystal

- Crystal F (001)

Crystal Effects

Transparent Effects

- Crystal Matt Finish F (001 MATTFI)
- Crystal AB F (001 AB)
- Crystal AB Matt Finish F (001 AB MATTFI)
- Crystal Antique Pink F (001 ANTP)
- Cr. Antique Pink Matt Finish F (001 ANTP MATTFI)
- Crystal Golden Shadow F (001 GSHA)
- Cr. Golden Shadow Matt Finish F (001 GSHA MATTFI)

Metallic Effects

- Crystal Chrom V F (001 CHROM V)
- Cr. Chrom V Matt Finish F (001 CHROM V MATTFI)
- Crystal Metallic Light Gold F (001 MLGLD)
- Cr. Metallic Light Gold Matt Finish F (001 MLGLD MATTFI)

Color Effects

Metallic Effects

- Jet Hematite F (280 HEM)
- Jet Hematite Matt Finish F (280 HEM MATTFI)



¹⁾ These articles are delivered with a laser-engraved logo.
 • The logo position is marked with a red dot.

Round Stones

PRODUCT DETAILS

Article Size	Packing Unit = Minimum Order Quantity in Pieces	Average Net Weight in Gram per Packing Unit Crystal (001)	Average Gross Weight in Gram per Packing Unit Crystal (001)
1028			
PP 6	1,440	2.1	12.6
PP 7	1,440	2.3	12.5
PP 8	1,440	2.7	13.9
PP 9	1,440	3.3	13.8
PP 10	1,440	3.9	15.1
PP 11	1,440	4.7	14.9
PP 12	1,440	5.6	16.2
PP 13	1,440	6.6	17.4
1088			
PP 14	1,440	6.048	15.179
PP 15	1,440	7.258	16.389
PP 16	1,440	8.467	17.598
PP 17	1,440	9.677	18.808
PP 18	1,440	10.886	20.018
PP 19	1,440	12.096	21.227
PP 20	1,440	14.515	23.646
PP 21	1,440	15.725	24.856
PP 22	1,440	16.934	26.066
PP 23	1,440	19.354	28.485
PP 24	1,440	21.773	30.904
PP 25	1,440	25.402	34.533
PP 26	1,440	27.821	36.952
PP 27	1,440	30.240	39.371
PP 28	1,440	33.869	43.000
PP 29	1,440	36.288	45.419
PP 30	1,440	39.917	49.048
PP 31	1,440	44.755	53.886
PP 32	1,440	49.594	58.725
SS 18	1,440	59.270	68.402
SS 19	1,440	67.738	76.869
SS 20	720	38.707	47.838
SS 21	720	42.941	52.071
SS 22	720	46.570	55.700
SS 24	720	57.456	66.587
SS 26	360	40.522	49.652
SS 28	360	48.082	57.212
SS 29	288	52.920	62.051
SS 30	288	58.061	67.191
SS 34	144	31.933	41.064
SS 35	144	35.199	44.330
SS 38	144	45.723	54.854
SS 39	144	49.956	59.087
SS 40	144	54.311	63.442
SS 45	144	86.607	108.985
SS 47	144	106.082	129.427
SS 48	144	118.662	142.007
SS 50	144	143.096	167.409
SS 55	72	96.647	135.666
25 mm	8	76.8	105.37
50 mm	2	151.6	181.46

Round Stones

Article Size	Packing Unit = Minimum Order Quantity in Pieces	Average Net Weight in Gram per Packing Unit Crystal (001)	Average Gross Weight in Gram per Packing Unit Crystal (001)
1100			
PP 2	1,440	0.8	11.4
PP 3	1,440	1.0	11.3
PP 4	1,440	1.3	12.7
PP 5	1,440	1.8	12.6
1122			
SS 17	1,440	48.1	58.3
SS 24	720	46.9	57.8
SS 29	720	77.4	88.6
SS 34	360	58.4	69.3
SS 39	144	37.1	47.9
SS 47	288	158.3	184.9
12 mm	144	99.3	122.9
14 mm	144	167.1	193.4
16 mm	144	242.3	270.1
18 mm	72	181.4	208.7
1128			
PP 32	1,440	57.7	68.0
SS 29	360	53.4	64.1
SS 39	144	49.4	60.2
1188			
SS 17	1,440	53.22	62.29
SS 24	720	73.79	82.86
SS 29	288	52.25	66.36
SS 39	144	58.42	120.55
1201			
27 mm	24	174.0	212.7
35 mm	6	70.5	101.8
1318			
30 mm	24	437.5	774.5
55 mm	10	902.2	1,187.2
1357			
SS 17	720	26.8	35.9
SS 29	360	54.2	65.1
SS 39	144	52.0	62.9
20 mm	30	150.1	191.7
50 mm	12	1,017.4	1,302.4
80 mm	4	1,090.3	1,564.3
1480			
PP 21	1,440	18.3	27.5

Fancy Stones & Settings

Fancy Stones are offered in numerous shapes ranging from classical gemstone-inspired cuts to progressive trend cuts. They come in a huge assortment of different sizes and colors. Showing either a faceted or flat reverse side, Fancy Stones can be glued into pre-cast cavities or used in metal settings. Their precision-cut facets ensure the highest brilliance and endow design ideas with a unique sparkle.

Settings are unplated or plated brass components, each specifically tailored to a Fancy Stone, that secure the crystal and allow for a myriad of application possibilities, including but not limited to sewing, soldering, and gluing.

Fancy Stones & Settings

SUMMARY

1	2	3	S		1	2	3	S		1	2	3	S	
				4120 6x4, 8x6, 14x10, 18x13, 25x18 mm					4327 30x20, 40x27 mm					4524 12x6, 16x8, 23x11 mm
				4127 30x22, 39x28 mm					4328 6x3.6, 8x4.8, 10x6, 13x7.8 mm					4527 8x6, 14x10, 18x13 mm
				4128 6x4, 8x6, 10x8, 14x10 mm					4370 11x10, 15.5x14, 20x18 mm					4547 15x5, 21x7, 24x8, 30x10 mm
				4137 15x11, 22x16, 33x24 mm					4418 6, 8 mm					4565 14x10, 18x13 mm
				4139 14, 20, 30 mm					4428 1.5, 2, 3, 4, 5, 6, 8 mm					4568 8x6, 14x10, 18x13, 27x18 mm
				4161 15x5, 21x7, 27x9 mm					4439 14, 20, 30 mm					4600 6x4, 8x6, 10x8, 12x10 mm
				4196 23x20, 30x26 mm					4447 6, 8, 10, 12 mm					4610 14x10, 18x13, 20x15 mm
				4200 11x3, 15x4, 35x9.5, 48x13 mm					4461 8, 12, 16 mm					4627 27x18.5, 37x25.5 mm
				4224 10x8, 14x11, 23x18 mm					4470 10, 12, 18 mm					4675 23 mm
				4227 32x17 mm					4500 3x2, 6x2, 10x3 mm					4678 8, 14, 23 mm
				4228 4x2, 5x2.5, 6x3, 8x4, 10x5, 15x7 mm					4501 4x2, 5x2, 5x2.5, 7x3, 10x5 mm					4678/G 8, 14, 23 mm
				4230 14x9, 19x12, 23x15 mm					4502 3x1 mm					4706 7, 12, 17, 24 mm
				4320 6x4, 8x6, 10x7, 14x10, 18x13 mm					4505 8x5, 10x6, 14x8 mm					4717 15.5, 21.5 mm

1 Top view 2 Side view 3 Back view S Setting

— ... Setting available

Fancy Stones & Settings

1	2	3	S	4722 4, 6, 8, 10 mm	1	2	3	S	4795 14, 19, 28 mm
				4727 23 mm					4809 13x12, 17x15.5, 27x25 mm
				4739 14x11, 20x16 mm					4810 13x12 mm
				4744 6, 10 mm					4827 28 mm
				4745 5, 10 mm					4831 5.5x5, 8.8x8, 11x10 mm
				4747 5 mm					4835 3.5 mm
				4748 5, 10 mm					4841 4, 6, 8 mm
				4756 19x11.5, 27x16, 39x23.5 mm					4869 4, 6, 8, 10 mm
				4757 14x8.5, 19x11.5 mm					4884 5.5x5, 6.6x6, 8.8x8, 11x10, 15.4x14 mm
				4760 14x8, 18x10.5, 22x12.5 mm					
				4773 14x7.5, 18x9.5, 28x15 mm					
				4789 14, 23, 29 mm					
				4790 18x7.5, 23x10, 32x13.5 mm					

– ... Setting available

1 Top view 2 Side view 3 Back view S Setting

Fancy Stones & Settings

ARTICLE EXPLANATION & ORDERING EXAMPLE FOR SETTINGS

4120/S

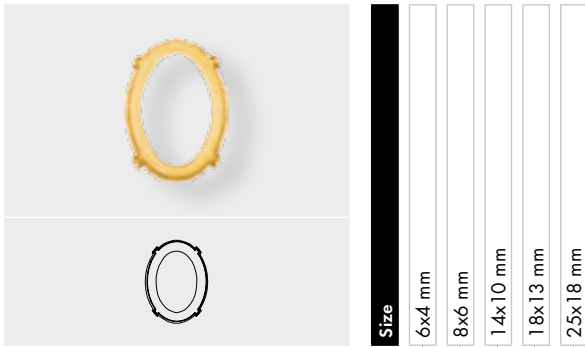

Ring/Hole, Back Configuration

- 00 C = No ring/hole, closed
- H2 O = 4 holes/2 each side, open

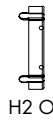
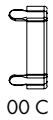

4120/S	6x4 mm	1	P	H2	O	Z
Base item number	Stone Size	Material type	type	Hole configuration	Back configuration	Plating
	Same digit code as for Fancy Stones	1 Brass	P Non-gluing element	00 No Hole H2 2 Holes	C Closed O Open	Z No Plating 3 Gold* H Rhodium*

* Anti nickel allergenic. Only available with the 2 hole (H2O) version.

Fancy Stones & Settings

4120

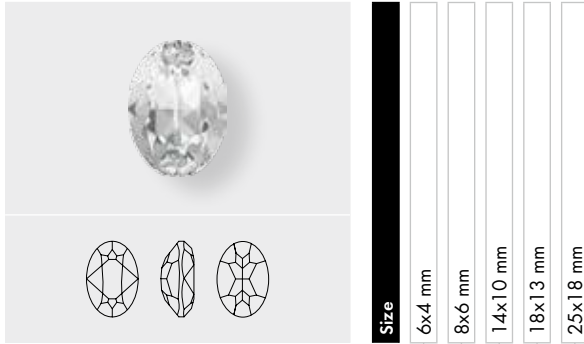

Crystal	6x4 mm	8x6 mm	14x10 mm	18x13 mm	25x18 mm
Crystal (001)	■	■	■	■	■
Crystal F (001)	■	■	■	■	■
Colors					
Plain Colors					
Amethyst F (204)	■	■	■	■	■
Aquamarine F (202)	■	■	■	■	■
Black Diamond F (215)	■	■	■	■	■
Chrysolite F (238)	■	■	■	■	■
Dark Moss Green F (260)	■	■	■	■	■
Emerald F (205)	■	■	■	■	■
Erinite F (360)	■	■	■	■	■
Fuchsia F (502)	■	■	■	■	■
Greige F (284)	■	■	■	■	■
Indian Sapphire F (217)	■	■	■	■	■
Indicolite F (379)	■	■	■	■	■
Jet (280)	■	■	■	■	■
Light Amethyst F (212)	■	■	■	■	■
Light Azure F (361)	■	■	■	■	■
Light Peach F (362)	■	■	■	■	■
Light Rose F (223)	■	■	■	■	■
Light Silk F (261)	■	■	■	■	■
Light Smoked Topaz F (221)	■	■	■	■	■
Light Turquoise F (263)	■	■	■	■	■
Montana F (207)	■	■	■	■	■
Padparadscha F (542)	■	■	■	■	■
Peridot F (214)	■	■	■	■	■
Provence Lavender F (283)	■	■	■	■	■
Rosaline F (508)	■	■	■	■	■
Rose F (209)	■	■	■	■	■
Rose Peach F (262)	■	■	■	■	■
Sapphire F (206)	■	■	■	■	■
Siam F (208)	■	■	■	■	■
Tanzanite F (539)	■	■	■	■	■
Topaz F (203)	■	■	■	■	■
Vintage Rose F (319)	■	■	■	■	■
Violet F (371)	■	■	■	■	■
Opal Colors					
Pacific Opal F (390)	■	■	■	■	■
Rose Water Opal F (395)	■	■	■	■	■
White Opal F (234)	■	■	■	■	■

4120

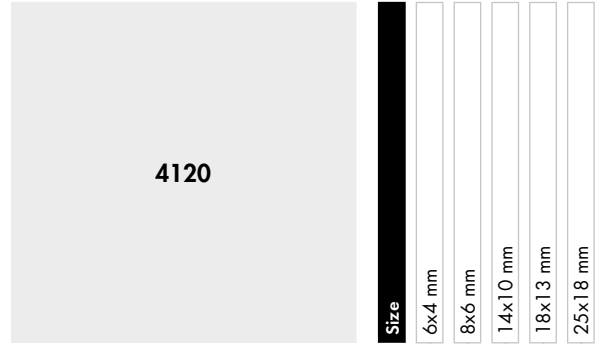

Crystal Effects	6x4 mm	8x6 mm	14x10 mm	18x13 mm	25x18 mm
Transparent Effects					
Crystal Antique Pink (001 ANTP)	■	■	■	■	■
Crystal Antique Pink F (001 ANTP)	■	■	■	■	■
Crystal Astral Pink F (001 API)	■	■	■	■	■
Crystal Blue Shade F (001 BLSH)	■	■	■	■	■
Crystal Golden Shadow (001 GSHA)	■	■	■	■	■
Crystal Golden Shadow F (001 GSHA)	■	■	■	■	■
Crystal Lilac Shadow F (001 LISH)	■	■	■	■	■
Crystal Silver Night F (001 SINI)	■	■	■	■	■
Crystal Silver Shade F (001 SSHA)	■	■	■	■	■
Metallic Effects					
Crystal Iridescent Green F (001 IRIG)	■	■	■	■	■
Crystal Rose Gold F (001 ROGL)	■	■	■	■	■
Crystal Patina					
Crystal Black Patina F (001 BLAPA)	■	■	■	■	■
Crystal Gold Patina F (001 GOLPA)	■	■	■	■	■
Crystal Rose Patina F (001 ROSPA)	■	■	■	■	■
Crystal Silver Patina F (001 SILPA)	■	■	■	■	■
Crystal White Patina F (001 WHIPA)	■	■	■	■	■

4120/S



Ring/Hole, Back Configuration	6x4 mm	8x6 mm	14x10 mm	18x13 mm	25x18 mm
00 C = No ring/hole, closed	■	■	■	■	■
H2 O = 4 holes/2 each side, open	■	■	■	■	■

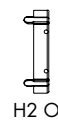

Fancy Stones & Settings

4127

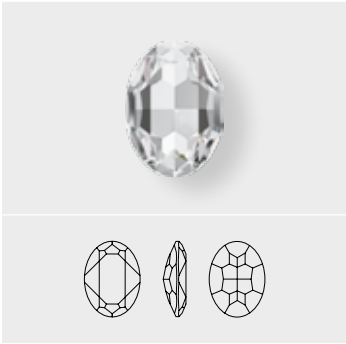

Size
30x22 mm
39x28 mm

Crystal

Crystal F (001)

Colors

Plain Colors

- Amethyst F (204)
- Aquamarine F (202)
- Black Diamond F (215)
- Burgundy F (515)
- Chrysolite F (238)
- Dark Moss Green F (260)
- Jet (280)
- Light Colorado Topaz F (246)
- Light Rose F (223)
- Light Turquoise F (263)
- Montana F (207)
- Rosaline F (508)
- Tanzanite F (539)

Opal Colors

White Opal F (234)

Crystal Effects

Transparent Effects

- Crystal AB F (001 AB)
- Crystal Antique Pink F (001 ANTP)
- Crystal Astral Pink F (001 API)
- Crystal Blue Shade F (001 BLSH)
- Crystal Golden Shadow F (001 GSHA)
- Crystal Lilac Shadow F (001 LISH)
- Crystal Luminous Green F (001 LUMG)
- Crystal Red Magma F (001 REDM)
- Crystal Silver Shade F (001 SSHA)
- Crystal Vitrail Medium (001 VM)

Metallic Effects

Crystal Iridescent Green F (001 IRIG)

Crystal Patina

- Crystal Black Patina F (001 BLAPA)
- Crystal Gold Patina F (001 GOLPA)
- Crystal Rose Patina F (001 ROSPA)
- Crystal Silver Patina F (001 SILPA)
- Crystal White Patina F (001 WHIPA)

4127/S

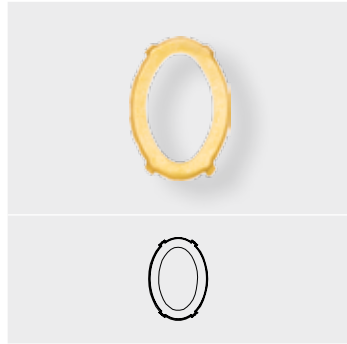

Size
30x22 mm
39x28 mm

Ring/Hole, Back Configuration

00 C = No ring/hole, closed

H2 O = 4 holes/2 each side, open



Fancy Stones & Settings

4128 XILION Oval Fancy Stone

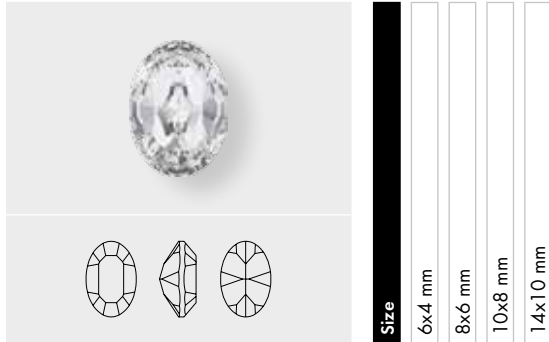

Crystal	6x4 mm	8x6 mm	10x8 mm	14x10 mm
Crystal F (001)	<input type="checkbox"/>	<input type="checkbox"/>	<input type="checkbox"/>	<input type="checkbox"/>
Colors				
Plain Colors				
Amethyst F (204)	<input type="checkbox"/>	<input type="checkbox"/>	<input type="checkbox"/>	<input type="checkbox"/>
Aquamarine F (202)	<input type="checkbox"/>	<input type="checkbox"/>	<input type="checkbox"/>	<input type="checkbox"/>
Black Diamond F (215)	<input type="checkbox"/>	<input type="checkbox"/>	<input type="checkbox"/>	<input type="checkbox"/>
Denim Blue F (266)	<input type="checkbox"/>	<input type="checkbox"/>	<input type="checkbox"/>	<input type="checkbox"/>
Emerald F (205)	<input type="checkbox"/>	<input type="checkbox"/>	<input type="checkbox"/>	<input type="checkbox"/>
Light Amethyst F (212)	<input type="checkbox"/>	<input type="checkbox"/>	<input type="checkbox"/>	<input type="checkbox"/>
Light Rose F (223)	<input type="checkbox"/>	<input type="checkbox"/>	<input type="checkbox"/>	<input type="checkbox"/>
Montana F (207)	<input type="checkbox"/>	<input type="checkbox"/>	<input type="checkbox"/>	<input type="checkbox"/>
Rose F (209)	<input type="checkbox"/>	<input type="checkbox"/>	<input type="checkbox"/>	<input type="checkbox"/>
Siam F (208)	<input type="checkbox"/>	<input type="checkbox"/>	<input type="checkbox"/>	<input type="checkbox"/>
Topaz F (203)	<input type="checkbox"/>	<input type="checkbox"/>	<input type="checkbox"/>	<input type="checkbox"/>
Crystal Effects				
Transparent Effects				
Crystal Golden Shadow F (001 GSHA)	<input type="checkbox"/>	<input type="checkbox"/>	<input type="checkbox"/>	<input type="checkbox"/>
Crystal Luminous Green F (001 LUMG)	<input type="checkbox"/>	<input type="checkbox"/>	<input type="checkbox"/>	<input type="checkbox"/>
Crystal Red Magma F (001 REDM)	<input type="checkbox"/>	<input type="checkbox"/>	<input type="checkbox"/>	<input type="checkbox"/>

4128/S



Ring/Hole, Back Configuration	6x4 mm	8x6 mm	10x8 mm	14x10 mm
00 C = No ring/hole, closed	<input type="checkbox"/>	<input type="checkbox"/>	<input type="checkbox"/>	<input type="checkbox"/>
H2 O = 4 holes/2 each side, open	<input type="checkbox"/>	<input type="checkbox"/>	<input type="checkbox"/>	<input type="checkbox"/>

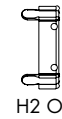
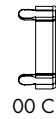

Fancy Stones & Settings

4137 Cosmic Oval Fancy Stone



Size	15x11 mm	22x16 mm	33x24 mm
------	----------	----------	----------

- Crystal**
- Crystal (001)
- Crystal CAL V SI (001 CAL V SI)
- Colors**
- Plain Colors**
- Jet (280)
- Crystal Effects**
- Transparent Effects**
- Crystal Golden Shadow (001 GSHA)

4139 Cosmic Ring Fancy Stone

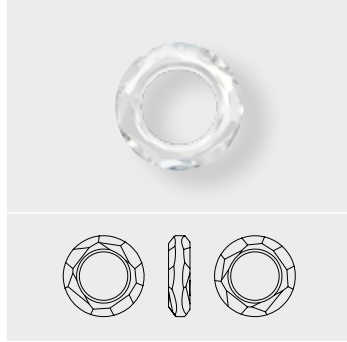

Size	14 mm	20 mm	30 mm
------	-------	-------	-------

- Crystal**
- Crystal (001)
- Crystal CAL V SI (001 CAL V SI)
- Colors**
- Plain Colors**
- Jet (280)
- Crystal Effects**
- Transparent Effects**
- Crystal AB (001 AB)
- Crystal Antique Pink (001 ANTP)
- Crystal Astral Pink (001 API)
- Crystal Bermuda Blue (001 BBL)
- Crystal Blue Shade (001 BLSH)
- Crystal Golden Shadow (001 GSHA)
- Crystal Lilac Shadow (001 LISH)
- Crystal Luminous Green (001 LUMG)
- Crystal Silver Night (001 SINI)
- Crystal Silver Shade (001 SSHA)
- Crystal Silver Shade CAL V SI (001 SSHA CAL V SI)
- Crystal Vitrail Light (001 VL)
- Crystal Volcano (001 VOL)

Fancy Stones & Settings

4161 Long Classical Oval Fancy Stone

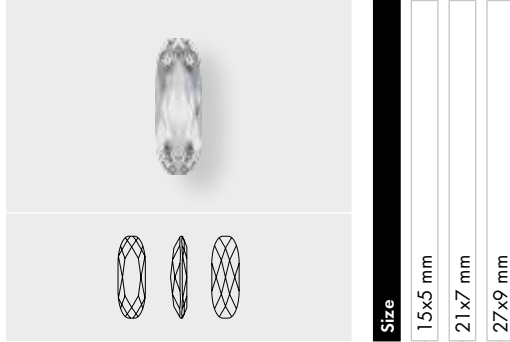

Crystal

Crystal F (001)

Colors

Plain Colors

Amethyst F (204)

Aquamarine F (202)

Indicolite F (379)

Light Colorado Topaz F (246)

Light Rose F (223)

Light Turquoise F (263)

Olivine F (228)

Padparadscha F (542)

Crystal Effects

Transparent Effects

Crystal Astral Pink F (001 API)

4161/S

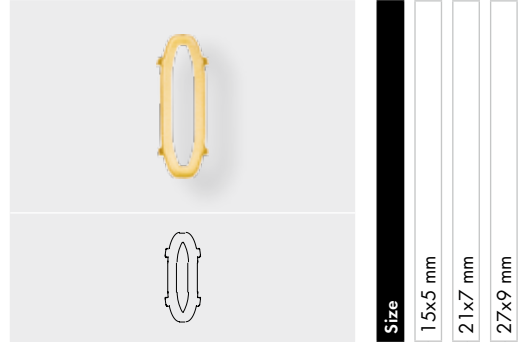

Ring/Hole, Back Configuration

00 C = No ring/hole, closed

H2 O = 4 holes/2 each side, open

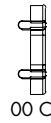

00 C

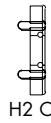

H2 O

4196 Nautilus Fancy Stone

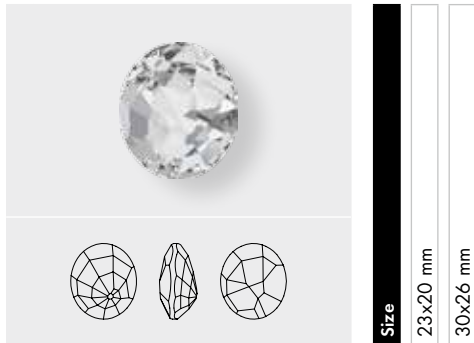

Crystal

Crystal F (001)

Colors

Plain Colors

Black Diamond F (215)

Light Amethyst F (212)

Light Azure F (361)

Light Colorado Topaz F (246)

Montana F (207)

Silk F (391)

4196/S



Ring/Hole, Back Configuration

00 C = No ring/hole, closed

H2 O = 4 holes/2 each side, open



00 C

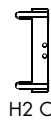

H2 O

Fancy Stones & Settings

4200 Sphinx Eye Fancy Stone

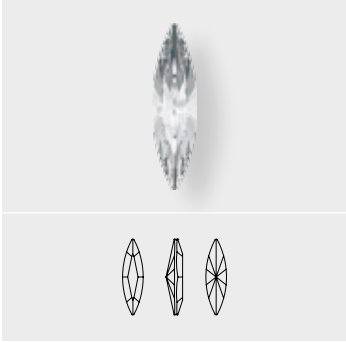

Size	11x3 mm	15x4 mm	35x9.5 mm	48x13 mm
------	---------	---------	-----------	----------

Crystal	11x3 mm	15x4 mm	35x9.5 mm	48x13 mm
Crystal F (001)	■	■	■	■
Colors				
Plain Colors				
Denim Blue F (266)			■	■
Jet (280)	■	■	■	■
Crystal Effects				
Transparent Effects				
Crystal Golden Shadow F (001_GSHA)	■	■	■	■
Crystal Silver Shade F (001_SSHA)			■	■
Color Effect				
Metallic Effects				
Jet Hematite (280_HEM)			■	■

4200/S

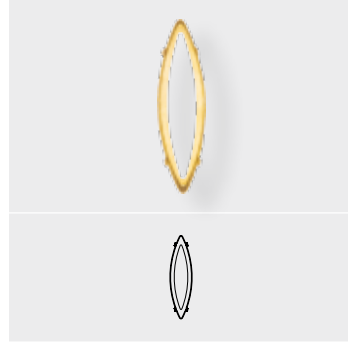

Size	11x3 mm	15x4 mm	35x9.5 mm	48x13 mm
------	---------	---------	-----------	----------

Ring/Hole, Back Configuration	11x3 mm	15x4 mm	35x9.5 mm	48x13 mm
00 C = No ring/hole, closed	■	■	■	■
H2 O = 4 holes/2 each side, open	■	■	■	■

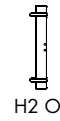
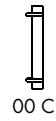

Fancy Stones & Settings

4224 Pure Leaf Fancy Stone

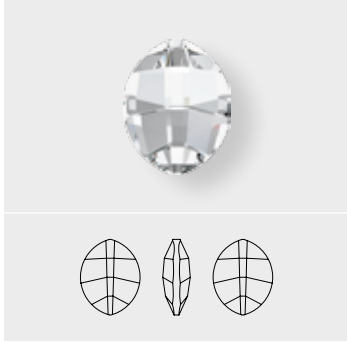

Size 10x8, 14x11 mm

4224 Pure Leaf Fancy Stone

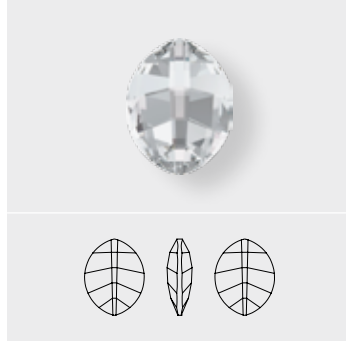

Size 23x18 mm

4224

	Size 10x8 mm	Size 14x11 mm	Size 23x18 mm
Crystal			
Crystal F (001)	■	■	■
Colors			
Plain Colors			
Amethyst F (204)	■	■	■
Dark Moss Green F (260)	■	■	■
Emerald F (205)	■	■	■
Peridot F (214)	■	■	■
Jet (280)	■	■	■
Opal Colors			
White Opal F (234)	■	■	■
Crystal Effects			
Transparent Effects			
Crystal AB F (001 AB)	■	■	■
Crystal Blue Shade F (001 BLSH)	■	■	■
Crystal Golden Shadow F (001 GSHA)	■	■	■
Crystal Luminous Green F (001 LUMG)	■	■	■
Crystal Red Magma F (001 REDM)	■	■	■
Crystal Silver Night (001 SINI)	■	■	■
Crystal Patina			
Crystal Black Patina F (001 BLAPA)	■	■	■
Crystal Gold Patina F (001 GOLPA)	■	■	■
Crystal Rose Patina F (001 ROSPA)	■	■	■
Crystal Silver Patina F (001 SILPA)	■	■	■
Crystal White Patina F (001 WHIPA)	■	■	■

4224/S

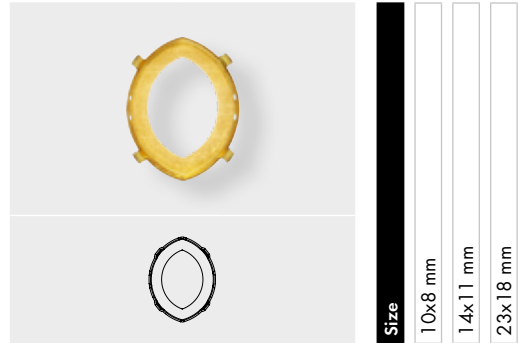

Ring/Hole, Back Configuration

00 C = No ring/hole, closed

H2 O = 4 holes/2 each side, open

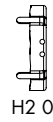
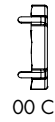

	Size 10x8 mm	Size 14x11 mm	Size 23x18 mm
00 C	■	■	■
H2 O	■	■	■

Fancy Stones & Settings

4227

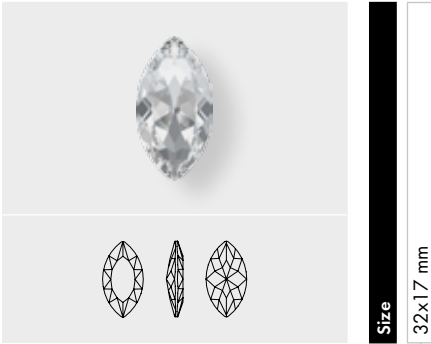

Size

32x17 mm

Crystal

Crystal F (001)

Colors

Plain Colors

Jet (280)

Crystal Effects

Transparent Effects

Crystal AB F (001 AB)

Crystal Golden Shadow F (001 GSHA)

Crystal Silver Shade F (001 SSHA)

4227/S

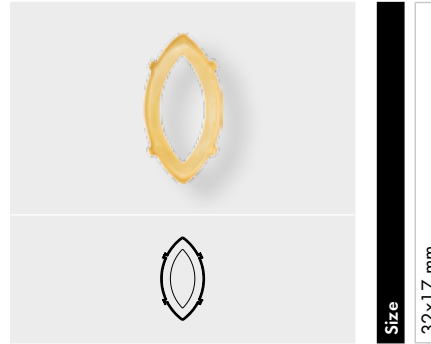

Size

32x17 mm

Ring/Hole, Back Configuration

00 C = No ring/hole, closed

H2 O = 4 holes/2 each side, open

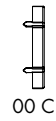

00 C

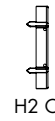

H2 O

Fancy Stones & Settings

4228



Size 4x2, 5x2.5 mm

4228 XILLION Navette Fancy Stone



Size 6x3, 8x4, 10x5, 15x7 mm



Crystal	4x2 mm	5x2.5 mm	6x3 mm	8x4 mm	10x5 mm	15x7 mm
Crystal F (001)	■	■	■	■	■	■
Colors						
Plain Colors						
Amethyst F (204)	■	■	■	■	■	■
Aquamarine F (202)	■	■	■	■	■	■
Black Diamond F (215)	■	■	■	■	■	■
Dark Moss Green F (260)	■	■	■	■	■	■
Denim Blue F (266)	■	■	■	■	■	■
Emerald F (205)	■	■	■	■	■	■
Fuchsia F (502)	■	■	■	■	■	■
Greige F (284)	■	■	■	■	■	■
Indian Siam F (327)	■	■	■	■	■	■
Indicolite F (379)	■	■	■	■	■	■
Jet (280)	■	■	■	■	■	■
Jonquil F (213)	■	■	■	■	■	■
Light Amethyst F (212)	■	■	■	■	■	■
Light Colorado Topaz F (246)	■	■	■	■	■	■
Light Rose F (223)	■	■	■	■	■	■
Light Sapphire F (211)	■	■	■	■	■	■
Light Siam F (227)	■	■	■	■	■	■
Light Silk F (261)	■	■	■	■	■	■
Light Turquoise F (263)	■	■	■	■	■	■
Montana F (207)	■	■	■	■	■	■
Padparadscha F (542)	■	■	■	■	■	■
Peridot F (214)	■	■	■	■	■	■
Provence Lavender F (283)	■	■	■	■	■	■
Purple Velvet F (277)	■	■	■	■	■	■
Rosaline F (508)	■	■	■	■	■	■
Rose F (209)	■	■	■	■	■	■
Rose Peach F (262)	■	■	■	■	■	■
Sapphire F (206)	■	■	■	■	■	■
Siam F (208)	■	■	■	■	■	■
Smoked Topaz F (220)	■	■	■	■	■	■
Tangerine F (259)	■	■	■	■	■	■
Tanzanite F (539)	■	■	■	■	■	■
Topaz F (203)	■	■	■	■	■	■
Opal Colors						
Chrysolite Opal F (294)	■	■	■	■	■	■
Pacific Opal F (390)	■	■	■	■	■	■
White Opal F (234)	■	■	■	■	■	■

Fancy Stones & Settings

4228		Size	4x2 mm	5x2.5 mm	6x3 mm	8x4 mm	10x5 mm	15x7 mm
Crystal Effects								
Transparent Effects								
	Crystal AB F (001 AB)		■	■	■	■	■	■
	Crystal Antique Pink F (001 ANTP)			■	■	■	■	■
	Crystal Astral Pink F (001 API)		■	■	■	■	■	■
	Crystal Blue Shade F (001 BLSH)		■	■	■	■	■	■
	Crystal Golden Shadow F (001 GSHA)		■	■	■	■	■	■
	Crystal Lilac Shadow F (001 LISH)		■	■	■	■	■	■
	Crystal Luminous Green F (001 LUMG)			■	■	■	■	■
	Crystal Red Magma F (001 REDM)		■	■	■	■	■	■
	Crystal Silver Night F (001 SINI)			■	■	■	■	■
	Crystal Silver Shade F (001 SSHA)		■	■	■	■	■	■
Metallic Effects								
	Crystal Iridescent Green F (001 IRIG)			■	■	■	■	■
	Crystal Rose Gold F (001 ROGL)			■	■	■	■	■
Color Effects								
Metallic Effects								
	Jet Hematite (280 HEM)		■	■	■	■	■	■

4228/S

4228/S		Size	5x2.5 mm	6x3 mm	8x4 mm	10x5 mm	15x7 mm
Ring/Hole, Back Configuration							
<input type="checkbox"/>	00 C = No ring/hole, closed		■	■	■	■	■
<input type="checkbox"/>	H2 O = 4 holes/2 each side, open		■	■	■	■	■
	00 C						
	H2 O						

Fancy Stones & Settings

4230 Lemon Fancy Stone

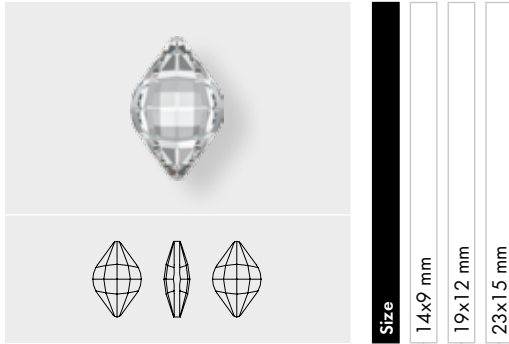

Crystal	14x9 mm	19x12 mm	23x15 mm
Crystal F (001)	<input type="checkbox"/>	<input type="checkbox"/>	<input type="checkbox"/>
Colors			
Plain Colors			
Amethyst F (204)	<input type="checkbox"/>	<input type="checkbox"/>	<input type="checkbox"/>
Aquamarine F (202)	<input type="checkbox"/>	<input type="checkbox"/>	<input type="checkbox"/>
Dark Moss Green F (260)	<input type="checkbox"/>	<input type="checkbox"/>	<input type="checkbox"/>
Erinite F (360)	<input type="checkbox"/>	<input type="checkbox"/>	<input type="checkbox"/>
Light Siam F (227)	<input type="checkbox"/>	<input type="checkbox"/>	<input type="checkbox"/>
Light Silk F (261)	<input type="checkbox"/>	<input type="checkbox"/>	<input type="checkbox"/>
Light Smoked Topaz F (221)	<input type="checkbox"/>	<input type="checkbox"/>	<input type="checkbox"/>
Light Topaz F (226)	<input type="checkbox"/>	<input type="checkbox"/>	<input type="checkbox"/>
Rosaline F (508)	<input type="checkbox"/>	<input type="checkbox"/>	<input type="checkbox"/>
Opal Colors			
White Opal F (234)	<input type="checkbox"/>	<input type="checkbox"/>	<input type="checkbox"/>
Crystal Effects			
Transparent Effects			
Crystal Antique Pink F (001 ANTP)	<input type="checkbox"/>	<input type="checkbox"/>	<input type="checkbox"/>
Crystal Blue Shade F (001 BLSH)	<input type="checkbox"/>	<input type="checkbox"/>	<input type="checkbox"/>
Crystal Golden Shadow F (001 GSHA)	<input type="checkbox"/>	<input type="checkbox"/>	<input type="checkbox"/>
Crystal Silver Night F (001 SINI)	<input type="checkbox"/>	<input type="checkbox"/>	<input type="checkbox"/>

4230/S

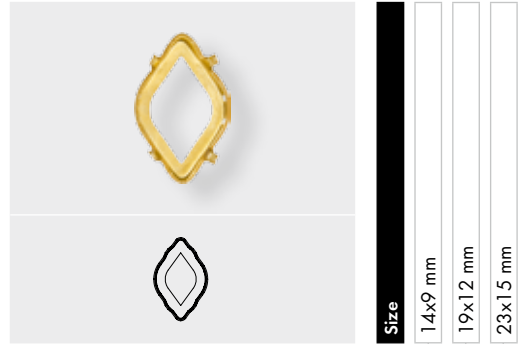

Ring/Hole, Back Configuration	14x9 mm	19x12 mm	23x15 mm
00 C = No ring/hole, closed	<input type="checkbox"/>	<input type="checkbox"/>	<input type="checkbox"/>
H2 O = 4 holes/2 each side, open	<input type="checkbox"/>	<input type="checkbox"/>	<input type="checkbox"/>



00 C



H2 O

Fancy Stones & Settings

4320

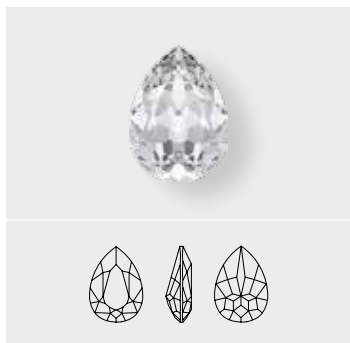

Size	6x4 mm	8x6 mm	10x7 mm	14x10 mm	18x13 mm
------	--------	--------	---------	----------	----------

Crystal

- Crystal (001)
- Crystal F (001)

Colors

Plain Colors

- Amethyst F (204)
- Aquamarine F (202)
- Black Diamond F (215)
- Dark Moss Green F (260)
- Denim Blue F (266)
- Emerald F (205)
- Fern Green F (291)
- Greige F (284)
- Jet (280)
- Light Colorado Topaz F (246)
- Light Silk F (261)
- Light Turquoise F (263)
- Montana F (207)
- Olivine F (228)
- Padparadscha F (542)
- Provence Lavender F (283)
- Rosaline F (508)
- Rose F (209)
- Rose Peach F (262)
- Siam F (208)
- Tangerine F (259)
- Tanzanite F (539)
- Vintage Rose F (319)

Opal Colors

- Caribbean Blue Opal F (394)
- Chrysolite Opal F (294)
- Pacific Opal F (390)
- Rose Water Opal F (395)
- White Opal F (234)

Crystal Effects

Transparent Effects

- Crystal AB F (001 AB)
- Crystal Antique Pink F (001 ANTP)
- Crystal Astral Pink F (001 API)
- Crystal Blue Shade F (001 BLSH)
- Crystal Golden Shadow F (001 GSHA)

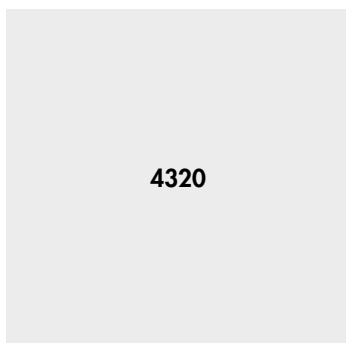

4320

Size	6x4 mm	8x6 mm	10x7 mm	14x10 mm	18x13 mm
------	--------	--------	---------	----------	----------

- Crystal Lilac Shadow F (001 LISH)
- Crystal Luminous Green F (001 LUMG)
- Crystal Moonlight F (001 MOL)
- Crystal Red Magma F (001 REDM)
- Crystal Silver Night F (001 SINI)
- Crystal Silver Shade F (001 SSHA)
- Metallic Effects**
- Crystal Iridescent Green F (001 IRIG)
- Crystal Metallic Light Gold F (001 MLGLD)
- Crystal Rose Gold F (001 ROGL)
- Crystal Patina**
- Crystal Black Patina F (001 BLAPA)
- Crystal Gold Patina F (001 GOLPA)
- Crystal Rose Patina F (001 ROSPA)
- Crystal Silver Patina F (001 SILPA)
- Crystal White Patina F (001 WHIPA)

4320/S



Size	6x4 mm	8x6 mm	10x7 mm	14x10 mm	18x13 mm
------	--------	--------	---------	----------	----------

Ring/Hole, Back Configuration

- 00 C = No ring/hole, closed
- H2 O = 4 holes/2 each side, open

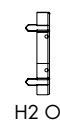
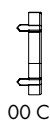

Fancy Stones & Settings

4327

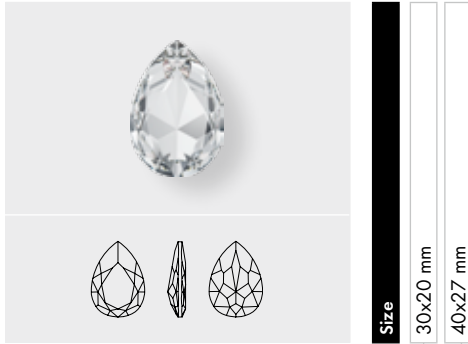

Size
30x20 mm
40x27 mm

Crystal

Crystal F (001)

Colors

Plain Colors

- Amethyst F (204)
- Aquamarine F (202)
- Black Diamond F (215)
- Chrysolite F (238)
- Dark Moss Green F (260)
- Fuchsia F (502)
- Jet (280)
- Light Colorado Topaz F (246)
- Light Rose F (223)
- Montana F (207)
- Rosaline F (508)
- Tanzanite F (539)

Opal Colors

White Opal F (234)

Crystal Effects

Transparent Effects

- Crystal AB F (001 AB)
- Crystal Antique Pink F (001 ANTP)
- Crystal Astral Pink F (001 API)
- Crystal Golden Shadow F (001 GSHA)
- Crystal Lilac Shadow F (001 LISH)
- Crystal Luminous Green F (001 LUMG)
- Crystal Red Magma F (001 REDM)
- Crystal Silver Shade F (001 SSHA)
- Crystal Vitrail Medium (001 VM)

Metallic Effects

Crystal Iridescent Green F (001 IRIG)

Crystal Patina

- Crystal Black Patina F (001 BLAPA)
- Crystal Gold Patina F (001 GOLPA)
- Crystal Rose Patina F (001 ROSPA)
- Crystal Silver Patina F (001 SILPA)
- Crystal White Patina F (001 WHIPA)

4327/S

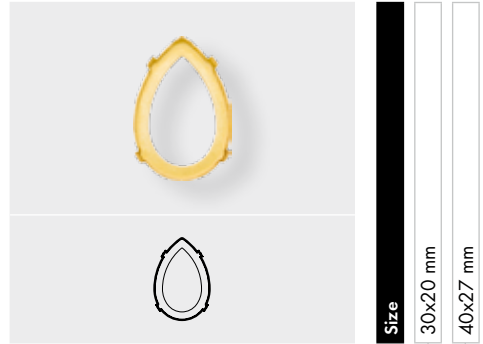

Size
30x20 mm
40x27 mm

Ring/Hole, Back Configuration

00 C = No ring/hole, closed

H2 O = 4 holes/2 each side, open

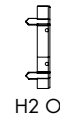
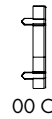

Fancy Stones & Settings

4328 XILION Pear Fancy Stone



Size	6x3.6 mm	8x4.8 mm	10x6 mm	13x7.8 mm
------	----------	----------	---------	-----------

- Crystal**
 - Crystal F (001)
- Colors**
- Plain Colors**
 - Amethyst F (204)
 - Aquamarine F (202)
 - Black Diamond F (215)
 - Emerald F (205)
 - Jet (280)
 - Light Amethyst F (212)
 - Light Colorado Topaz F (246)
 - Light Rose F (223)
 - Montana F (207)
 - Rose F (209)
 - Siam F (208)
 - Tanzanite F (539)
- Crystal Effects**
- Transparent Effects**
 - Crystal Golden Shadow F (001 GSHA)
 - Crystal Luminous Green F (001 LUMG)

4328/S



Size	6x3.6 mm	8x4.8 mm	10x6 mm	13x7.8 mm
------	----------	----------	---------	-----------

- Ring/Hole, Back Configuration**
 - 00 C = No ring/hole, closed
 - H2 O = 4 holes/2 each side, open



4370

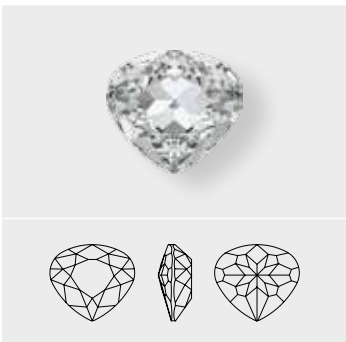

Size	11x10 mm	15.5x14 mm	20x18 mm
------	----------	------------	----------

- Crystal**
 - Crystal F (001)
- Colors**
- Plain Colors**
 - Tanzanite (539)
- Crystal Effects**
- Transparent Effects**
 - Crystal Golden Shadow (001 GSHA)

4370/S



Size	11x10 mm	15.5x14 mm	20x18 mm
------	----------	------------	----------

- Ring/Hole, Back Configuration**
 - 00 C = No ring/hole, closed
 - H2 O = 4 holes/2 each side, open



Fancy Stones & Settings

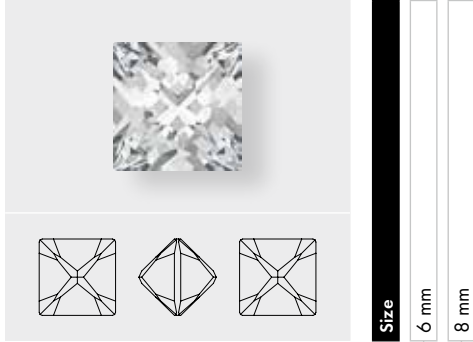

4418 XILION Pointed Square Fancy Stone

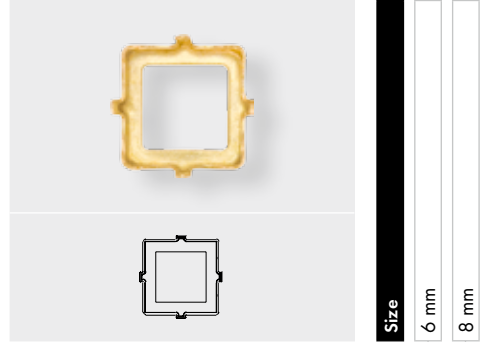

	6 mm	8 mm
Crystal		
Crystal (001)	<input type="checkbox"/>	<input type="checkbox"/>
Crystal F (001)	<input type="checkbox"/>	<input type="checkbox"/>
Colors		
Plain Colors		
Aquamarine F (202)	<input type="checkbox"/>	<input type="checkbox"/>
Black Diamond F (215)	<input type="checkbox"/>	<input type="checkbox"/>
Dark Moss Green F (260)	<input type="checkbox"/>	<input type="checkbox"/>
Jet (280)	<input type="checkbox"/>	<input type="checkbox"/>
Light Rose F (223)	<input type="checkbox"/>	<input type="checkbox"/>
Montana F (207)	<input type="checkbox"/>	<input type="checkbox"/>
Tanzanite F (539)	<input type="checkbox"/>	<input type="checkbox"/>
Crystal Effects		
Transparent Effects		
Crystal AB F (001 AB)	<input type="checkbox"/>	<input type="checkbox"/>
Crystal Golden Shadow F (001 GSHA)	<input type="checkbox"/>	<input type="checkbox"/>
Crystal Lilac Shadow F (001 LISH)	<input type="checkbox"/>	<input type="checkbox"/>
Crystal Luminous Green F (001 LUMG)	<input type="checkbox"/>	<input type="checkbox"/>
Crystal Silver Shade F (001 SSHA)	<input type="checkbox"/>	<input type="checkbox"/>
Metallic Effects		
Crystal Rose Gold F (001 ROGL)	<input type="checkbox"/>	<input type="checkbox"/>
Crystal Patina		
Crystal Black Patina F (001 BLAPA)	<input type="checkbox"/>	<input type="checkbox"/>
Crystal Gold Patina F (001 GOLPA)	<input type="checkbox"/>	<input type="checkbox"/>
Crystal Rose Patina F (001 ROSPA)	<input type="checkbox"/>	<input type="checkbox"/>
Crystal Silver Patina F (001 SILPA)	<input type="checkbox"/>	<input type="checkbox"/>
Crystal White Patina F (001 WHIPA)	<input type="checkbox"/>	<input type="checkbox"/>

4418/S



	6 mm	8 mm
Ring/Hole, Back Configuration		
00 C = No ring/hole, closed	<input type="checkbox"/>	<input type="checkbox"/>
H2 O = 4 holes/2 each side, open	<input type="checkbox"/>	<input type="checkbox"/>
<div style="display: flex; justify-content: space-around; align-items: center;"> <div style="text-align: center;">  <p>00 C</p> </div> <div style="text-align: center;">  <p>H2 O</p> </div> </div>		

Fancy Stones & Settings

4428

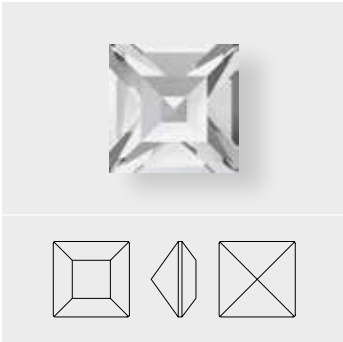

Size 1.5, 2 mm

4428 XILION Square Fancy Stone

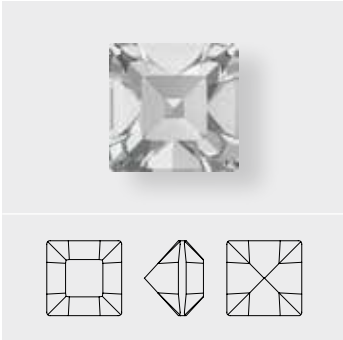

Size 3, 4 mm

4428 XILION Square Fancy Stone

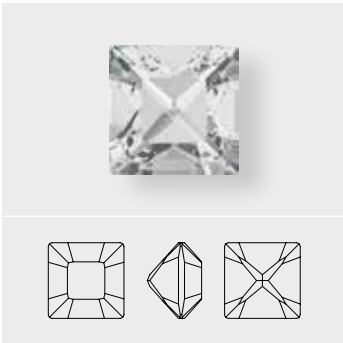

Size 5, 6, 8 mm

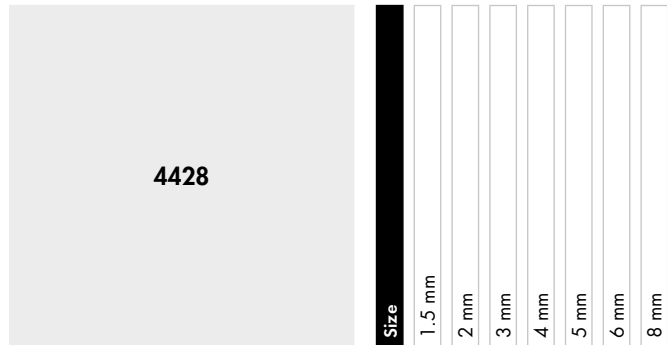

Crystal

Crystal F (001)

Colors

Plain Colors

Amethyst F (204)

Aquamarine F (202)

Black Diamond F (215)

Burgundy F (515)

Dark Moss Green F (260)

Denim Blue F (266)

Emerald F (205)

Fuchsia F (502)

Greige F (284)

Indicolite F (379)

Jet (280)

Light Amethyst F (212)

Light Colorado Topaz F (246)

Light Peach F (362)

Light Rose F (223)

Light Sapphire F (211)

Light Siam F (227)

Light Silk F (261)

Light Smoked Topaz F (221)

Light Turquoise F (263)

Montana F (207)

Peridot F (214)

Rose F (209)

Rose Peach F (262)

Sapphire F (206)

Siam F (208)

Smoked Topaz F (220)

Smoky Quartz F (225)

Tangerine F (259)

Tanzanite F (539)

Violet F (371)

Opal Colors

White Opal F (234)

Crystal Effects

Transparent Effects

Crystal AB F (001 AB)

Crystal Antique Pink F (001 ANTP)

Size
1.5 mm
2 mm
3 mm
4 mm
5 mm
6 mm
8 mm

Crystal F (001)	■	■	■	■	■	■	■
Amethyst F (204)	■	■	■	■	■	■	■
Aquamarine F (202)	■	■	■	■	■	■	■
Black Diamond F (215)	■	■	■	■	■	■	■
Burgundy F (515)	■	■	■	■	■	■	■
Dark Moss Green F (260)	■	■	■	■	■	■	■
Denim Blue F (266)	■	■	■	■	■	■	■
Emerald F (205)	■	■	■	■	■	■	■
Fuchsia F (502)	■	■	■	■	■	■	■
Greige F (284)	■	■	■	■	■	■	■
Indicolite F (379)	■	■	■	■	■	■	■
Jet (280)	■	■	■	■	■	■	■
Light Amethyst F (212)	■	■	■	■	■	■	■
Light Colorado Topaz F (246)	■	■	■	■	■	■	■
Light Peach F (362)	■	■	■	■	■	■	■
Light Rose F (223)	■	■	■	■	■	■	■
Light Sapphire F (211)	■	■	■	■	■	■	■
Light Siam F (227)	■	■	■	■	■	■	■
Light Silk F (261)	■	■	■	■	■	■	■
Light Smoked Topaz F (221)	■	■	■	■	■	■	■
Light Turquoise F (263)	■	■	■	■	■	■	■
Montana F (207)	■	■	■	■	■	■	■
Peridot F (214)	■	■	■	■	■	■	■
Rose F (209)	■	■	■	■	■	■	■
Rose Peach F (262)	■	■	■	■	■	■	■
Sapphire F (206)	■	■	■	■	■	■	■
Siam F (208)	■	■	■	■	■	■	■
Smoked Topaz F (220)	■	■	■	■	■	■	■
Smoky Quartz F (225)	■	■	■	■	■	■	■
Tangerine F (259)	■	■	■	■	■	■	■
Tanzanite F (539)	■	■	■	■	■	■	■
Violet F (371)	■	■	■	■	■	■	■
White Opal F (234)	■	■	■	■	■	■	■
Crystal AB F (001 AB)	■	■	■	■	■	■	■
Crystal Antique Pink F (001 ANTP)	■	■	■	■	■	■	■

Fancy Stones & Settings

4428		Size	1.5 mm	2 mm	3 mm	4 mm	5 mm	6 mm	8 mm
	Crystal Blue Shade F (001 BLSH)		■	■	■	■		■	■
	Crystal Golden Shadow F (001 GSHA)		■	■	■	■		■	■
	Crystal Lilac Shadow F (001 LISH)		■	■	■	■		■	■
	Crystal Luminous Green F (001 LUMG)		■	■	■	■		■	■
	Crystal Silver Night F (001 SINI)		■	■	■	■		■	■
	Crystal Silver Shade F (001 SSHA)		■	■	■	■		■	■
Metallic Effects									
	Crystal Iridescent Green F (001 IRIG)			■	■	■		■	■
	Crystal Metallic Light Gold F (001 MLGD)		■	■	■	■		■	■
	Crystal Rose Gold F (001 ROGL)		■	■	■	■		■	■
Color Effects									
Metallic Effects									
	Jet Hematite (280 HEM)		■	■	■	■			

4428/S

4428/S		Size	4 mm	5 mm	6 mm	8 mm

Ring/Hole, Back Configuration		4 mm	5 mm	6 mm	8 mm
<input type="checkbox"/>	00 C = No ring/hole, closed	■	■	■	■
<input type="checkbox"/>	H2 O = 4 holes/2 each side, open	■	■	■	■

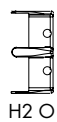
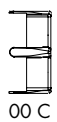

Fancy Stones & Settings

4439 Square Ring Fancy Stone

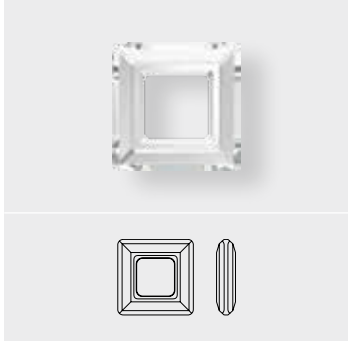

Size	14 mm	20 mm	30 mm
------	-------	-------	-------

Crystal

<input type="checkbox"/> Crystal (001)	<input type="checkbox"/>	<input type="checkbox"/>	<input type="checkbox"/>
<input type="checkbox"/> Crystal CAL V SI (001 CAL V SI)	<input type="checkbox"/>	<input type="checkbox"/>	<input type="checkbox"/>

Colors

Plain Colors

<input type="checkbox"/> Jet (280)	<input type="checkbox"/>	<input type="checkbox"/>	
------------------------------------	--------------------------	--------------------------	--

Crystal Effects

Transparent Effects

<input type="checkbox"/> Crystal AB (001 AB)	<input type="checkbox"/>	<input type="checkbox"/>	
<input type="checkbox"/> Crystal Bermuda Blue (001 BBL)	<input type="checkbox"/>	<input type="checkbox"/>	
<input type="checkbox"/> Crystal Golden Shadow (001 GSHA)	<input type="checkbox"/>	<input type="checkbox"/>	
<input type="checkbox"/> Crystal Lilac Shadow (001 LISH)	<input type="checkbox"/>	<input type="checkbox"/>	
<input type="checkbox"/> Crystal Luminous Green (001 LUMG)	<input type="checkbox"/>	<input type="checkbox"/>	
<input type="checkbox"/> Crystal Silver Night (001 SINI)	<input type="checkbox"/>	<input type="checkbox"/>	
<input type="checkbox"/> Crystal Vitrail Light (001 VL)	<input type="checkbox"/>	<input type="checkbox"/>	
<input type="checkbox"/> Crystal Volcano (001 VOL)	<input type="checkbox"/>	<input type="checkbox"/>	

Fancy Stones & Settings

4447 Princess Square Fancy Stone



Crystal	6 mm	8 mm	10 mm	12 mm
Crystal F (001)	■	■	■	■
Colors				
Plain Colors				
Aquamarine F (202)				■
Tanzanite F (539)				■
Crystal Effects				
Transparent Effects				
Crystal Golden Shadow F (001 GSHA)	■	■	■	■
Crystal Silver Shade F (001 SSHA)	■	■	■	■

4447/S

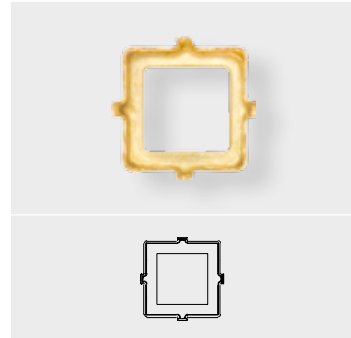

Ring/Hole, Back Configuration	6 mm	8 mm	10 mm	12 mm
00 C = No ring/hole, closed	■	■	■	■
H2 O = 4 holes/2 each side, open	■	■	■	■

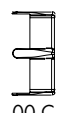

00 C

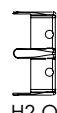

H2 O

4461 Classical Square Fancy Stone

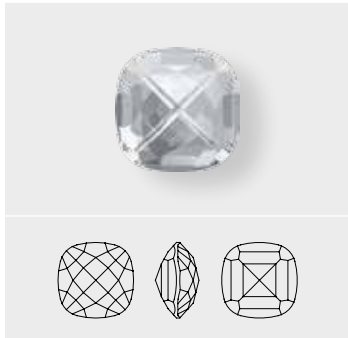

Crystal	8 mm	12 mm	16 mm
Crystal F (001)	■	■	■
Crystal Effects			
Transparent Effects			
Crystal Golden Shadow F (001 GSHA)	■	■	■
Crystal Satin F (001 SAT)	■	■	■
Crystal Silver Shade F (001 SSHA)	■	■	■

4461/S

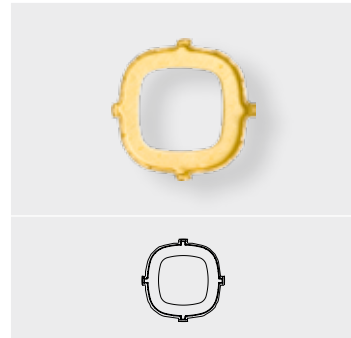

Ring/Hole, Back Configuration	8 mm	12 mm	16 mm
00 C = No ring/hole, closed	■	■	■
H2 O = 4 holes/2 each side, open	■	■	■

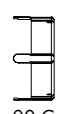

00 C

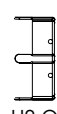

H2 O

Fancy Stones & Settings

4470



Size	10 mm	12 mm	18 mm

Crystal

- Crystal (001)
- Crystal F (001)

Colors

Plain Colors

- Aquamarine F (202)
- Black Diamond F (215)
- Burgundy F (515)
- Chrysolite F (238)
- Dark Moss Green F (260)
- Denim Blue F (266)
- Erinite F (360)
- Fern Green F (291)
- Greige F (284)
- Indian Pink F (289)
- Jet (280)
- Indicolite F (379)
- Light Azore F (361)
- Light Colorado Topaz F (246)
- Light Peach F (362)
- Light Silk F (261)
- Light Smoked Topaz F (221)
- Light Turquoise F (263)
- Padparadscha F (542)
- Provence Lavender (283)
- Provence Lavender F (283)
- Purple Velvet F (277)
- Rosaline F (508)
- Rose Peach F (262)
- Siam F (208)
- Smoked Topaz F (220)
- Smoky Quartz F (225)
- Tangerine F (259)
- Tanzanite F (539)
- Vintage Rose F (319)
- Violet F (371)

Opal Colors

- Air Blue Opal F (285)
- Chrysolite Opal F (294)
- Pacific Opal F (390)
- Palace Green Opal F (393)

Size	10 mm	12 mm	18 mm
Crystal (001)			
Crystal F (001)			
Aquamarine F (202)			
Black Diamond F (215)			
Burgundy F (515)			
Chrysolite F (238)			
Dark Moss Green F (260)			
Denim Blue F (266)			
Erinite F (360)			
Fern Green F (291)			
Greige F (284)			
Indian Pink F (289)			
Jet (280)			
Indicolite F (379)			
Light Azore F (361)			
Light Colorado Topaz F (246)			
Light Peach F (362)			
Light Silk F (261)			
Light Smoked Topaz F (221)			
Light Turquoise F (263)			
Padparadscha F (542)			
Provence Lavender (283)			
Provence Lavender F (283)			
Purple Velvet F (277)			
Rosaline F (508)			
Rose Peach F (262)			
Siam F (208)			
Smoked Topaz F (220)			
Smoky Quartz F (225)			
Tangerine F (259)			
Tanzanite F (539)			
Vintage Rose F (319)			
Violet F (371)			
Air Blue Opal F (285)			
Chrysolite Opal F (294)			
Pacific Opal F (390)			
Palace Green Opal F (393)			



Size	10 mm	12 mm	18 mm

- Rose Water Opal F (395)
- White Opal F (234)

Crystal Effects

Transparent Effects

- Crystal Antique Pink F (001 ANTP)
- Crystal Astral Pink F (001 API)
- Crystal Blue Shade F (001 BLSH)
- Crystal Golden Shadow (001 GSHA)
- Crystal Golden Shadow F (001 GSHA)
- Crystal Lilac Shadow F (001 LISH)
- Crystal Luminous Green (001 LUMG)
- Crystal Luminous Green F (001 LUMG)
- Crystal Moonlight F (001 MOL)
- Crystal Silver Night F (001 SINI)
- Crystal Silver Shade (001 SSHA)
- Crystal Silver Shade F (001 SSHA)

Metallic Effects

- Crystal Iridescent Green F (001 IRIG)
- Crystal Rose Gold F (001 ROGL)

Crystal Patina

- Crystal Black Patina F (001 BLAPA)
- Crystal Gold Patina F (001 GOLPA)
- Crystal Rose Patina F (001 ROSPA)
- Crystal Silver Patina F (001 SILPA)
- Crystal White Patina F (001 WHIPA)

Size	10 mm	12 mm	18 mm
Rose Water Opal F (395)			
White Opal F (234)			
Crystal Antique Pink F (001 ANTP)			
Crystal Astral Pink F (001 API)			
Crystal Blue Shade F (001 BLSH)			
Crystal Golden Shadow (001 GSHA)			
Crystal Golden Shadow F (001 GSHA)			
Crystal Lilac Shadow F (001 LISH)			
Crystal Luminous Green (001 LUMG)			
Crystal Luminous Green F (001 LUMG)			
Crystal Moonlight F (001 MOL)			
Crystal Silver Night F (001 SINI)			
Crystal Silver Shade (001 SSHA)			
Crystal Silver Shade F (001 SSHA)			
Crystal Iridescent Green F (001 IRIG)			
Crystal Rose Gold F (001 ROGL)			
Crystal Black Patina F (001 BLAPA)			
Crystal Gold Patina F (001 GOLPA)			
Crystal Rose Patina F (001 ROSPA)			
Crystal Silver Patina F (001 SILPA)			
Crystal White Patina F (001 WHIPA)			

Fancy Stones & Settings

4470/S

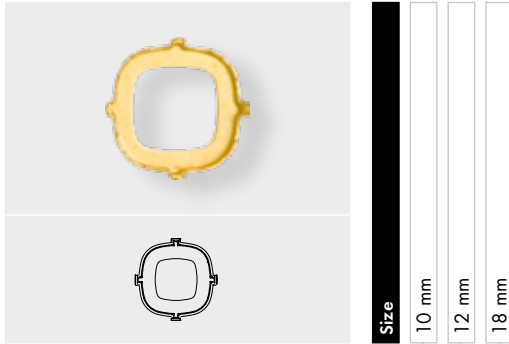

Ring/Hole, Back Configuration

- 00 C = No ring/hole, closed
- H2 O = 4 holes/2 each side, open



Size
10 mm
12 mm
18 mm

4500

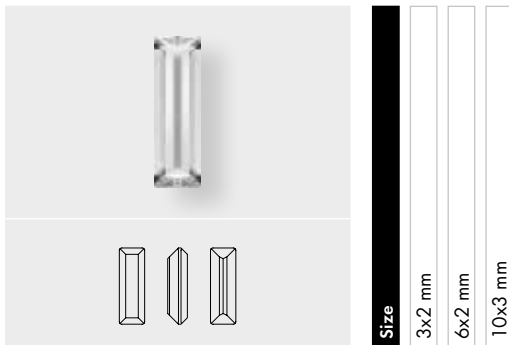

Crystal

- Crystal F (001)

Colors

Plain Colors

- Amethyst F (204)
- Aquamarine F (202)
- Black Diamond F (215)
- Jet (280)
- Jonquil F (213)
- Light Amethyst F (212)
- Light Rose F (223)
- Light Sapphire F (211)
- Light Siam F (227)
- Light Smoked Topaz F (221)
- Montana F (207)
- Rose F (209)
- Rose Peach F (262)
- Smoked Topaz F (220)
- Topaz F (203)

Size
3x2 mm
6x2 mm
10x3 mm

4500/S

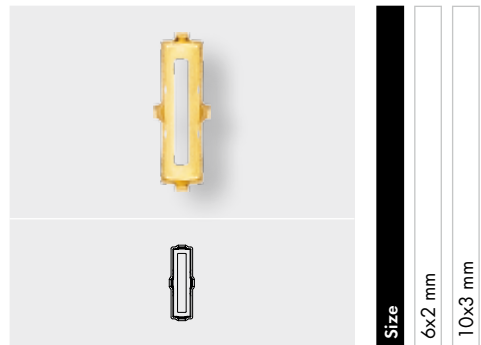

Ring/Hole, Back Configuration

- 00 C = No ring/hole, closed
- H2 O = 4 holes/2 each side, open



Size
6x2 mm
10x3 mm

Fancy Stones & Settings

4501

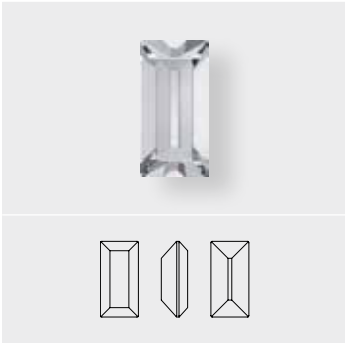

Size	4x2 mm	5x2 mm	5x2.5 mm	7x3 mm	10x5 mm
------	--------	--------	----------	--------	---------

Crystal

Crystal F (001)	■	■	■	■	■
-----------------	---	---	---	---	---

Colors

Plain Colors

Amethyst F (204)	■	■	■	■	■
Aquamarine F (202)	■	■	■	■	■
Black Diamond F (215)	■	■	■	■	■
Emerald F (205)	■	■	■	■	■
Erinite F (360)	■	■	■	■	■
Fuchsia F (502)	■	■	■	■	■
Indian Siam F (327)	■	■	■	■	■
Jet (280)	■	■	■	■	■
Light Amethyst F (212)	■	■	■	■	■
Light Peach F (362)	■	■	■	■	■
Light Rose F (223)	■	■	■	■	■
Light Sapphire F (211)	■	■	■	■	■
Light Smoked Topaz F (221)	■	■	■	■	■
Montana F (207)	■	■	■	■	■
Peridot F (214)	■	■	■	■	■
Rose F (209)	■	■	■	■	■
Sapphire F (206)	■	■	■	■	■
Siam F (208)	■	■	■	■	■
Smoked Topaz F (220)	■	■	■	■	■
Tanzanite F (539)	■	■	■	■	■
Topaz F (203)	■	■	■	■	■
Violet F (371)	■	■	■	■	■

Crystal Effects

Transparent Effects

Crystal AB F (001 AB)	■	■	■	■	■
Crystal Golden Shadow F (001 GSHA)	■	■	■	■	■

Metallic Effects

Crystal Rose Gold F (001 ROGL)	■	■	■	■	■
--------------------------------	---	---	---	---	---

4501/S

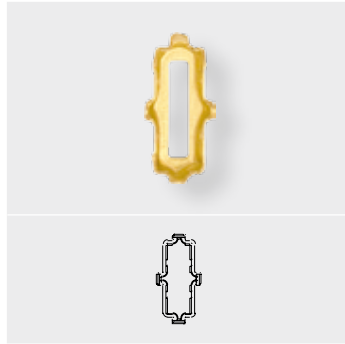

Size	5x2.5 mm	7x3 mm	10x5 mm
------	----------	--------	---------

Ring/Hole, Back Configuration

00 C = No ring/hole, closed	■	■	■
H2 O = 4 holes/2 each side, open	■	■	■

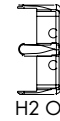
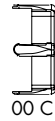

Fancy Stones & Settings

4502

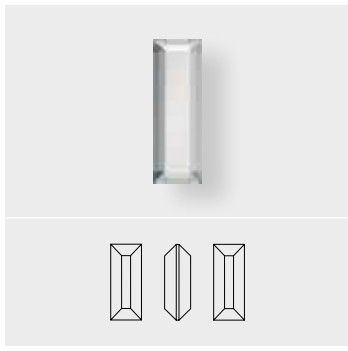

Size
3x1 mm

Crystal
Crystal F (001)

4505 Contour Baguette Fancy Stone



Size
8x5 mm
10x6 mm
14x8 mm

Crystal
Crystal F (001)

Crystal Effects

Transparent Effects
Crystal Golden Shadow F (001 GSHA)

4505/S

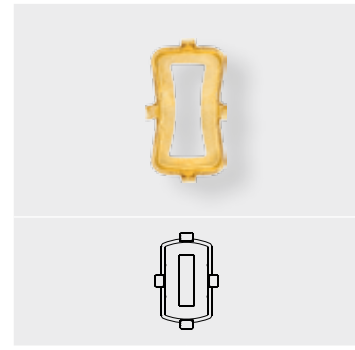

Size
8x5 mm
10x6 mm
14x8 mm

Ring/Hole, Back Configuration
00 C = No ring/hole, closed
H2 O = 4 holes/2 each side, open

00 C H2 O

Fancy Stones & Settings

4524 Pure Baguette Fancy Stone

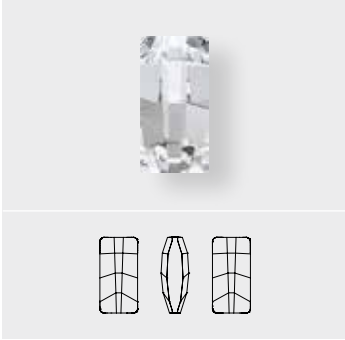

Size 12x6 mm

4524 Pure Baguette Fancy Stone

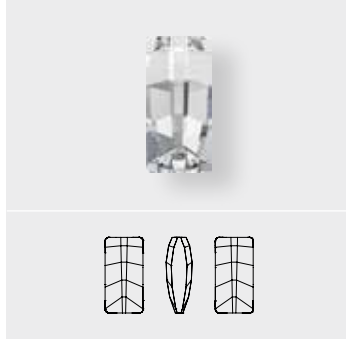

Size 16x8, 23x11 mm

4524	Size	12x6 mm	16x8 mm	23x11 mm
Crystal				
<input type="checkbox"/> Crystal F (001)		<input type="checkbox"/>	<input type="checkbox"/>	<input type="checkbox"/>
Colors				
Plain Colors				
<input type="checkbox"/> Amethyst F (204)		<input type="checkbox"/>	<input type="checkbox"/>	<input type="checkbox"/>
<input type="checkbox"/> Emerald F (205)		<input type="checkbox"/>	<input type="checkbox"/>	<input type="checkbox"/>
<input type="checkbox"/> Jet (280)		<input type="checkbox"/>	<input type="checkbox"/>	<input type="checkbox"/>
<input type="checkbox"/> Light Colorado Topaz F (246)		<input type="checkbox"/>	<input type="checkbox"/>	<input type="checkbox"/>
<input type="checkbox"/> Peridot F (214)		<input type="checkbox"/>	<input type="checkbox"/>	<input type="checkbox"/>
Crystal Effects				
Transparent Effects				
<input type="checkbox"/> Crystal AB F (001 AB)		<input type="checkbox"/>	<input type="checkbox"/>	<input type="checkbox"/>
<input type="checkbox"/> Crystal Blue Shade F (001 BLSH)		<input type="checkbox"/>	<input type="checkbox"/>	<input type="checkbox"/>
<input type="checkbox"/> Crystal Golden Shadow F (001 GSHA)		<input type="checkbox"/>	<input type="checkbox"/>	<input type="checkbox"/>
<input type="checkbox"/> Crystal Luminous Green F (001 LUMG)		<input type="checkbox"/>	<input type="checkbox"/>	<input type="checkbox"/>
<input type="checkbox"/> Crystal Red Magma F (001 REDM)		<input type="checkbox"/>	<input type="checkbox"/>	<input type="checkbox"/>
<input type="checkbox"/> Crystal Silver Shade F (001 SSHA)		<input type="checkbox"/>	<input type="checkbox"/>	<input type="checkbox"/>

4524/S

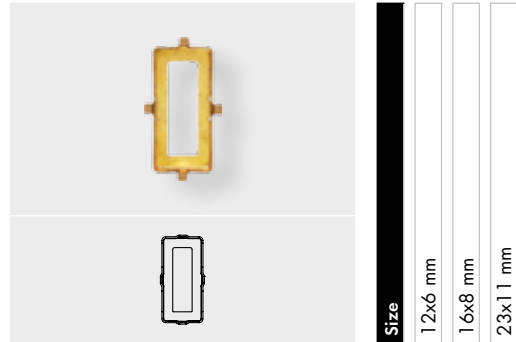

Ring/Hole, Back Configuration

00 C = No ring/hole, closed

H2 O = 4 holes/2 each side, open

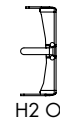
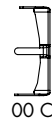

Size	12x6 mm	16x8 mm	23x11 mm
<input type="checkbox"/> 00 C	<input type="checkbox"/>	<input type="checkbox"/>	<input type="checkbox"/>
<input type="checkbox"/> H2 O	<input type="checkbox"/>	<input type="checkbox"/>	<input type="checkbox"/>

Fancy Stones & Settings

4527 Step Cut Fancy Stone

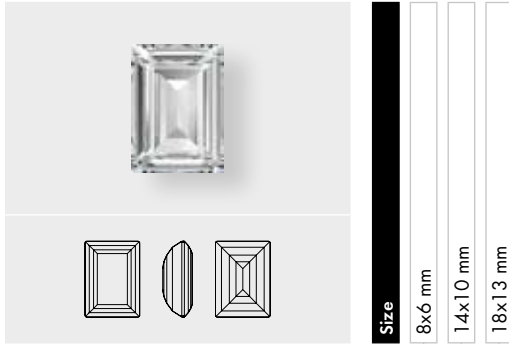

Crystal	8x6 mm	14x10 mm	18x13 mm
Crystal F (001)	■	■	■
Colors			
Plain Colors			
Erinite F (360)	■	■	■
Light Amethyst F (212)	■	■	■
Montana F (207)	■	■	■
Smoky Quartz F (225)	■	■	■
Tanzanite F (539)	■	■	■
Crystal Effect			
Transparent Effects			
Crystal Golden Shadow F (001 GSHA)	■	■	■

4527/S

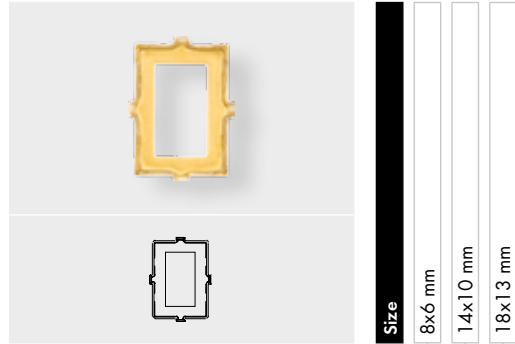

Ring/Hole, Back Configuration	8x6 mm	14x10 mm	18x13 mm
00 C = No ring/hole, closed	■	■	■
H2 O = 4 holes/2 each side, open	■	■	■

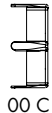

00 C

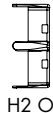

H2 O

4547 Princess Baguette Fancy Stone

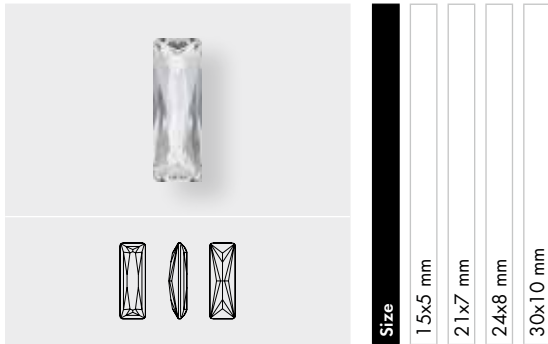

Crystal	15x5 mm	21x7 mm	24x8 mm	30x10 mm
Crystal F (001)	■	■	■	■
Colors				
Plain Colors				
Aquamarine F (202)	■	■	■	■
Black Diamond F (215)	■	■	■	■
Burgundy F (515)	■	■	■	■
Erinite F (360)	■	■	■	■
Jet (280)	■	■	■	■
Light Rose F (223)	■	■	■	■
Light Smoked Topaz F (221)	■	■	■	■
Tanzanite F (539)	■	■	■	■
Crystal Effects				
Transparent Effects				
Crystal Golden Shadow F (001 GSHA)	■	■	■	■
Crystal Silver Shade F (001 SSHA)	■	■	■	■

4547/S

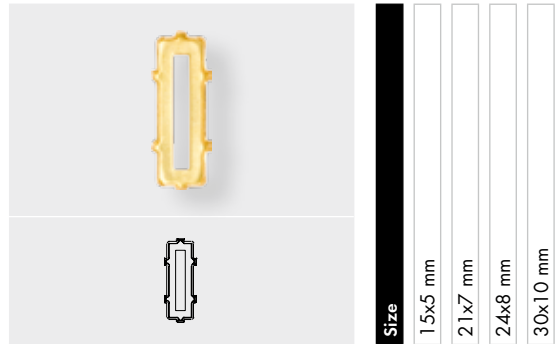

Ring/Hole, Back Configuration	15x5 mm	21x7 mm	24x8 mm	30x10 mm
00 C = No ring/hole, closed	■	■	■	■
H2 O = 4 holes/2 each side, open	■	■	■	■

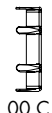

00 C

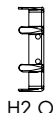

H2 O

Fancy Stones & Settings

4565 Classical Baguette Fancy Stone

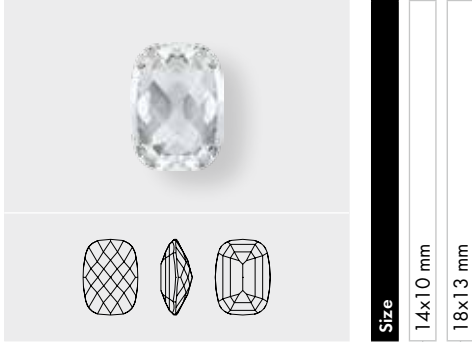

Size

14x10 mm

18x13 mm

Crystal

Crystal F (001)

Colors

Plain Colors

Aquamarine F (202)

Tanzanite (539)

Tanzanite F (539)

Crystal Effects

Transparent Effects

Crystal Golden Shadow F (001 GSHA)

4565/S

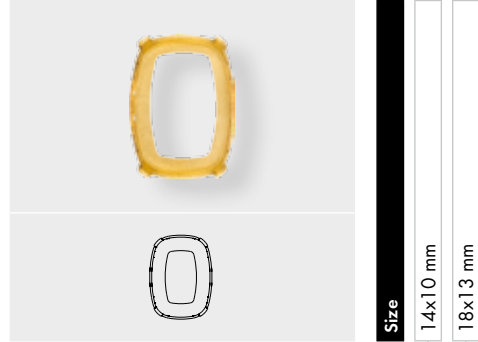

Size

14x10 mm

18x13 mm

Ring/Hole, Back Configuration

00 C = No ring/hole, closed

H2 O = 4 holes/2 each side, open



00 C



H2 O

Fancy Stones & Settings

4568 Cushion Fancy Stone

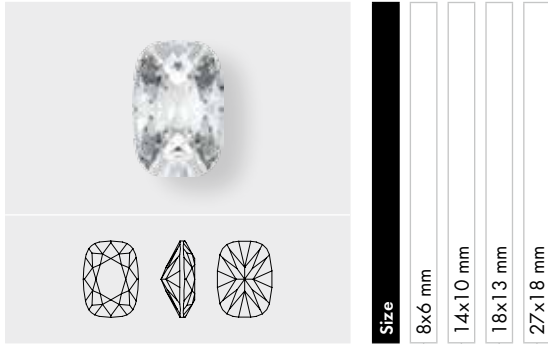

	8x6 mm	14x10 mm	18x13 mm	27x18 mm
Crystal				
Crystal F (001)	■	■	■	■
Colors				
Plain Colors				
Aquamarine F (202)	■	■	■	■
Dark Moss Green F (260)	■	■	■	■
Denim Blue F (266)	■	■	■	■
Jet (280)	■	■	■	■
Light Colorado Topaz F (246)	■	■	■	■
Light Siam F (227)	■	■	■	■
Rose F (209)	■	■	■	■
Tanzanite F (539)	■	■	■	■
Crystal Effects				
Transparent Effects				
Crystal AB F (001 AB)	■	■	■	■
Crystal Antique Pink F (001 ANTP)	■	■	■	■
Crystal Golden Shadow F (001 GSHA)	■	■	■	■
Crystal Lilac Shadow F (001 LISH)	■	■	■	■
Crystal Luminous Green F (001 LUMG)	■	■	■	■
Crystal Silver Night (001 SINI)	■	■	■	■
Crystal Silver Shade F (001 SSHA)	■	■	■	■
Metallic Effects				
Crystal Iridescent Green F (001 IRIG)	■	■	■	■
Crystal Patina				
Crystal Black Patina F (001 BLAPA)	■	■	■	■
Crystal Gold Patina F (001 GOLPA)	■	■	■	■
Crystal Rose Patina F (001 ROSPA)	■	■	■	■
Crystal Silver Patina F (001 SILPA)	■	■	■	■
Crystal White Patina F (001 WHIPA)	■	■	■	■

4568/S

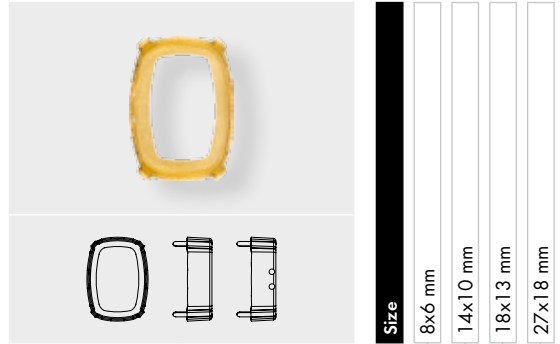

	8x6 mm	14x10 mm	18x13 mm	27x18 mm
Ring/Hole, Back Configuration				
00 C = No ring/hole, closed	■	■	■	■
H2 O = 4 holes/2 each side, open	■	■	■	■



Fancy Stones & Settings

4600



Crystal	6x4 mm	8x6 mm	10x8 mm	12x10 mm
Crystal F (001)	■	■	■	■
Colors				
Plain Colors				
Jet (280)	■	■	■	■
Montana F (207)	■	■	■	■
Rose F (209)	■	■	■	■
Crystal Effects				
Transparent Effects				
Crystal Golden Shadow F (001 GSHA)	■	■	■	■
Crystal Silver Shade F (001 SSHA)	■	■	■	■

4600/S

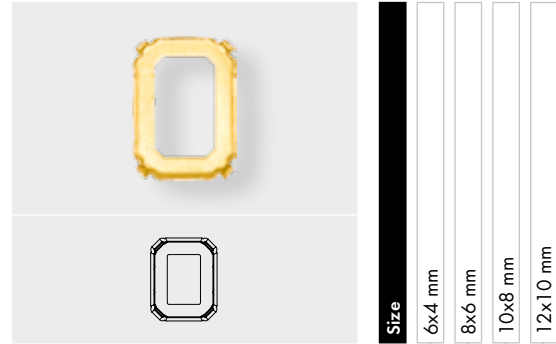

Ring/Hole, Back Configuration	6x4 mm	8x6 mm	10x8 mm	12x10 mm
00 C = No ring/hole, closed	■	■	■	■
H2 O = 4 holes/2 each side, open	■	■	■	■

00 C

H2 O

Fancy Stones & Settings

4610



Crystal	14x10 mm	18x13 mm	20x15 mm
Crystal F (001)	<input checked="" type="checkbox"/>	<input checked="" type="checkbox"/>	<input checked="" type="checkbox"/>
Colors			
Plain Colors			
Amethyst F (204)	<input checked="" type="checkbox"/>	<input checked="" type="checkbox"/>	<input checked="" type="checkbox"/>
Aquamarine F (202)	<input checked="" type="checkbox"/>	<input checked="" type="checkbox"/>	<input checked="" type="checkbox"/>
Black Diamond F (215)	<input checked="" type="checkbox"/>	<input checked="" type="checkbox"/>	<input checked="" type="checkbox"/>
Dark Moss Green F (260)	<input checked="" type="checkbox"/>	<input checked="" type="checkbox"/>	<input checked="" type="checkbox"/>
Emerald F (205)	<input checked="" type="checkbox"/>	<input checked="" type="checkbox"/>	<input checked="" type="checkbox"/>
Jet (280)	<input checked="" type="checkbox"/>	<input checked="" type="checkbox"/>	<input checked="" type="checkbox"/>
Light Colorado Topaz F (246)	<input checked="" type="checkbox"/>	<input checked="" type="checkbox"/>	<input checked="" type="checkbox"/>
Montana F (207)	<input checked="" type="checkbox"/>	<input checked="" type="checkbox"/>	<input checked="" type="checkbox"/>
Peridot F (214)	<input checked="" type="checkbox"/>	<input checked="" type="checkbox"/>	<input checked="" type="checkbox"/>
Siam F (208)	<input checked="" type="checkbox"/>	<input checked="" type="checkbox"/>	<input checked="" type="checkbox"/>
Tanzanite F (539)	<input checked="" type="checkbox"/>	<input checked="" type="checkbox"/>	<input checked="" type="checkbox"/>
Topaz F (203)	<input checked="" type="checkbox"/>	<input checked="" type="checkbox"/>	<input checked="" type="checkbox"/>
Crystal Effects			
Transparent Effects			
Crystal Golden Shadow F (001 GSHA)	<input checked="" type="checkbox"/>	<input checked="" type="checkbox"/>	<input checked="" type="checkbox"/>
Crystal Silver Shade F (001 SSHA)	<input checked="" type="checkbox"/>	<input checked="" type="checkbox"/>	<input checked="" type="checkbox"/>

4610/S

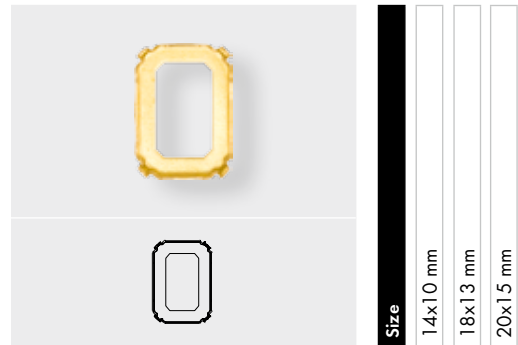

Ring/Hole, Back Configuration	14x10 mm	18x13 mm	20x15 mm
00 C = No ring/hole, closed	<input checked="" type="checkbox"/>	<input checked="" type="checkbox"/>	<input checked="" type="checkbox"/>
H2 O = 4 holes/2 each side, open	<input checked="" type="checkbox"/>	<input checked="" type="checkbox"/>	<input checked="" type="checkbox"/>

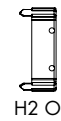
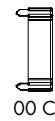

Fancy Stones & Settings

4627

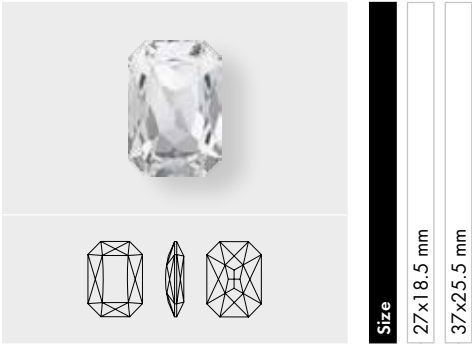

- Crystal**
- Crystal F (001)
- Colors**
- Plain Colors**
- Amethyst F (204)
- Aquamarine F (202)
- Black Diamond F (215)
- Burgundy F (515)
- Dark Moss Green F (260)
- Emerald F (205)
- Jet (280)
- Light Colorado Topaz F (246)
- Montana F (207)
- Tanzanite F (539)
- Crystal Effects**
- Transparent Effects**
- Crystal AB F (001 AB)
- Crystal Golden Shadow F (001 GSHA)
- Crystal Moonlight F (001 MOL)
- Crystal Red Magma F (001 REDM)
- Crystal Silver Shade F (001 SSHA)
- Crystal Vitrail Medium (001 VM)
- Color Effect**
- Metallic Effects**
- Jet Hematite (280 HEM)

4627/S

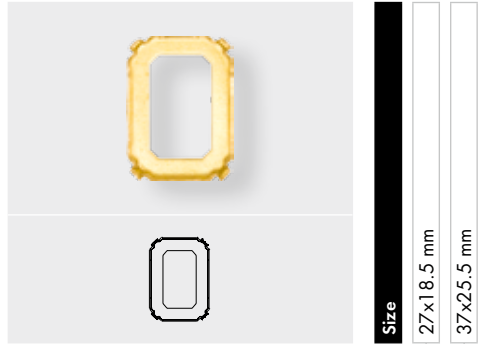

- Ring/Hole, Back Configuration**
- 00 C = No ring/hole, closed
- H2 O = 4 holes/2 each side, open



Fancy Stones & Settings

4675



Size
23 mm

Crystal

Crystal F (001)

Crystal Effects

Transparent Effects

Crystal Golden Shadow F (001 GSHA)

Crystal Silver Shade F (001 SSHA)

4675/S

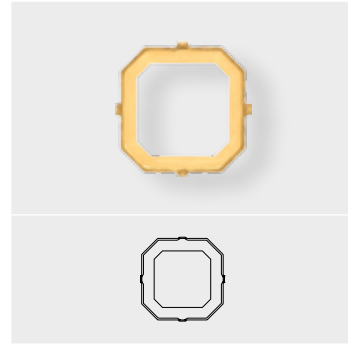

Size
23 mm

Ring/Hole, Back Configuration

00 C = No ring/hole, closed

H2 O = 4 holes/2 each side, open

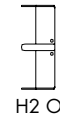

Fancy Stones & Settings

4678 Solaris Fancy Stone

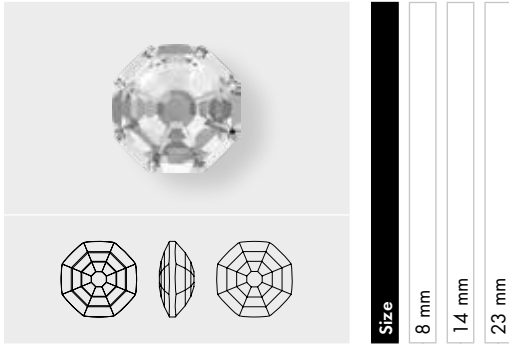

Crystal	8 mm	14 mm	23 mm
Crystal F (001)	<input checked="" type="checkbox"/>	<input checked="" type="checkbox"/>	<input checked="" type="checkbox"/>
Colors			
Plain Colors			
Aquamarine F (202)	<input checked="" type="checkbox"/>	<input checked="" type="checkbox"/>	<input checked="" type="checkbox"/>
Dark Moss Green F (260)	<input checked="" type="checkbox"/>	<input checked="" type="checkbox"/>	<input checked="" type="checkbox"/>
Jet (280)	<input checked="" type="checkbox"/>	<input checked="" type="checkbox"/>	<input checked="" type="checkbox"/>
Crystal Effects			
Transparent Effects			
Crystal AB F (001 AB)	<input checked="" type="checkbox"/>	<input checked="" type="checkbox"/>	<input checked="" type="checkbox"/>
Crystal Antique Pink F (001 ANTP)	<input checked="" type="checkbox"/>	<input checked="" type="checkbox"/>	<input checked="" type="checkbox"/>
Crystal Golden Shadow F (001 GSHA)	<input checked="" type="checkbox"/>	<input checked="" type="checkbox"/>	<input checked="" type="checkbox"/>
Crystal Lilac Shadow F (001 LISH)	<input checked="" type="checkbox"/>	<input checked="" type="checkbox"/>	<input checked="" type="checkbox"/>
Crystal Luminous Green F (001 LUMG)	<input checked="" type="checkbox"/>	<input checked="" type="checkbox"/>	<input checked="" type="checkbox"/>
Crystal Red Magma F (001 REDM)	<input checked="" type="checkbox"/>	<input checked="" type="checkbox"/>	<input checked="" type="checkbox"/>
Crystal Silver Night (001 SINI)	<input checked="" type="checkbox"/>	<input checked="" type="checkbox"/>	<input checked="" type="checkbox"/>
Metallic Effects			
Crystal Iridescent Green F (001 IRIG)	<input checked="" type="checkbox"/>	<input checked="" type="checkbox"/>	<input checked="" type="checkbox"/>

4678/G Solaris Fancy Stone partly frosted

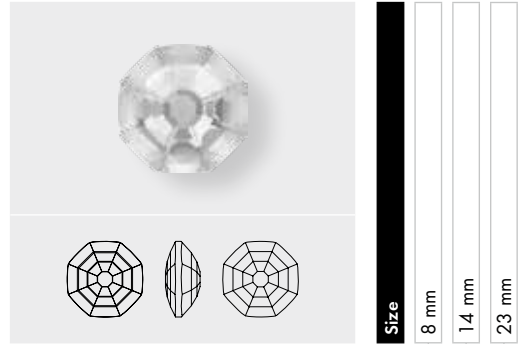

Crystal	8 mm	14 mm	23 mm
Crystal F (001)	<input checked="" type="checkbox"/>	<input checked="" type="checkbox"/>	<input checked="" type="checkbox"/>
Colors			
Plain Colors			
Aquamarine F (202)	<input checked="" type="checkbox"/>	<input checked="" type="checkbox"/>	<input checked="" type="checkbox"/>
Dark Moss Green F (260)	<input checked="" type="checkbox"/>	<input checked="" type="checkbox"/>	<input checked="" type="checkbox"/>
Jet (280)	<input checked="" type="checkbox"/>	<input checked="" type="checkbox"/>	<input checked="" type="checkbox"/>
Crystal Effects			
Transparent Effects			
Crystal AB F (001 AB)	<input checked="" type="checkbox"/>	<input checked="" type="checkbox"/>	<input checked="" type="checkbox"/>
Crystal Antique Pink F (001 ANTP)	<input checked="" type="checkbox"/>	<input checked="" type="checkbox"/>	<input checked="" type="checkbox"/>
Crystal Golden Shadow F (001 GSHA)	<input checked="" type="checkbox"/>	<input checked="" type="checkbox"/>	<input checked="" type="checkbox"/>
Crystal Lilac Shadow F (001 LISH)	<input checked="" type="checkbox"/>	<input checked="" type="checkbox"/>	<input checked="" type="checkbox"/>
Crystal Luminous Green F (001 LUMG)	<input checked="" type="checkbox"/>	<input checked="" type="checkbox"/>	<input checked="" type="checkbox"/>
Crystal Red Magma F (001 REDM)	<input checked="" type="checkbox"/>	<input checked="" type="checkbox"/>	<input checked="" type="checkbox"/>
Crystal Silver Night (001 SINI)	<input checked="" type="checkbox"/>	<input checked="" type="checkbox"/>	<input checked="" type="checkbox"/>
Metallic Effects			
Crystal Iridescent Green F (001 IRIG)	<input checked="" type="checkbox"/>	<input checked="" type="checkbox"/>	<input checked="" type="checkbox"/>

4678/S

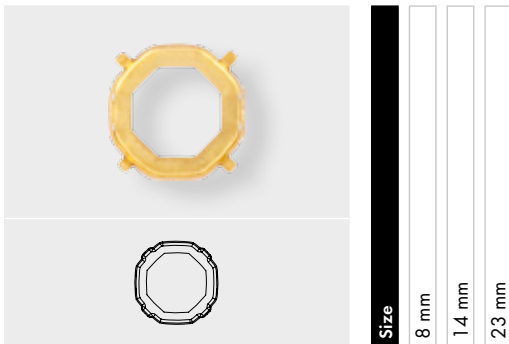

Ring/Hole, Back Configuration	8 mm	14 mm	23 mm
00 C = No ring/hole, closed	<input checked="" type="checkbox"/>	<input checked="" type="checkbox"/>	<input checked="" type="checkbox"/>
H2 O = 4 holes/2 each side, open	<input checked="" type="checkbox"/>	<input checked="" type="checkbox"/>	<input checked="" type="checkbox"/>

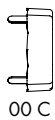

Fancy Stones & Settings

4706 Trilliant Fancy Stone

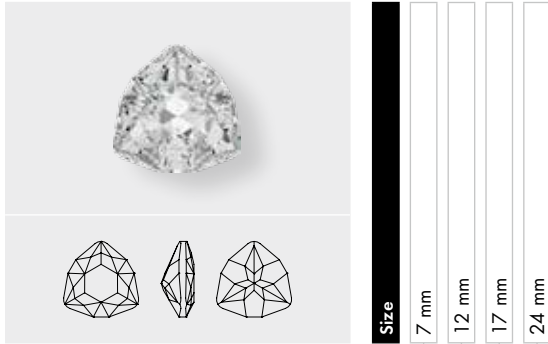

	7 mm	12 mm	17 mm	24 mm
Crystal				
Crystal F (001)	■	■	■	■
Colors				
Plain Colors				
Amethyst F (204)	■	■	■	■
Aquamarine F (202)	■	■	■	■
Dark Moss Green F (260)	■	■	■	■
Light Colorado Topaz F (246)	■	■	■	■
Padparadscha F (542)	■	■	■	■
Rose F (209)	■	■	■	■
Tanzanite F (539)	■	■	■	■
Vintage Rose F (319)	■	■	■	■
Crystal Effects				
Transparent Effects				
Crystal AB F (001 AB)	■	■	■	■
Crystal Blue Shade F (001 BLSH)	■	■	■	■
Crystal Golden Shadow F (001 GSHA)	■	■	■	■
Crystal Luminous Green F (001 LUMG)	■	■	■	■
Crystal Silver Night (001 SINI)	■	■	■	■
Crystal Silver Shade F (001 SSHA)	■	■	■	■
Crystal Patina				
Crystal Black Patina F (001 BLAPA)	■	■	■	■
Crystal Gold Patina F (001 GOLPA)	■	■	■	■
Crystal Rose Patina F (001 ROSPA)	■	■	■	■
Crystal Silver Patina F (001 SILPA)	■	■	■	■
Crystal White Patina F (001 WHIPA)	■	■	■	■

4706/S



	7 mm	12 mm	17 mm	24 mm
Ring/Hole, Back Configuration				
00 C = No ring/hole, closed	■	■	■	■
H2 O = 4 holes/2 each side, open	■	■	■	■



00 C



H2 O

Fancy Stones & Settings

4717 Delta Fancy Stone



Size

15.5 mm

21.5 mm

Crystal

Crystal F (001)

Colors

Plain Colors

Aquamarine F (202)

Black Diamond F (215)

Denim Blue F (266)

Montana F (207)

Tanzanite F (539)

Crystal Effects

Transparent Effects

Crystal Antique Pink F (001 ANTP)

Crystal Astral Pink F (001 API)

Crystal Golden Shadow F (001 GSHA)

Crystal Red Magma F (001 REDM)

Crystal Silver Shade F (001 SSHA)

4717/S

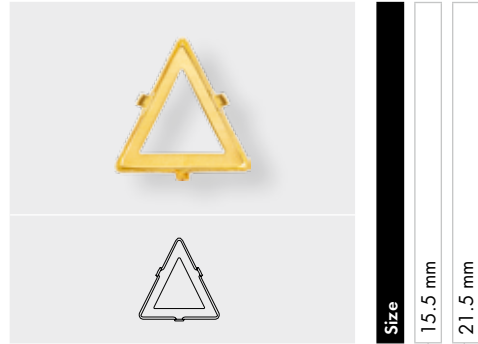

Size

15.5 mm

21.5 mm

Ring/Hole, Back Configuration

00 C = No ring/hole, closed

H2 O = 4 holes/2 each side, open

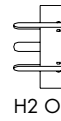
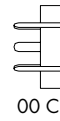

Fancy Stones & Settings

4722

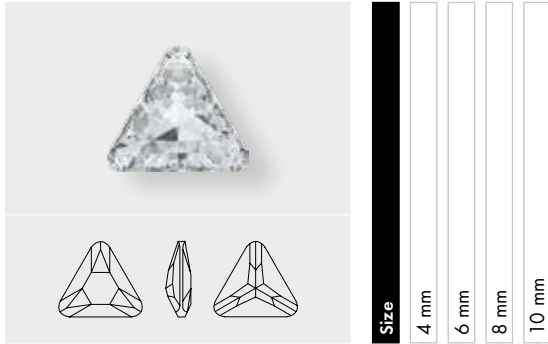

Crystal

Crystal F (001)

- Size**
- 4 mm
 - 6 mm
 - 8 mm
 - 10 mm

4722/S



Ring/Hole, Back Configuration

00 C = No ring/hole, closed

H2 O = 4 holes/2 each side, open

- Size**
- 4 mm
 - 6 mm
 - 8 mm
 - 10 mm



00 C



H2 O

Fancy Stones & Settings

4727



Size

23 mm

Crystal

Crystal F (001)

Crystal Effects

Transparent Effects

Crystal Golden Shadow F (001 GSHA)

Crystal Silver Shade F (001 SSHA)

4727/S

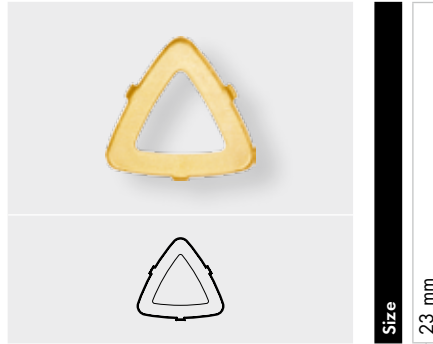

Size

23 mm

Ring/Hole, Back Configuration

00 C = No ring/hole, closed

H2 O = 4 holes/2 each side, open

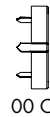

00 C



H2 O

4739 Cosmic Fancy Stone

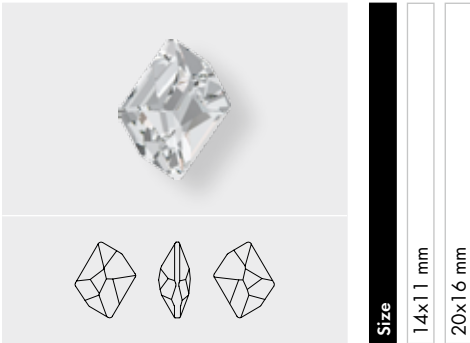

Size

14x11 mm

20x16 mm

Crystal

Crystal F (001)

Colors

Plain Colors

Aquamarine F (202)

Light Amethyst F (212)

Rose F (209)

Crystal Effects

Transparent Effects

Crystal Golden Shadow F (001 GSHA)

Crystal Silver Shade F (001 SSHA)

4739/S

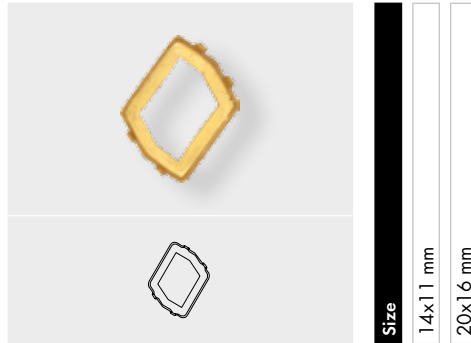

Size

14x11 mm

20x16 mm

Ring/Hole, Back Configuration

00 C = No ring/hole, closed

H2 O = 4 holes/2 each side, open



00 C



H2 O

Fancy Stones & Settings

4744 Rivoli Flower Fancy Stone

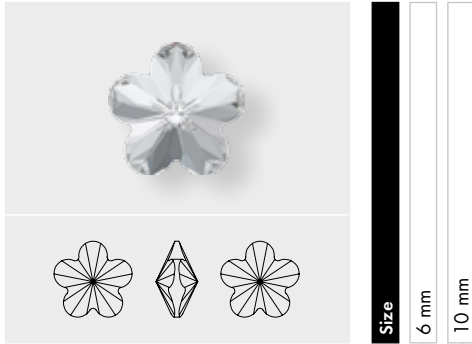

Size
6 mm
10 mm

Crystal

Crystal F (001)

Colors

Plain Colors

Aquamarine F (202)

Fuchsia F (502)

Light Rose F (223)

Light Siam F (227)

Peridot F (214)

Violet F (371)

Crystal Effects

Transparent Effects

Crystal AB F (001 AB)

Crystal Lilac Shadow F (001 LISH)

4744/S

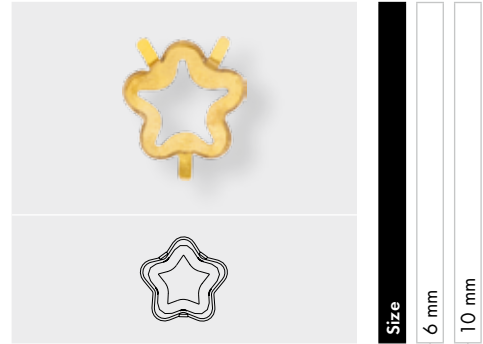

Size
6 mm
10 mm

Ring/Hole, Back Configuration

00 C = No ring/hole, closed

H2 O = 4 holes/2 each side, open

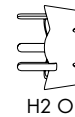

Fancy Stones & Settings

4745 Rivoli Star Fancy Stone

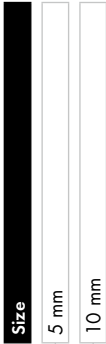

Crystal

Crystal F (001)

Colors

Plain Colors

Jet (280)

Crystal Effects

Transparent Effects

Crystal AB F (001 AB)

Crystal Bermuda Blue F (001 BBL)

Crystal Golden Shadow F (001 GSHA)

Crystal Silver Shade F (001 SSHA)

Crystal Vitrail Light F (001 VL)

Crystal Vitrail Medium F (001 VM)

Metallic Effects

Crystal Rose Gold F (001 ROGL)

Color Effects

Metallic Effects

Jet Hematite (280 HEM)

4745/S

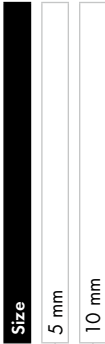
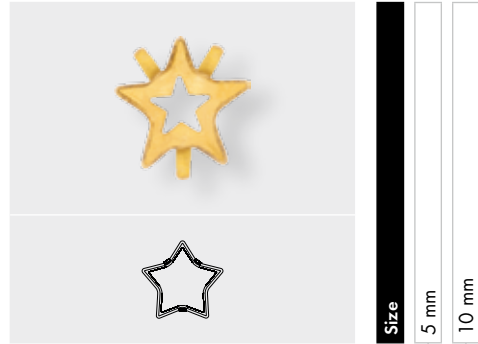

Ring/Hole, Back Configuration

00 C = No ring/hole, closed

H2 O = 4 holes/2 each side, open



Fancy Stones & Settings

4747 Rivoli Snowflake Fancy Stone

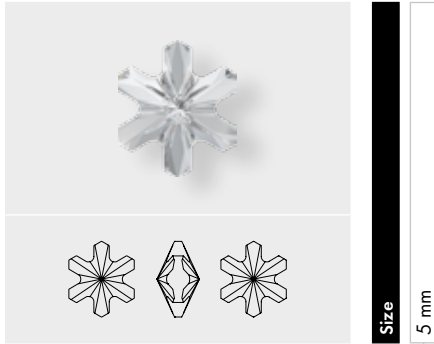

Size

5 mm

Crystal

Crystal F (001)

Colors

Plain Colors

Erinite F (360)

Indicolite F (379)

Rose Peach F (262)

Tanzanite F (539)

Crystal Effects

Transparent Effects

Crystal AB F (001 AB)

Crystal Golden Shadow F (001 GSHA)

Crystal Silver Night F (001 SINI)

Crystal Vitrail Light F (001 VL)

4747/S

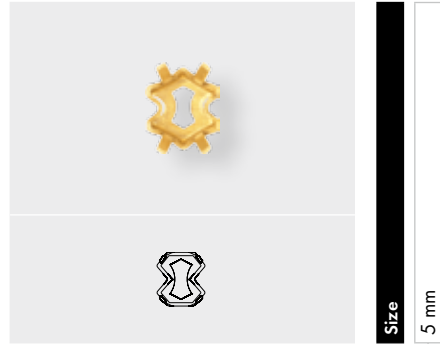

Size

5 mm

Ring/Hole, Back Configuration

00 C = No ring/hole, closed

H2 O = 4 holes/2 each side, open



00 C



H2 O

4748 Rivoli Butterfly Fancy Stone

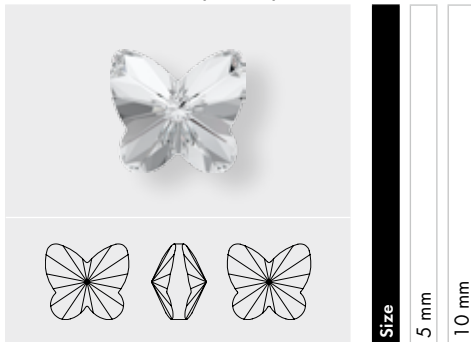

Size

5 mm

10 mm

Crystal

Crystal F (001)

Colors

Plain Colors

Aquamarine F (202)

Light Amethyst F (212)

Light Rose F (223)

Peridot F (214)

Provence Lavender F (283)

Rose Peach F (262)

Crystal Effects

Transparent Effects

Crystal Astral Pink F (001 API)

Crystal Golden Shadow F (001 GSHA)

Crystal Lilac Shadow F (001 LISH)

4748/S

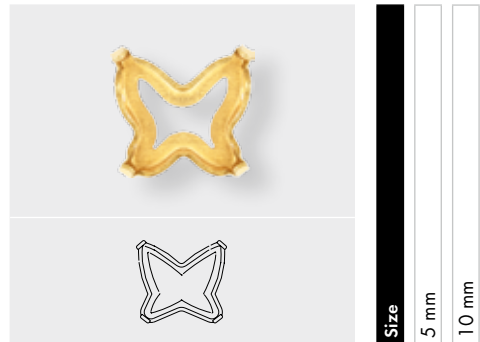

Size

5 mm

10 mm

Ring/Hole, Back Configuration

00 C = No ring/hole, closed

H2 O = 4 holes/2 each side, open



00 C



H2 O

Fancy Stones & Settings

4756 Galactic Flat Fancy Stone

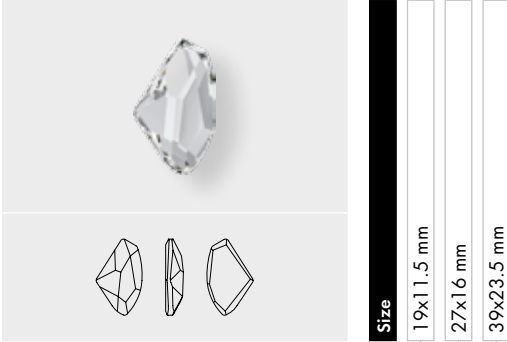

Size
 19x11.5 mm
 27x16 mm
 39x23.5 mm

- Crystal**
- Crystal F (001)
- Colors**
- Plain Colors**
- Jet (280)
- Crystal Effects**
- Transparent Effects**
- Crystal Golden Shadow F (001 GSHA)
- Crystal Silver Shade F (001 SSHA)
- Color Effects**
- Metallic Effects**
- Jet Hematite (280 HEM)

4756/S

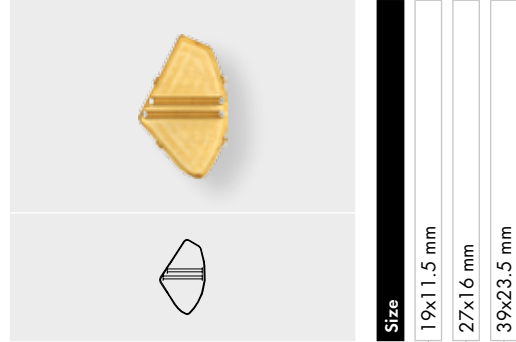

Size
 19x11.5 mm
 27x16 mm
 39x23.5 mm

- Ring/Hole, Back Configuration**
- 00 C = No ring/hole, closed
- H2 O = 4 holes/2 each side, open



4757 Galactic Fancy Stone

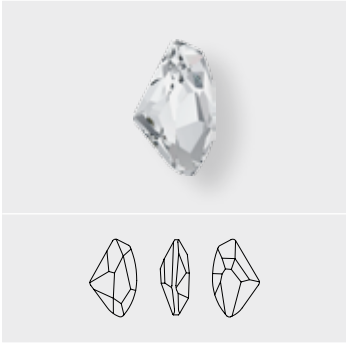

Size
 14x8.5 mm
 19x11.5 mm

- Crystal**
- Crystal F (001)
- Colors**
- Plain Colors**
- Aquamarine F (202)
- Light Rose F (223)
- Tanzanite F (539)
- Crystal Effects**
- Transparent Effects**
- Crystal Golden Shadow F (001 GSHA)

4757/S



Size
 14x8.5 mm
 19x11.5 mm

- Ring/Hole, Back Configuration**
- 00 C = No ring/hole, closed
- H2 O = 4 holes/2 each side, open



Fancy Stones & Settings

4760 Calypso Fancy Stone

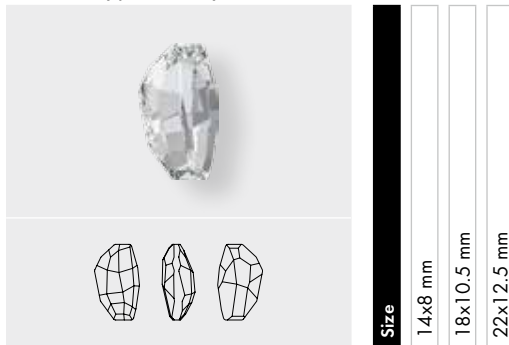

Crystal	14x8 mm	18x10.5 mm	22x12.5 mm
Crystal F (001)	<input type="checkbox"/>	<input type="checkbox"/>	<input type="checkbox"/>
Colors			
Plain Colors			
Aquamarine F (202)	<input type="checkbox"/>	<input type="checkbox"/>	<input type="checkbox"/>
Light Rose F (223)	<input type="checkbox"/>	<input type="checkbox"/>	<input type="checkbox"/>
Crystal Effects			
Transparent Effects			
Crystal Golden Shadow F (001 GSHA)	<input type="checkbox"/>	<input type="checkbox"/>	<input type="checkbox"/>
Crystal Silver Shade F (001 SSHA)	<input type="checkbox"/>	<input type="checkbox"/>	<input type="checkbox"/>

4760/S

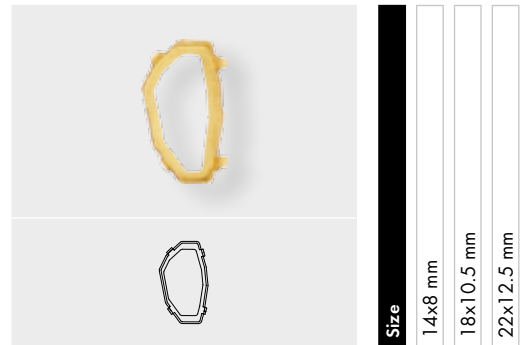

Ring/Hole, Back Configuration	14x8 mm	18x10.5 mm	22x12.5 mm
00 C = No ring/hole, closed	<input type="checkbox"/>	<input type="checkbox"/>	<input type="checkbox"/>
H2 O = 4 holes/2 each side, open	<input type="checkbox"/>	<input type="checkbox"/>	<input type="checkbox"/>

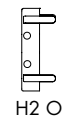
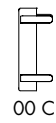

Fancy Stones & Settings

4773 Meteor Fancy Stone

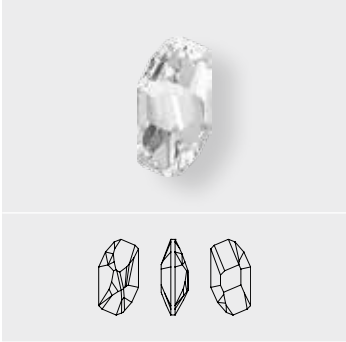

Size	14x7.5 mm	18x9.5 mm	28x15 mm
------	-----------	-----------	----------

Crystal

Crystal F (001)

Colors

Plain Colors

Black Diamond F (215)

Jet (280)

Light Turquoise F (263)

Tanzanite F (539)

Crystal Effects

Transparent Effects

Crystal AB F (001 AB)

Crystal Antique Pink F (001 ANTP)

Crystal Blue Shade F (001 BLSH)

Crystal Golden Shadow F (001 GSHA)

Crystal Luminous Green F (001 LUMG)

Crystal Red Magma F (001 REDM)

Crystal Silver Shade F (001 SSHA)

Metallic Effects

Crystal Rose Gold F (001 ROGL)

4773/S



Size	14x7.5 mm	18x9.5 mm	28x15 mm
------	-----------	-----------	----------

Ring/Hole, Back Configuration

00 C = No ring/hole, closed

H2 O = 4 holes/2 each side, open



Fancy Stones & Settings

4789 Shell Fancy Stone

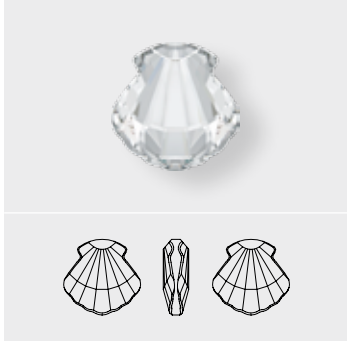

Size 14 mm

4789 Shell Fancy Stone

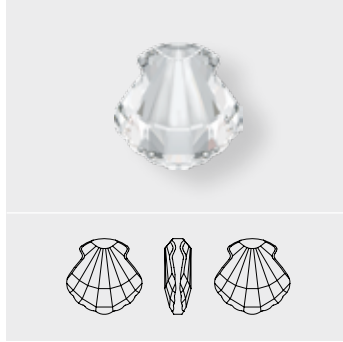

Size 23, 29 mm

4789

	Size 14 mm	23 mm	29 mm
Crystal			
Crystal F (001)	■	■	■
Colors			
Plain Colors			
Aquamarine F (202)	■	■	
Indicolite F (379)	■	■	■
Provence Lavender F (283)	■	■	
Crystal Effects			
Transparent Effects			
Crystal AB F (001 AB)	■	■	
Crystal Antique Pink F (001 ANTP)	■	■	■
Crystal Golden Shadow F (001 GSHA)	■	■	
Crystal Luminous Green F (001 LUMG)	■	■	
Crystal Red Magma F (001 REDM)	■	■	
Crystal Silver Night (001 SINI)	■	■	

4789/S

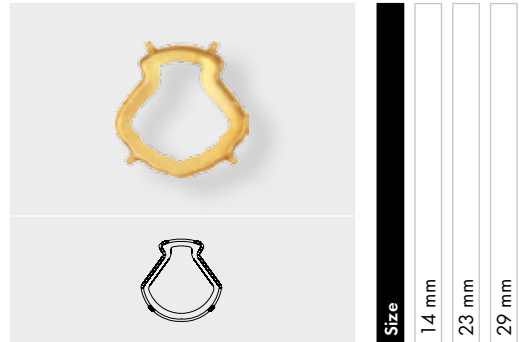

Ring/Hole, Back Configuration

00 C = No ring/hole, closed

H2 O = 4 holes/2 each side, open

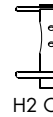

Fancy Stones & Settings

4790 Wing Fancy Stone



Size	18x7.5 mm	23x10 mm	32x13.5 mm
------	-----------	----------	------------

Crystal

Crystal F (001)

Colors

Plain Colors

Aquamarine F (202)

Fuchsia F (502)

Light Rose F (223)

Provence Lavender F (283)

Tanzanite F (539)

Crystal Effects

Transparent Effects

Crystal Astral Pink F (001 API)

Crystal Golden Shadow F (001 GSHA)

Crystal Red Magma F (001 REDM)

Crystal Silver Shade F (001 SSHA)

4790/S

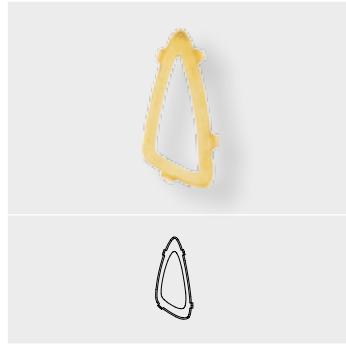

Size	18x7.5 mm	23x10 mm	32x13.5 mm
------	-----------	----------	------------

Ring/Hole, Back Configuration

00 C = No ring/hole, closed

H2 O = 4 holes/2 each side, open

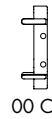

Fancy Stones & Settings

4795 Graphic Fancy Stone

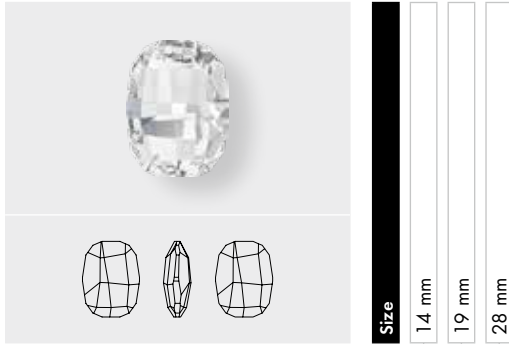

	14 mm	19 mm	28 mm
Crystal			
Crystal F (001)	■	■	■
Colors			
Plain Colors			
Amethyst F (204)	■	■	■
Aquamarine F (202)	■	■	■
Black Diamond F (215)	■	■	■
Denim Blue F (266)	■	■	■
Emerald F (205)	■	■	■
Light Amethyst F (212)	■	■	■
Crystal Effects			
Transparent Effects			
Crystal AB F (001 AB)	■	■	■
Crystal Antique Pink F (001 ANTP)	■	■	■
Crystal Astral Pink F (001 API)	■	■	■
Crystal Golden Shadow F (001 GSHA)	■	■	■
Crystal Red Magma F (001 REDM)	■	■	■
Crystal Silver Shade F (001 SSHA)	■	■	■

4795/S

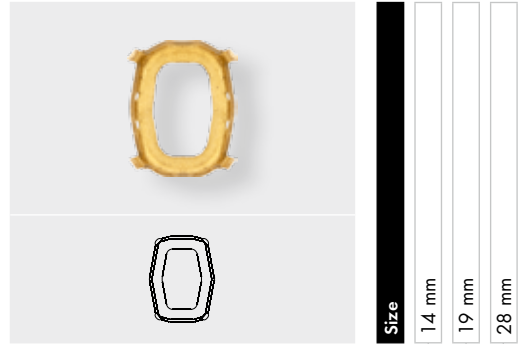

	14 mm	19 mm	28 mm
Ring/Hole, Back Configuration			
00 C = No ring/hole, closed	■	■	■
H2 O = 4 holes/2 each side, open	■	■	■

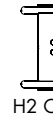
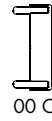

Fancy Stones & Settings

4809 Sweet Heart Fancy Stone

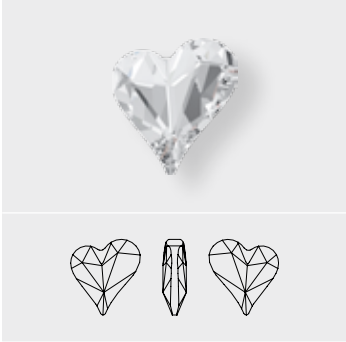

Size	13x12 mm	17x15.5 mm	27x25 mm
------	----------	------------	----------

Crystal

Crystal F (001)

Colors

Plain Colors

- Amethyst F (204)
- Erinite F (360)
- Light Siam F (227)
- Rosaline F (508)
- Rose F (209)
- Violet F (371)

Crystal Effects

Transparent Effects

- Crystal AB F (001 AB)
- Crystal Antique Pink F (001 ANTP)
- Crystal Astral Pink F (001 API)
- Crystal Blue Shade F (001 BLSH)
- Crystal Golden Shadow F (001 GSHA)
- Crystal Lilac Shadow F (001 LISH)
- Crystal Silver Night (001 SINI)
- Crystal Silver Shade F (001 SSHA)

4809/S



Size	13x12 mm	17x15.5 mm	27x25 mm
------	----------	------------	----------

Ring/Hole, Back Configuration

00 C = No ring/hole, closed

H2 O = 4 holes/2 each side, open

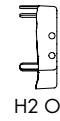
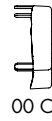

Fancy Stones & Settings

4810 Sweet Heart Fancy Stone

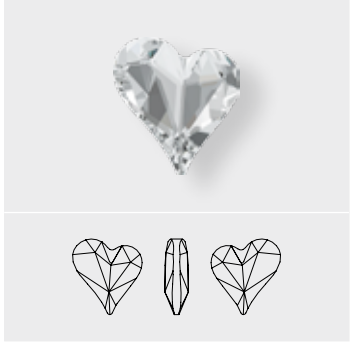

Size
13x12 mm

Crystal

Crystal F (001)

Colors

Plain Colors

Amethyst F (204)

Erinite F (360)

Light Siam F (227)

Rosaline F (508)

Rose F (209)

Violet F (371)

Crystal Effects

Transparent Effects

Crystal AB F (001 AB)

Crystal Antique Pink F (001 ANTP)

Crystal Astral Pink F (001 API)

Crystal Blue Shade F (001 BLSH)

Crystal Golden Shadow F (001 GSHA)

Crystal Lilac Shadow F (001 LISH)

Crystal Silver Night (001 SINI)

Crystal Silver Shade F (001 SSHA)

4810/S



Size
13x12 mm

Ring/Hole, Back Configuration

00 C = No ring/hole, closed

H2 O = 4 holes/2 each side, open



00 C



H2 O

Fancy Stones & Settings

4827

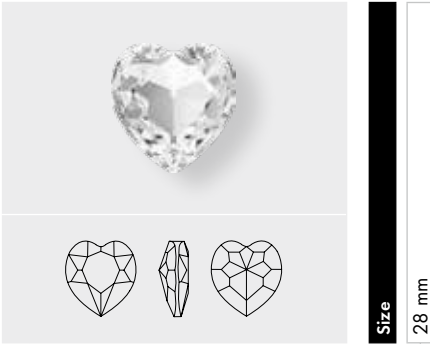

Size

28 mm

Crystal

Crystal F (001)

Colors

Plain Colors

Light Amethyst F (212)

Rosaline F (508)

Crystal Effects

Transparent Effects

Crystal AB F (001 AB)

Crystal Bermuda Blue (001 BBL)

Crystal Golden Shadow F (001 GSHA)

Crystal Silver Shade F (001 SSHA)

Crystal Vitrail Medium (001 VM)

4827/S

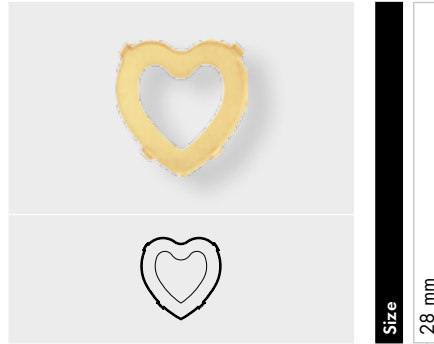

Size

28 mm

Ring/Hole, Back Configuration

00 C = No ring/hole, closed

H2 O = 4 holes/2 each side, open



00 C



H2 O

Fancy Stones & Settings

4831 Antique Heart Fancy Stone

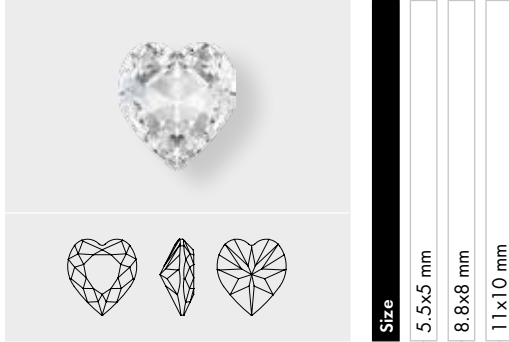

Crystal	
<input type="checkbox"/> Crystal F (001)	<input type="checkbox"/>
Colors	
Plain Colors	
<input type="checkbox"/> Light Amethyst F (212)	<input type="checkbox"/>
<input type="checkbox"/> Light Rose F (223)	<input type="checkbox"/>
<input type="checkbox"/> Rosaline F (508)	<input type="checkbox"/>
<input type="checkbox"/> Siam F (208)	<input type="checkbox"/>

Size
5.5x5 mm
8.8x8 mm
11x10 mm

4831/S

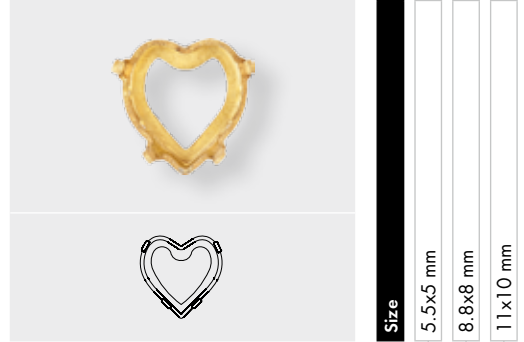

Ring/Hole, Back Configuration	
<input type="checkbox"/> 00 C = No ring/hole, closed	<input type="checkbox"/>
<input type="checkbox"/> H2 O = 4 holes/2 each side, open	<input type="checkbox"/>

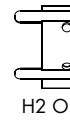
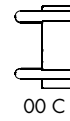

Size
5.5x5 mm
8.8x8 mm
11x10 mm

4835 Mini Heart Fancy Stone

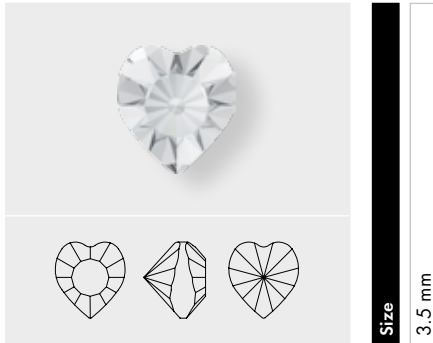

Crystal	
<input type="checkbox"/> Crystal F (001)	<input type="checkbox"/>

Size
3.5 mm

Fancy Stones & Settings

4841

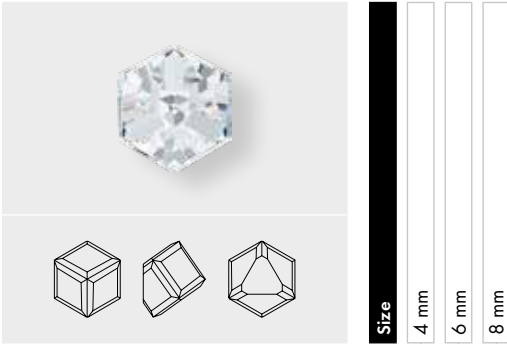

Size	4 mm	6 mm	8 mm
------	------	------	------

Crystal			
Crystal CAL VZ SI (001 CAL VZ SI)	■	■	■
Colors			
Plain Colors			
Aquamarine CAL VZ SI (202 CAL VZ SI)	■	■	■
Light Rose CAL VZ SI (223 CAL VZ SI)	■	■	■
Light Siam CAL VZ SI (227 CAL VZ SI)	■	■	■
Peridot CAL VZ SI (214 CAL VZ SI)	■	■	■
Violet CAL VZ SI (371 CAL VZ SI)	■	■	■
Crystal Effects			
Transparent Effects			
Crystal AB CAL VZ SI (001 AB CAL VZ SI)	■	■	■
Crystal Bermuda Blue Z (001 BBL Z)	■	■	■
Crystal Heliotrope Z (001 HEL Z)	■	■	■
Crystal Vitrail Light Z (001 VL Z)	■	■	■
Crystal Vitrail Medium Z (001 VM Z)	■	■	■
Crystal Golden Shadow CAL VZ SI (001 GSHA CAL VZ SI)	■	■	■

4869

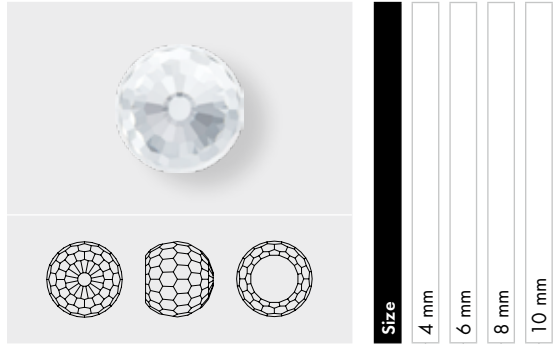

Size	4 mm	6 mm	8 mm	10 mm
------	------	------	------	-------

Crystal				
Crystal CAL VZ SI (001 CAL VZ SI)	■	■	■	■
Colors				
Plain Colors				
Aquamarine CAL VZ SI (202 CAL VZ SI)	■	■	■	■
Light Rose CAL VZ SI (223 CAL VZ SI)	■	■	■	■
Light Siam CAL VZ SI (227 CAL VZ SI)	■	■	■	■
Violet CAL VZ SI (371 CAL VZ SI)	■	■	■	■
Crystal Effects				
Transparent Effects				
Crystal AB CAL VZ SI (001 AB CAL VZ SI)	■	■	■	■
Crystal Vitrail Medium Z (001 VM Z)	■	■	■	■

Fancy Stones & Settings

4884 XILION Heart Fancy Stone

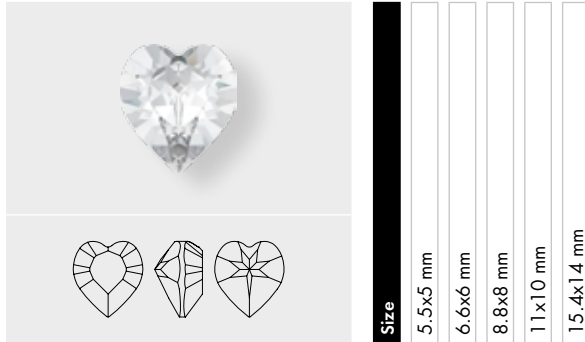

Crystal	5.5x5 mm	6.6x6 mm	8.8x8 mm	11x10 mm	15.4x14 mm
Crystal F (001)	■	■	■	■	■
Colors					
Plain Colors					
Amethyst F (204)	■	■	■	■	■
Aquamarine F (202)	■	■	■	■	■
Light Amethyst F (212)	■	■	■	■	■
Light Rose F (223)	■	■	■	■	■
Light Siam F (227)	■	■	■	■	■
Montana F (207)	■	■	■	■	■
Peridot F (214)	■	■	■	■	■
Rose F (209)	■	■	■	■	■
Rose Peach F (262)	■	■	■	■	■
Crystal Effects					
Transparent Effects					
Crystal AB F (001 AB)	■	■	■	■	■
Crystal Antique Pink F (001 ANTP)	■	■	■	■	■
Crystal Astral Pink F (001 API)	■	■	■	■	■
Crystal Golden Shadow F (001 GSHA)	■	■	■	■	■

4884/S



Ring/Hole, Back Configuration	5.5x5 mm	6.6x6 mm	8.8x8 mm	11x10 mm	15.4x14 mm
00 C = No ring/hole, closed	■	■	■	■	■
H2 O = 4 holes/2 each side, open	■	■	■	■	■

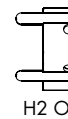
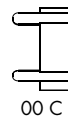

Fancy Stones & Settings

PRODUCT DETAILS

Article Size	Packing Unit = Minimum Order Quantity in Pieces	Average Net Weight in Gram per Packing Unit Crystal (001)	Average Gross Weight in Gram per Packing Unit Crystal (001)
4120			
6x4 mm	360	31.2	42.1
8x6 mm	180	44.7	45.2
14x10 mm	144	170.2	193.8
18x13 mm	48	112.3	132.9
25x18 mm	24	152.2	177.6
4120/S			
6x4 mm	360		43.3
8x6 mm	180		79.3
14x10 mm	144		86.0
18x13 mm	48		49.5
25x18 mm	24		48.8
4127			
30x22 mm	24	173.64	218.72
39x28 mm	12	226.8	246.4
4127/S			
30x22 mm	24		53.0
39x28 mm	12		64.4
4128			
6x4 mm	360	26.8	37.6
8x6 mm	360	76.5	87.3
10x8 mm	144	59.9	80.2
14x10 mm	144	105.6	129.2
4128/S			
6x4 mm	360		43.3
8x6 mm	360		79.3
10x8 mm	144		80.0
14x10 mm	144		86.0
4137			
15x11 mm	72	48.2	66.4
22x16 mm	24	44.2	64.2
33x24 mm	18	117.5	144.2
4139			
14 mm	72	53.2	82.7
20 mm	24	46.7	78.7
30 mm	18	124.6	153.0
4161			
15x5 mm	72	29.5	51.6
21x7 mm	48	71.5	96.5
27x9 mm	24	65.8	94.2
4161/S			
15x5 mm	72		24.3
21x7 mm	48		27.0
27x9 mm	24		21.5
4196			
23x20 mm	16	113.2	141.2
30x26 mm	12	192.1	215.2
4196/S			
23x20 mm	16		41.8
30x26 mm	12		49.1

Fancy Stones & Settings

Article Size	Packing Unit = Minimum Order Quantity in Pieces	Average Net Weight in Gram per Packing Unit Crystal (001)	Average Gross Weight in Gram per Packing Unit Crystal (001)
4200			
11x3 mm	360	28.6	39.4
15x4 mm	144	26.2	37.1
35x9.5 mm	16	41.9	63.8
48x13 mm	6	38.3	70.8
4200/S			
11x3 mm	360		64.9
15x4 mm	144		39.7
35x9.5 mm	16		34.1
48x13 mm	6		23.6
4224			
10x8 mm	144	51.4	63.3
14x11 mm	72	53.2	72.3
23x18 mm	36	59.8	79.4
4224/S			
10x8 mm	144		62.7
14x11 mm	72		55.5
23x18 mm	36		41.5
4227			
32x17 mm	24	100.8	123.4
4227/S			
32x17 mm	24		48.0
4228			
4x2 mm	720	9.2	18.3
5x2.5 mm	720	18.9	28.0
6x3 mm	720	30.5	39.6
8x4 mm	360	32.9	42.0
10x5 mm	360	60.7	72.1
15x7 mm	144	63.9	88.1
4228/S			
5x2.5 mm	720		46.9
6x3 mm	720		75.7
8x4 mm	360		50.5
10x5 mm	360		82.9
15x7 mm	144		85.8
4230			
14x9 mm	144	75.116	98.824
19x12 mm	72	86.486	113.884
23x15 mm	48	102.816	122.976
4230/S			
14x9 mm	144		57.6
19x12 mm	72		72.0
23x15 mm	48		72.0
4320			
6x4 mm	360	25.7	34.8
8x6 mm	180	30.7	39.8
10x7 mm	144	48.6	68.9
14x10 mm	144	126.6	150.2
18x13 mm	48	85.2	105.8
4320/S			
6x4 mm	360		43.3
8x6 mm	180		39.7
10x7 mm	144		71.4
14x10 mm	144		126.1
18x13 mm	48		54.6

Fancy Stones & Settings

Article Size	Packing Unit = Minimum Order Quantity in Pieces	Average Net Weight in Gram per Packing Unit Crystal (001)	Average Gross Weight in Gram per Packing Unit Crystal (001)
4327			
30x20 mm	24	161.8	206.8
40x27 mm	12	201.6	226.3
4327/S			
30x20 mm	24		51.5
40x27 mm	12		63.7
4328			
6x3.6 mm	720	40.0	50.5
8x4.8 mm	360	42.1	53.0
10x6 mm	144	29.2	50.5
13x7.8 mm	144	65.1	88.3
4328/S			
6x3.6 mm	720		79.4
8x4.8 mm	360		54.1
10x6 mm	144		33.9
13x7.8 mm	144		51.2
4370			
11x10 mm	144	82.8	100.9
15.5x14 mm	72	107.3	127.4
20x18 mm	48	149.5	170.0
4370/S			
11x10 mm	144		78.6
15.5x14 mm	72		75.0
20x18 mm	48		77.1
4418			
6 mm	216	55.35	79.20
8 mm	216	119.93	147.84
4418/S			
6 mm	216		54.0
8 mm	216		138.2
4428			
1.5 mm	1,440	4.32	15.1
2 mm	1,440	12.2	23.0
3 mm	1,440	34.8	57.6
4 mm	1,440	108.5	119.5
5 mm	360	51.6	61.9
6 mm	360	88.55	93.0
8 mm	144	84.5	99.6
4428/S			
4 mm	1,440		104.5
5 mm	360		58.0
6 mm	360		50.0
8 mm	144		45.5
4439			
14 mm	72	88.0	111.6
20 mm	24	80.4	123.0
30 mm	12	127.6	145.8

Fancy Stones & Settings

Article Size	Packing Unit = Minimum Order Quantity in Pieces	Average Net Weight in Gram per Packing Unit Crystal (001)	Average Gross Weight in Gram per Packing Unit Crystal (001)
4447			
6 mm	360	87.5	98.3
8 mm	144	71.5	91.9
10 mm	144	133.9	157.2
12 mm	72	117.6	137.9
4447/S			
6 mm	360		50.0
8 mm	144		47.0
10 mm	144		70.5
12 mm	72		56.0
4461			
8 mm	144	56.9	77.2
12 mm	72	84.4	103.4
16 mm	72	214.4	238.0
4461/S			
8 mm	144		62.7
12 mm	72		52.8
16 mm	72		92.0
4470			
10 mm	144	91.6	111.9
12 mm	72	74.7	92.9
18 mm	48	170.3	190.9
4470/S			
10 mm	144		54.5
12 mm	72		53.3
18 mm	48		92.0
4500			
3x2 mm	1,440	20.5	32.0
6x2 mm	720	18.4	27.5
10x3 mm	360	36.6	47.6
4500/S			
6x2 mm	720		61.3
10x3 mm	360		68.5
4501			
4x2 mm	720	16.8	25.9
5x2 mm	720	18.1	27.2
5x2.5 mm	720	20.9	30.0
7x3 mm	720	60.2	71.1
10x5 mm	360	96.2	106.9
4501/S			
5x2.5 mm	720		61.3
7x3 mm	720		58.0
10x5 mm	360		147.7
4502			
3x1 mm	720	2.2	11.4
4505			
8x5 mm	240	44.2	55.0
10x6 mm	144	52.6	73.7
14x8 mm	108	103.4	120
4505/S			
8x5 mm	240		54.1
10x6 mm	144		72.8
14x8 mm	108		91.1

Fancy Stones & Settings

Article Size	Packing Unit = Minimum Order Quantity in Pieces	Average Net Weight in Gram per Packing Unit Crystal (001)	Average Gross Weight in Gram per Packing Unit Crystal (001)
4524			
12x6 mm	144	67.7	89.4
16x8 mm	72	78.0	102.7
23x11 mm	36	104.0	131.9
4524/S			
12x6 mm	144		77.1
16x8 mm	72		64.9
23x11 mm	36		60.6
4527			
8x6 mm	144	53.7	64.57
14x10 mm	72	122.4	144.9
18x13 mm	72	246.9	270.6
4527/S			
8x6 mm	144		45.5
14x10 mm	72		60.3
18x13 mm	72		104.5
4547			
15x5 mm	72	37.4	58.9
21x7 mm	48	65.3	98.7
24x8 mm	48	97.4	130.5
30x10 mm	24	101.0	124.4
4547/S			
15x5 mm	72		36.8
21x7 mm	48		43.5
24x8 mm	48		50.5
30x10 mm	24		39.0
4565			
14x10 mm	72	71.5	88.9
18x13 mm	48	101.2	121.8
4565/S			
14x10 mm	72		64.2
18x13 mm	48		69.9
4568			
8x6 mm	144	34.70	55.79
14x10 mm	72	74.87	103.12
18x13 mm	24	46.17	64.73
27x18 mm	20	105.84	132.70
4568/S			
8x6 mm	144		36.7
14x10 mm	72		54.0
18x13 mm	24		37.2
27x18 mm	20		61.0
4600			
6x4 mm	360	40.9	51.8
8x6 mm	144	41.2	52.2
10x8 mm	144	84.0	104.0
12x10 mm	144	146.7	170.3
4600/S			
6x4 mm	360		46.9
8x6 mm	144		39.7
10x8 mm	144		90.1
12x10 mm	144		127.5

Fancy Stones & Settings

Article Size	Packing Unit = Minimum Order Quantity in Pieces	Average Net Weight in Gram per Packing Unit Crystal (001)	Average Gross Weight in Gram per Packing Unit Crystal (001)
4610			
14x10 mm	144	171.3	194.9
18x13 mm	48	124.9	145.5
20x15 mm	24	88.5	105.8
4610/S			
14x10 mm	144		104.5
18x13 mm	48		66.0
20x15 mm	24		51.0
4627			
27x18.5 mm	24	125.3	170.8
37x25.5 mm	12	170.7	197.8
4627/S			
27x18.5 mm	24		54.0
37x25.5 mm	12		60.1
4675			
23 mm	24	175.4	220.5
4675/S			
23 mm	24		73.8
4678			
8 mm	144	42.407	51.555
14 mm	48	81.325	102.655
23 mm	16	98.784	121.309
4678/G			
8 mm	144	42.407	51.555
14 mm	48	81.325	102.655
23 mm	16	98.784	121.309
4678/S			
8 mm	144		37.4
14 mm	48		38.4
23 mm	16		49.6
4706			
7 mm	144	23.714	44.378
12 mm	72	61.508	83.886
17 mm	48	96.365	119.791
24 mm	16	109.066	145.716
4706/S			
7 mm	144		28.8
12 mm	72		36.0
17 mm	48		81.6
24 mm	16		48.0
4717			
15.5 mm	72	139.9	148.3
21.5 mm	32	152.8	161.8
4717/S			
15.5 mm	72		86.0
21.5 mm	32		54.0
4722			
4 mm	480	12.0	21.1
6 mm	180	16.4	25.5
8 mm	144	29.0	48.1
10 mm	144	61.4	84.4
4722/S			
4 mm	480		46.9
6 mm	180		30.7
8 mm	144		45.1
10 mm	144		74.3

Fancy Stones & Settings

Article Size	Packing Unit = Minimum Order Quantity in Pieces	Average Net Weight in Gram per Packing Unit Crystal (001)	Average Gross Weight in Gram per Packing Unit Crystal (001)
4727			
23 mm	24	131.8	176.8
4727/S			
23 mm	24		41.0
4739			
14x11 mm	144	143.7	170.4
20x16 mm	72	200.7	229.8
4739/S			
14x11 mm	144		117.5
20x16 mm	72		112.3
4744			
6 mm	720	62.3	72.8
10 mm	288	126.0	158.1
4744/S			
6 mm	720		104.5
10 mm	288		93.0
4745			
5 mm	720	35.6	46.4
10 mm	144	48.5	71.3
4745/S			
5 mm	720		68.5
10 mm	144		43.0
4747			
5 mm	720	40.0	49.7
4747/S			
5 mm	720		68.5
4748			
5 mm	720	72.0	80.6
10 mm	288	195.8	241.9
4748/S			
5 mm	720		90.1
10 mm	288		162.1
4756			
19x11.5 mm	96	112.5	171.3
27x16 mm	40	152.0	194.0
39x23.5 mm	24	264.0	229.2
4756/S			
19x11.5 mm	96		84.3
27x16 mm	40		66.1
39x23.5 mm	24		72.3
4757			
14x8.5 mm	96	82.6	104.8
19x11.5 mm	96	182.4	211.6
4757/S			
14x8.5 mm	96		65.2
19x11.5 mm	96		125.6
4760			
14x8 mm	144	132.6	145.8
18x10.5 mm	96	168.7	204.7
22x12.5 mm	36	126.6	154.2
4760/S			
14x8 mm	144		105.1
18x10.5 mm	96		107.0
22x12.5 mm	36		59.4

Fancy Stones & Settings

Article Size	Packing Unit = Minimum Order Quantity in Pieces	Average Net Weight in Gram per Packing Unit Crystal (001)	Average Gross Weight in Gram per Packing Unit Crystal (001)
4773			
14x7.5 mm	72	43.122	64.774
18x9.5 mm	48	56.448	78.503
28x15 mm	20	90.720	111.115
4773/S			
14x7.5 mm	72		28.8
18x9.5 mm	48		48.0
28x15 mm	20		41.2
4789			
14 mm	72	100.8	129.2
23 mm	32	188.8	225.6
29 mm	18	214.2	242.9
4789/S			
14 mm	72		60.6
23 mm	32		70.9
29 mm	18		62.0
4790			
18x7.5 mm	108	72.3	97.1
23x10 mm	36	48.2	71.9
32x13.5 mm	30	105.5	139.5
4790/S			
18x7.5 mm	108		85.9
23x10 mm	36		47.7
32x13.5 mm	30		75.5
4795			
14 mm	72	72.0	106.92
19 mm	48	124.8	152.5
28 mm	24	204.0	254.8
4795/S			
14 mm	72		63.5
19 mm	48		80.5
28 mm	24		78.1
4809			
13x12 mm	72	47.779	68.463
17x15.5 mm	48	63.302	84.793
27x25 mm	16	86.312	100.020
4809/S			
13x12 mm	72		36.0
17x15.5 mm	48		48.0
27x25 mm	16		28.8
4810			
13x12 mm	72	48.384	69.068
4810/S			
13x12 mm	72		36.0
4827			
28 mm	24	214.9	253.3
4827/S			
28 mm	24		55.5

Fancy Stones & Settings

Article Size	Packing Unit = Minimum Order Quantity in Pieces	Average Net Weight in Gram per Packing Unit Crystal (001)	Average Gross Weight in Gram per Packing Unit Crystal (001)
4831			
5.5x5 mm	360	26.5	37.3
8.8x8 mm	144	40.0	60.4
11x10 mm	144	80.1	101.5
4831/S			
5.5x5 mm	360		54.1
8.8x8 mm	144		46.9
11x10 mm	144		97.3
4835			
3.5 mm	1,440	48.2	54.0
4841			
4 mm	288	45.3	66.6
6 mm	144	77.2	95.3
8 mm	72	89.2	107.4
4869			
4 mm	480	36.2	45.3
6 mm	180	47.2	56.4
8 mm	144	90.8	109.0
10 mm	72	88.3	105.3
4884			
5.5x5 mm	360	39.0	49.7
6.6x6 mm	360	67.2	78.0
8.8x8 mm	288	111.4	138.1
11x10 mm	144	107.3	127.4
15.4x14 mm	72	128.7	149.3
4884/S			
5.5x5 mm	360		54.1
6.6x6 mm	360		72.1
8.8x8 mm	288		46.9
11x10 mm	144		101.6
15.4x14 mm	72		103.1











Beads

Beads offer the highest standard available on the market. The high-quality precision cutting and the clear through-hole achieve high brilliance and clarity. Rounded hole edges reduce the wear on thread and increase the durability of designs. The assortment is divided into classic, romantic, and progressive shape characteristics. They are available in the latest fashion colors, effects, and cuts. A wide range of colors and effects opens up endless possibilities for different combinations and designs. The main application techniques are beading, wiring, stringing, and weaving. Crystal Mesh Balls are also part of this product group.

COLORS & EFFECTS

Colors

	Provence Lavender 283		Light Sapphire 211
	Crystal 001		Light Azure 361
	White Alabaster 281		Aquamarine 202
	White Opal 234		Air Blue Opal 285
	Light Silk 261		Sapphire 206
	Silk 391		Capri Blue 243
	Light Peach 362		Dark Indigo 288
	Rosaline 508		Montana 207
	Rose Water Opal 395		Turquoise 267
	Vintage Rose 319		Caribbean Blue Opal 394
	Light Rose 223		Light Turquoise 263
	Rose Peach 262		Blue Zircon 229
	Padparadscha 542		Indicolite 379
	Indian Pink 289		Indian Sapphire 217
	Sun 248		Denim Blue 266
	Fireopal 237		Black Diamond 215
	Hyacinth 236		Pacific Opal 390
	Light Siam 227		Chrysolite Opal 294
	Rose 209		Chrysolite 238
	Fuchsia 502		Peridot 214
	Ruby 501		Erinite 360
	Siam 208		Fern Green 291
	Burgundy 515		Dark Moss Green 260
	Garnet 241		Emerald 205
	Amethyst 204		Palace Green Opal 393
	Cyclamen Opal 398		Olivine 228
	Purple Velvet 277		Khaki 550
	Tanzanite 539		Greige 284
	Violet 371		Light Grey Opal 383
	Light Amethyst 212		

	Sand Opal 287
	Light Colorado Topaz 246
	Jonquil 213
	Citrine 249
	Light Topaz 226
	Sunflower 292
	Topaz 203
	Tangerine 259
	Light Smoked Topaz 221
	Smoked Topaz 220
	Smoky Quartz 225
	Mocca 286
	Jet 280

	Crystal Rose Gold 001 ROGL
	Crystal Rose Gold 2x 001 ROGL2
	Crystal Copper** 001 COP
	Crystal Astral Pink 001 API
	Crystal Red Magma** 001 REDM
	Crystal Antique Pink 001 ANTP
	Crystal Vitrail Light** 001 VL
	Crystal Vitrail Medium** 001 VM
	Crystal Lilac Shadow 001 LISH
	Crystal Heliotrope** 001 HEL
	Crystal Bermuda Blue** 001 BBL
	Crystal Metallic Blue 2x** 001 METBL2
	Crystal Blue Shade** 001 BLSH
	Crystal Tabac 001 TAB

	Rose AB FC 209 AB FC
	Violet AB FC 371 AB FC
	Light Amethyst AB FC 212 AB FC
	Light Siam AB FC 227 AB FC
	Crystal Astral Pink FC 001 API FC
	Padparadscha AB FC 542 AB FC
	Emerald AB FC 205 AB FC
	Montana AB FC 207 AB FC
	Indian Sapphire AB FC 217 AB FC
	Indicolite AB FC 379 AB FC
	Capri Blue AB FC 243 AB FC
	Aquamarine AB FC 202 AB FC
	Tanzanite AB FC 539 AB FC
	Sapphire AB FC 206 AB FC

Crystal Blend Colors

	Amethyst Blend 721
	Provence Lavender- Chrysolite Blend 726
	Crystal-Montana Blend 725
	Burgundy-Blue Zircon Blend 723
	Fern Green-Topaz Blend 724
	Topaz Blend 722

	Crystal Iridescent Green 001 IRIG
	Crystal Dorado 2x** 001 DOR2
	Crystal Metallic Light Gold 2x** 001 MLGLD2
	Crystal Bronze Shade** 001 BRSH
	Crystal Satin** 001 SAT
	Crystal Comet Argent Light** 001 CAL
	Crystal Silver Night** 001 SINI
	Jet Nut 2x** 280 NUT2
	Jet Hematite** 280 HEM
	Jet Hematite 2x** 280 HEM2





	Turquoise AB FC 267 AB FC
	Fuchsia AB FC 502 AB FC
	Peridot AB FC 214 AB FC
	Chrysolite AB FC 238 AB FC
	Jonquil AB FC 213 AB FC
	Light Colorado Topaz AB FC 246 AB FC
	Topaz AB FC 203 AB FC
	Jet AB FC 280 AB FC
	Black Diamond AB FC 215 AB FC
	Siam AB FC 208 AB FC
	Amethyst AB FC 204 AB FC

Effects

	Crystal Silver Shade 001 SSHA
	Crystal Moonlight 001 MOL
	Crystal Aurore Boreale 001 AB
	Crystal Aurore Boreale 2x 001 AB2
	Crystal Aurore Boreale Satin 001 ABSAT
	Crystal Luminous Green** 001 LUMG
	Crystal Golden Shadow** 001 GSHA

Full Coating

	Crystal Comet Argent Light FC** 001 CAL FC
	Crystal Aurore Boreale FC 001 AB FC
	White Opal AB FC 234 AB FC
	Light Rose AB FC 223 AB FC

	Crystal Iridescent Green FC 001 IRIG FC
	Crystal Bronze Shade FC** 001 BRSH FC
	Crystal Metallic Blue FC* 001 METBL FC
	Jet Hematite FC 280 HEM FC

Numerical Order

001	Crystal	202	Aquamarine	234	White Opal	292	Sunflower
001 AB	Crystal Aurore Boreale	202 AB FC	Aquamarine AB FC	234 AB FC	White Opal AB FC	294	Chrysolite Opal
001 AB2	Crystal Aurore Boreale 2x	203	Topaz	236	Hyacinth	319	Vintage Rose
001 ABSAT	Crystal Aurore Boreale Satin	203 AB FC	Topaz AB FC	237	Fireopal	360	Erinite
001 AB FC	Crystal Aurore Boreale FC	204	Amethyst	238	Chrysolite	361	Light Azure
001 ANTP	Crystal Antique Pink	204 AB FC	Amethyst AB FC	238 AB FC	Chrysolite AB FC	362	Light Peach
001 API	Crystal Astral Pink	205 AB FC	Emerald AB FC	241	Garnet	371	Violet
001 API FC	Crystal Astral Pink FC	205	Emerald	243	Capri Blue	371 AB FC	Violet AB FC
001 BBL	Crystal Bermuda Blue	206	Sapphire	243 AB FC	Capri Blue AB FC	379	Indicolite
001 BLSH	Crystal Blue Shade**	206 AB FC	Sapphire AB FC	246	Light Colorado Topaz	379 AB FC	Indicolite AB FC
001 BRSH	Crystal Bronze Shade**	207	Montana	246 AB FC	Light Colorado Topaz AB FC	383	Light Grey Opal
001 BRSH FC	Crystal Bronze Shade FC**	207 AB FC	Montana AB FC	248	Sun	390	Pacific Opal
001 CAL	Crystal Comet Argent Light**	208	Siam	249	Citrine	391	Silk
001 CAL FC	Crystal Comet Argent Light FC**	208 AB FC	Siam AB FC	259	Tangerine	393	Palace Green Opal
001 COP	Crystal Copper**	209	Rose	260	Dark Moss Green	394	Caribbean Blue Opal
001 DOR2	Crystal Dorado 2x**	209 AB FC	Rose AB FC	261	Light Silk	395	Rose Water Opal
001 GSHA	Crystal Golden Shadow**	211	Light Sapphire	262	Rose Peach	398	Cyclamen Opal
001 HEL	Crystal Heliotrope**	212	Light Amethyst	263	Light Turquoise	501	Ruby
001 IRIG	Crystal Iridescent Green	212 AB FC	Light Amethyst AB FC	266	Denim Blue	502	Fuchsia
001 IRIG FC	Crystal Iridescent Green FC	213	Jonquil	267	Turquoise	502 AB FC	Fuchsia AB FC
001 IISH	Crystal Lilac Shadow	213 AB FC	Jonquil AB FC	267 AB FC	Turquoise AB FC	508	Rosaline
001 LUMG	Crystal Luminous Green**	214	Peridot	277	Purple Velvet	515	Burgundy
001 METBL2	Crystal Metallic Blue 2x**	214 AB FC	Peridot AB FC	280	Jet	539	Tanzanite
001 METBL2 FC	Crystal Metallic Blue FC*	215 AB FC	Black Diamond AB FC	280 AB FC	Jet AB FC	539 AB FC	Tanzanite AB FC
001 MLGLD2	Crystal Metallic Light Gold 2x**	215	Black Diamond	280 HEM	Jet Hematite**	542	Padparadscha
001 MOL	Crystal Moonlight	217	Indian Sapphire	280 HEM2	Jet Hematite 2x**	542 AB FC	Padparadscha AB FC
001 REDM	Crystal Red Magma**	217 AB FC	Indian Sapphire AB FC	280 HEM FC	Jet Hematite FC	550	Khaki
001 ROGL	Crystal Rose Gold	220	Smoked Topaz	280 NUT2	Jet Nut 2x**	721	Amethyst Blend
001 ROGL2	Crystal Rose Gold 2x	221	Light Smoked Topaz	281	White Alabaster	722	Topaz Blend
001 SAT	Crystal Satin**	223	Light Rose	283	Provence Lavender	723	Burgundy-Blue
001 SINI	Crystal Silver Night**	223 AB FC	Light Rose AB FC	284	Greige	724	Zircon Blend
001 SSHA	Crystal Silver Shade**	225	Smoky Quartz	285	Air Blue Opal	725	Fern Green
001 TAB	Crystal Tabac**	226	Light Topaz	286	Mocca	726	Topaz Blend
001 VL	Crystal Vitrail Light**	227	Light Siam	287	Sand Opal		Crystal-Montana Blend
001 VM	Crystal Vitrail Medium	227 AB FC	Light Siam AB FC	288	Dark Indigo		Provence Lavender
		228	Olivine	289	Indian Pink		Chrysolite Blend
		229	Blue Zircon	291	Fern Green		

Alphabetical Order

Air Blue Opal (285)	Crystal Iridescent Green (001 IRIG)	Indicolite (379)	Peridot AB FC (214 AB FC)
Amethyst (204)	Crystal Iridescent Green FC (001 IRIG FC)	Indicolite AB FC (379 AB FC)	Provence Lavender (283)
Amethyst AB FC (204 AB FC)	Crystal Lilac Shadow (001 IISH)	Jet (280)	Provence Lavender-Chrysolite Blend (726)
Amethyst Blend (721)	Crystal Luminous Green** (001 LUMG)	Jet AB FC (280 AB FC)	Purple Velvet (277)
Aquamarine (202)	Crystal Metallic Blue 2x** (001 METBL2)	Jet Hematite** (280 HEM)	Rosaline (508)
Aquamarine AB FC (202 AB FC)	Crystal Metallic Blue FC* (001 METBL2 FC)	Jet Hematite 2x** (280 HEM2)	Rose (209)
Black Diamond (215)	Crystal Metallic Light Gold 2x** (001 MLGLD2)	Jet Hematite FC (280 HEM FC)	Rose AB FC (209 AB FC)
Black Diamond AB FC (215 AB FC)	Crystal-Montana Blend (725)	Jet Nut 2x** (280 NUT2)	Rose Peach (262)
Blue Zircon (229)	Crystal Moonlight (001 MOL)	Jonquil (213)	Rose Water Opal (395)
Burgundy (515)	Crystal Red Magma** (001 REDM)	Jonquil AB FC (213 AB FC)	Ruby (501)
Burgundy-Blue Zircon Blend (723)	Crystal Rose Gold (001 ROGL)	Khaki (550)	Sand Opal (287)
Capri Blue (243)	Crystal Rose Gold 2x (001 ROGL2)	Light Amethyst (212)	Sapphire (206)
Capri Blue AB FC (243 AB FC)	Crystal Satin** (001 SAT)	Light Amethyst AB FC (212 AB FC)	Sapphire AB FC (206 AB FC)
Caribbean Blue Opal (394)	Crystal Silver Night** (001 SINI)	Light Azure (361)	Siam (208)
Chrysolite (238)	Crystal Silver Shade (001 SSHA)	Light Colorado Topaz (246)	Siam AB FC (208 AB FC)
Chrysolite AB FC (238 AB FC)	Crystal Silver Shade** (001 SSHA)	Light Colorado Topaz AB FC (246 AB FC)	Silk (391)
Chrysolite Opal (294)	Crystal Tabac** (001 TAB)	Light Colorado Topaz AB FC (246 AB FC)	Smoked Topaz (220)
Citrine (249)	Crystal Vitrail Light** (001 VL)	Light Grey Opal (383)	Smoky Quartz (225)
Crystal (001)	Crystal Vitrail Medium** (001 VM)	Light Peach (362)	Sun (248)
Crystal Antique Pink (001 ANTP)	Cyclamen Opal (398)	Light Rose (223)	Sunflower (292)
Crystal Astral Pink (001 API)	Dark Indigo (288)	Light Rose AB FC (223 AB FC)	Tangerine (259)
Crystal Astral Pink FC (001 API FC)	Dark Moss Green (260)	Light Sapphire (211)	Tanzanite (539)
Crystal Aurore Boreale (001 AB)	Denim Blue (266)	Light Siam (227)	Tanzanite AB FC (539 AB FC)
Crystal Aurore Boreale 2x (001 AB2)	Emerald (205)	Light Siam AB FC (227 AB FC)	Topaz (203)
Crystal Aurore Boreale FC (001 AB FC)	Emerald AB FC (205 AB FC)	Light Silk (261)	Topaz AB FC (203 AB FC)
Crystal Aurore Boreale Satin (001 ABSAT)	Erinite (360)	Light Smoked Topaz (221)	Topaz Blend (722)
Crystal Bermuda Blue (001 BBL)	Fern Green (291)	Light Topaz (226)	Turquoise (267)
Crystal Blue Shade** (001 BLSH)	Fern Green-Topaz Blend (724)	Light Turquoise (263)	Turquoise AB FC (267 AB FC)
Crystal Bronze Shade** (001 BRSH)	Fireopal (237)	Mocca (286)	Vintage Rose (319)
Crystal Bronze Shade FC** (001 BRSH FC)	Fuchsia (502)	Montana (207)	Violet (371)
Crystal Comet Argent Light** (001 CAL)	Fuchsia AB FC (502 AB FC)	Montana AB FC (207 AB FC)	Violet AB FC (371 AB FC)
Crystal Comet Argent Light FC** (001 CAL FC)	Garnet (241)	Olivine (228)	White Alabaster (281)
Crystal Copper** (001 COP)	Greige (284)	Pacific Opal (390)	White Opal (234)
Crystal Dorado 2x** (001 DOR2)	Hyacinth (236)	Padparadscha (542)	White Opal AB FC (234 AB FC)
Crystal Golden Shadow** (001 GSHA)	Indian Pink (289)	Padparadscha AB FC (542 AB FC)	
Crystal Heliotrope** (001 HEL)	Indian Sapphire (217)	Palace Green Opal (393)	
	Indian Sapphire AB FC (217 AB FC)	Peridot (214)	

This color chart is valid for the product groups Beads, BeCharmed & Pavé and Pendants.

The displayed assortment is not entirely available for all products within the product groups. For details on available colors and effects, please see the product matrix for the respective item.

Classic Colors: This color range offers a wide choice of traditional Swarovski crystal colors.

Exclusive Colors: This color range is offered exclusively by Swarovski.

The standard assortment of colors and effects may vary according to the product group.







































Slight changes in shades are unavoidable. Colors may vary according to cut and shape.

The plating resistance of effects is tested according to Swarovski's plating guidelines (WWW.SWAROVSKI.COM/PROFESSIONAL). Customers are advised to carry out their own tests if customers' plating parameters diverge from Swarovski plating guidelines.

* Colors are only available as special productions.

** Crystals are not resistant to plating and similar processing.

SUMMARY

1 2 3  5000 2, 3, 4, 5, 6, 7, 8, 10, 12, 14, 16, 18, 20 mm	1 2 3  5055 8x6, 10x8 mm	1 2 3  5540 12, 17 mm
 5003 6, 8, 10, 12, 14 mm	 5056 10x6, 12x8 mm	 5541 11, 15 mm
 5005 8, 12, 16 mm	 5139 12.5 mm	 5542 8, 11 mm
 5020 6, 8, 10 mm	 5181 13x7, 17x9 mm	 5601 4, 6, 8, 10, 12 mm
 5026 6, 8, 10 mm	 5200 6x4, 7.5x5 mm	 5603 8, 10 mm
 5028/4 6, 8, 10 mm	 5203 12x8 mm	 5621 14, 18 mm
 5040 4, 6, 8, 12, 18 mm	 5305 5, 6 mm	 5624 10, 14 mm
 5041 18 mm	 5308 6 mm	 5625 10 mm
 5050 14x10, 22x16 mm	 5328 2.5, 3, 4, 5, 6, 8, 10 mm	 5650 12x8, 16x10 mm
 5051 8x6, 10x8 mm	 5500 9x6, 10.5x7, 12x8 mm	 5714 8, 12 mm
 5052 6, 8 mm	 5520 12 mm	 5727 14 mm
 5053 6, 8 mm	 5523 12, 16 mm	 5742 8, 10 mm
 5054 6, 8 mm	 5535 19x5, 23.5x5 mm	 5743 12, 17 mm

SUMMARY

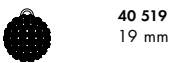
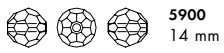
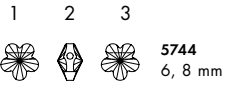

Beads

5000



Size	2 mm	3 mm	4 mm	5 mm	6 mm	7 mm	8 mm	10 mm	12 mm	14 mm	16 mm	18 mm	20 mm
------	------	------	------	------	------	------	------	-------	-------	-------	-------	-------	-------

Crystal

Crystal (001)

Colors

Plain Colors

- Amethyst (204)
- Aquamarine (202)
- Black Diamond (215)
- Blue Zircon (229)
- Capri Blue (243)
- Chrysolite (238)
- Dark Indigo (288)
- Dark Moss Green (260)
- Denim Blue (266)
- Emerald (205)
- Erinite (360)
- Fern Green (291)
- Fireopal (237)
- Fuchsia (502)
- Greige (284)
- Indian Pink (289)
- Indian Sapphire (217)
- Indicolite (379)
- Jet (280)
- Jonquil (213)
- Light Amethyst (212)
- Light Azore (361)
- Light Colorado Topaz (246)
- Light Rose (223)
- Light Sapphire (211)
- Light Siam (227)
- Light Silk (261)
- Light Smoked Topaz (221)
- Light Topaz (226)
- Light Turquoise (263)
- Montana (207)
- Olivine (228)
- Padparadscha (542)
- Peridot (214)
- Purple Velvet (277)
- Rose (209)
- Rose Peach (262)
- Sapphire (206)
- Siam (208)

Crystal (001)	■	■	■	■	■	■	■	■	■	■	■	■	■
Amethyst (204)		■	■		■		■	■					
Aquamarine (202)		■	■		■		■	■					
Black Diamond (215)		■	■		■		■	■					
Blue Zircon (229)			■		■		■						
Capri Blue (243)			■		■		■						
Chrysolite (238)			■		■		■						
Dark Indigo (288)			■		■		■	■					
Dark Moss Green (260)		■	■		■		■	■					
Denim Blue (266)			■		■		■	■					
Emerald (205)		■	■		■		■						
Erinite (360)			■		■		■						
Fern Green (291)			■		■		■						
Fireopal (237)			■		■		■						
Fuchsia (502)	■	■	■		■		■	■					
Greige (284)			■		■		■						
Indian Pink (289)			■		■		■						
Indian Sapphire (217)			■		■		■						
Indicolite (379)			■		■		■						
Jet (280)	■	■	■	■	■		■	■	■	■			
Jonquil (213)			■		■		■						
Light Amethyst (212)			■		■		■						
Light Azore (361)			■		■		■						
Light Colorado Topaz (246)		■	■		■		■						
Light Rose (223)		■	■		■		■						
Light Sapphire (211)			■		■		■						
Light Siam (227)		■	■		■		■	■					
Light Silk (261)			■		■		■						
Light Smoked Topaz (221)			■		■		■						
Light Topaz (226)			■		■		■	■					
Light Turquoise (263)		■	■		■		■	■					
Montana (207)			■		■		■	■					
Olivine (228)			■		■		■						
Padparadscha (542)			■		■		■						
Peridot (214)			■		■		■						
Purple Velvet (277)			■		■		■						
Rose (209)			■		■		■						
Rose Peach (262)			■		■		■						
Sapphire (206)			■		■		■						
Siam (208)		■	■		■		■	■					

Beads

04 Beads

	5000													
	Size	2 mm	3 mm	4 mm	5 mm	6 mm	7 mm	8 mm	10 mm	12 mm	14 mm	16 mm	18 mm	20 mm
Silk (391)				■		■		■						
Smoked Topaz (220)				■		■		■						
Tangerine (259)		■	■	■	■	■		■						
Tanzanite (539)				■		■		■						
Topaz (203)				■		■		■						
Turquoise (267)				■		■		■						
Vintage Rose (319)				■		■		■						
Violet (371)				■		■		■						
White Alabaster (281)				■		■		■						
Opal Colors														
Cyclamen Opal (398)				■		■		■						
Pacific Opal (390)				■		■		■						
Palace Green Opal (393)				■		■		■						
White Opal (234)		■	■			■		■						
Crystal Blend Colors														
Burgundy-Blue Zircon Blend (723)						■		■						
Crystal-Montana Blend (725)						■		■	■					
Fern Green-Topaz Blend (724)						■		■						
Provence Lavender-Chrysolite Blend (726)						■		■	■					
Crystal Effects														
Transparent Effects														
Crystal AB (001 AB)	■	■	■	■	■	■	■	■	■	■	■	■	■	■
Crystal Antique Pink (001 ANTP)				■		■		■						
Crystal Blue Shade (001 BLSH)		■	■			■		■	■					
Crystal Bronze Shade (001 BRSH)		■	■			■		■	■					
Crystal Copper (001 COP)				■		■		■						
Crystal Golden Shadow (001 GSHA)	■	■	■			■		■	■	■				
Crystal Lilac Shadow (001 LISH)		■	■			■		■	■					
Crystal Luminous Green (001 LUMG)		■	■			■		■						
Crystal Moonlight (001 MOL)	■		■			■		■	■					
Crystal Satin (001 SAT)				■		■		■						
Crystal Silver Night (001 SINI)		■	■			■		■						
Crystal Silver Shade (001 SSHA)	■	■	■			■		■						
Crystal Vitrail Medium (001 VM)				■		■		■						
Metallic Effects														
Crystal Dorado (001 DOR)				■		■		■						
Crystal Iridescent Green (001 IRIG)		■	■			■		■	■					
Crystal Metallic Light Gold 2x (001 MLG2)	■		■			■		■						
Crystal Rose Gold (001 ROGL)		■	■			■		■						
Full Coating														
Crystal AB FC (001 AB FC)				■		■		■						
Crystal Astral Pink FC (001 API FC)				■		■		■						

Beads

5000	Size												
	2 mm	3 mm	4 mm	5 mm	6 mm	7 mm	8 mm	10 mm	12 mm	14 mm	16 mm	18 mm	20 mm
Crystal Bronze Shade FC (001 BRSH FC)			■		■		■						
Crystal Comet Argent Light FC (001 CAL FC)			■		■		■						
Crystal Iridescent Green FC (001 IRIG FC)			■		■		■						
Crystal Metallic Blue FC (001 METBL FC)			■		■		■						
Color Effects													
Transparent Effects													
Amethyst AB (204 AB)			■		■		■						
Aquamarine AB (202 AB)			■		■		■						
Jet AB (280 AB)			■		■		■						
Light Rose AB (223 AB)			■		■		■						
Light Siam AB (227 AB)			■		■		■						
Rose AB (209 AB)			■		■		■						
Metallic Effects													
Jet Hematite (280 HEM)		■	■		■		■						
Jet Hematite 2x (280 HEM2)		■	■		■		■						
Full Coating													
Amethyst AB FC (204 AB FC)			■		■		■						
Aquamarine AB FC (202 AB FC)			■		■		■						
Black Diamond AB FC (215 AB FC)			■		■		■						
Capri Blue AB FC (243 AB FC)			■		■		■						
Chrysolite AB FC (238 AB FC)			■		■		■						
Emerald AB FC (205 AB FC)			■		■		■						
Fuchsia AB FC (502 AB FC)			■		■		■						
Indian Sapphire AB FC (217 AB FC)			■		■		■						
Indicolite AB FC (379 AB FC)			■		■		■						
Jet AB FC (280 AB FC)			■		■		■						
Jet Hematite FC (280 HEM FC)			■		■		■						
Jonquil AB FC (213 AB FC)			■		■		■						
Light Amethyst AB FC (212 FC)			■		■		■						
Light Colorado Topaz AB FC (246 AB FC)			■		■		■						
Light Rose AB FC (223 AB FC)			■		■		■						
Light Siam AB FC (227 AB FC)			■		■		■						
Montana AB FC (207 AB FC)			■		■		■						
Padparadscha AB FC (542 AB FC)			■		■		■						
Peridot AB FC (214 AB FC)			■		■		■						
Rose AB FC (209 AB FC)			■		■		■						
Sapphire AB FC (206 AB FC)			■		■		■						
Siam AB FC (208 AB FC)			■		■		■						
Tanzanite AB FC (539 AB FC)			■		■		■						
Topaz AB FC (203 AB FC)			■		■		■						
Turquoise AB FC (267 AB FC)			■		■		■						
Violet AB FC (371 AB FC)			■		■		■						
White Opal AB FC (234 AB FC)			■		■		■						

Beads

5003

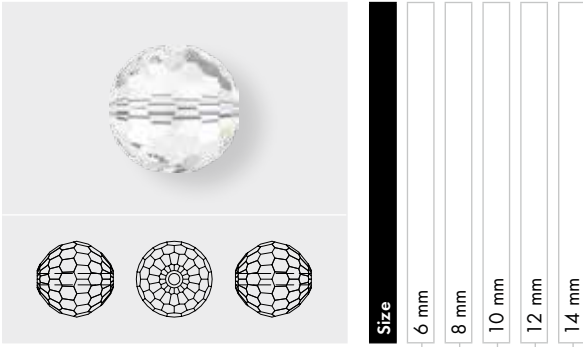

Crystal	
Crystal (001)	6 mm 8 mm 10 mm 12 mm 14 mm
Crystal Effects	
Transparent Effects	
Crystal AB (001 AB)	6 mm 8 mm 10 mm 12 mm 14 mm

5005 Chessboard Bead

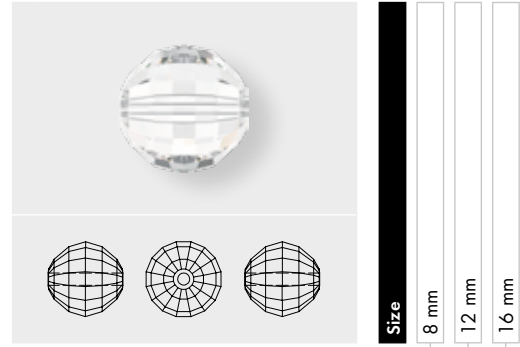

Crystal	
Crystal (001)	8 mm 12 mm 16 mm
Crystal Effects	
Transparent Effects	
Crystal AB (001 AB)	8 mm 12 mm 16 mm
Crystal Golden Shadow (001 GSHA)	8 mm 12 mm 16 mm

5020 Helix Bead

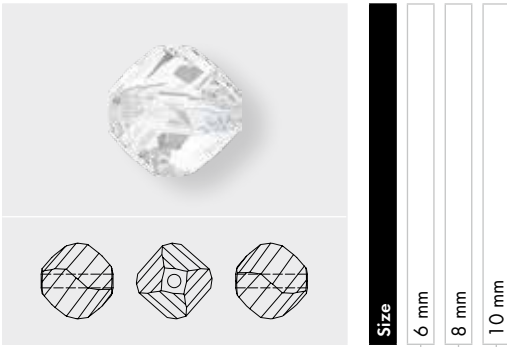

Crystal	
Crystal (001)	6 mm 8 mm 10 mm
Crystal Effects	
Transparent Effects	
Crystal AB (001 AB)	6 mm 8 mm 10 mm
Crystal Golden Shadow (001 GSHA)	6 mm 8 mm 10 mm

Beads

5026 Cabochette Bead

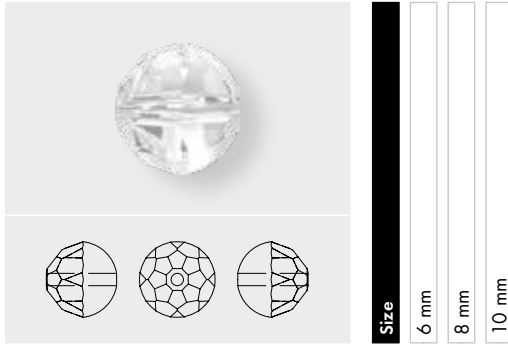

	6 mm	8 mm	10 mm
Crystal			
Crystal (001)	■	■	■
Colors			
Plain Colors			
Amethyst (204)	■	■	■
Black Diamond (215)	■	■	■
Dark Moss Green (260)	■	■	■
Fern Green (291)	■	■	■
Jet (280)	■	■	■
Light Silk (261)	■	■	■
Light Topaz (226)	■	■	■
Light Turquoise (263)	■	■	■
Siam (208)	■	■	■
Crystal Effects			
Transparent Effects			
Crystal Blue Shade (001 BLSH)	■	■	■
Crystal Bronze Shade (001 BRSH)	■	■	■
Crystal Golden Shadow (001 GSHA)	■	■	■
Crystal Lilac Shadow (001 LISH)	■	■	■
Crystal Luminous Green (001 LUMG)	■	■	■
Crystal Satin (001 SAT)	■	■	■
Crystal Silver Shade (001 SSHA)	■	■	■

5028/4 Crystal Globe Bead

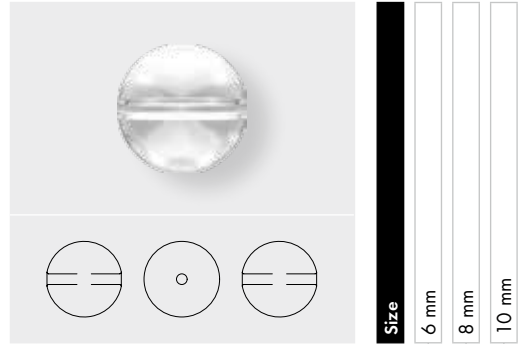

	6 mm	8 mm	10 mm
Crystal			
Crystal (001)	■	■	■
Colors			
Plain Colors			
Amethyst (204)	■	■	■
Aquamarine (202)	■	■	■
Black Diamond (215)	■	■	■
Emerald (205)	■	■	■
Fern Green (291)	■	■	■
Jet (280)	■	■	■
Light Siam (227)	■	■	■
Light Silk (261)	■	■	■
Light Topaz (226)	■	■	■
Peridot (214)	■	■	■
Siam (208)	■	■	■
Crystal Effects			
Transparent Effects			
Crystal AB (001 AB)	■	■	■
Crystal Antique Pink (001 ANTP)	■	■	■
Crystal Blue Shade (001 BLSH)	■	■	■
Crystal Golden Shadow (001 GSHA)	■	■	■
Crystal Lilac Shadow (001 LISH)	■	■	■
Crystal Luminous Green (001 LUMG)	■	■	■
Metallic Effects			
Crystal Iridescent Green (001 IRIG)	■	■	■

Beads

5040 Briolette Bead

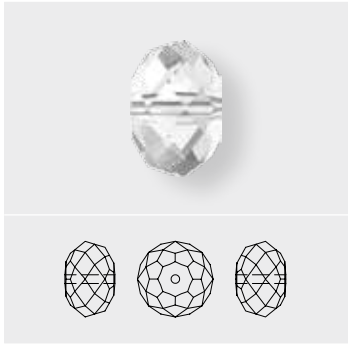

Size	4 mm	6 mm	8 mm	12 mm	18 mm
------	------	------	------	-------	-------

Crystal

Crystal (001)	■	■	■	■	■
---------------	---	---	---	---	---

Colors

Plain Colors

Amethyst (204)	■	■	■		
Aquamarine (202)		■	■	■	
Black Diamond (215)		■	■	■	
Dark Indigo (288)		■	■		
Dark Moss Green (260)	■	■	■		
Denim Blue (266)		■	■	■	
Erinite (360)		■	■	■	
Greige (284)		■	■	■	
Indicolite (379)		■	■		
Jet (280)	■	■	■	■	
Jonquil (213)		■	■		
Light Rose (223)	■	■	■		
Light Siam (227)	■	■	■		
Light Silk (261)		■	■		
Light Turquoise (263)	■	■	■	■	
Mocca (286)		■	■		
Padparadscha (542)		■	■		
Peridot (214)		■	■		
Purple Velvet (277)		■	■		
Rose Peach (262)		■	■		
Siam (208)	■	■	■		
Silk (391)		■	■		
Tangerine (259)	■	■	■		
Tanzanite (539)		■	■		
Vintage Rose (319)		■	■		
Violet (371)		■	■		
Crystal Blend Colors					
Burgundy-Blue Zircon Blend (723)			■		
Crystal-Montana Blend (725)		■	■	■	
Fern Green-Topaz Blend (724)			■		
Provence Lavender-Chrysolite Blend (726)	■	■	■		

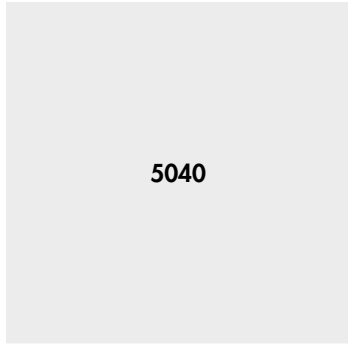

Size	4 mm	6 mm	8 mm	12 mm	18 mm
------	------	------	------	-------	-------

Crystal Effects

Transparent Effects

Crystal AB (001 AB)	■	■	■	■	■
Crystal Antique Pink (001 ANTP)		■	■	■	
Crystal Astral Pink (001 API)	■	■	■	■	■
Crystal Blue Shade (001 BLSH)	■	■	■	■	■
Crystal Bronze Shade (001 BRSH)	■	■	■	■	■
Crystal Copper (001 COP)	■	■	■	■	
Crystal Golden Shadow (001 GSHA)	■	■	■	■	
Crystal Lilac Shadow (001 LISH)	■	■	■	■	
Crystal Luminous Green (001 LUMG)		■	■	■	
Crystal Moonlight (001 MOL)		■	■		
Crystal Red Magma (001 REDM)	■	■	■	■	
Crystal Silver Night (001 SINI)	■	■	■	■	
Crystal Silver Shade (001 SSHA)	■	■	■	■	
Transparent Effects					
Crystal Iridescent Green (001 IRIG)	■	■	■		

Beads

5041 Briolette Bead (large hole)

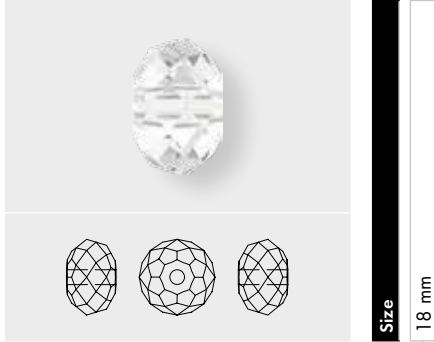

Size

18 mm

Crystal

Crystal (001)

Crystal Effects

Transparent Effects

Crystal AB (001 AB)

Crystal Astral Pink (001 API)

Crystal Golden Shadow (001 GSHA)

Crystal Silver Shade (001 SSHA)

5050 Oval Bead

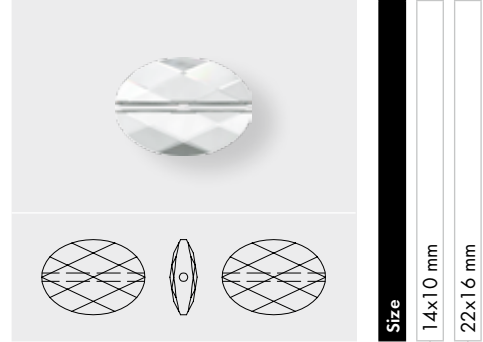

Size

14x10 mm

22x16 mm

Crystal

Crystal (001)

Colors

Plain Colors

Jet (280)

Light Turquoise (263)

Crystal Blend Colors

Provence Lavender-Chrysolite Blend (726)

Crystal Effects

Transparent Effects

Crystal AB (001 AB)

Crystal Blue Shade (001 BLSH)

Crystal Golden Shadow (001 GSHA)

Crystal Lilac Shadow (001 LISH)

Crystal Vitrail Medium P (001 VM)*

Metallic Effects

Crystal Comet Argent Light P (001 CAL)*

Crystal Rose Gold (001 ROGL)

Crystal Rose Gold 2x (001 ROGL2)

* For details about the „protective layer“ please refer to page 24.

Beads

5051 Mini Oval Bead

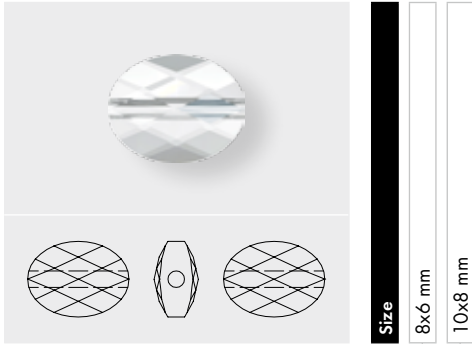

Size
8x6 mm
10x8 mm

Crystal	
Crystal (001)	<input type="checkbox"/>
Colors	
Plain Colors	
Amethyst (204)	<input type="checkbox"/>
Aquamarine (202)	<input type="checkbox"/>
Black Diamond (215)	<input type="checkbox"/>
Dark Moss Green (260)	<input type="checkbox"/>
Emerald (205)	<input type="checkbox"/>
Fern Green (291)	<input type="checkbox"/>
Indicolite (379)	<input type="checkbox"/>
Jet (280)	<input type="checkbox"/>
Light Silk (261)	<input type="checkbox"/>
Light Turquoise (263)	<input type="checkbox"/>
Montana (207)	<input type="checkbox"/>
Rose (209)	<input type="checkbox"/>
Siam (208)	<input type="checkbox"/>
Smoked Topaz (220)	<input type="checkbox"/>
Sunflower (292)	<input type="checkbox"/>
Tangerine (259)	<input type="checkbox"/>
Tanzanite (539)	<input type="checkbox"/>
Crystal Effects	
Transparent Effects	
Crystal AB (001 AB)	<input type="checkbox"/>
Crystal Antique Pink (001 ANTP)	<input type="checkbox"/>
Crystal Blue Shade (001 BLSH)	<input type="checkbox"/>
Crystal Bronze Shade (001 BRSH)	<input type="checkbox"/>
Crystal Golden Shadow (001 GSHA)	<input type="checkbox"/>
Crystal Lilac Shadow (001 LISH)	<input type="checkbox"/>
Crystal Red Magma (001 REDM)	<input type="checkbox"/>
Crystal Silver Night (001 SINI)	<input type="checkbox"/>
Crystal Silver Shade (001 SSHA)	<input type="checkbox"/>
Metallic Effects	
Crystal Iridescent Green (001 IRIG)	<input type="checkbox"/>
Crystal Rose Gold (001 ROGL)	<input type="checkbox"/>
Crystal Rose Gold 2x (001 ROGL2)	<input type="checkbox"/>

5052 Mini Round Bead

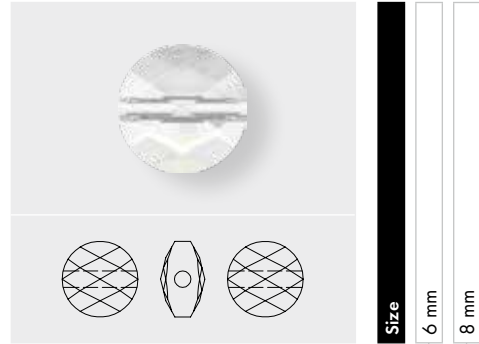

Size
6 mm
8 mm

Crystal	
Crystal (001)	<input type="checkbox"/>
Colors	
Plain Colors	
Amethyst (204)	<input type="checkbox"/>
Aquamarine (202)	<input type="checkbox"/>
Black Diamond (215)	<input type="checkbox"/>
Dark Moss Green (260)	<input type="checkbox"/>
Emerald (205)	<input type="checkbox"/>
Fern Green (291)	<input type="checkbox"/>
Indicolite (379)	<input type="checkbox"/>
Jet (280)	<input type="checkbox"/>
Light Silk (261)	<input type="checkbox"/>
Light Turquoise (263)	<input type="checkbox"/>
Montana (207)	<input type="checkbox"/>
Rose (209)	<input type="checkbox"/>
Siam (208)	<input type="checkbox"/>
Smoked Topaz (220)	<input type="checkbox"/>
Sunflower (292)	<input type="checkbox"/>
Tangerine (259)	<input type="checkbox"/>
Tanzanite (539)	<input type="checkbox"/>
Crystal Effects	
Transparent Effects	
Crystal AB (001 AB)	<input type="checkbox"/>
Crystal Antique Pink (001 ANTP)	<input type="checkbox"/>
Crystal Blue Shade (001 BLSH)	<input type="checkbox"/>
Crystal Bronze Shade (001 BRSH)	<input type="checkbox"/>
Crystal Golden Shadow (001 GSHA)	<input type="checkbox"/>
Crystal Lilac Shadow (001 LISH)	<input type="checkbox"/>
Crystal Red Magma (001 REDM)	<input type="checkbox"/>
Crystal Silver Night (001 SINI)	<input type="checkbox"/>
Crystal Silver Shade (001 SSHA)	<input type="checkbox"/>
Metallic Effects	
Crystal Iridescent Green (001 IRIG)	<input type="checkbox"/>
Crystal Rose Gold (001 ROGL)	<input type="checkbox"/>
Crystal Rose Gold 2x (001 ROGL2)	<input type="checkbox"/>

Beads

5053 Mini Square Bead

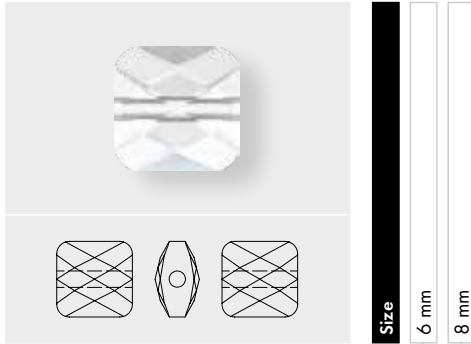

Crystal	
Crystal (001)	■ ■
Colors	
Plain Colors	
Amethyst (204)	■ ■
Aquamarine (202)	■ ■
Black Diamond (215)	■ ■
Dark Moss Green (260)	■ ■
Emerald (205)	■ ■
Fern Green (291)	■ ■
Indicolite (379)	■ ■
Jet (280)	■ ■
Light Silk (261)	■ ■
Light Turquoise (263)	■ ■
Montana (207)	■ ■
Rose (209)	■ ■
Siam (208)	■ ■
Smoked Topaz (220)	■ ■
Sunflower (292)	■ ■
Tangerine (259)	■ ■
Tanzanite (539)	■ ■
Crystal Effects	
Transparent Effects	
Crystal AB (001 AB)	■ ■
Crystal Antique Pink (001 ANTP)	■ ■
Crystal Blue Shade (001 BLSH)	■ ■
Crystal Bronze Shade (001 BRSH)	■ ■
Crystal Golden Shadow (001 GSHA)	■ ■
Crystal Lilac Shadow (001 LISH)	■ ■
Crystal Red Magma (001 REDM)	■ ■
Crystal Silver Night (001 SINI)	■ ■
Crystal Silver Shade (001 SSHA)	■ ■
Metallic Effects	
Crystal Iridescent Green (001 IRIG)	■ ■
Crystal Rose Gold (001 ROGL)	■ ■
Crystal Rose Gold 2x (001 ROGL2)	■ ■

5054 Mini Rhombus Bead

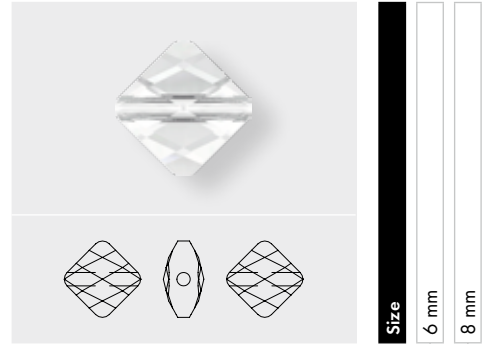

Crystal	
Crystal (001)	■ ■
Colors	
Plain Colors	
Dark Moss Green (260)	■ ■
Indicolite (379)	■ ■
Jet (280)	■ ■
Light Silk (261)	■ ■
Light Turquoise (263)	■ ■
Rose (209)	■ ■
Siam (208)	■ ■
Tangerine (259)	■ ■
Crystal Effects	
Transparent Effects	
Crystal AB (001 AB)	■ ■
Crystal Antique Pink (001 ANTP)	■ ■
Crystal Blue Shade (001 BLSH)	■ ■
Crystal Bronze Shade (001 BRSH)	■ ■
Crystal Golden Shadow (001 GSHA)	■ ■
Crystal Lilac Shadow (001 LISH)	■ ■
Crystal Red Magma (001 REDM)	■ ■
Crystal Silver Night (001 SINI)	■ ■
Crystal Silver Shade (001 SSHA)	■ ■
Metallic Effects	
Crystal Iridescent Green (001 IRIG)	■ ■
Crystal Rose Gold (001 ROGL)	■ ■

Beads

5055 Mini Rectangle Bead

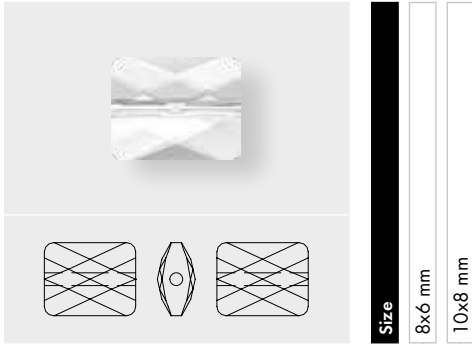

Size

8x6 mm

10x8 mm

Crystal

Crystal (001)

Colors

Plain Colors

- Dark Moss Green (260)
- Indicolite (379)
- Jet (280)
- Light Silk (261)
- Light Turquoise (263)
- Rose (209)
- Siam (208)
- Tangerine (259)

Crystal Effects

Transparent Effects

- Crystal AB (001 AB)
- Crystal Antique Pink (001 ANTP)
- Crystal Blue Shade (001 BLSH)
- Crystal Bronze Shade (001 BRSH)
- Crystal Golden Shadow (001 GSHA)
- Crystal Lilac Shadow (001 LISH)
- Crystal Red Magma (001 REDM)
- Crystal Silver Night (001 SINI)
- Crystal Silver Shade (001 SSHA)

Metallic Effects

- Crystal Iridescent Green (001 IRIG)
- Crystal Rose Gold (001 ROGL)

5056 Mini Drop Bead

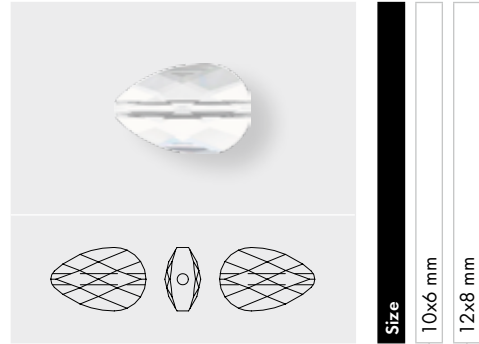

Size

10x6 mm

12x8 mm

Crystal

Crystal (001)

Colors

Plain Colors

- Dark Moss Green (260)
- Indicolite (379)
- Jet (280)
- Light Silk (261)
- Light Turquoise (263)
- Rose (209)
- Siam (208)
- Tangerine (259)

Crystal Effects

Transparent Effects

- Crystal AB (001 AB)
- Crystal Antique Pink (001 ANTP)
- Crystal Blue Shade (001 BLSH)
- Crystal Bronze Shade (001 BRSH)
- Crystal Golden Shadow (001 GSHA)
- Crystal Lilac Shadow (001 LISH)
- Crystal Red Magma (001 REDM)
- Crystal Silver Night (001 SINI)
- Crystal Silver Shade (001 SSHA)

Metallic Effects

- Crystal Iridescent Green (001 IRIG)
- Crystal Rose Gold (001 ROGL)

Beads

5139 Ring Bead

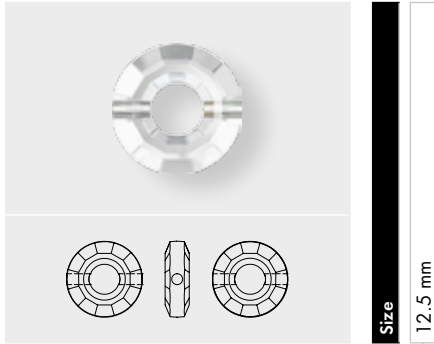

Size

12.5 mm

Crystal

Crystal (001)

Colors

Plain Colors

Light Turquoise (263)

Crystal Effects

Transparent Effects

Crystal AB (001 AB)

Crystal Astral Pink (001 API)

Crystal Golden Shadow (001 GSHA)

Crystal Silver Night (001 SINI)

Metallic Effects

Crystal Rose Gold (001 ROGL)

Crystal Rose Gold 2x (001 ROGL2)

5181 Keystone Bead (two holes)

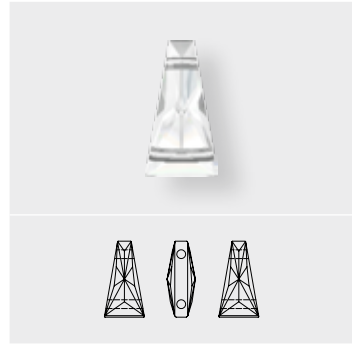

Size

13x7 mm

17x9 mm

Crystal

Crystal (001)

Colors

Plain Colors

Jet (280)

Crystal Effects

Transparent Effects

Crystal AB (001 AB)

Crystal Golden Shadow (001 GSHA)

5200



Size

6x4 mm

7.5x5 mm

Crystal

Crystal (001)

Colors

Plain Colors

Jet (280)

Crystal Effects

Transparent Effects

Crystal AB (001 AB)

5203 Polygon Bead

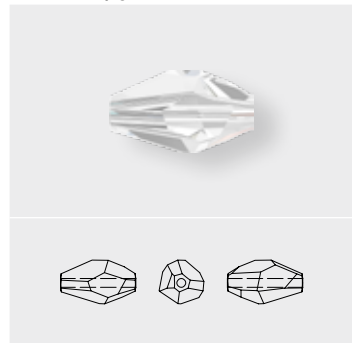

Size

12x8 mm

Crystal

Crystal (001)

Crystal Effects

Transparent Effects

Crystal AB (001 AB)

Beads

5305

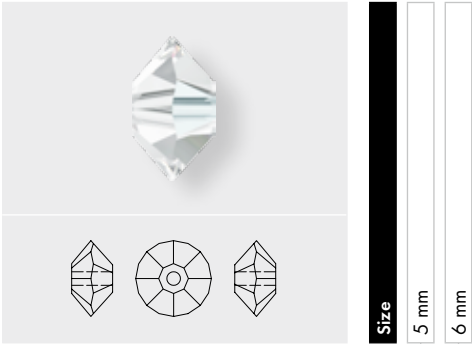

Size
5 mm
6 mm

- Crystal**
- Crystal (001)
- Colors**
- Plain Colors
- Jet (280)
- Crystal Effects**
- Transparent Effects
- Crystal AB (001 AB)

5308

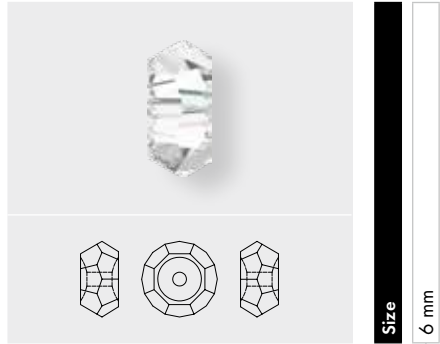

Size
6 mm

- Crystal**
- Crystal (001)
- Crystal Effects**
- Transparent Effects
- Crystal AB (001 AB)

Beads

5328 XILION Bead

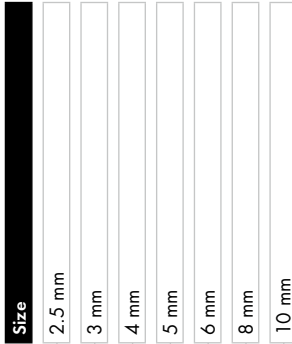

Crystal

Crystal (001)

Colors

Plain Colors

- Amethyst (204)
- Aquamarine (202)
- Black Diamond (215)
- Blue Zircon (229)
- Burgundy (515)
- Capri Blue (243)
- Chrysolite (238)
- Citrine (249)
- Dark Indigo (288)
- Dark Moss Green (260)
- Denim Blue (266)
- Emerald (205)
- Erinite (360)
- Fern Green (291)
- Fireopal (237)
- Fuchsia (502)
- Garnet (241)
- Greige (284)
- Hyacinth (236)
- Indian Pink (289)
- Indian Sapphire (217)
- Indicolite (379)
- Jet (280)
- Jonquil (213)
- Khaki (550)
- Light Amethyst (212)
- Light Azore (361)
- Light Colorado Topaz (246)
- Light Peach (362)
- Light Rose (223)
- Light Sapphire (211)
- Light Siam (227)
- Light Silk (261)
- Light Smoked Topaz (221)
- Light Topaz (226)
- Light Turquoise (263)
- Mocca (286)

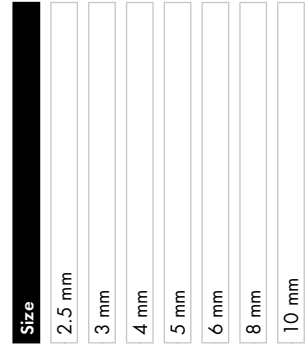
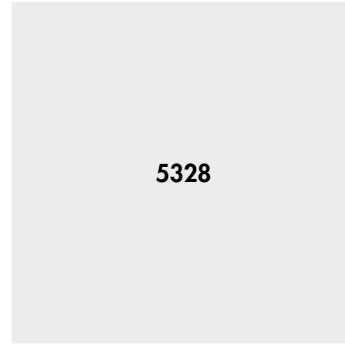

- Montana (207)
 - Olivine (228)
 - Padparadscha (542)
 - Peridot (214)
 - Provence Lavender (283)
 - Purple Velvet (277)
 - Rosaline (508)
 - Rose (209)
 - Rose Peach (262)
 - Ruby (501)
 - Sapphire (206)
 - Siam (208)
 - Silk (391)
 - Smoked Topaz (220)
 - Smoky Quartz (225)
 - Sun (248)
 - Sunflower (292)
 - Tangerine (259)
 - Tanzanite (539)
 - Topaz (203)
 - Turquoise (267)
 - Vintage Rose (319)
 - Violet (371)
 - White Alabaster (281)
- #### Opal Colors
- Air Blue Opal (285)
 - Caribbean Blue Opal (394)
 - Chrysolite Opal (294)
 - Cyclamen Opal (398)
 - Light Grey Opal (383)
 - Pacific Opal (390)
 - Palace Green Opal (393)
 - Rose Water Opal (395)
 - Sand Opal (287)
 - White Opal (234)
- #### Crystal Blend Colors
- Burgundy-Blue Zircon Blend (723)
 - Crystal-Montana Blend (725)
 - Fern Green-Topaz Blend (724)
 - Provence Lavender-Chrysolite Blend (726)

Beads

04 Beads

5328		Size	2.5 mm	3 mm	4 mm	5 mm	6 mm	8 mm	10 mm
Crystal Effects									
Transparent Effects									
Crystal AB (001 AB)			■	■	■	■	■	■	■
Crystal AB 2x (001 AB2)				■	■	■	■		
Crystal AB Satin (001 ABSAT)				■	■				
Crystal Antique Pink (001 ANTP)				■	■	■	■		
Crystal Astral Pink (001 API)				■	■	■	■		
Crystal Blue Shade (001 BLSH)				■	■	■	■	■	■
Crystal Bronze Shade (001 BRSH)				■	■				
Crystal Copper (001 COP)				■	■	■	■		
Crystal Golden Shadow (001 GSHA)		■	■	■	■	■	■	■	
Crystal Heliotrope (001 HEL)			■	■					
Crystal Lilac Shadow (001 LISH)			■	■	■	■	■	■	
Crystal Luminous Green (001 LUMG)			■	■	■	■			
Crystal Moonlight (001 MOL)			■	■	■	■			
Crystal Red Magma (001 REDM)			■	■	■	■			
Crystal Satin (001 SAT)			■	■	■	■			
Crystal Silver Night (001 SINI)			■	■	■	■			
Crystal Silver Shade (001 SSHA)		■	■	■	■	■	■	■	
Crystal Vitrail Medium (001 VM)			■	■		■			
Metallic Effects									
Crystal CAL (001 CAL)			■	■	■	■			
Crystal Dorado 2x (001 DOR2)			■	■	■	■			
Crystal Iridescent Green (001 IRIG)			■	■	■	■			
Crystal Iridescent Green 2x (001 IRIG2)				■					
Crystal Metallic Blue 2x (001 METBL2)			■	■	■	■			
Crystal Metallic Light Gold 2x (001 MLG2)			■	■	■	■			
Crystal Rose Gold (001 ROGL)			■	■	■	■			
Crystal Rose Gold 2x (001 ROGL2)			■	■	■	■			
Color Effects									
Transparent Effects									
Amethyst AB (204 AB)			■	■	■	■			
Amethyst AB 2x (204 AB2)				■					
Aquamarine AB (202 AB)			■	■	■	■			
Aquamarine AB 2x (202 AB2)				■					
Aquamarine Satin (202 SAT)			■	■					
Black Diamond AB (215 AB)			■	■	■	■			
Black Diamond AB 2x (215 AB2)				■					
Blue Zircon AB (229 AB)			■	■					
Blue Zircon AB 2x (229 AB2)				■					
Capri Blue AB (243 AB)			■	■					

5328		Size	2.5 mm	3 mm	4 mm	5 mm	6 mm	8 mm	10 mm
Capri Blue AB 2x (243 AB2)					■				
Chrysolite AB (238 AB)					■				
Chrysolite AB 2x (238 AB2)					■				
Dark Moss Green AB (260 AB)					■				
Dark Moss Green AB 2x (260 AB2)					■				
Emerald AB (205 AB)				■	■				
Emerald AB 2x (205 AB2)					■				
Erinte AB (360 AB)					■				
Fireopal AB (237 AB)					■				
Fireopal AB 2x (237 AB2)					■				
Fuchsia AB (502 AB)				■	■				
Fuchsia AB 2x (502 AB2)					■				
Hyacinth AB (236 AB)					■				
Hyacinth AB 2x (236 AB2)					■				
Indian Sapphire AB (217 AB)					■				
Indicolite AB (379 AB)								■	
Jet AB (280 AB)				■	■	■	■		
Jet AB 2x (280 AB2)				■	■	■	■		
Jonquil AB (213 AB)							■		
Jonquil AB 2x (213 AB2)							■		
Jonquil Satin (213 SAT)							■		
Light Amethyst AB (212 AB)				■	■				
Light Amethyst AB 2x (212 AB2)					■				
Light Azore AB (361 AB)					■				
Light Azore AB 2x (361 AB2)					■				
Light Colorado Topaz AB (246 AB)				■	■	■	■		
Light Colorado Topaz AB 2x (246 AB2)					■				
Light Peach AB (362 AB)					■				
Light Peach Satin (362 SAT)					■				
Light Rose AB (223 AB)				■	■	■	■		
Light Rose AB 2x (223 AB2)					■				
Light Rose Satin (223 SAT)					■				
Light Sapphire AB (211 AB)				■	■				
Light Sapphire AB 2x (211 AB2)					■				
Light Siam AB (227 AB)				■	■	■	■		
Light Siam AB 2x (227 AB2)					■				
Light Siam Satin (227 SAT)					■				
Light Smoked Topaz AB (221 AB)					■				
Light Topaz AB (226 AB)					■				
Light Topaz AB 2x (226 AB2)					■				
Montana AB (207 AB)				■	■				

Beads

5328	Size	2.5 mm	3 mm	4 mm	5 mm	6 mm	8 mm	10 mm
	Montana AB 2x (207 AB2)				■			
Olivine AB (228 AB)			■	■				
Pacific Opal AB 2x (390 AB2)				■				
Peridot AB (214 AB)				■				
Peridot AB 2x (214 AB2)				■				
Purple Velvet AB (277 AB)				■				
Rose AB (209 AB)			■	■	■	■		
Rose AB 2x (209 AB2)				■				
Rose Satin (209 SAT)				■				
Rose Water Opal AB 2x (395 AB2)				■				
Ruby AB (501 AB)				■				
Sapphire AB (206 AB)			■	■				
Sapphire AB 2x (206 AB2)				■				
Siam AB (208 AB)				■	■			
Siam AB 2x (208 AB2)				■				
Smoked Topaz AB (220 AB)				■				
Sun AB 2x (248 AB2)				■				
Tangerine AB (259 AB)				■				
Tangerine AB 2x (259 AB2)				■				
Tanzanite AB (539 AB)			■	■	■	■		
Tanzanite AB 2x (539 AB2)				■				
Topaz AB (203 AB)				■				
Topaz AB 2x (203 AB2)				■				
Turquoise AB (267 AB)			■	■				
Turquoise AB 2x (267 AB2)				■				
Violet AB (371 AB)			■	■		■		
Violet AB 2x (371 AB2)				■				
White Alabaster AB 2x (281 AB2)				■				
White Opal AB (234 AB)			■	■				
White Opal AB 2x (234 AB2)				■				
Metallic Effects								
Jet Hematite (280 HEM)			■	■	■	■		
Jet Hematite 2x (280 HEM2)			■	■	■	■		
Jet Nut 2x (280 NUT2)			■	■				

Beads

5500

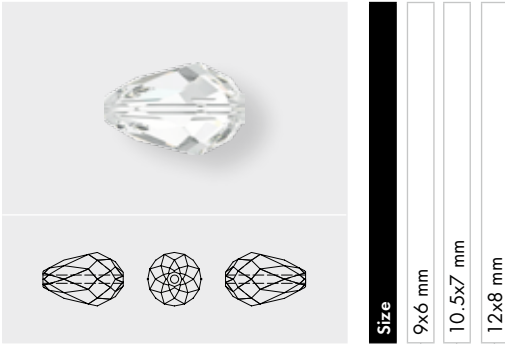

Size
9x6 mm
10.5x7 mm
12x8 mm

- Crystal**
- Crystal (001)
- Colors**
- Plain Colors
- Jet (280)
- Siam (208)
- Crystal Effects**
- Transparent Effects
- Crystal AB (001 AB)

5520 Graphic Bead

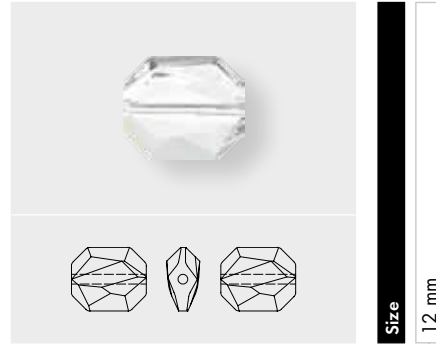

Size
12 mm

- Crystal**
- Crystal (001)
- Colors**
- Plain Colors
- Jet (280)
- Crystal Effects**
- Transparent Effects
- Crystal AB (001 AB)
- Crystal Golden Shadow (001 GSHA)

5523 Cosmic Bead

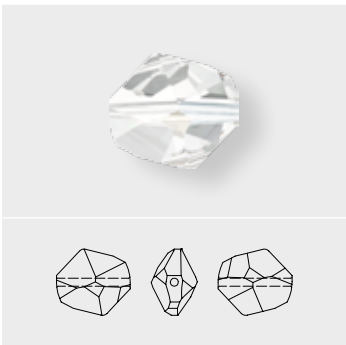

Size
12 mm
16 mm

- Crystal**
- Crystal (001)
- Colors**
- Plain Colors
- Jet (280)
- Crystal Effects**
- Transparent Effects
- Crystal AB (001 AB)
- Crystal Astral Pink (001 API)
- Crystal Golden Shadow (001 GSHA)

5535 Column Bead (two holes)

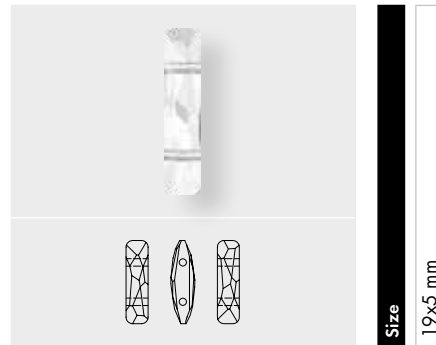

Size
19x5 mm
23.5x5 mm

- Crystal**
- Crystal (001)
- Colors**
- Plain Colors
- Dark Moss Green (260)
- Crystal Effects**
- Transparent Effects
- Crystal AB (001 AB)
- Crystal Lilac Shadow (001 LISH)
- Metallic Effects**
- Crystal Rose Gold (001 ROGL)
- Crystal Rose Gold 2x (001 ROGL2)

Beads

5540 Artemis Bead

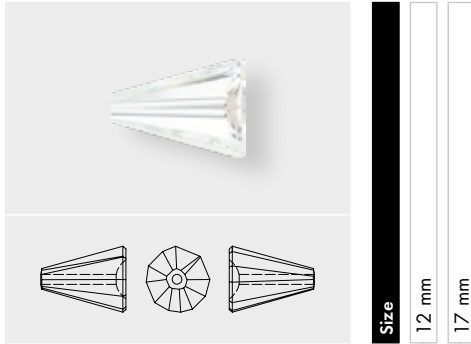

Crystal	
<input type="checkbox"/> Crystal (001)	<input type="checkbox"/>
Colors	
Plain Colors	
<input type="checkbox"/> Amethyst (204)	<input type="checkbox"/>
<input type="checkbox"/> Aquamarine (202)	<input type="checkbox"/>
<input type="checkbox"/> Dark Indigo (288)	<input type="checkbox"/>
<input type="checkbox"/> Dark Moss Green (260)	<input type="checkbox"/>
<input type="checkbox"/> Jet (280)	<input type="checkbox"/>
<input type="checkbox"/> Olivine (228)	<input type="checkbox"/>
Crystal Effects	
Transparent Effects	
<input type="checkbox"/> Crystal AB (001 AB)	<input type="checkbox"/>
<input type="checkbox"/> Crystal Astral Pink (001 API)	<input type="checkbox"/>
<input type="checkbox"/> Crystal Copper (001 COP)	<input type="checkbox"/>
<input type="checkbox"/> Crystal Golden Shadow (001 GSHA)	<input type="checkbox"/>
<input type="checkbox"/> Crystal Lilac Shadow (001 LISH)	<input type="checkbox"/>
Metallic Effects	
<input type="checkbox"/> Crystal Rose Gold (001 ROGL)	<input type="checkbox"/>
Color Effects	
Metallic Effects	
<input type="checkbox"/> Jet Hematite (280 HEM)	<input type="checkbox"/>

5541 Dome Bead large

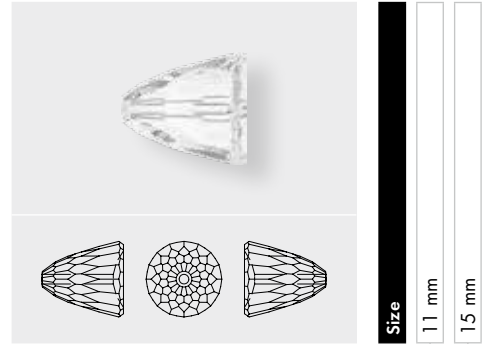

Crystal	
<input type="checkbox"/> Crystal (001)	<input type="checkbox"/>
Colors	
Plain Colors	
<input type="checkbox"/> Amethyst (204)	<input type="checkbox"/>
<input type="checkbox"/> Dark Indigo (288)	<input type="checkbox"/>
<input type="checkbox"/> Dark Moss Green (260)	<input type="checkbox"/>
<input type="checkbox"/> Fuchsia (502)	<input type="checkbox"/>
<input type="checkbox"/> Jet (280)	<input type="checkbox"/>
<input type="checkbox"/> Light Rose (223)	<input type="checkbox"/>
Crystal Effects	
Transparent Effects	
<input type="checkbox"/> Crystal AB (001 AB)	<input type="checkbox"/>
<input type="checkbox"/> Crystal Antique Pink (001 ANTP)	<input type="checkbox"/>
<input type="checkbox"/> Crystal Astral Pink (001 API)	<input type="checkbox"/>
<input type="checkbox"/> Crystal Blue Shade (001 BLSH)	<input type="checkbox"/>
<input type="checkbox"/> Crystal Bronze Shade (001 BRSH)	<input type="checkbox"/>
<input type="checkbox"/> Crystal Golden Shadow (001 GSHA)	<input type="checkbox"/>
<input type="checkbox"/> Crystal Lilac Shadow (001 LISH)	<input type="checkbox"/>
<input type="checkbox"/> Crystal Red Magma (001 REDM)	<input type="checkbox"/>
<input type="checkbox"/> Crystal Silver Shade (001 SSHA)	<input type="checkbox"/>
Metallic Effects	
<input type="checkbox"/> Crystal Rose Gold (001 ROGL)	<input type="checkbox"/>
Color Effects	
Metallic Effects	
<input type="checkbox"/> Jet Hematite (280 HEM)	<input type="checkbox"/>

Beads

5542 Dome Bead small

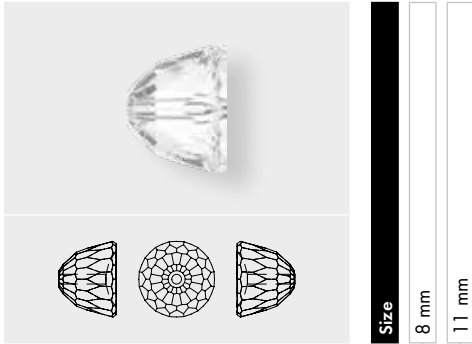

Size	8 mm	11 mm
------	------	-------

Crystal		
Crystal (001)	■	■
Colors		
Plain Colors		
Amethyst (204)	■	■
Dark Indigo (288)	■	■
Dark Moss Green (260)	■	■
Fuchsia (502)	■	■
Jet (280)	■	■
Light Rose (223)	■	■
Crystal Effects		
Transparent Effects		
Crystal AB (001 AB)	■	■
Crystal Antique Pink (001 ANTP)	■	■
Crystal Astral Pink (001 API)	■	■
Crystal Blue Shade (001 BLSH)	■	■
Crystal Bronze Shade (001 BRSH)	■	■
Crystal Golden Shadow (001 GSHA)	■	■
Crystal Lilac Shadow (001 LISH)	■	■
Crystal Red Magma (001 REDM)	■	■
Crystal Silver Shade (001 SSHA)	■	■
Metallic Effects		
Crystal Rose Gold (001 ROGL)	■	■
Color Effects		
Metallic Effects		
Jet Hematite (280 HEM)	■	■

5601



Size	4 mm	6 mm	8 mm	10 mm	12 mm
------	------	------	------	-------	-------

Crystal					
Crystal (001)	■	■	■	■	■
Colors					
Plain Colors					
Amethyst (204)	■	■	■		
Aquamarine (202)	■	■	■		
Dark Moss Green (260)	■	■	■		
Emerald (205)	■	■	■		
Fuchsia (502)		■	■		
Jet (280)		■	■		
Light Siam (227)		■	■		
Light Topaz (226)		■	■		
Light Turquoise (263)	■	■	■		
Peridot (214)	■	■	■		
Sapphire (206)	■	■	■		
Siam (208)	■	■	■		
Tangerine (259)	■	■			
Tanzanite (539)	■	■	■		
Topaz (203)	■	■	■		
Crystal Effects					
Transparent Effects					
Crystal AB B (001 ABB)	■	■	■	■	■
Crystal Blue Shade B (001 BLSHB)	■	■	■		
Crystal Golden Shadow B (001 GSHAB)	■	■	■		
Crystal Lilac Shadow B (001 LISHB)	■	■	■		
Crystal Luminous Green B (001 LUMGB)	■	■	■		
Crystal Silver Night B (001 SINIB)	■	■	■		
Crystal Vitrail Medium B (001 VMB)	■	■	■		
Metallic Effects					
Crystal Rose Gold B (001 ROGLB)	■	■	■		
Crystal Rose Gold B 2x (001 ROGL2B)	■	■	■		

Beads

5603 Graphic Cube Bead

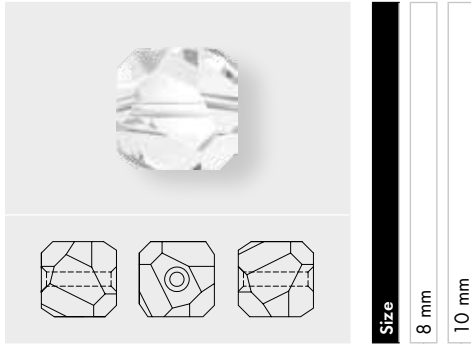

Crystal	
Crystal (001)	
Crystal Effects	
Transparent Effects	
Crystal AB (001 AB)	
Crystal Golden Shadow (001 GSHA)	

5621 Twist Bead

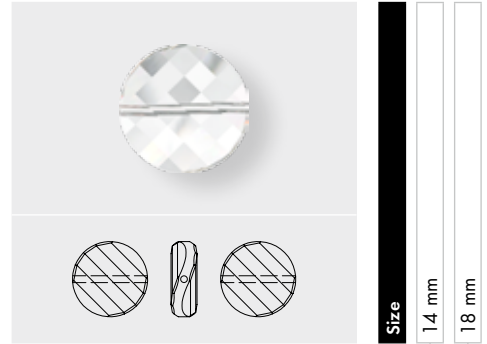

Crystal	
Crystal (001)	
Colors	
Plain Colors	
Amethyst (204)	
Aquamarine (202)	
Black Diamond (215)	
Jet (280)	
Crystal Effects	
Transparent Effects	
Crystal Astral Pink (001 API)	
Crystal Golden Shadow (001 GSHA)	
Crystal Silver Night (001 SINI)	
Crystal Vitrail Medium P (001 VM)*	
Metallic Effects	
Crystal Comet Argent Light P (001 CAL)*	

* For details about the „protective layer“ please refer to page 24.

Beads

5624 Stairway Bead

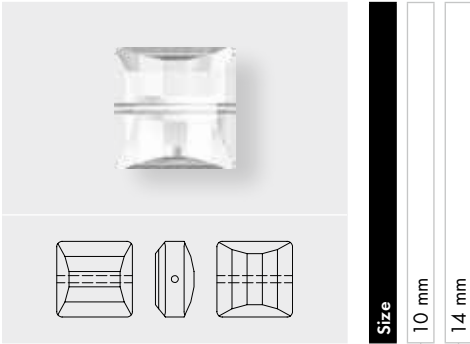

Crystal	
<input type="checkbox"/>	Crystal (001)
Colors	
Plain Colors	
<input type="checkbox"/>	Amethyst (204)
<input type="checkbox"/>	Denim Blue (266)
<input type="checkbox"/>	Jet (280)
<input type="checkbox"/>	Light Smoked Topaz (221)
Crystal Effects	
Transparent Effects	
<input type="checkbox"/>	Crystal AB (001 AB)
<input type="checkbox"/>	Crystal Astral Pink (001 API)
<input type="checkbox"/>	Crystal Blue Shade (001 BLSH)
<input type="checkbox"/>	Crystal Golden Shadow (001 GSHA)
<input type="checkbox"/>	Crystal Lilac Shadow (001 LISH)
<input type="checkbox"/>	Crystal Red Magma (001 REDM)
Metallic Effects	
<input type="checkbox"/>	Crystal Iridescent Green (001 IRIG)

5625 Stairway Bead (two holes)

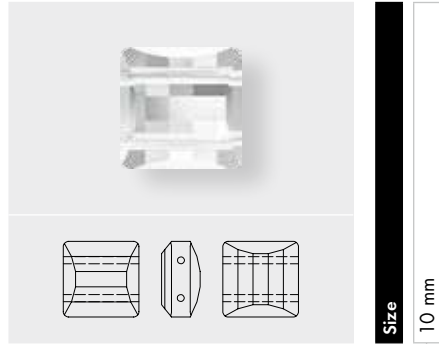

Crystal	
<input type="checkbox"/>	Crystal (001)
Colors	
Plain Colors	
<input type="checkbox"/>	Amethyst (204)
<input type="checkbox"/>	Aquamarine (202)
<input type="checkbox"/>	Black Diamond (215)
<input type="checkbox"/>	Dark Moss Green (260)
<input type="checkbox"/>	Jet (280)
<input type="checkbox"/>	Jonquil (213)
<input type="checkbox"/>	Light Smoked Topaz (221)
<input type="checkbox"/>	Peridot (214)
<input type="checkbox"/>	Rosaline (508)
Opal Colors	
<input type="checkbox"/>	White Opal (234)
Crystal Effects	
Transparent Effects	
<input type="checkbox"/>	Crystal AB (001 AB)
<input type="checkbox"/>	Crystal Blue Shade (001 BLSH)
<input type="checkbox"/>	Crystal Copper (001 COP)
<input type="checkbox"/>	Crystal Golden Shadow (001 GSHA)
<input type="checkbox"/>	Crystal Lilac Shadow (001 LISH)
<input type="checkbox"/>	Crystal Red Magma (001 REDM)
<input type="checkbox"/>	Crystal Silver Shade (001 SSHA)
Metallic Effects	
<input type="checkbox"/>	Crystal Iridescent Green (001 IRIG)

Beads

5650 Cubist Bead

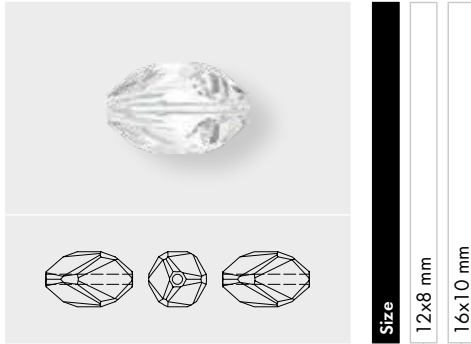

- Size**
12x8 mm
16x10 mm
- Crystal**
- Crystal (001)
- Crystal Effects**
- Transparent Effects**
- Crystal AB (001 AB)
 - Crystal Golden Shadow (001 GSHA)

5714 Star Bead

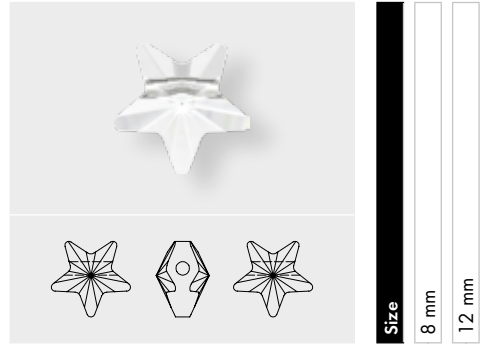

- Size**
8 mm
12 mm
- Crystal**
- Crystal (001)
- Colors**
- Plain Colors**
- Jet (280)
- Crystal Effects**
- Transparent Effects**
- Crystal AB (001 AB)
 - Crystal Golden Shadow (001 GSHA)

5727 Fish Bead

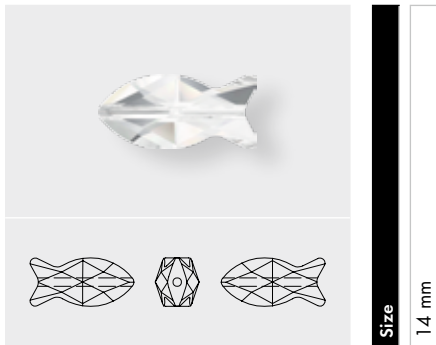

- Size**
14 mm
- Crystal**
- Crystal (001)
- Colors**
- Plain Colors**
- Light Turquoise (263)
- Crystal Effects**
- Transparent Effects**
- Crystal AB (001 AB)
 - Crystal Astral Pink (001 API)
 - Crystal Blue Shade (001 BLSH)
 - Crystal Golden Shadow (001 GSHA)

5742 Heart Bead

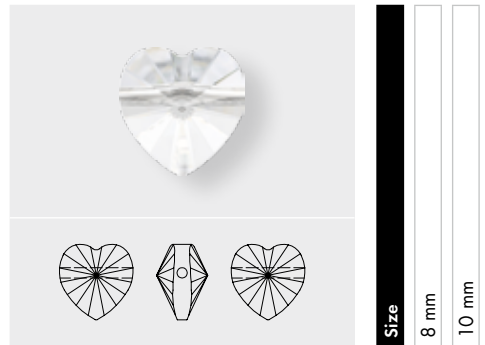

- Size**
8 mm
10 mm
- Crystal**
- Crystal (001)
- Crystal Effects**
- Transparent Effects**
- Crystal AB (001 AB)
 - Crystal Golden Shadow (001 GSHA)

Beads

5743 Wild Heart Bead



Size
12 mm
17 mm

- Crystal**
- Crystal (001)
- Colors**
- Plain Colors**
- Amethyst (204)
- Aquamarine (202)
- Siam (208)
- Crystal Effects**
- Transparent Effects**
- Crystal AB (001 AB)
- Crystal Golden Shadow (001 GSHA)

5744 Flower Bead

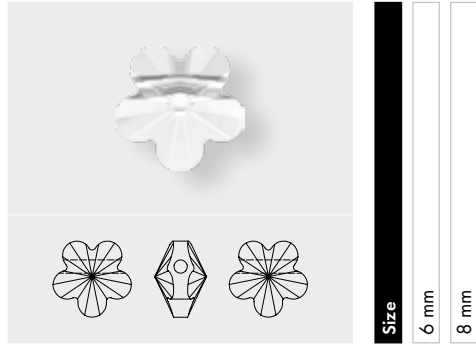

Size
6 mm
8 mm

- Crystal**
- Crystal (001)
- Colors**
- Plain Colors**
- Light Rose (223)
- Violet (371)
- Crystal Effects**
- Transparent Effects**
- Crystal AB (001 AB)

Beads

5747 Double Spike Bead

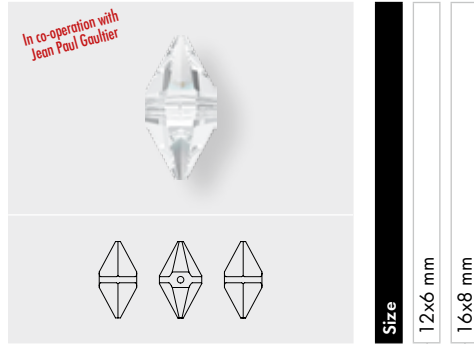

Crystal		
Crystal (001)	■	■
Colors		
Plain Colors		
Jet (280)	■	■
Light Turquoise (263)	■	■
Crystal Effects		
Transparent Effects		
Crystal AB (001 AB)	■	■
Crystal Astral Pink (001 API)	■	■
Crystal Golden Shadow (001 GSHA)	■	■
Crystal Lilac Shadow (001 LISH)	■	■
Crystal Luminous Green (001 LUMG)	■	■
Crystal Silver Night (001 SINI)	■	■
Crystal Silver Night 2x (001 SINI2)	■	■
Crystal Silver Shade (001 SSHA)	■	■
Metallic Effects		
Crystal Iridescent Green (001 IRIG)	■	■
Crystal Metallic Blue 2x (001 METBL2)	■	■
Crystal Metallic Light Gold 2x (001 MLG2)	■	■
Crystal Rose Gold 2x (001 ROGL2)	■	■

5750 Skull Bead

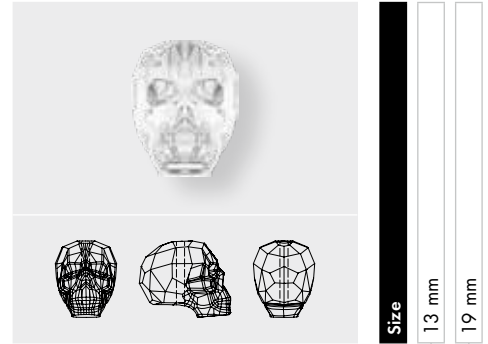

Crystal		
Crystal (001)	■	■
Colors		
Plain Colors		
Denim Blue (266)	■	■
Jet (280)	■	■
Sun (248)	■	■
Crystal Effects		
Transparent Effects		
Crystal AB (001 AB)	■	■
Crystal Astral Pink (001 API)	■	■
Crystal Golden Shadow (001 GSHA)	■	■
Crystal Luminous Green (001 LUMG)	■	■
Crystal Red Magma (001 REDM)	■	■
Crystal Silver Night (001 SINI)	■	■
Crystal Silver Night 2x (001 SINI2)	■	■
Metallic Effects		
Crystal Iridescent Green (001 IRIG)	■	■
Crystal Metallic Blue 2x (001 METBL2)	■	■
Crystal Metallic Light Gold 2x (001 MLG2)	■	■
Crystal Rose Gold 2x (001 ROGL2)	■	■

Beads

5752 Clover Bead

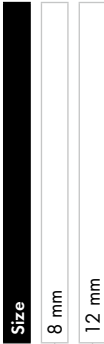
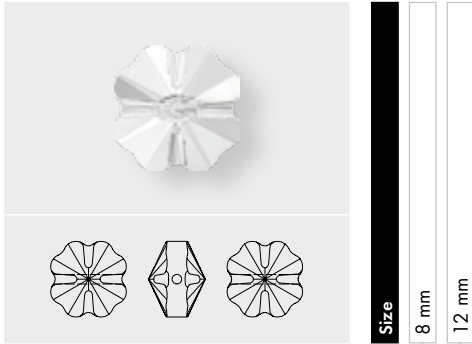

Crystal	
Crystal (001)	8 mm 12 mm
Colors	
Plain Colors	
Dark Moss Green (260)	8 mm 12 mm
Emerald (205)	8 mm 12 mm
Light Siam (227)	8 mm 12 mm
Peridot (214)	8 mm 12 mm
Crystal Effects	
Transparent Effects	
Crystal AB (001 AB)	8 mm 12 mm
Crystal Golden Shadow (001 GSHA)	8 mm 12 mm
Metallic Effects	
Crystal Iridescent Green (001 IRIG)	8 mm 12 mm

5754 Butterfly Bead

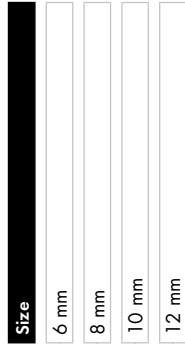
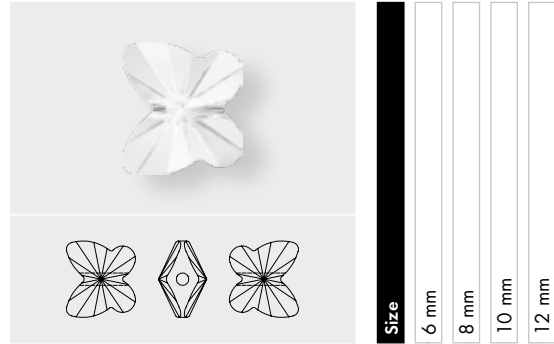

Crystal	
Crystal (001)	6 mm 8 mm 10 mm 12 mm
Colors	
Plain Colors	
Aquamarine (202)	6 mm 8 mm 10 mm 12 mm
Fuchsia (502)	6 mm 8 mm 10 mm 12 mm
Jet (280)	6 mm 8 mm 10 mm 12 mm
Jonquil (213)	6 mm 8 mm 10 mm 12 mm
Light Rose (223)	6 mm 8 mm 10 mm 12 mm
Light Siam (227)	6 mm 8 mm 10 mm 12 mm
Light Turquoise (263)	6 mm 8 mm 10 mm 12 mm
Peridot (214)	6 mm 8 mm 10 mm 12 mm
Rose Peach (262)	6 mm 8 mm 10 mm 12 mm
Tangerine (259)	6 mm 8 mm 10 mm 12 mm
Violet (371)	6 mm 8 mm 10 mm 12 mm
Crystal Blend Colors	
Amethyst Blend (721)	6 mm 8 mm 10 mm 12 mm
Provence Lavender-Chrysolite Blend (726)	6 mm 8 mm 10 mm 12 mm
Crystal Effects	
Transparent Effects	
Crystal AB (001 AB)	6 mm 8 mm 10 mm 12 mm
Crystal Astral Pink (001 API)	6 mm 8 mm 10 mm 12 mm
Crystal Copper (001 COP)	6 mm 8 mm 10 mm 12 mm
Crystal Golden Shadow (001 GSHA)	6 mm 8 mm 10 mm 12 mm
Crystal Silver Night (001 SINI)	6 mm 8 mm 10 mm 12 mm
Metallic Effects	
Crystal Iridescent Green (001 IRIG)	6 mm 8 mm 10 mm 12 mm
Crystal Metallic Light Gold 2x (001 MLG2)	6 mm 8 mm 10 mm 12 mm

Beads

5900 (large hole)

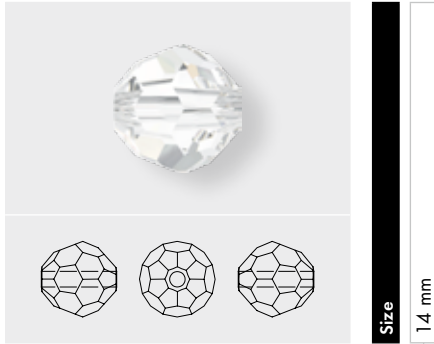

Crystal

Crystal (001)

Crystal Effects

Transparent Effects

Crystal AB (001 AB)

Crystal Blue Shade (001 BLSH)

Crystal Golden Shadow (001 GSHA)

5942 Heart Bead (large hole)

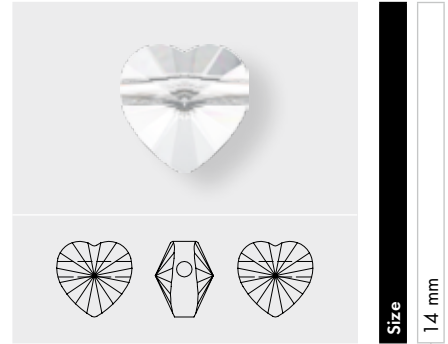

Crystal

Crystal (001)

Colors

Plain Colors

Jet (280)

Crystal Effects

Transparent Effects

Crystal AB (001 AB)

Crystal Bronze Shade (001 BRSH)

Crystal Red Magma (001 REDM)

ARTICLE EXPLANATION

40 512 Crystal Mesh Ball



S	12 mm	
M	12 PCS	100%

40 512	S	M	100%
Article Number	Size	Minimum Order Quantity in pieces (PCS)	Documentation size in %

EXPLANATION "COLOR COMBINATIONS"

All mentioned color combinations are preestablished in terms of

- Crystal color
- Crystal Pearl color
- Casing color

and are not modifiable. Within the available combinations you can choose from two different ring configurations.

ORDERING EXAMPLE & PRODUCT VARIETY EXPLANATION

40 512	082	001	001 650	0
Article number	Color of casing	Color of crystals	Color of Crystal Pearl	Ring configuration
		Please see the respective product matrix for available code reference	Please see the respective product matrix for available code reference	0 no jump ring 1 with 1 jump ring

AVAILABLE CRYSTAL MESH BALL COLORS & EFFECTS

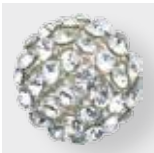

Crystal F (001)

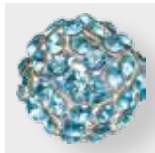

Aquamarine F (202)

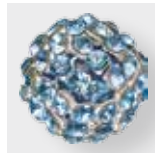

Denim Blue F (266)

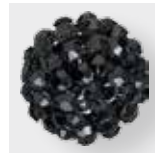

Jet (280)

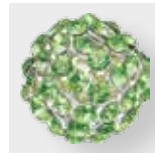

Peridot F (214)

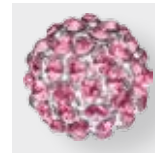

Rose F (209)



Smoky Quartz F (225)

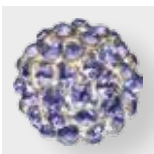

Tanzanite F (539)



Vintage Rose F (319)



Crystal Aurore Boreale F (001 AB)



Crystal Golden Shadow F (001 GSHA)

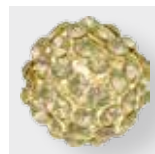

Crystal Luminous Green F (001 LUMG)



Crystal Silver Night (001 SINI)

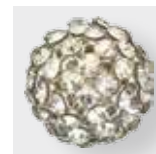

Crystal Silver Shade F (001 SSHA)

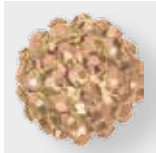

Crystal Rose Gold F
(001 ROGL)



Jet Hematite
(280 HEM)

AVAILABLE CRYSTAL MESH BALL MULTICOLORS

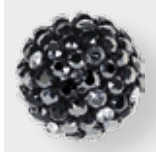

Black Multi (BKMU)

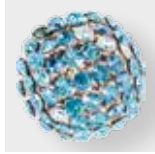

Blue Multi (BLMU)

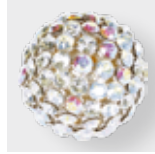

Crystal Multi (CRMU)

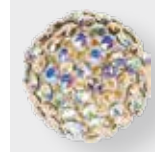

Light Silk Multi
(LSMU)

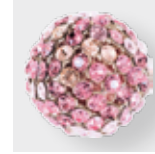

Light Rose Multi
(LRMU)

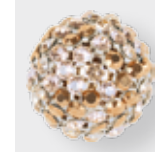

Silk Multi (SIMU)

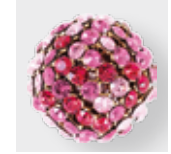

Rose Multi (ROMU)

AVAILABLE CRYSTAL MESH BALL DEGRADÉES



Black Degradée
(BKDE)

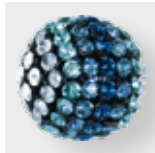

Blue Degradée (BLDE)



Silk Degradée (SIDE)

Beads

Crystal Mesh Ball

40 512 Crystal Mesh Ball

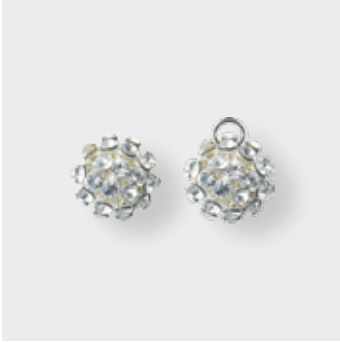

S	12 mm	
M	12 PCS	100%

40 515 Crystal Mesh Ball

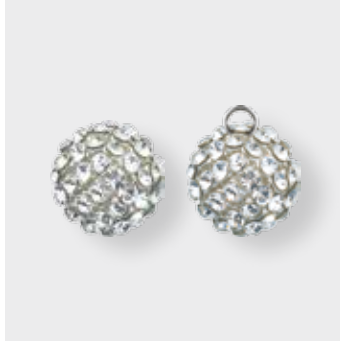

S	15 mm	
M	12 PCS	100%

40 519 Crystal Mesh Ball



S	19 mm	
M	6 PCS	100%

<p>40 512 40 515 40 519</p>	<p>Ring Configuration</p> <p>0 no jump ring*</p> <p>1 with 1 jump ring**</p>	<p>Sizes</p> <p>40 512 12 mm</p> <p>40 515 15 mm</p> <p>40 519 19 mm</p>				
<p>Crystal Combination</p> <ul style="list-style-type: none"> Crystal F (001) Crystal White Pearl (001 650) Casing Color: 082 Silver 						
<p>Color Combinations</p>						
<p>Plain Colors</p> <ul style="list-style-type: none"> Aquamarine F (202) Crystal Light Blue Pearl (001 302) Casing Color: 082 Silver Denim Blue F (266) Crystal Night Blue Pearl (001 818) Casing Color: 082 Silver Jet (280) Crystal Mystic Black Pearl (001 335) Casing Color: 012 Black Peridot F (214) Crystal Light Green Pearl (001 293) Casing Color: 082 Silver Rose F (209) Crystal Powder Rose Pearl (001 352) Casing Color: 082 Silver Smoky Quartz F (225) Crystal Deep Brown Pearl (001 414) Casing Color: 082 Silver Tanzanite F (539) Crystal Mauve Pearl (001 160) Casing Color: 082 Silver Vintage Rose F (319) Crystal Rosaline Pearl (001 294) Casing Color: 082 Silver 						

* The used thread enables a comfortable identification of the hole position and is not meant to be used for further application.

**The color of the jump ring is preestablished and can be seen in the article number. On special request the Crystal Mesh Ball can also be supplied with 2 jump rings.

		Ring Configuration		Sizes		
		0 no jump ring*	1 with 1 jump ring**	40 512 12 mm	40 515 15 mm	40 519 19 mm
<p>40 512 40 515 40 519</p>						
Crystal Effect Combinations						
Transparent Effects						
<p>Crystal AB F (001 AB) Crystal White Pearl (001 650) Casing Color: 082 Silver</p>		■	■	■	■	■
<p>Crystal Golden Shadow F (001 GSHA) Crystal Vintage Gold Pearl (001 651) Casing Color: 082 Silver</p>		■	■	■	■	■
<p>Crystal Luminous Green F (001 LUMG) Crystal Gold Pearl (001 296) Casing Color: 081 Gold</p>		■	■	■	■	■
<p>Crystal Silver Night F (001 SINI) Crystal Dark Grey Pearl (001 617) Casing Color: 082 Silver</p>		■	■	■	■	■
<p>Crystal Silver Shade F (001 SSHA) Crystal Platinum Pearl (001 459) Casing Color: 082 Silver</p>		■	■	■	■	■
Metallic Effects						
<p>Crystal Rose Gold F (001 ROGL) Crystal Rose Gold Pearl (001 769) Casing Color: 081 Gold</p>		■	■	■	■	■
Color Effect Combinations						
Metallic Effects						
<p>Jet Hematite (280 HEM) Crystal Black Pearl (001 298) Casing Color: 012 Black</p>		■	■	■	■	■

* The used thread enables a comfortable identification of the hole position and is not meant to be used for further application.

**The color of the jump ring is preestablished and can be seen in the article number. On special request the Crystal Mesh Ball can also be supplied with 2 jump rings.

40 512 40 515 40 519		Ring Configuration	0 no jump ring*	1 with 1 jump ring**	Sizes	40 512 12 mm	40 515 15 mm	40 519 19 mm
Multicolors								
<ul style="list-style-type: none"> Black Multi (BKMU)¹ Crystal Black Pearl (001 298) Casing Color: 012 Black 								
<ul style="list-style-type: none"> Blue Multi (BLMU)² Crystal Light Grey Pearl (001 616) Casing Color: 082 Silver 								
<ul style="list-style-type: none"> Crystal Multi (CRMU)³ Crystal Cream Pearl (001 620) Casing Color: 082 Silver 								
<ul style="list-style-type: none"> Light Silk Multi (LSMU)⁴ Crystal Gold Pearl (001 296) Casing Color: 082 Silver 								
<ul style="list-style-type: none"> Light Rose Multi (LRMU)⁵ Crystal Powder Rose Pearl (001 352) Casing Color: 082 Silver 								
<ul style="list-style-type: none"> Silk Multi (SIMU)⁶ Crystal Rose Gold Pearl (001 769) Casing Color: 082 Silver 								
<ul style="list-style-type: none"> Rose Multi (ROMU)⁷ Crystal Powder Rose Pearl (001 352) Casing Color: 081 Gold 								
Degradées								
<ul style="list-style-type: none"> Black Degradée (BKDE)⁸ Crystal Black Pearl (001 298) Casing Color: 012 Black 								
<ul style="list-style-type: none"> Blue Degradée (BLDE)⁹ Crystal Night Blue Pearl (001 818) Casing Color: 012 Black 								
<ul style="list-style-type: none"> Silk Degradée (SIDE)¹⁰ Crystal Peach Pearl (001 300) Casing Color: 082 Silver 								

* The used thread enables a comfortable identification of the hole position and is not meant to be used for further application.

** The color of the jump ring is preestablished and can be seen in the article number. On special request the Crystal Mesh Ball can also be supplied with 2 jump rings.

¹ Black Multi consists of Jet, Jet Hematite, Crystal Silver Night F.

² Blue Multi consists of Aquamarine F, Light Turquoise F, Crystal Blue Shade F.

³ Crystal Multi consists of Crystal F, Crystal Moonlight F, Crystal AB.

⁴ Light Silk Multi consists of Crystal AB F, Crystal Luminous Green F, Crystal Golden Shadow F.

⁵ Light Rose Multi consists of Crystal Antique Pink F, Light Rose F, Vintage Rose F.

⁶ Silk Multi consists of Silk F, Crystal Rose Gold, Light Silk F.

⁷ Rose Multi consists of Light Rose F, Rose F, Indian Pink F.

⁸ Black Degradée consists of Crystal, Crystal Silver Shade, Greige, Black Diamond, Crystal Silver Night.

⁹ Blue Degradée consists of Crystal, Crystal Blue Shade, Indian Sapphire, Denim Blue, Montana.

¹⁰ Silk Degradée consists of Crystal, Light Silk, Silk, Light Peach, Vintage Rose.

COMPLEMENTARY PRODUCTS

These protective plastic spacer rings are recommended for the use in between Beads, as they facilitate the longevity of the designs and enable the utilisation of larger sized Beads and complex cuts. Please order art. 7800 Nr. 646 with Sys.no. 977980 (packing unit = 100 pcs) and art. 7800 Nr. 647 with Sys.no. 977981 (packing unit = 1,000 pcs).

7800 Protective Spacer Rings

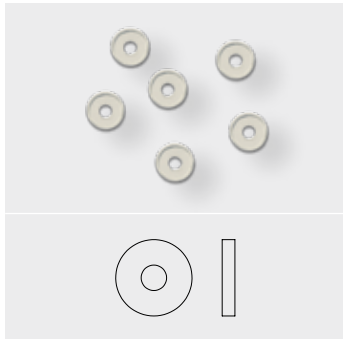

C	Transparent	
S	3 mm (hole 1 mm)	
M	100 PCS (Nr. 646)	
	1,000 PCS (Nr. 647)	150%

Beads

04 Beads

PRODUCT DETAILS

Article Size	Packing Unit = Minimum Order Quantity in Pieces	Average Net Weight in Gram per Packing Unit Crystal (001)	Average Gross Weight in Gram per Packing Unit Crystal (001)
5000			
2 mm	1,440	11.5	20.8
3 mm	720	23.6	33.4
4 mm	720	53.5	62.6
5 mm	720	105.3	116.3
6 mm	360	81.6	92.5
7 mm	288	126.2	159.2
8 mm	288	193.5	200.8
10 mm	144	180.6	199.4
12 mm	72	144.2	166.1
14 mm	72	247.1	280.5
16 mm	48	252.3	296.6
18 mm	24	168.7	185.9
20 mm	12	123.5	142.9
5003			
6 mm	360	109.9	120.8
8 mm	144	100.4	118.6
10 mm	144	195.9	219.2
12 mm	72	158.5	179.2
14 mm	48	172.4	193.0
5005			
8 mm	216	145.4	172.1
12 mm	72	154.3	175.4
16 mm	24	122.1	146.7
5020			
6 mm	360	74.5	85.2
8 mm	288	146.6	178.2
10 mm	144	116.4	139.2
5026			
6 mm	288	71.905	81.052
8 mm	144	72.576	98.340
10 mm	96	99.348	120.476
5028/4			
6 mm	360	75.791	83.435
8 mm	144	74.714	85.634
10 mm	72	70.763	76.467
5040			
4 mm	720	41.3	50.4
6 mm	360	71.8	82.9
8 mm	288	135.6	163.7
12 mm	144	214.4	242.4
18 mm	24	121.4	140.2
5041			
18 mm	24	114.2	133.0
5050			
14x10 mm	72	66.29	86.67
22x16 mm	36	90.40	115.60
5051			
8x6 mm	288	67.249	76.379
10x8 mm	144	50.803	74.903
5052			
6 mm	288	49.728	48.859
8 mm	144	42.336	65.831

Beads

Article Size	Packing Unit = Minimum Order Quantity in Pieces	Average Net Weight in Gram per Packing Unit Crystal (001)	Average Gross Weight in Gram per Packing Unit Crystal (001)
5053			
6 mm	288	49.728	58.859
8 mm	144	54.432	71.820
5054			
6 mm	288	39.997	49.145
8 mm	144	43.344	64.428
5055			
8x6 mm	144	39.476	60.476
10x8 mm	72	32.844	49.661
5056			
10x6 mm	144	41.731	62.731
12x8 mm	96	45.965	67.049
5139			
12.5 mm	48	44.6	61.8
5181			
13x7 mm	144	72.3	94.6
17x9 mm	48	52.2	72.2
5200			
6x4 mm	360	44.1	53.2
7.5x5 mm	360	80.0	91.0
5203			
12x8 mm	144	82.7	106.2
5305			
5 mm	720	52.7	63.9
6 mm	360	50.5	61.4
5308			
6 mm	360	54.4	65.4
5328			
2.5 mm	1,440	23.8	31.4
3 mm	1,440	34.1	45.2
4 mm	1,440	81.8	89.2
5 mm	720	89.3	100.0
6 mm	360	73.7	84.6
8 mm	288	141.8	173.4
10 mm	144	140.4	154.0
5500			
9x6 mm	144	59.0	69.9
10.5x7 mm	144	88.8	109.6
12x8 mm	144	144.0	164.1
5520			
12 mm	144	154.4	178.9
5523			
12 mm	144	143.2	173.6
16 mm	72	156.1	194.7
5535			
19x5 mm	72	60.26	85.54
23.5x5 mm	48	54.48	79.29
5540			
12 mm	72	62.1	86.7
17 mm	48	108.9	133.5

Beads

Article Size	Packing Unit = Minimum Order Quantity in Pieces	Average Net Weight in Gram per Packing Unit Crystal (001)	Average Gross Weight in Gram per Packing Unit Crystal (001)
5541			
11 mm	96	105.638	129.266
15 mm	48	126.202	146.241
5542			
8 mm	96	81.446	102.897
11 mm	48	97.574	118.581
5601			
4 mm	288	43.9	65.2
6 mm	144	70.6	88.9
8 mm	96	100.2	118.4
10 mm	72	138.0	156.5
12 mm	36	129.6	147.7
5603			
8 mm	144	119.3	138.6
10 mm	96	179.1	205.9
5621			
14 mm	96	168.7	202.1
18 mm	72	253.1	283.8
5624			
10 mm	108	117.51	134.15
14 mm	72	174.77	204.50
5625			
10 mm	108	108.86	127.0
5650			
12x8 mm	144	108.1	131.9
16x10 mm	72	138.0	153.9
5714			
8 mm	288	73.3	102.1
12 mm	108	72.3	102.2
5727			
14 mm	108	72.3	105.4
5742			
8 mm	288	120.5	154.5
10 mm	288	233.1	266.5
5743			
12 mm	108	72.23	96.96
17 mm	72	122.58	134.82
5744			
6 mm	360	47.4	58.1
8 mm	288	80.2	112.3
5747			
12x6 mm	144	64.35	81.17
16x8 mm	96	104.75	124.44
5750			
13 mm	12	24.192	43.798
19 mm	12	73.715	99.990
5752			
8 mm	288	106.06	136.88
12 mm	96	117.74	137.49

Beads

Article Size	Packing Unit = Minimum Order Quantity in Pieces	Average Net Weight in Gram per Packing Unit Crystal (001)	Average Gross Weight in Gram per Packing Unit Crystal (001)
5754			
6 mm	360	42.3	53.0
8 mm	288	77.9	109.8
10 mm	288	156.9	188.9
12 mm	144	136.7	168.9
5900			
14 mm	48	137.28	146.98
5942			
14 mm	48	103.25	130.56
40 512			
12 mm	12	25.4	42.8
40 515			
15 mm	12	45.4	61.6
40 519			
19 mm	6	45.1	62.2
7800			
Nr. 646	100	-	-
Nr. 647	1,000	-	-

BeCharmed & Pavé

The BeCharmed assortment, from Beads, Crystal Pearls, Pavé, and Rondelles to Stoppers and Pavé Balls in a brilliant array of colors and effects, offers unlimited combination possibilities. All products of this unique line feature a high-quality stainless steel part with Swarovski branding and a 4.5 mm-diameter hole, which is the standard size for existing charm concepts, making BeCharmed pieces ideal collectibles. Use them to create a look that is unique to you and commemorate life's unforgettable moments.

SUMMARY

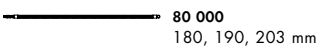
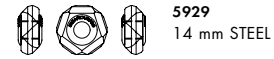
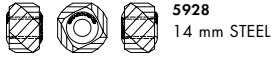
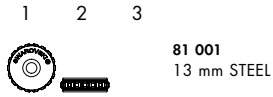
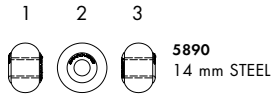

BeCharmed & Pavé

5890 Crystal BeCharmed Pearl

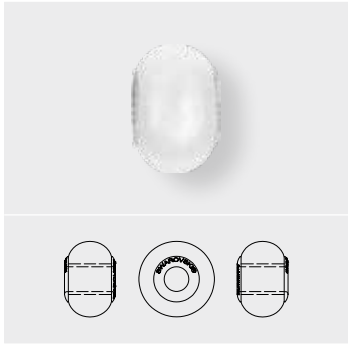

Size

14 mm STEEL

Colors

-  Crystal Black Pearl (001 298)
-  Crystal Blackberry Pearl (001 784)
-  Crystal Bronze Pearl (001 295)
-  Crystal Brown Pearl (001 815)
-  Crystal Burgundy Pearl (001 301)
-  Crystal Cream Pearl (001 620)
-  Crystal Creamrose Pearl (001 621)
-  Crystal Gold Pearl (001 296)
-  Crystal Grey Pearl (001 731)
-  Crystal Iridescent Green Pearl (001 930)
-  Crystal Lavender Pearl (001 524)
-  Crystal Light Grey Pearl (001 616)
-  Crystal Petrol Pearl (001 600)
-  Crystal Platinum Pearl (001 459)
-  Crystal Rosaline Pearl (001 294)
-  Crystal Rose Gold Pearl (001 769)
-  Crystal Rose Peach Pearl (001 674)
-  Crystal Tahitian-look Pearl (001 297)
-  Crystal Vintage Gold Pearl (001 651)
-  Crystal White Pearl (001 650)

Gemcolors

-  Crystal Coral Pearl (001 816)
-  Crystal Dark Lapis Pearl (001 719)
-  Crystal Ivory Pearl (001 708)
-  Crystal Jade Pearl (001 715)
-  Crystal Lapis Pearl (001 717)
-  Crystal Mystic Black Pearl (001 335)
-  Crystal Pink Coral Pearl (001 716)
-  Crystal Red Coral Pearl (001 718)
-  Crystal Turquoise Pearl (001 709)

Neoncolors

-  Crystal Neon Green Pearl (001 771)
-  Crystal Neon Orange Pearl (001 733)
-  Crystal Neon Pink Pearl (001 732)
-  Crystal Neon Red Pearl (001 770)
-  Crystal Neon Yellow Pearl (001 734)

5928 BeCharmed Helix Bead

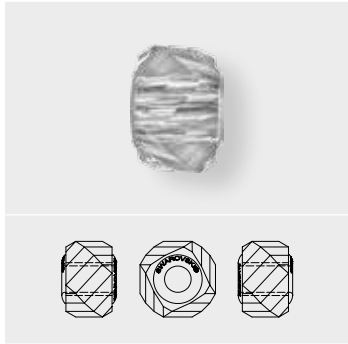

Size
14 mm STEEL

Crystal

Crystal (001)

Colors

Plain Colors

Amethyst (204)

Aquamarine (202)

Chrysolite (238)

Dark Moss Green (260)

Denim Blue (266)

Emerald (205)

Fern Green (291)

Fuchsia (502)

Indian Sapphire (217)

Indicolite (379)

Jet (280)

Jonquil (213)

Light Amethyst (212)

Light Rose (223)

Light Sapphire (211)

Light Smoked Topaz (221)

Light Topaz (226)

Mocca (286)

Montana (207)

Olivine (228)

Peridot (214)

Rosaline (508)

Rose (209)

Sapphire (206)

Smoked Topaz (220)

Topaz (203)

Violet (371)

Opal Colors

White Opal (234)

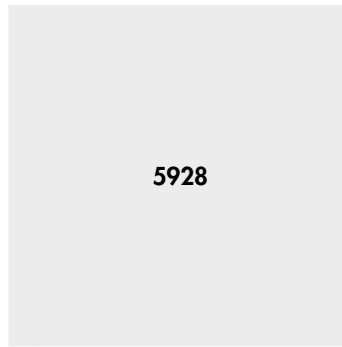

5928

Size
14 mm STEEL

Crystal Effects

Transparent Effects

Crystal AB (001 AB)

Crystal Astral Pink (001 API)

Crystal Blue Shade (001 BLSH)

Crystal Bronze Shade (001 BRSH)

Crystal Copper (001 COP)

Crystal Golden Shadow (001 GSHA)

Crystal Lilac Shadow (001 LISH)

Crystal Red Magma (001 REDM)

Crystal Satin (001 SAT)

Crystal Silver Shade (001 SSHA)

Metallic Effects

Crystal Iridescent Green (001 IRIG)

BeCharmed & Pavé

5929 BeCharmed Fortune Bead

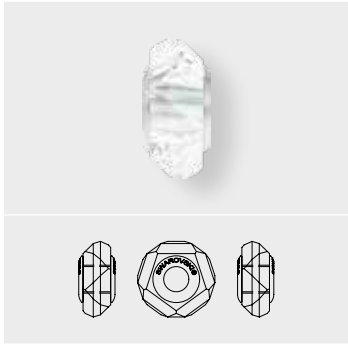

Size

14 mm STEEL

Crystal

Crystal (001)

Colors

Plain Colors

Amethyst (204)

Aquamarine (202)

Dark Moss Green (260)

Denim Blue (266)

Fuchsia (502)

Jet (280)

Light Rose (223)

Light Smoked Topaz (221)

Light Turquoise (263)

Peridot (214)

Rose (209)

Crystal Effects

Transparent Effects

Crystal AB (001 AB)

Crystal Astral Pink (001 API)

Crystal Blue Shade (001 BLSH)

Crystal Bronze Shade (001 BRSH)

Crystal Golden Shadow (001 GSHA)

Crystal Lilac Shadow (001 LISH)

Crystal Satin (001 SAT)

Crystal Silver Shade (001 SSHA)

Metallic Effects

Crystal Iridescent Green (001 IRIG)

BeCharmed & Pavé

5948 BeCharmed Briolette Bead



Size
14 mm STEEL

Crystal

Crystal (001)

Colors

Plain Colors

Amethyst (204)

Aquamarine (202)

Chrysolite (238)

Dark Moss Green (260)

Denim Blue (266)

Emerald (205)

Fern Green (291)

Fuchsia (502)

Indian Sapphire (217)

Indicolite (379)

Jet (280)

Jonquil (213)

Light Amethyst (212)

Light Rose (223)

Light Sapphire (211)

Light Smoked Topaz (221)

Light Topaz (226)

Mocca (286)

Montana (207)

Olivine (228)

Peridot (214)

Rosaline (508)

Rose (209)

Sapphire (206)

Smoked Topaz (220)

Topaz (203)

Violet (371)

Opal Colors

White Opal (234)



5948

Size
14 mm STEEL

Crystal Effects

Transparent Effects

Crystal AB (001 AB)

Crystal Astral Pink (001 API)

Crystal Blue Shade (001 BLSH)

Crystal Bronze Shade (001 BRSH)

Crystal Copper (001 COP)

Crystal Golden Shadow (001 GSHA)

Crystal Lilac Shadow (001 LISH)

Crystal Red Magma (001 REDM)

Crystal Satin (001 SAT)

Crystal Silver Shade (001 SSHA)

Metallic Effects

Crystal Iridescent Green (001 IRIG)

ARTICLE EXPLANATION

80 101 BeCharmed Pavé



S	14 mm	
M	12 PCS	100%

80 101	S	M	100 %
Article number	Size	Minimum order quantity in pieces (PCS)	Documentation size in %

EXPLANATION „COLOR COMBINATIONS“

All mentioned color combinations are preestablished in terms of

- Color of crystal
 - Color of Ceralun™
- and are not modifiable.

For ordering BeCharmed Pavé please follow the ordering example systematic below.

ORDERING EXAMPLE & PRODUCT VARIETY EXPLANATION

1	80 101	01	001
Metal Core	Article number	Color of Ceralun™	Color of crystal
1 Stainless Steel		Please see the respective product matrix for all available code reference	Please see the respective product matrix for all available code reference

BeCharmed & Pavé

80 101 BeCharmed Pavé

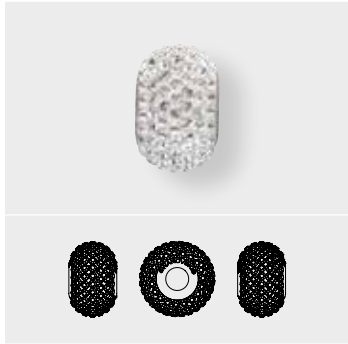

14 mm Stainless Steel

Crystal

- Crystal (001)
- White (01)

Colors

Plain Colors

- Amethyst (204)
- Dark Lila (09)
- Aquamarine (202)
- Light Blue (11)
- Black Diamond (215)
- Silver (03)
- Dark Moss Green (260)
- Shining Green (31)
- Emerald (205)
- Dark Green (13)
- Indian Siam (327)
- Shining Red (07)
- Jet (280)
- Black (02)
- Jonquil (213)
- Gold (04)
- Light Amethyst (212)
- Mauve (14)
- Light Rose (223)
- Rose (06)
- Light Sapphire (211)
- Sky Blue (18)
- Montana (207)
- Navy Blue (17)
- Peridot (214)
- Light Green (10)
- Rose (209)
- Rose (06)
- Sapphire (206)
- Dark Blue (15)
- Siam (208)
- Dark Red (16)
- Smoked Topaz (220)
- Umber (30)
- Tanzanite (539)
- Purple (08)
- Topaz (203)
- Shining Curry (12)

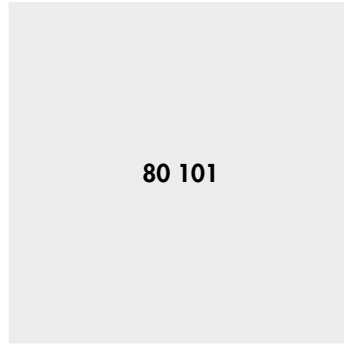

80 101

14 mm Stainless Steel

Crystal Effects

Transparent Effects

- Crystal AB (001 AB)
- White (01)
- Crystal Astral Pink (001 API)
- Shining Curry (12)
- Crystal Golden Shadow (001 GSHA)
- Pearl Silk (05)
- Crystal Lilac Shadow (001 LISH)
- Burgundy (29)
- Crystal Luminous Green (001 LUMG)
- Pearl Silk (05)
- Crystal Silver Night (001 SINI)
- Black (02)

Color Effects

Metallic Effects

- Jet Hematite (280 HEM)
- Black (02)

BeCharmed & Pavé

80 201 BeCharmed Pavé

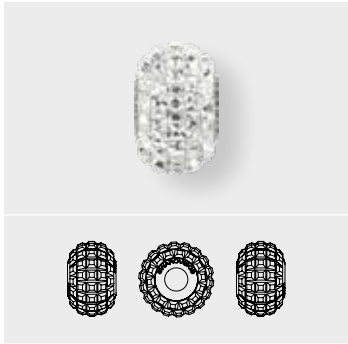

15 mm Stainless Steel

Crystal

- Crystal (001)
- White (01)

Colors

Plain Colors

- Amethyst (204)
- Dark Lila (09)
- Aquamarine (202)
- Light Blue (11)
- Black Diamond (215)
- Silver (03)
- Dark Moss Green (260)
- Shining Green (31)
- Emerald (205)
- Dark Green (13)
- Jet (280)
- Black (02)
- Light Amethyst (212)
- Mauve (14)
- Light Rose (223)
- Rose (06)
- Light Sapphire (211)
- Sky Blue (18)
- Light Siam (227)
- Shining Red (07)
- Montana (207)
- Navy Blue (17)
- Peridot (214)
- Light Green (10)
- Rose (209)
- Rose (06)
- Sapphire (206)
- Dark Blue (15)
- Siam (208)
- Dark Red (16)
- Smoked Topaz (220)
- Umber (30)
- Tanzanite (539)
- Purple (08)
- Topaz (203)
- Shining Curry (12)



80 201

15 mm Stainless Steel

Crystal Effects

Transparent Effects

- Crystal AB (001 AB)
- White (01)
- Crystal Golden Shadow (001 GSHA)
- Pearl Silk (05)
- Crystal Lilac Shadow (001 LISH)
- Burgundy (29)
- Crystal Luminous Green (001 LUMG)
- Pearl Silk (05)
- Crystal Silver Night (001 SINI)
- Black (02)

Color Effects

Metallic Effects

- Jet Hematite (280 HEM)
- Black (02)

BeCharmed & Pavé

80 301 BeCharmed Pavé



10.5 mm Stainless Steel

Crystal

- Crystal (001)
- White (01)

Colors

Plain Colors

- Amethyst (204)
- Dark Lila (09)
- Aquamarine (202)
- Light Blue (11)
- Black Diamond (215)
- Silver (03)
- Emerald (205)
- Dark Green (13)
- Indian Siam (327)
- Shining Red (07)
- Jet (280)
- Black (02)
- Light Amethyst (212)
- Mauve (14)
- Light Rose (223)
- Rose (06)
- Light Sapphire (211)
- Sky Blue (18)
- Montana (207)
- Navy Blue (17)
- Peridot (214)
- Light Green (10)
- Rose (209)
- Rose (06)
- Sapphire (206)
- Dark Blue (15)
- Siam (208)
- Dark Red (16)
- Smoked Topaz (220)
- Umber (30)
- Tanzanite (539)
- Purple (08)
- Topaz (203)
- Shining Curry (12)

Crystal Effects

Transparent Effects

- Crystal AB (001 AB)
- White (01)
- Crystal Golden Shadow (001 GSHA)
- Pearl Silk (05)

80 401 BeCharmed Pavé Spikes

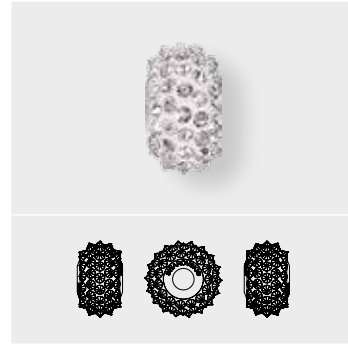

16 mm Stainless Steel

Colors

Plain Colors

- Jet (280)
- Black (02)

Crystal Effects

Transparent Effects

- Crystal AB (001 AB)
- White (01)
- Crystal Bermuda Blue (001 BBL)
- Dark Blue (15)
- Crystal Golden Shadow (001 GSHA)
- Pearl Silk (05)
- Crystal Red Magma (001 REDM)
- Red (21)
- Crystal Silver Shade (001 SSHA)
- Grey (19)
- Crystal Comet Argent Light V (001 CALV)
- Silver (03)
- Crystal Metallic Light Gold (001 MLGLD)
- Metallic Gold (20)

Metallic Effects

BeCharmed & Pavé

80 501 BeCharmed Pavé Cabochon



Size

15.5 mm Stainless Steel

Crystal

- Crystal (001)
- White (01)

Crystal Effects

Transparent Effects

- Crystal Matt Finish (001 MATTFI)
- White (01)
- Crystal AB (001 AB)
- White (01)
- Crystal AB Matt Finish (001 AB MATTFI)
- White (01)

- Crystal Antique Pink (001 ANTP)
- Antique Rose (22)

- Crystal Antique Pink Matt Finish (001 ANTP MATTFI)
- Antique Rose (22)

- Crystal Golden Shadow (001 GSHA)
- Pearl Silk (05)

- Crystal Golden Sh. Matt Finish (001 GSHA MATTFI)
- Pearl Silk (05)

Metallic Effects

- Crystal Chrom (001 CHRM)
- Grey (19)

- Crystal Chrom Matt Finish (001 CHRM MATTFI)
- Silver (03)

- Crystal Metallic Light Gold (001 MLGLD)
- Metallic Gold (20)

- Crystal Met. L. Gold Matt Finish (001 MLGLD MATTFI)
- Metallic Gold Matt (23)

Color Effects

Metallic Effects

- Jet Hematite (280 HEM)
- Black (02)

- Jet Hematite Matt Finish (280 HEM MATTFI)
- Black (02)

80 601 BeCharmed Pavé Cabochon



Size

10.5 mm Stainless Steel

Crystal

- Crystal (001)
- White (01)

Crystal Effects

Transparent Effects

- Crystal Matt Finish (001 MATTFI)
- White (01)
- Crystal AB (001 AB)
- White (01)
- Crystal AB Matt Finish (001 AB MATTFI)
- White (01)

- Crystal Antique Pink (001 ANTP)
- Antique Rose (22)

- Crystal Antique Pink Matt Finish (001 ANTP MATTFI)
- Antique Rose (22)

- Crystal Golden Shadow (001 GSHA)
- Pearl Silk (05)

- Crystal Golden Sh. Matt Finish (001 GSHA MATTFI)
- Pearl Silk (05)

Metallic Effects

- Crystal Chrom (001 CHRM)
- Grey (19)

- Crystal Chrom Matt Finish (001 CHRM MATTFI)
- Silver (03)

- Crystal Metallic Light Gold (001 MLGLD)
- Metallic Gold (20)

- Crystal Met. L. Gold Matt Finish (001 MLGLD MATTFI)
- Metallic Gold Matt (23)

Color Effects

Metallic Effects

- Jet Hematite (280 HEM)
- Black (02)

- Jet Hematite Matt Finish (280 HEM MATTFI)
- Black (02)





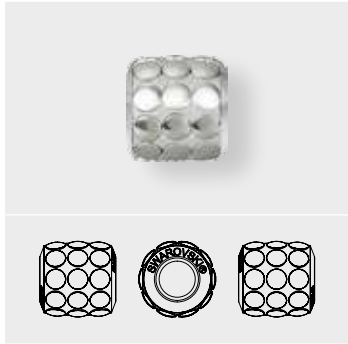



BeCharmed & Pavé

80 701 BeCharmed Pavé Metallics



Size
9.5 mm Stainless Steel

Colors





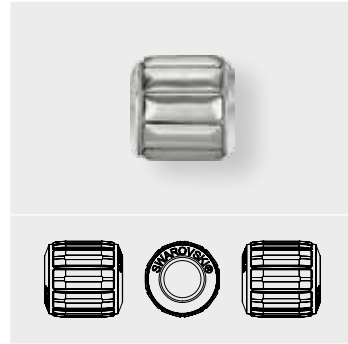





-  Black Polished
-  Black (02)
-  Blue Brushed
-  Luminous Blue (24)
-  Bronze Brushed
-  Bronze (28)
-  Bronze Polished
-  Bronze (28)
-  Copper Brushed
-  Copper (26)
-  Copper Polished
-  Copper (26)
-  Gold Brushed
-  Shining Gold (25)
-  Gold Polished
-  Shining Gold (25)
-  Gun Metal Brushed
-  Anthracite (27)
-  Gun Metal Polished
-  Anthracite (27)
-  Silver Brushed
-  Silver (03)
-  Silver Polished
-  Silver (03)

80 801 BeCharmed Pavé Metallics



Size
9.5 mm Stainless Steel

Colors

-  Black Polished
-  Black (02)
-  Blue Brushed
-  Luminous Blue (24)
-  Bronze Brushed
-  Bronze (28)
-  Bronze Polished
-  Bronze (28)
-  Copper Brushed
-  Copper (26)
-  Copper Polished
-  Copper (26)
-  Gold Brushed
-  Shining Gold (25)
-  Gold Polished
-  Shining Gold (25)
-  Gun Metal Brushed
-  Anthracite (27)
-  Gun Metal Polished
-  Anthracite (27)
-  Silver Brushed
-  Silver (03)
-  Silver Polished
-  Silver (03)

BeCharmed & Pavé

80 901 BeCharmed Pavé Spikes

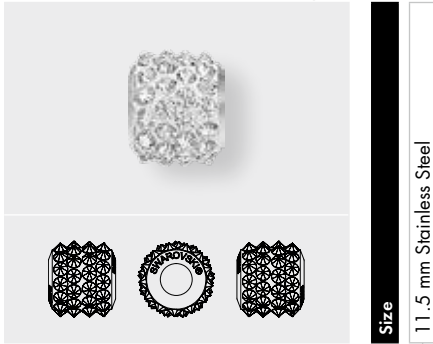

Color

Plain Color

- Jet (280)
- Black (02)

Crystal Effects

Transparent Effects

- Crystal AB (001 AB)
- White (01)
- Crystal Bermuda Blue (001 BBL)
- Dark Blue (15)
- Crystal Golden Shadow (001 GSHA)
- Pearl Silk (05)
- Crystal Red Magma (001 REDM)
- Red (21)
- Crystal Silver Shade (001 SSHA)
- Grey (19)

Metallic Effects

- Crystal Comet Argent Light V (001 CALV)
- Silver (03)
- Crystal Metallic Light Gold (001 MLGLD)
- Metallic Gold (20)

BeCharmed & Pavé

81 001 BeCharmed Pavé Stopper



Size
13 mm Stainless Steel

Crystal

- Crystal (001)
- White (01)

Colors

Plain Colors

- Amethyst (204)
- Dark Lila (09)
- Aquamarine (202)
- Light Blue (11)
- Black Diamond (215)
- Silver (03)
- Dark Moss Green (260)
- Shining Green (31)
- Emerald (205)
- Dark Green (13)
- Jet (280)
- Black (02)
- Light Amethyst (212)
- Mauve (14)
- Light Rose (223)
- Rose (06)
- Light Sapphire (211)
- Sky Blue (18)
- Light Siam (227)
- Shining Red (07)
- Montana (207)
- Navy Blue (17)
- Peridot (214)
- Light Green (10)
- Rose (209)
- Rose (06)
- Sapphire (206)
- Dark Blue (15)
- Siam (208)
- Dark Red (16)
- Smoked Topaz (220)
- Umber (30)
- Tanzanite (539)
- Purple (08)
- Topaz (203)
- Shining Curry (12)



Size
13 mm Stainless Steel

Crystal Effects

Transparent Effects

- Crystal AB (001 AB)
- White (01)
- Crystal Golden Shadow (001 GSHA)
- Pearl Silk (05)
- Crystal Lilac Shadow (001 LISH)
- Burgundy (29)
- Crystal Luminous Green (001 LUMG)
- Pearl Silk (05)
- Crystal Silver Night (001 SINI)
- Black (02)

Color Effects

Metallic Effects

- Jet Hematite (280 HEM)
- Black (02)

BeCharmed & Pavé

81 101 BeCharmed Pavé Slim

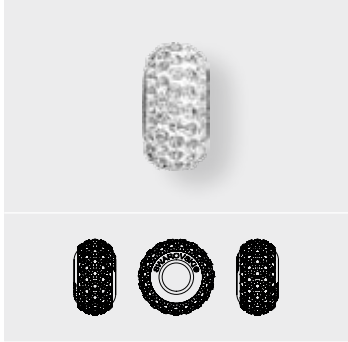

Size
13.5 mm Stainless Steel

Crystal

- Crystal (001)
- White (01)

Colors

Plain Colors

- Amethyst (204)
- Dark Lila (09)
- Aquamarine (202)
- Light Blue (11)
- Black Diamond (215)
- Silver (03)
- Dark Moss Green (260)
- Shining Green (31)
- Emerald (205)
- Dark Green (13)
- Indian Siam (327)
- Shining Red (07)
- Jet (280)
- Black (02)
- Jonquil (213)
- Gold (04)
- Light Amethyst (212)
- Mauve (14)
- Light Rose (223)
- Rose (06)
- Light Sapphire (211)
- Sky Blue (18)
- Montana (207)
- Navy Blue (17)
- Peridot (214)
- Light Green (10)
- Rose (209)
- Rose (06)
- Sapphire (206)
- Dark Blue (15)
- Siam (208)
- Dark Red (16)
- Smoked Topaz (220)
- Umber (30)
- Tanzanite (539)
- Purple (08)
- Topaz (203)
- Shining Curry (12)

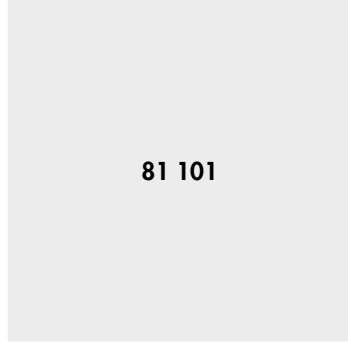

81 101

Size
13.5 mm Stainless Steel

Crystal Effects

Transparent Effects

- Crystal AB (001 AB)
- White (01)
- Crystal Astral Pink (001 API)
- Shining Curry (12)
- Crystal Golden Shadow (001 GSHA)
- Pearl Silk (05)
- Crystal Lilac Shadow (001 LISH)
- Burgundy (29)
- Crystal Luminous Green (001 LUMG)
- Pearl Silk (05)
- Crystal Silver Night (001 SINI)
- Black (02)

Color Effects

Metallic Effects

- Jet Hematite (280 HEM)
- Black (02)

81 201 BeCharmed Pavé Slim

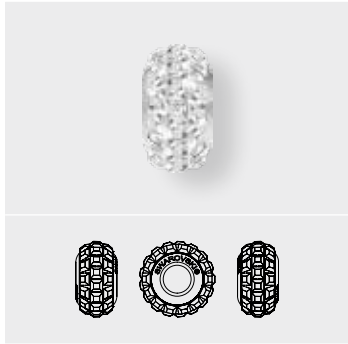

Size
13 mm Stainless Steel

Crystal

- Crystal (001)
- White (01)

Colors

Plain Colors

- Amethyst (204)
- Dark Lila (09)
- Aquamarine (202)
- Light Blue (11)
- Black Diamond (215)
- Silver (03)
- Dark Moss Green (260)
- Shining Green (31)
- Emerald (205)
- Dark Green (13)
- Jet (280)
- Black (02)
- Light Amethyst (212)
- Mauve (14)
- Light Rose (223)
- Rose (06)
- Light Sapphire (211)
- Sky Blue (18)
- Light Siam (227)
- Shining Red (07)
- Montana (207)
- Navy Blue (17)
- Peridot (214)
- Light Green (10)
- Rose (209)
- Rose (06)
- Sapphire (206)
- Dark Blue (15)
- Siam (208)
- Shining Red (07)
- Smoked Topaz (220)
- Umber (30)
- Tanzanite (539)
- Purple (08)
- Topaz (203)
- Shining Curry (12)



Size
13 mm Stainless Steel

Crystal Effects

Transparent Effects

- Crystal AB (001 AB)
- White (01)
- Crystal Golden Shadow (001 GSHA)
- Pearl Silk (05)
- Crystal Lilac Shadow (001 LISH)
- Burgundy (29)
- Crystal Luminous Green (001 LUMG)
- Pearl Silk (05)
- Crystal Silver Night (001 SINI)
- Black (02)

Color Effects

Metallic Effects

- Jet Hematite (280 HEM)
- Black (02)

BeCharmed & Pavé

77 510 & 77 512 BeCharmed Rondelle



Size

10 mm (PP 24)

12 mm (PP 32)

Crystal

Crystal F (001)

Colors

Plain Colors

Amethyst F (204)

Aquamarine F (202)

Black Diamond F (215)

Dark Moss Green F (260)

Emerald F (205)

Jet (280)

Jonquil F (213)

Light Amethyst F (212)

Light Colorado Topaz F (246)

Light Rose F (223)

Light Sapphire F (211)

Light Siam F (227)

Montana F (207)

Peridot F (214)

Rose F (209)

Sapphire F (206)

Siam F (208)

Smoked Topaz F (220)

Tanzanite F (539)

Topaz F (203)

Crystal Effects

Transparent Effects

Crystal AB F (001 AB)

Crystal Golden Shadow F (001 GSHA)

Crystal Lilac Shadow F (001 LISH)

Crystal Silver Shade F (001 SSHA)

ARTICLE EXPLANATION

80 000 BeCharmed Bracelet



S	180 mm	
M	6 PCS	66%

80 000	S	M	66%
Article number	Size	Minimum order quantity in pieces (PCS)	Documentation size in %

ORDERING EXAMPLE & PRODUCT VARIETY EXPLANATION

1	80 000	180 mm	H
Metal Type	Article number	Size	Plating color
1 Brass		Size of Bracelet (Length)	H Rhodium Plating*

80 000 BeCharmed Bracelet

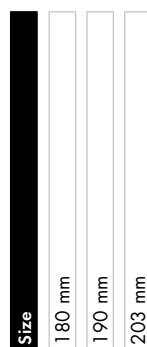

Color of Casing
H Rhodium Plating*

* Anti nickel allergenic

ARTICLE EXPLANATION

86 001 Pavé Ball



S	8 mm	
M	12 PCS	100%

86 001	S	M	100 %
Article number	Size	Minimum order quantity in pieces (PCS)	Documentation size in %

EXPLANATION OF "COLOR COMBINATIONS"

All mentioned color combinations are pre-established in terms of

- Color of crystal
 - Color of Ceralun™
- and are not modifiable.

ORDERING EXAMPLE & PRODUCT VARIETY EXPLANATION

86 001	10 mm	01	001
Article number	Size	Color of Ceralun™	Color of crystal
	4 mm	Please see the respective product matrix for all available code references.	Please see the respective product matrix for all available code references.
	6 mm		
	8 mm		
	10 mm		

AVAILABLE PAVÉ BALLS

86 001

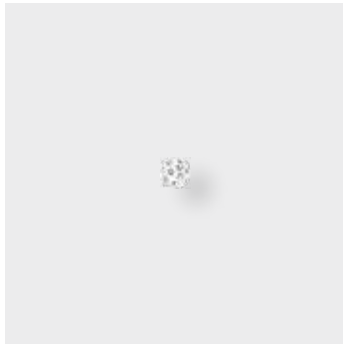

S	4 mm
M	12 PCS
	100%

86 001



S	6 mm
M	12 PCS
	100%

86 001



S	8 mm
M	12 PCS
	100%

86 001

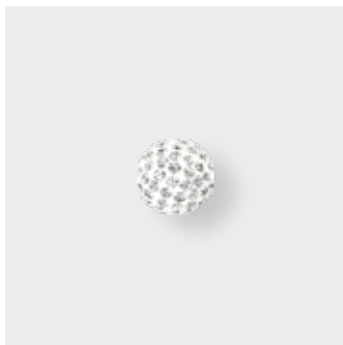

S	10 mm
M	12 PCS
	100%

86 001 Pavé Ball

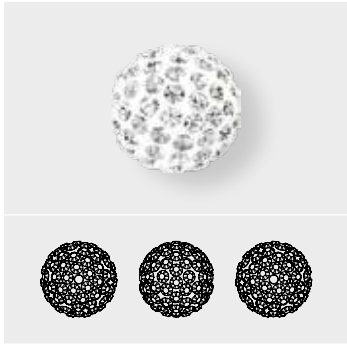

Size	4 mm	6 mm	8 mm	10 mm
------	------	------	------	-------

Crystal

- Crystal (001)
- White (01)

Colors

Plain Colors

- Amethyst (204)
- Dark Lila (09)
- Aquamarine (202)
- Light Blue (11)
- Black Diamond (215)
- Silver (03)
- Dark Moss Green (260)
- Shining Green (31)
- Emerald (205)
- Dark Green (13)
- Indian Siam (327)
- Shining Red (07)
- Jet (280)
- Black (02)
- Jonquil (213)
- Gold (04)
- Light Amethyst (212)
- Mauve (14)
- Light Rose (223)
- Rose (06)
- Light Sapphire (211)
- Sky Blue (18)
- Montana (207)
- Navy Blue (17)
- Peridot (214)
- Light Green (10)
- Rose (209)
- Rose (06)
- Sapphire (206)
- Dark Blue (15)
- Siam (208)
- Dark Red (16)
- Smoked Topaz (220)
- Umber (30)
- Tanzanite (539)
- Purple (08)
- Topaz (203)
- Shining Curry (12)

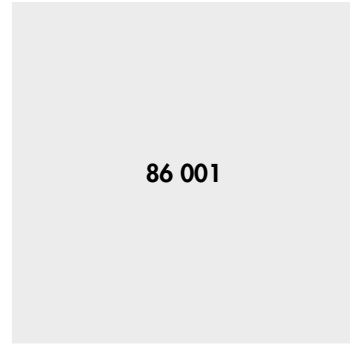

Size	4 mm	6 mm	8 mm	10 mm
------	------	------	------	-------

Crystal Effects

Transparent Effects

- Crystal AB (001 AB)
- White (01)
- Crystal Golden Shadow (001 GSHA)
- Pearl Silk (05)

Color Effects

Metallic Effects

- Jet Hematite (280 HEM)
- Black (02)

PRODUCT DETAILS

Article Size	Packing Unit = Minimum Order Quantity in Pieces	Average Net Weight in Gram per Packing Unit Crystal (001)	Average Gross Weight in Gram per Packing Unit Crystal (001)
5890 14 mm STEEL	12	29.13	36.33
5928 14 mm STEEL	12	26.208	45.814
5929 14 mm STEEL	12	19.152	36.409
5948 14 mm STEEL	12	27.216	46.822
80 101 14 mm Stainless Steel	12	38.40	56.40
80 201 15 mm Stainless Steel	12	40.80	58.80
80 301 10.5 mm Stainless Steel	12	19.68	37.68
80 401 16 mm Stainless Steel	12	31.92	49.92
80 501 15.5 mm Stainless Steel	12	31.92	49.92
80 601 10.5 mm Stainless Steel	12	18.72	36.72
80 701 9.5 mm Stainless Steel	12	15.96	33.96
80 801 9.5 mm Stainless Steel	12	15.96	33.96
80 901 11.5 mm Stainless Steel	12	18.60	36.60
81 001 13 mm Stainless Steel	12	20.16	38.16
81 101 13.5 mm Stainless Steel	12	17.88	35.88
81 201 13 mm Stainless Steel	12	16.80	34.80
77 510 10 mm	144	63.36	66.56
77 512 12 mm	144	112.32	115.52
80 000 180 mm	6	37.80	41.28
190 mm	6	38.58	42.06
203 mm	6	39.54	43.02
86 001 4 mm	12	1.08	19.08
6 mm	12	3.48	21.48
8 mm	12	7.80	25.80
10 mm	12	14.52	32.52

Crystal Pearls

Crystal Pearls are perfect replicas of genuine pearls. They are made of a unique crystal core covered with an innovative pearl coating, which features a flawless, silky smooth, rounded surface. They are available in a variety of shapes, sizes, and colors and are delivered loosely threaded or, if desired, also knotted. Different hole diameters are available to accommodate a range of applications: art. 5811 Crystal Pearl (large hole), art. 5840 Crystal Baroque Pearl and art. 5860 Crystal Coin Pearl are perfectly suited to applications that require a larger hole diameter. Crystal Pearls offer unlimited combination possibilities with the colorful loose crystal elements assortment.

Crystal Pearls

Colors

-  **Crystal White Pearl**
001 650
-  **Crystal Light Creamrose Pearl**
001 618
-  **Crystal Cream Pearl**
001 620
-  **Crystal Creamrose Pearl**
001 621
-  **Crystal Light Gold Pearl**
001 539
-  **Crystal Gold Pearl**
001 296
-  **Crystal Vintage Gold Pearl**
001 651
-  **Crystal Bright Gold Pearl**
001 306
-  **Crystal Bronze Pearl**
001 295
-  **Crystal Rose Gold Pearl**
001 769
-  **Crystal Powder Almond Pearl**
001 305
-  **Crystal Peach Pearl**
001 300
-  **Crystal Rosaline Pearl**
001 294
-  **Crystal Rose Peach Pearl**
001 674
-  **Crystal Powder Rose Pearl**
001 352

-  **Crystal Mauve Pearl**
001 160
-  **Crystal Lavender Pearl**
001 524
-  **Crystal Burgundy Pearl**
001 301
-  **Crystal Blackberry Pearl**
001 784
-  **Crystal Bordeaux Pearl**
001 538
-  **Crystal Night Blue Pearl**
001 818
-  **Crystal Petrol Pearl**
001 600
-  **Crystal Tahitian-look Pearl**
001 297
-  **Crystal Iridescent Green Pearl**
001 930
-  **Crystal Light Blue Pearl**
001 302
-  **Crystal Light Grey Pearl**
001 616
-  **Crystal Platinum Pearl**
001 459
-  **Crystal Grey Pearl**
001 731
-  **Crystal Dark Grey Pearl**
001 617
-  **Crystal Black Pearl**
001 298
-  **Crystal Brown Pearl**
001 815

Gemcolors

-  **Crystal Ivory Pearl**
001 708
-  **Crystal Pink Coral Pearl**
001 716
-  **Crystal Coral Pearl**
001 816
-  **Crystal Red Coral Pearl**
001 718
-  **Crystal Turquoise Pearl**
001 709
-  **Crystal Lapis Pearl**
001 717
-  **Crystal Dark Lapis Pearl**
001 719
-  **Crystal Jade Pearl**
001 715
-  **Crystal Mystic Black Pearl**
001 335

Neoncolors

-  **Crystal Neon Yellow Pearl***
001 734
-  **Crystal Neon Orange Pearl***
001 733
-  **Crystal Neon Red Pearl***
001 770
-  **Crystal Neon Pink Pearl***
001 732
-  **Crystal Neon Green Pearl***
001 771

* Please note that due to print-technical limitations the color references of Crystal Pearls Neoncolors do not equal the true luminescent appearance of the real article.

Crystal Pearls

Numerical Order

001 160 Crystal Mauve Pearl
001 294 Crystal Rosaline Pearl
001 295 Crystal Bronze Pearl
001 296 Crystal Gold Pearl
001 297 Crystal Tahitian-look Pearl
001 298 Crystal Black Pearl
001 300 Crystal Peach Pearl
001 301 Crystal Burgundy Pearl
001 302 Crystal Light Blue Pearl
001 305 Crystal Powder Almond Pearl
001 306 Crystal Bright Gold Pearl
001 335 Crystal Mystic Black Pearl
001 352 Crystal Powder Rose Pearl
001 459 Crystal Platinum Pearl
001 524 Crystal Lavender Pearl
001 538 Crystal Bordeaux Pearl
001 539 Crystal Light Gold Pearl
001 600 Crystal Petrol Pearl
001 616 Crystal Light Grey Pearl
001 617 Crystal Dark Grey Pearl
001 618 Crystal Light Creamrose Pearl
001 620 Crystal Cream Pearl
001 621 Crystal Creamrose Pearl
001 650 Crystal White Pearl
001 651 Crystal Vintage Gold Pearl
001 674 Crystal Rose Peach Pearl
001 708 Crystal Ivory Pearl
001 709 Crystal Turquoise Pearl
001 715 Crystal Jade Pearl
001 716 Crystal Pink Coral Pearl
001 717 Crystal Lapis Pearl
001 718 Crystal Red Coral Pearl
001 719 Crystal Dark Lapis Pearl
001 731 Crystal Grey Pearl
001 732 Crystal Neon Pink Pearl
001 733 Crystal Neon Orange Pearl
001 734 Crystal Neon Yellow Pearl
001 769 Crystal Rose Gold Pearl
001 770 Crystal Neon Red Pearl
001 771 Crystal Neon Green Pearl
001 784 Crystal Blackberry Pearl
001 815 Crystal Brown Pearl
001 816 Crystal Coral Pearl
001 818 Crystal Night Blue Pearl
001 930 Crystal Iridescent Green Pearl

Alphabetical Order

Crystal Black Pearl (001 298)
Crystal Blackberry Pearl (001 784)
Crystal Bordeaux Pearl (001 538)
Crystal Bright Gold Pearl (001 306)
Crystal Bronze Pearl (001 295)
Crystal Brown Pearl (001 815)
Crystal Burgundy Pearl (001 301)
Crystal Coral Pearl (001 816)
Crystal Cream Pearl (001 620)
Crystal Creamrose Pearl (001 621)
Crystal Dark Grey Pearl (001 617)
Crystal Dark Lapis Pearl (001 719)
Crystal Gold Pearl (001 296)
Crystal Grey Pearl (001 731)
Crystal Iridescent Green Pearl (001 930)
Crystal Ivory Pearl (001 708)
Crystal Jade Pearl (001 715)
Crystal Lapis Pearl (001 717)
Crystal Lavender Pearl (001 524)
Crystal Light Blue Pearl (001 302)
Crystal Light Creamrose Pearl (001 618)
Crystal Light Gold Pearl (001 539)
Crystal Light Grey Pearl (001 616)
Crystal Mauve Pearl (001 160)
Crystal Mystic Black Pearl (001 335)
Crystal Neon Green Pearl (001 771)
Crystal Neon Orange Pearl (001 733)
Crystal Neon Pink Pearl (001 732)
Crystal Neon Red Pearl (001 770)
Crystal Neon Yellow Pearl (001 734)
Crystal Night Blue Pearl (001 818)
Crystal Peach Pearl (001 300)
Crystal Petrol Pearl (001 600)
Crystal Pink Coral Pearl (001 716)
Crystal Platinum Pearl (001 459)
Crystal Powder Almond Pearl (001 305)
Crystal Powder Rose Pearl (001 352)
Crystal Red Coral Pearl (001 718)
Crystal Rosaline Pearl (001 294)
Crystal Rose Gold Pearl (001 769)
Crystal Rose Peach Pearl (001 674)
Crystal Tahitian-look Pearl (001 297)
Crystal Turquoise Pearl (001 709)
Crystal Vintage Gold Pearl (001 651)
Crystal White Pearl (001 650)

Crystal Pearls

SUMMARY

1 2 3

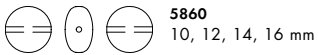
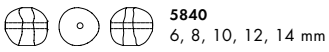
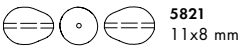
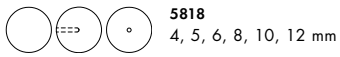
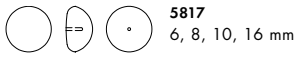
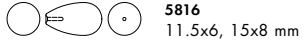
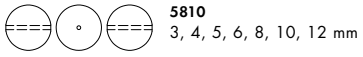

Crystal Pearls

ORDERING EXAMPLE & PRODUCT VARIETY EXPLANATION

5850

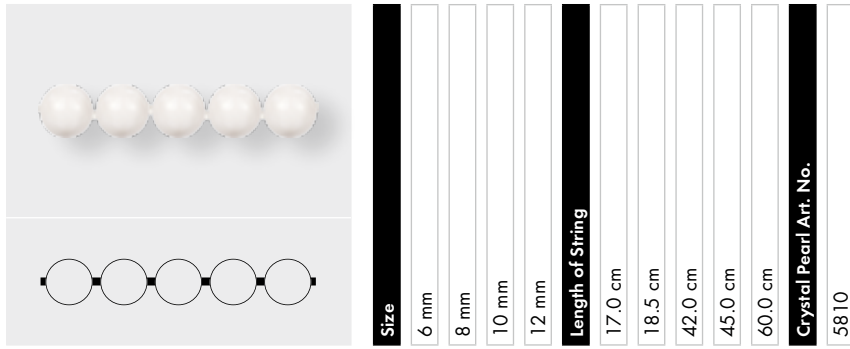

5850	8 mm	001 650	0170	ES
Article number	Crystal Pearl size	Color	Length	Ending solution
	All sizes are subject to special orders.	Desired Crystal Pearl color code Please see respective product matrix for all available code references.	Can deviate by +/- 0.5 cm; measured from the first to the last pearl on the string (excl. shell calotte) 0170 = 17.0 cm 0185 = 18.5 cm 0420 = 42.0 cm 0450 = 45.0 cm 0600 = 60.0 cm	EO: Last 3 pearls at ends are loosely threaded and not knotted (15 cm extra thread at each end) EG: Gold plated shell calotte ES: Silver plated shell calotte

As general guideline for customers, Crystal Pearls bigger than 6 mm should be knotted. If the pearls are not knotted, a wire (steel, French) etc. should be used.

Crystal Pearls

5810 Crystal Round Pearl

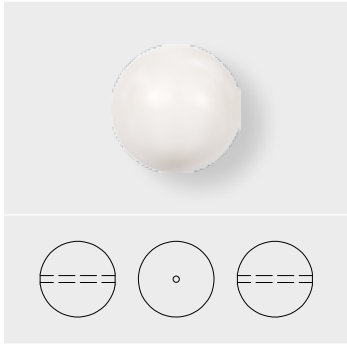















Size	3 mm	4 mm	5 mm	6 mm	8 mm	10 mm	12 mm
------	------	------	------	------	------	-------	-------

Colors

Crystal Black Pearl (001 298)	■	■	■	■	■	■	■
Crystal Blackberry Pearl (001 784)	■	■	■	■	■	■	■
Crystal Bordeaux Pearl (001 538)	■	■	■	■	■	■	■
Crystal Bright Gold Pearl (001 306)	■	■	■	■	■	■	■
Crystal Bronze Pearl (001 295)	■	■	■	■	■	■	■
Crystal Brown Pearl (001 815)	■	■	■	■	■	■	■
Crystal Burgundy Pearl (001 301)	■	■	■	■	■	■	■
Crystal Cream Pearl (001 620)	■	■	■	■	■	■	■
Crystal Creamrose Pearl (001 621)	■	■	■	■	■	■	■
Crystal Dark Grey Pearl (001 617)	■	■	■	■	■	■	■
Crystal Gold Pearl (001 296)	■	■	■	■	■	■	■
Crystal Grey Pearl (001 731)	■	■	■	■	■	■	■
Crystal Iridescent Green Pearl (001 930)	■	■	■	■	■	■	■
Crystal Lavender Pearl (001 524)	■	■	■	■	■	■	■
Crystal Light Blue Pearl (001 302)	■	■	■	■	■	■	■
Crystal Light Creamrose Pearl (001 618)	■	■	■	■	■	■	■
Crystal Light Gold Pearl (001 539)	■	■	■	■	■	■	■
Crystal Light Grey Pearl (001 616)	■	■	■	■	■	■	■
Crystal Mauve Pearl (001 160)	■	■	■	■	■	■	■
Crystal Night Blue Pearl (001 818)	■	■	■	■	■	■	■
Crystal Peach Pearl (001 300)	■	■	■	■	■	■	■
Crystal Petrol Pearl (001 600)	■	■	■	■	■	■	■
Crystal Platinum Pearl (001 459)	■	■	■	■	■	■	■
Crystal Powder Almond Pearl (001 305)	■	■	■	■	■	■	■
Crystal Powder Rose Pearl (001 352)	■	■	■	■	■	■	■
Crystal Rosaline Pearl (001 294)	■	■	■	■	■	■	■
Crystal Rose Gold Pearl (001 769)	■	■	■	■	■	■	■
Crystal Rose Peach Pearl (001 674)	■	■	■	■	■	■	■
Crystal Tahitian-look Pearl (001 297)	■	■	■	■	■	■	■
Crystal Vintage Gold Pearl (001 651)	■	■	■	■	■	■	■
Crystal White Pearl (001 650)	■	■	■	■	■	■	■

Crystal Pearls

5810		Size						
		3 mm	4 mm	5 mm	6 mm	8 mm	10 mm	12 mm
Gemcolors								
	Crystal Coral Pearl (001 816)	■	■	■	■	■	■	■
	Crystal Dark Lapis Pearl (001 719)	■	■	■	■	■	■	■
	Crystal Ivory Pearl (001 708)	■	■	■	■	■	■	■
	Crystal Jade Pearl (001 715)	■	■	■	■	■	■	■
	Crystal Lapis Pearl (001 717)	■	■	■	■	■	■	■
	Crystal Mystic Black Pearl (001 335)	■	■	■	■	■	■	■
	Crystal Pink Coral Pearl (001 716)	■	■	■	■	■	■	■
	Crystal Red Coral Pearl (001 718)	■	■	■	■	■	■	■
	Crystal Turquoise Pearl (001 709)	■	■	■	■	■	■	■
Neoncolors								
	Crystal Neon Green Pearl (001 771)	■	■	■	■	■	■	■
	Crystal Neon Orange Pearl (001 733)	■	■	■	■	■	■	■
	Crystal Neon Pink Pearl (001 732)	■	■	■	■	■	■	■
	Crystal Neon Red Pearl (001 770)	■	■	■	■	■	■	■
	Crystal Neon Yellow Pearl (001 734)	■	■	■	■	■	■	■

Crystal Pearls

5811 Crystal Pearl (large hole)

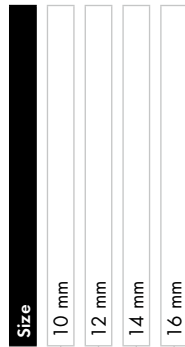
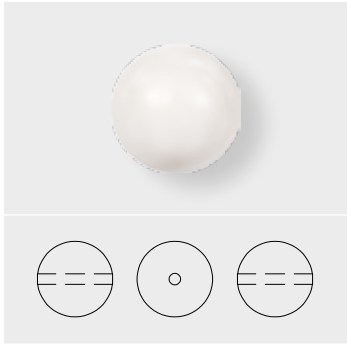

Colors

	Crystal Black Pearl (001 298)	■	■	■	■
	Crystal Blackberry Pearl (001 784)	■	■	■	■
	Crystal Bordeaux Pearl (001 538)	■	■	■	■
	Crystal Bright Gold Pearl (001 306)	■	■	■	■
	Crystal Bronze Pearl (001 295)	■	■	■	■
	Crystal Brown Pearl (001 815)	■	■	■	■
	Crystal Burgundy Pearl (001 301)	■	■	■	■
	Crystal Cream Pearl (001 620)	■	■	■	■
	Crystal Creamrose Pearl (001 621)	■	■	■	■
	Crystal Dark Grey Pearl (001 617)	■	■	■	■
	Crystal Gold Pearl (001 296)	■	■	■	■
	Crystal Grey Pearl (001 731)	■	■	■	■
	Crystal Iridescent Green Pearl (001 930)	■	■	■	■
	Crystal Lavender Pearl (001 524)	■	■	■	■
	Crystal Light Blue Pearl (001 302)	■	■	■	■
	Crystal Light Creamrose Pearl (001 618)	■	■	■	■
	Crystal Light Gold Pearl (001 539)	■	■	■	■
	Crystal Light Grey Pearl (001 616)	■	■	■	■
	Crystal Mauve Pearl (001 160)	■	■	■	■
	Crystal Night Blue Pearl (001 818)	■	■	■	■
	Crystal Peach Pearl (001 300)	■	■	■	■
	Crystal Petrol Pearl (001 600)	■	■	■	■
	Crystal Platinum Pearl (001 459)	■	■	■	■
	Crystal Powder Almond Pearl (001 305)	■	■	■	■
	Crystal Powder Rose Pearl (001 352)	■	■	■	■
	Crystal Rosaline Pearl (001 294)	■	■	■	■
	Crystal Rose Gold Pearl (001 769)	■	■	■	■
	Crystal Rose Peach Pearl (001 674)	■	■	■	■
	Crystal Tahitian-look Pearl (001 297)	■	■	■	■
	Crystal Vintage Gold Pearl (001 651)	■	■	■	■
	Crystal White Pearl (001 650)	■	■	■	■

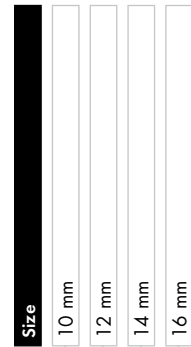

Gemcolors

	Crystal Coral Pearl (001 816)	■	■	■	■
	Crystal Dark Lapis Pearl (001 719)	■	■	■	■
	Crystal Ivory Pearl (001 708)	■	■	■	■
	Crystal Jade Pearl (001 715)	■	■	■	■
	Crystal Lapis Pearl (001 717)	■	■	■	■
	Crystal Mystic Black Pearl (001 335)	■	■	■	■
	Crystal Pink Coral Pearl (001 716)	■	■	■	■
	Crystal Red Coral Pearl (001 718)	■	■	■	■
	Crystal Turquoise Pearl (001 709)	■	■	■	■

Neoncolors

	Crystal Neon Green Pearl (001 771)	■	■	■	■
	Crystal Neon Orange Pearl (001 733)	■	■	■	■
	Crystal Neon Pink Pearl (001 732)	■	■	■	■
	Crystal Neon Red Pearl (001 770)	■	■	■	■
	Crystal Neon Yellow Pearl (001 734)	■	■	■	■

Crystal Pearls

5816

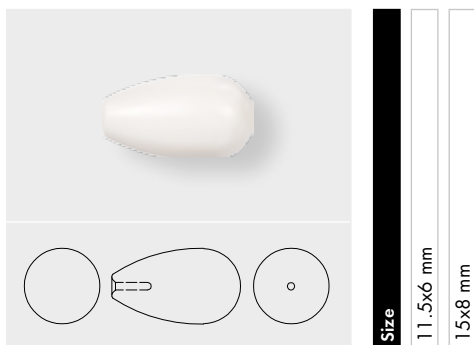

Colors	
Crystal Black Pearl (001 298)	■ ■
Crystal Blackberry Pearl (001 784)	■ ■
Crystal Bronze Pearl (001 295)	■ ■
Crystal Cream Pearl (001 620)	■ ■
Crystal Creamrose Pearl (001 621)	■ ■
Crystal Dark Grey Pearl (001 617)	■ ■
Crystal Grey Pearl (001 731)	■ ■
Crystal Iridescent Green Pearl (001 930)	■ ■
Crystal Lavender Pearl (001 524)	■ ■
Crystal Light Creamrose Pearl (001 618)	■ ■
Crystal Light Gold Pearl (001 539)	■ ■
Crystal Light Grey Pearl (001 616)	■ ■
Crystal Mauve Pearl (001 160)	■ ■
Crystal Peach Pearl (001 300)	■ ■
Crystal Petrol Pearl (001 600)	■ ■
Crystal Rosaline Pearl (001 294)	■ ■
Crystal Rose Gold Pearl (001 769)	■ ■
Crystal Rose Peach Pearl (001 674)	■ ■
Crystal Vintage Gold Pearl (001 651)	■ ■
Crystal White Pearl (001 650)	■ ■
Gemcolors	
Crystal Coral Pearl (001 816)	■ ■
Crystal Dark Lapis Pearl (001 719)	■ ■
Crystal Ivory Pearl (001 708)	■ ■
Crystal Jade Pearl (001 715)	■ ■
Crystal Lapis Pearl (001 717)	■ ■
Crystal Mystic Black Pearl (001 335)	■ ■
Crystal Pink Coral Pearl (001 716)	■ ■
Crystal Red Coral Pearl (001 718)	■ ■
Crystal Turquoise Pearl (001 709)	■ ■
Neoncolors	
Crystal Neon Green Pearl (001 771)	■ ■
Crystal Neon Orange Pearl (001 733)	■ ■
Crystal Neon Pink Pearl (001 732)	■ ■
Crystal Neon Red Pearl (001 770)	■ ■
Crystal Neon Yellow Pearl (001 734)	■ ■

5817

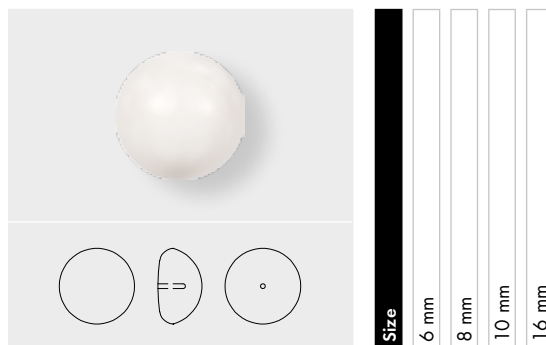

Colors	
Crystal Blackberry Pearl (001 784)	■ ■ ■ ■
Crystal Bronze Pearl (001 295)	■ ■ ■ ■
Crystal Cream Pearl (001 620)	■ ■ ■ ■
Crystal Creamrose Pearl (001 621)	■ ■ ■ ■
Crystal Dark Grey Pearl (001 617)	■ ■ ■ ■
Crystal Grey Pearl (001 731)	■ ■ ■ ■
Crystal Iridescent Green Pearl (001 930)	■ ■ ■ ■
Crystal Light Creamrose Pearl (001 618)	■ ■ ■ ■
Crystal Light Grey Pearl (001 616)	■ ■ ■ ■
Crystal Peach Pearl (001 300)	■ ■ ■ ■
Crystal Petrol Pearl (001 600)	■ ■ ■ ■
Crystal Rosaline Pearl (001 294)	■ ■ ■ ■
Crystal Rose Gold Pearl (001 769)	■ ■ ■ ■
Crystal Rose Peach Pearl (001 674)	■ ■ ■ ■
Crystal White Pearl (001 650)	■ ■ ■ ■
Gemcolors	
Crystal Coral Pearl (001 816)	■ ■ ■ ■
Crystal Dark Lapis Pearl (001 719)	■ ■ ■ ■
Crystal Ivory Pearl (001 708)	■ ■ ■ ■
Crystal Jade Pearl (001 715)	■ ■ ■ ■
Crystal Lapis Pearl (001 717)	■ ■ ■ ■
Crystal Mystic Black Pearl (001 335)	■ ■ ■ ■
Crystal Pink Coral Pearl (001 716)	■ ■ ■ ■
Crystal Red Coral Pearl (001 718)	■ ■ ■ ■
Crystal Turquoise Pearl (001 709)	■ ■ ■ ■
Neoncolors	
Crystal Neon Green Pearl (001 771)	■ ■ ■ ■
Crystal Neon Orange Pearl (001 733)	■ ■ ■ ■
Crystal Neon Pink Pearl (001 732)	■ ■ ■ ■
Crystal Neon Red Pearl (001 770)	■ ■ ■ ■
Crystal Neon Yellow Pearl (001 734)	■ ■ ■ ■

Crystal Pearls

5818

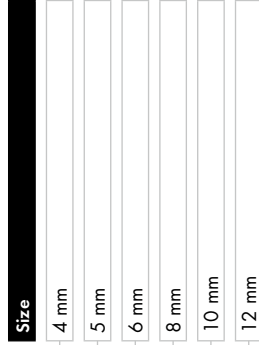
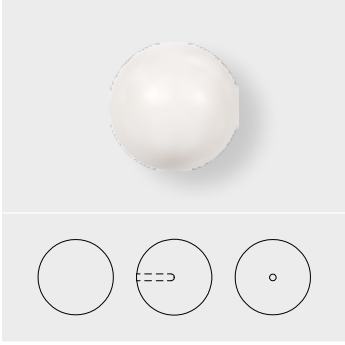

Colors

- Crystal Black Pearl (001 298)
- Crystal Blackberry Pearl (001 784)
- Crystal Bronze Pearl (001 295)
- Crystal Brown Pearl (001 815)
- Crystal Cream Pearl (001 620)
- Crystal Creamrose Pearl (001 621)
- Crystal Dark Grey Pearl (001 617)
- Crystal Gold Pearl (001 296)
- Crystal Grey Pearl (001 731)
- Crystal Iridescent Green Pearl (001 930)
- Crystal Lavender Pearl (001 524)
- Crystal Light Creamrose Pearl (001 618)
- Crystal Light Gold Pearl (001 539)
- Crystal Light Grey Pearl (001 616)
- Crystal Peach Pearl (001 300)
- Crystal Petrol Pearl (001 600)
- Crystal Platinum Pearl (001 459)
- Crystal Rosaline Pearl (001 294)
- Crystal Rose Gold Pearl (001 769)
- Crystal Rose Peach Pearl (001 674)
- Crystal Vintage Gold Pearl (001 651)
- Crystal White Pearl (001 650)

Gemcolors

- Crystal Coral Pearl (001 816)
- Crystal Dark Lapis Pearl (001 719)
- Crystal Ivory Pearl (001 708)
- Crystal Jade Pearl (001 715)
- Crystal Lapis Pearl (001 717)
- Crystal Mystic Black Pearl (001 335)
- Crystal Pink Coral Pearl (001 716)
- Crystal Red Coral Pearl (001 718)
- Crystal Turquoise Pearl (001 709)

Neoncolors

- Crystal Neon Green Pearl (001 771)
- Crystal Neon Orange Pearl (001 733)
- Crystal Neon Pink Pearl (001 732)
- Crystal Neon Red Pearl (001 770)
- Crystal Neon Yellow Pearl (001 734)

5821 Crystal Pear-shaped Pearl

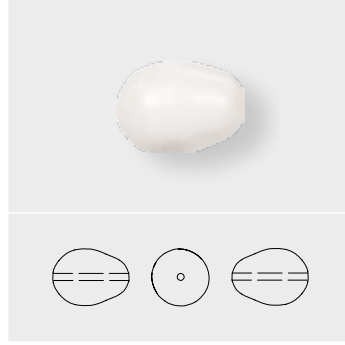

Colors

- Crystal Blackberry Pearl (001 784)
- Crystal Bronze Pearl (001 295)
- Crystal Cream Pearl (001 620)
- Crystal Creamrose Pearl (001 621)
- Crystal Dark Grey Pearl (001 617)
- Crystal Grey Pearl (001 731)
- Crystal Iridescent Green Pearl (001 930)
- Crystal Light Creamrose Pearl (001 618)
- Crystal Light Grey Pearl (001 616)
- Crystal Peach Pearl (001 300)
- Crystal Petrol Pearl (001 600)
- Crystal Rosaline Pearl (001 294)
- Crystal Rose Gold Pearl (001 769)
- Crystal Rose Peach Pearl (001 674)
- Crystal White Pearl (001 650)

Gemcolors

- Crystal Coral Pearl (001 816)
- Crystal Dark Lapis Pearl (001 719)
- Crystal Ivory Pearl (001 708)
- Crystal Jade Pearl (001 715)
- Crystal Lapis Pearl (001 717)
- Crystal Mystic Black Pearl (001 335)
- Crystal Pink Coral Pearl (001 716)
- Crystal Red Coral Pearl (001 718)
- Crystal Turquoise Pearl (001 709)

Neoncolors

- Crystal Neon Green Pearl (001 771)
- Crystal Neon Orange Pearl (001 733)
- Crystal Neon Pink Pearl (001 732)
- Crystal Neon Red Pearl (001 770)
- Crystal Neon Yellow Pearl (001 734)

Crystal Pearls

5840 Crystal Baroque Pearl

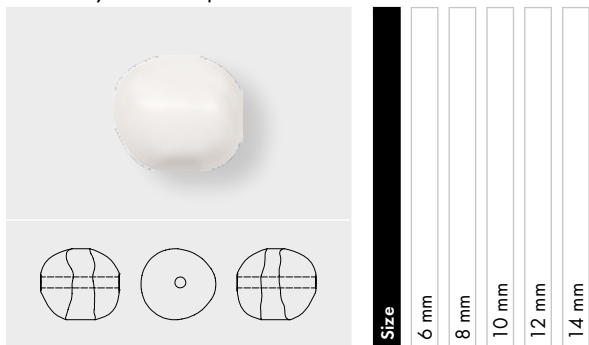

Colors	6 mm	8 mm	10 mm	12 mm	14 mm
Crystal Blackberry Pearl (001 784)	■	■	■	■	■
Crystal Bronze Pearl (001 295)	■	■	■	■	■
Crystal Cream Pearl (001 620)	■	■	■	■	■
Crystal Creamrose Pearl (001 621)	■	■	■	■	■
Crystal Dark Grey Pearl (001 617)	■	■	■	■	■
Crystal Grey Pearl (001 731)	■	■	■	■	■
Crystal Iridescent Green Pearl (001 930)	■	■	■	■	■
Crystal Light Creamrose Pearl (001 618)	■	■	■	■	■
Crystal Light Grey Pearl (001 616)	■	■	■	■	■
Crystal Petrol Pearl (001 600)	■	■	■	■	■
Crystal Rosaline Pearl (001 294)	■	■	■	■	■
Crystal Rose Gold Pearl (001 769)	■	■	■	■	■
Crystal Rose Peach Pearl (001 674)	■	■	■	■	■
Crystal White Pearl (001 650)	■	■	■	■	■
Gemcolors					
Crystal Coral Pearl (001 816)	■	■	■	■	■
Crystal Dark Lapis Pearl (001 719)	■	■	■	■	■
Crystal Ivory Pearl (001 708)	■	■	■	■	■
Crystal Jade Pearl (001 715)	■	■	■	■	■
Crystal Lapis Pearl (001 717)	■	■	■	■	■
Crystal Mystic Black Pearl (001 335)	■	■	■	■	■
Crystal Pink Coral Pearl (001 716)	■	■	■	■	■
Crystal Red Coral Pearl (001 718)	■	■	■	■	■
Crystal Turquoise Pearl (001 709)	■	■	■	■	■
Neoncolors					
Crystal Neon Green Pearl (001 771)	■	■	■	■	■
Crystal Neon Orange Pearl (001 733)	■	■	■	■	■
Crystal Neon Pink Pearl (001 732)	■	■	■	■	■
Crystal Neon Red Pearl (001 770)	■	■	■	■	■
Crystal Neon Yellow Pearl (001 734)	■	■	■	■	■

5860 Crystal Coin Pearl

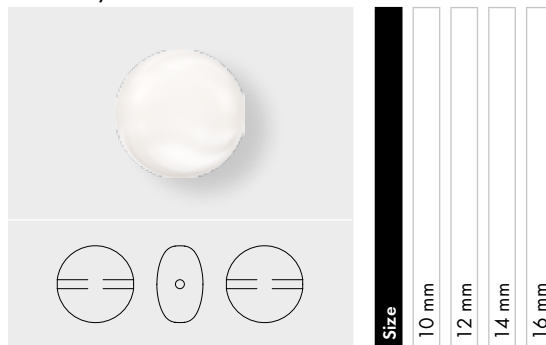

Colors	10 mm	12 mm	14 mm	16 mm
Crystal Black Pearl (001 298)	■	■	■	■
Crystal Blackberry Pearl (001 784)	■	■	■	■
Crystal Bordeaux Pearl (001 538)	■	■	■	■
Crystal Bright Gold Pearl (001 306)	■	■	■	■
Crystal Bronze Pearl (001 295)	■	■	■	■
Crystal Cream Pearl (001 620)	■	■	■	■
Crystal Creamrose Pearl (001 621)	■	■	■	■
Crystal Dark Grey Pearl (001 617)	■	■	■	■
Crystal Gold Pearl (001 296)	■	■	■	■
Crystal Grey Pearl (001 731)	■	■	■	■
Crystal Iridescent Green Pearl (001 930)	■	■	■	■
Crystal Lavender Pearl (001 524)	■	■	■	■
Crystal Light Creamrose Pearl (001 618)	■	■	■	■
Crystal Light Gold Pearl (001 539)	■	■	■	■
Crystal Light Grey Pearl (001 616)	■	■	■	■
Crystal Mauve Pearl (001 160)	■	■	■	■
Crystal Petrol Pearl (001 600)	■	■	■	■
Crystal Platinum Pearl (001 459)	■	■	■	■
Crystal Rosaline Pearl (001 294)	■	■	■	■
Crystal Rose Gold Pearl (001 769)	■	■	■	■
Crystal Rose Peach Pearl (001 674)	■	■	■	■
Crystal Vintage Gold Pearl (001 651)	■	■	■	■
Crystal White Pearl (001 650)	■	■	■	■
Gemcolors				
Crystal Coral Pearl (001 816)	■	■	■	■
Crystal Dark Lapis Pearl (001 719)	■	■	■	■
Crystal Ivory Pearl (001 708)	■	■	■	■
Crystal Jade Pearl (001 715)	■	■	■	■
Crystal Lapis Pearl (001 717)	■	■	■	■
Crystal Mystic Black Pearl (001 335)	■	■	■	■
Crystal Pink Coral Pearl (001 716)	■	■	■	■
Crystal Red Coral Pearl (001 718)	■	■	■	■
Crystal Turquoise Pearl (001 709)	■	■	■	■

Crystal Pearls

PRODUCT DETAILS

06 Crystal Pearls

Article Size	Packing Unit = Minimum Order Quantity in Pieces	Average Net Weight in Gram per Packing Unit Crystal (001)	Average Gross Weight in Gram per Packing Unit Crystal (001)
5810			
3 mm	1,000	38.5	53.5
4 mm	500	38.1	53.6
5 mm	500	83.7	99.2
6 mm	500	142.3	157.8
8 mm	250	173.7	188.9
10 mm	100	110.5	123.9
12 mm	100	191.7	205.1
5811			
10 mm	100	110.5	123.9
12 mm	100	191.7	205.1
14 mm	50	152.8	166.1
16 mm	25	140.68	154.05
5816			
11.5x6 mm	100	71.0	81.9
15x8 mm	100	117.2	128.1
5817			
6 mm	250	35.8	49.3
8 mm	250	97.9	111.2
10 mm	250	195.6	203.9
16 mm	100	269.5	282.9
5818			
4 mm	500	41.9	55.4
5 mm	500	87.9	101.4
6 mm	500	146.5	160.0
8 mm	250	177.9	191.1
10 mm	100	112.2	125.6
12 mm	100	187.5	200.9
5821			
11x8 mm	250	238.5	253.5
5840			
6 mm	500	125.55	139.05
8 mm	250	150.7	165.7
10 mm	100	128.9	140.8
12 mm	100	213.4	224.2
14 mm	50	154.4	166.4
5860			
10 mm	100	90.300	101.556
12 mm	100	153.636	164.892
14 mm	100	242.676	253.932
16 mm	50	176.820	188.034

Pendants

Pendants have timeless elegance and are available in a large range of classical and avant-garde cuts and shapes, as well as in many colors and effects. Pendants offer a whole range of design possibilities for different segments thanks to their easy application, with the hole on top requiring only a jump ring/pinch bail with a chain or cord. Because of the diverse range of sizes available, Pendants are ideal for creating jewelry sets such as necklace, bracelet, and earrings.

Pendants

SUMMARY

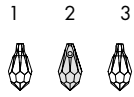

6000
11x5.5, 13x6.5, 15x7.5,
22x11, 28x14 mm

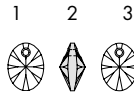

6028
8, 10, 12, 18 mm

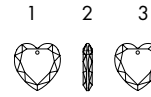

6225
10, 18, 28 mm



6002
10x7, 15x11.5 mm



6039
25, 38 mm



6228
10.3x10, 14.4x14,
18x17.5, 28, 40 mm



6007
7x4, 9x5 mm



6040
20, 30, 40 mm



6240
12, 17, 27, 37 mm



6010
11x5.5, 13x6.5,
17x8.5, 21x10.5,
50x21.5 mm



6041
18, 28, 38 mm



6260
17, 27, 37 mm



6012
11x10, 15.4x14 mm



6049
20, 30 mm



6261
17, 27, 36 mm



6015
17, 21, 50 mm



6090
16x11, 22x15 mm



6262
17, 26, 34 mm



6016/G
30, 56 mm



6100
24x12 mm



6264
18, 28, 36 mm



6017/G
30, 56 mm



6106
16, 22, 28, 38, 50 mm



6320
14, 19, 27 mm



6018/G
35 mm



6110
30x14, 40x18 mm

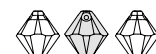

6328
6, 8, 10 mm



6019/G
35 mm



6128
8, 10, 12 mm



6401
8, 12 mm



6020
18, 30, 37 mm



6150
30, 50 mm



6428
6, 8, 12 mm



6022
14, 24, 33 mm



6210
12, 17 mm



6460
20 mm



6026
13, 20, 27 mm



6215
18 mm



6470
32, 40, 48 mm

1 Front view 2 Side view 3 Back view

If "1 Front view" or "3 Back view" highlighted in grey: the surface effect is applied on the respective side.

If "2 Side view" highlighted in grey: not defined on which side the surface effect is applied (for all symmetric and some asymmetric articles).

If all views are highlighted in grey, the effect is applied all over the marked surface.

Pendants

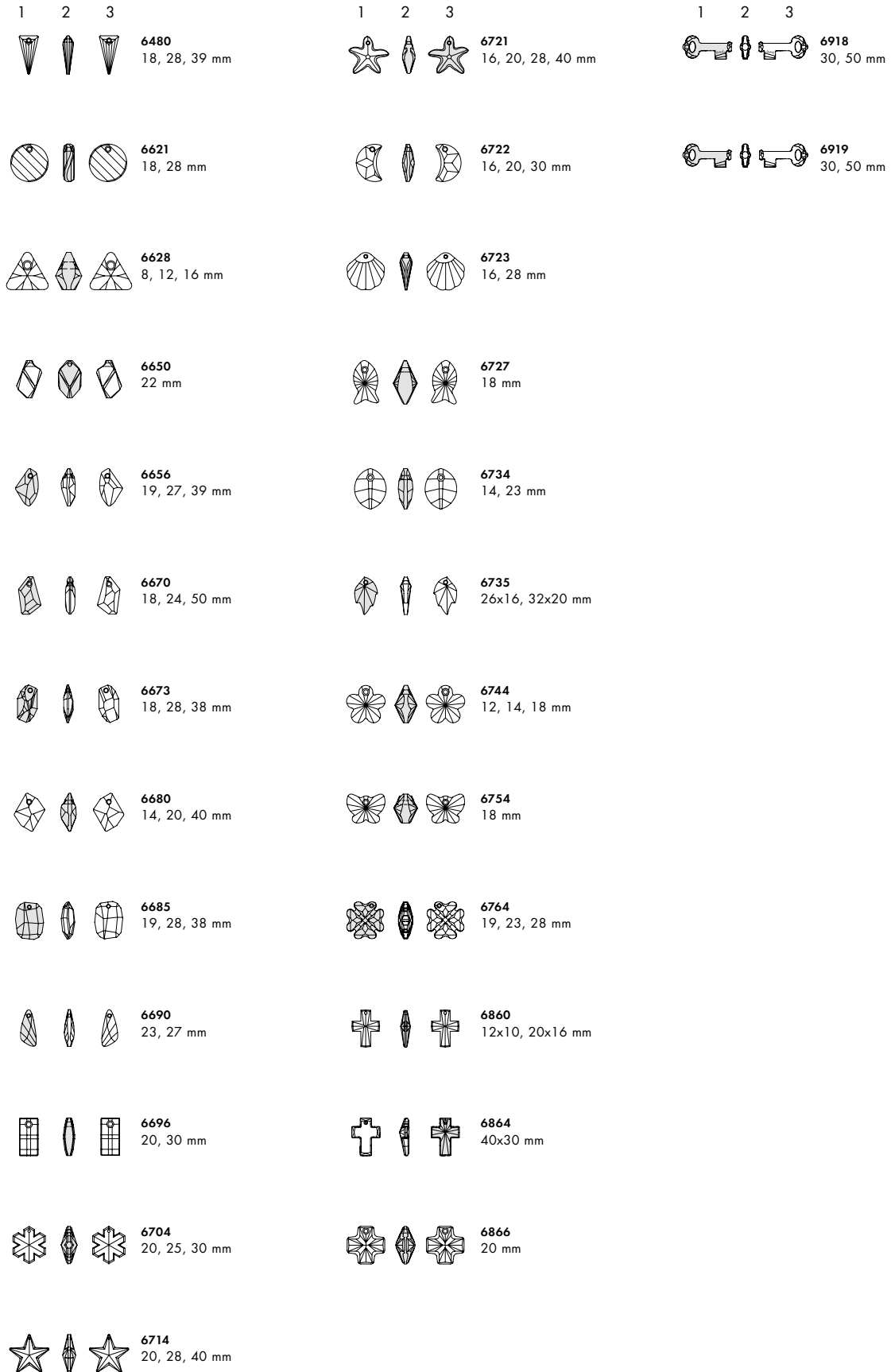

1 Front view 2 Side view 3 Back view

If "1 Front view" or "3 Back view" highlighted in grey: the surface effect is applied on the respective side.

If "2 Side view" highlighted in grey: not defined on which side the surface effect is applied (for all symmetric and some asymmetric articles).

6721: 16, 20 mm: no defined side for surface effect; 28, 40 mm surface effect on "3 Back view".

6864: Reverse effect "V" is the standard version and therefore highlighted.

Pendants

6000

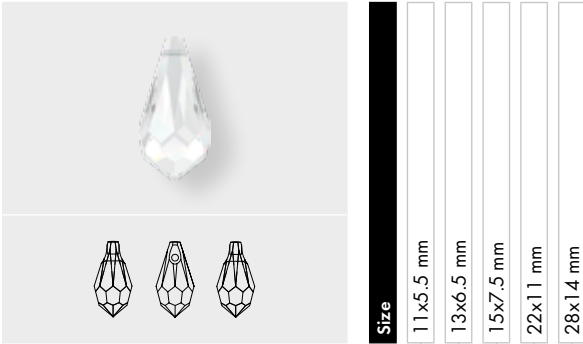

Crystal		11x5.5 mm	13x6.5 mm	15x7.5 mm	22x11 mm	28x14 mm
Crystal (001)		■	■	■	■	■
Colors						
Plain Colors						
Amethyst (204)		■				
Aquamarine (202)		■				
Emerald (205)		■				
Jet (280)		■	■	■		
Light Siam (227)		■				
Light Silk F (261)		■	■	■		
Light Turquoise (263)		■	■	■		
Rose (209)		■				
Sapphire (206)		■				
Siam (208)		■	■	■		
Tanzanite (539)		■				
Topaz (203)		■				
Crystal Effects						
Transparent Effects						
Crystal AB (001 AB)		■	■	■	■	■
Crystal Blue Shade (001 BLSH)		■	■	■		
Crystal Lilac Shadow (001 LISH)		■	■	■		

6002

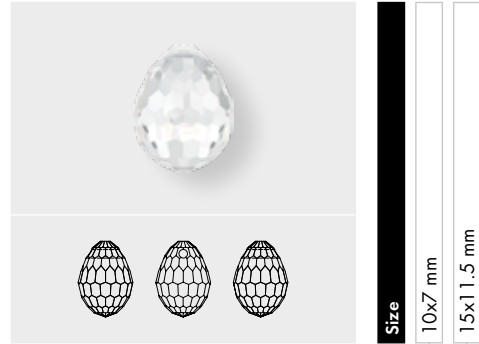

Crystal		10x7 mm	15x11.5 mm
Crystal (001)		■	■
Crystal Effects			
Transparent Effects			
Crystal AB (001 AB)		■	■

6007 Small Briolette Pendant

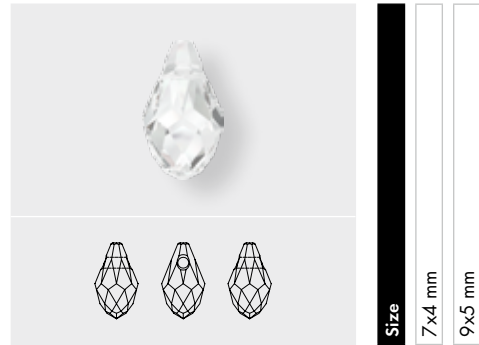

Crystal		7x4 mm	9x5 mm
Crystal (001)		■	■
Crystal Effects			
Transparent Effects			
Crystal AB (001 AB)		■	■
Crystal Golden Shadow (001 GSHA)		■	■

Pendants

6010 Briolette Pendant



Size	11x5.5 mm	13x6.5 mm	17x8.5 mm	21x10.5 mm	50x21.5 mm
------	-----------	-----------	-----------	------------	------------

Crystal

Crystal (001)	■	■	■	■	■
---------------	---	---	---	---	---

Colors

Plain Colors

Amethyst (204)	■	■	■		
Aquamarine (202)	■	■	■		
Dark Indigo (288)	■				
Dark Moss Green (260)	■	■			
Denim Blue (266)	■	■			
Erinite (360)	■	■	■		
Fuchsia (502)	■	■	■		
Indian Pink (289)	■				
Jet (280)	■	■			
Light Amethyst (212)	■	■	■		
Light Colorado Topaz (246)	■	■	■		
Light Rose (223)	■	■	■		
Light Sapphire (211)	■	■			
Light Silk (261)	■	■			
Light Turquoise (263)	■	■			
Padparadscha (542)	■	■			
Peridot (214)	■	■			
Provence Lavender (283)	■				
Rose Peach (262)	■	■			
Siam (208)	■	■			
Tanzanite (539)	■	■	■		
Tangerine (259)	■	■			

Opal Colors

Chrysolite Opal (294)	■	■			
-----------------------	---	---	--	--	--

Crystal Blend Colors

Burgundy-Blue Zircon Blend (723)	■	■			
Crystal-Montana Blend (725)	■	■			
Fern Green-Topaz Blend (724)	■	■			
Provence Lavender-Chrysolite Blend (726)	■	■			

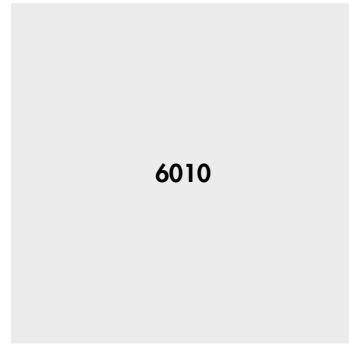

Size	11x5.5 mm	13x6.5 mm	17x8.5 mm	21x10.5 mm	50x21.5 mm
------	-----------	-----------	-----------	------------	------------

Crystal Effects

Transparent Effects

Crystal AB (001 AB)	■	■	■	■	■
Crystal Antique Pink (001 ANTP)	■	■			
Crystal Astral Pink (001 API)	■	■			
Crystal Blue Shade (001 BLSH)	■	■			
Crystal Golden Shadow (001 GSHA)	■	■	■	■	
Crystal Lilac Shadow (001 LISH)	■	■			
Crystal Luminous Green (001 LUMG)	■	■			
Crystal Silver Night (001 SINI)	■	■			
Crystal Silver Shade (001 SSHA)	■	■	■	■	

Metallic Effects

Crystal Iridescent Green (001 IRIG)	■	■			
-------------------------------------	---	---	--	--	--

Crystal Patina

Crystal Black Patina (001 BLAPA)	■	■	■		
Crystal Gold Patina (001 GOLPA)	■	■	■		
Crystal Rose Patina (001 ROSPA)	■	■	■		
Crystal Silver Patina (001 SILPA)	■	■	■		
Crystal White Patina (001 WHIPA)	■	■	■		

Pendants

6012 Flat Briolette Pendant

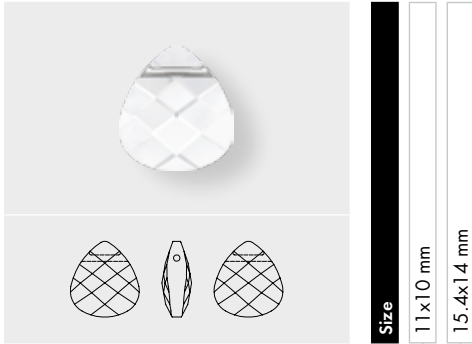

Size

11x10 mm

15.4x14 mm

Crystal

Crystal (001)

Colors

Plain Colors

Aquamarine (202)

Jet (280)

Olivine (228)

Ruby (501)

Crystal Effects

Transparent Effects

Crystal AB (001 AB)

Crystal Golden Shadow (001 GSHA)

6015 Polygon Drop

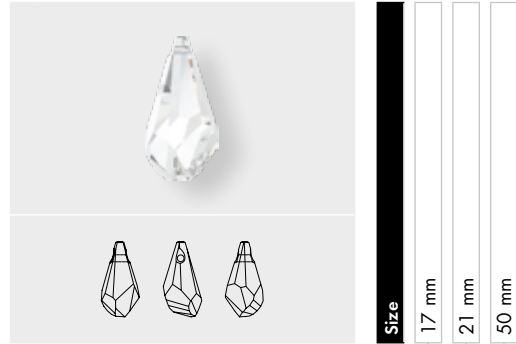

Size

17 mm

21 mm

50 mm

Crystal

Crystal (001)

Crystal Effects

Transparent Effects

Crystal AB (001 AB)

Crystal Golden Shadow (001 GSHA)

Pendants

6016/G The Grand Crystalactite partly frosted



Crystal		
Crystal (001)	<input type="checkbox"/>	<input type="checkbox"/>
Colors		
Plain Colors		
Jet (280)	<input type="checkbox"/>	<input type="checkbox"/>
Crystal Effects		
Transparent Effects		
Crystal AB V (001 AB V)	<input type="checkbox"/>	<input type="checkbox"/>
Crystal Antique Pink V (001 ANTP V)	<input type="checkbox"/>	<input type="checkbox"/>
Crystal Bermuda Blue P (001 BBL)*	<input type="checkbox"/>	<input type="checkbox"/>
Crystal Blue Shade V (001 BLSH V)	<input type="checkbox"/>	<input type="checkbox"/>
Crystal Bronze Shade V (001 BRSH V)	<input type="checkbox"/>	<input type="checkbox"/>
Crystal Copper V (001 COP V)	<input type="checkbox"/>	<input type="checkbox"/>
Crystal Golden Shadow V (001 GSHA V)	<input type="checkbox"/>	<input type="checkbox"/>
Crystal Silver Night (001 SINI)	<input type="checkbox"/>	<input type="checkbox"/>
Crystal Silver Shade V (001 SSHA V)	<input type="checkbox"/>	<input type="checkbox"/>
Crystal Vitrail Light P (001 VL)*	<input type="checkbox"/>	<input type="checkbox"/>
Crystal Vitrail Medium P (001 VM)*	<input type="checkbox"/>	<input type="checkbox"/>
Metallic Effects		
Crystal Comet Argent Light V P (001 CAL V)*	<input type="checkbox"/>	<input type="checkbox"/>

6017/G Crystalactite Pendant grand partly frosted



Crystal		
Crystal (001)	<input type="checkbox"/>	<input type="checkbox"/>
Colors		
Plain Colors		
Jet (280)	<input type="checkbox"/>	<input type="checkbox"/>
Crystal Effects		
Transparent Effects		
Crystal AB V (001 AB V)	<input type="checkbox"/>	<input type="checkbox"/>
Crystal Antique Pink V (001 ANTP V)	<input type="checkbox"/>	<input type="checkbox"/>
Crystal Bermuda Blue P (001 BBL)*	<input type="checkbox"/>	<input type="checkbox"/>
Crystal Blue Shade V (001 BLSH V)	<input type="checkbox"/>	<input type="checkbox"/>
Crystal Bronze Shade V (001 BRSH V)	<input type="checkbox"/>	<input type="checkbox"/>
Crystal Copper V (001 COP V)	<input type="checkbox"/>	<input type="checkbox"/>
Crystal Golden Shadow V (001 GSHA V)	<input type="checkbox"/>	<input type="checkbox"/>
Crystal Silver Night (001 SINI)	<input type="checkbox"/>	<input type="checkbox"/>
Crystal Silver Shade V (001 SSHA V)	<input type="checkbox"/>	<input type="checkbox"/>
Crystal Vitrail Light P (001 VL)*	<input type="checkbox"/>	<input type="checkbox"/>
Crystal Vitrail Medium P (001 VM)*	<input type="checkbox"/>	<input type="checkbox"/>
Metallic Effects		
Crystal Comet Argent Light V P (001 CAL V)*	<input type="checkbox"/>	<input type="checkbox"/>

* For details about the „protective layer“ please refer to page 24.

Pendants

6018/G The Petite Crystalactite partly frosted



- Crystal**
- Crystal (001)
- Colors**
- Plain Colors**
- Jet (280)
- Crystal Effects**
- Transparent Effects**
- Crystal AB V (001 AB V)
- Crystal Antique Pink V (001 ANTP V)
- Crystal Bermuda Blue P (001 BBL)*
- Crystal Blue Shade V (001 BLSH V)
- Crystal Bronze Shade V (001 BRSH V)
- Crystal Copper V (001 COP V)
- Crystal Golden Shadow V (001 GSHA V)
- Crystal Silver Night (001 SINI)
- Crystal Silver Shade V (001 SSHA V)
- Crystal Vitrail Light P (001 VL)*
- Crystal Vitrail Medium P (001 VM)*
- Metallic Effects**
- Crystal Comet Argent Light V P (001 CAL V)*

6019/G Crystalactite Pendant petite partly frosted



- Crystal**
- Crystal (001)
- Colors**
- Plain Colors**
- Jet (280)
- Crystal Effects**
- Transparent Effects**
- Crystal AB V (001 AB V)
- Crystal Antique Pink V (001 ANTP V)
- Crystal Bermuda Blue P (001 BBL)*
- Crystal Blue Shade V (001 BLSH V)
- Crystal Bronze Shade V (001 BRSH V)
- Crystal Copper V (001 COP V)
- Crystal Golden Shadow V (001 GSHA V)
- Crystal Silver Night (001 SINI)
- Crystal Silver Shade V (001 SSHA V)
- Crystal Vitrail Light P (001 VL)*
- Crystal Vitrail Medium P (001 VM)*
- Metallic Effects**
- Crystal Comet Argent Light V P (001 CAL V)*

* For details about the „protective layer“ please refer to page 24.

Pendants

6020 Helix Pendant

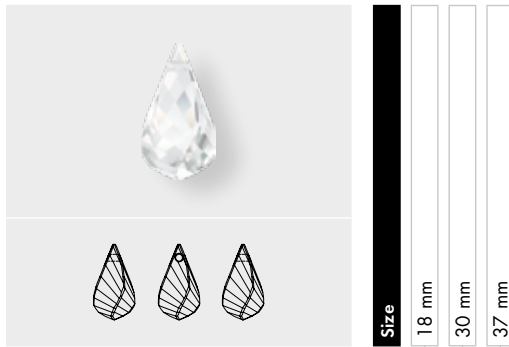

Crystal	18 mm	30 mm	37 mm
Crystal (001)	■	■	■
Crystal Effects			
Transparent Effects			
Crystal AB (001 AB)	■	■	■
Crystal Golden Shadow (001 GSHA)	■	■	■
Crystal Lilac Shadow (001 LISH)	■	■	■
Crystal Red Magma (001 REDM)	■	■	■
Crystal Silver Shade (001 SSHA)	■	■	■

6022 XIRIUS Raindrop Pendant

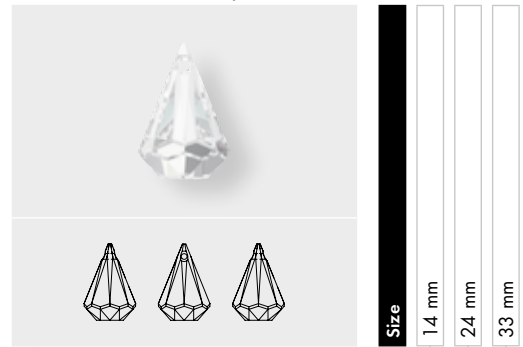

Crystal	14 mm	24 mm	33 mm
Crystal (001)	■	■	■
Colors			
Plain Colors			
Jet (280)	■	■	■
Crystal Effects			
Transparent Effects			
Crystal AB (001 AB)	■	■	■
Crystal Blue Shade (001 BLSH)	■	■	■
Crystal Bronze Shade (001 BRSH)	■	■	■
Crystal Golden Shadow (001 GSHA)	■	■	■
Crystal Luminous Green (001 LUMG)	■	■	■
Crystal Red Magma (001 REDM)	■	■	■
Crystal Satin (001 SAT)	■	■	■

Pendants

6026 Cabochette Pendant



Size	13 mm	20 mm	27 mm
------	-------	-------	-------

Crystal			
Crystal (001)	■	■	■
Colors			
Plain Colors			
Amethyst (204)	■	■	■
Black Diamond (215)	■	■	■
Dark Moss Green (260)	■	■	■
Fern Green (291)	■	■	■
Jet (280)	■	■	■
Light Silk (261)	■	■	■
Light Topaz (226)	■	■	■
Light Turquoise (263)	■	■	■
Crystal Effects			
Transparent Effects			
Crystal Blue Shade (001 BLSH)	■	■	■
Crystal Bronze Shade (001 BRSH)	■	■	■
Crystal Golden Shadow (001 GSHA)	■	■	■
Crystal Lilac Shadow (001 LISH)	■	■	■
Crystal Luminous Green (001 LUMG)	■	■	■
Crystal Satin (001 SAT)	■	■	■
Crystal Silver Shade (001 SSHA)	■	■	■
Metallic Effects			
Crystal Iridescent Green (001 IRIG)	■	■	■

6028 XILION Oval Pendant

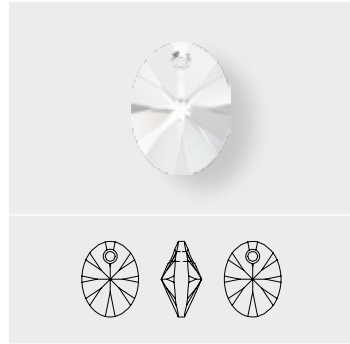

Size	8 mm	10 mm	12 mm	18 mm
------	------	-------	-------	-------

Crystal				
Crystal (001)	■	■	■	■
Colors				
Plain Colors				
Amethyst (204)	■	■	■	■
Dark Moss Green (260)	■	■	■	■
Erinite (360)	■	■	■	■
Indicolite (379)	■	■	■	■
Jet (280)	■	■	■	■
Light Rose (223)	■	■	■	■
Light Silk (261)	■	■	■	■
Montana (207)	■	■	■	■
Rose (209)	■	■	■	■
Sunflower (292)	■	■	■	■
Tangerine (259)	■	■	■	■
Crystal Effects				
Transparent Effects				
Crystal AB (001 AB)	■	■	■	■
Crystal Astral Pink (001 API)	■	■	■	■
Crystal Blue Shade (001 BLSH)	■	■	■	■
Crystal Golden Shadow (001 GSHA)	■	■	■	■
Crystal Lilac Shadow (001 LISH)	■	■	■	■
Crystal Luminous Green (001 LUMG)	■	■	■	■
Crystal Silver Night (001 SINI)	■	■	■	■
Crystal Vitrail Light P (001 VL)*	■	■	■	■
Metallic Effects				
Crystal Iridescent Green (001 IRIG)	■	■	■	■
Crystal Rose Gold (001 ROGL)	■	■	■	■
Crystal Rose Gold 2x (001 ROGL2X)	■	■	■	■

* For details about the „protective layer“ please refer to page 24.

Pendants

6039 Disk Pendant



Crystal	
Crystal (001)	<input type="checkbox"/>
Colors	
Plain Colors	
Aquamarine (202)	<input type="checkbox"/>
Crystal Effects	
Transparent Effects	
Crystal Astral Pink (001 API)	<input type="checkbox"/>
Crystal Bermuda Blue P (001 BBL)*	<input type="checkbox"/>
Crystal Golden Shadow (001 GSHA)	<input type="checkbox"/>
Crystal Lilac Shadow (001 LISH)	<input type="checkbox"/>
Crystal Luminous Green (001 LUMG)	<input type="checkbox"/>
Crystal Red Magma (001 REDM)	<input type="checkbox"/>
Crystal Silver Night (001 SINI)	<input type="checkbox"/>
Metallic Effects	
Crystal Iridescent Green (001 IRIG)	<input type="checkbox"/>

6040 Helios Pendant

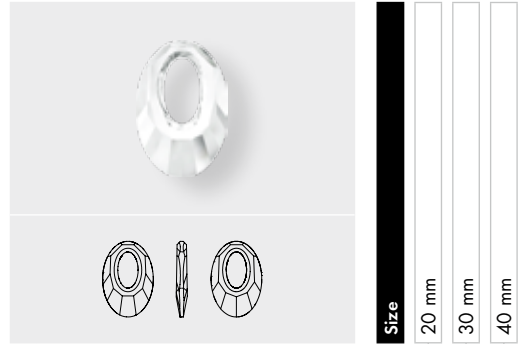

Crystal	
Crystal (001)	<input type="checkbox"/>
Colors	
Plain Color	
Indicolite (379)	<input type="checkbox"/>
Crystal Effects	
Transparent Effects	
Crystal AB (001 AB)	<input type="checkbox"/>
Crystal Antique Pink (001 ANTP)	<input type="checkbox"/>
Crystal Astral Pink (001 API)	<input type="checkbox"/>
Crystal Blue Shade (001 BLSH)	<input type="checkbox"/>
Crystal Golden Shadow (001 GSHA)	<input type="checkbox"/>
Crystal Lilac Shadow (001 LISH)	<input type="checkbox"/>
Crystal Luminous Green (001 LUMG)	<input type="checkbox"/>
Crystal Silver Night (001 SINI)	<input type="checkbox"/>
Crystal Vitrail Medium P (001 VM)*	<input type="checkbox"/>
Metallic Effects	
Crystal Comet Argent Light V P (001 CAL V)*	<input type="checkbox"/>
Crystal Iridescent Green (001 IRIG)	<input type="checkbox"/>
Crystal Patina	
Crystal Black Patina (001 BLAPA)	<input type="checkbox"/>
Crystal Gold Patina (001 GOLPA)	<input type="checkbox"/>
Crystal Rose Patina (001 ROSPA)	<input type="checkbox"/>
Crystal Silver Patina (001 SILPA)	<input type="checkbox"/>
Crystal White Patina (001 WHIPA)	<input type="checkbox"/>

Pendants

6041 Victory Pendant

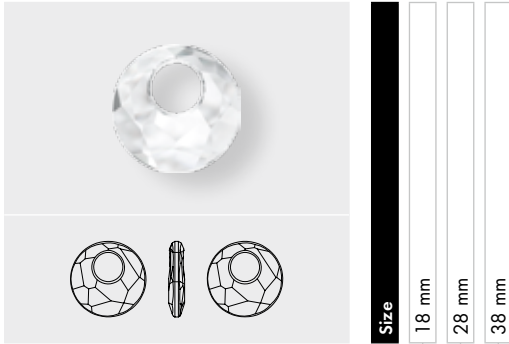

Crystal	18 mm	28 mm	38 mm
Crystal (001)	■	■	■
Colors			
Plain Colors			
Aquamarine (202)	■	■	■
Jet (280)	■	■	■
Crystal Effects			
Transparent Effects			
Crystal AB (001 AB)	■	■	■
Crystal Antique Pink (001 ANTP)	■	■	■
Crystal Bronze Shade (001 BRSH)	■	■	■
Crystal Golden Shadow (001 GSHA)	■	■	■
Crystal Lilac Shadow (001 LISH)	■	■	■
Crystal Red Magma (001 REDM)	■	■	■
Crystal Satin (001 SAT)	■	■	■
Metallic Effects			
Crystal Iridescent Green (001 IRIG)	■	■	■

6049

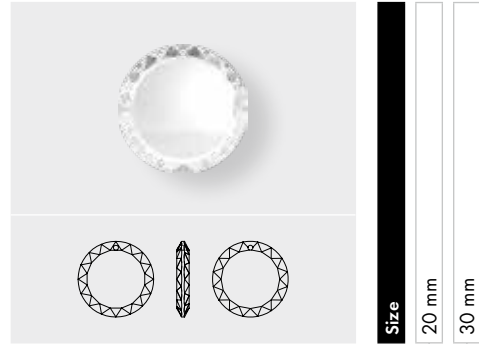

Crystal	20 mm	30 mm
Crystal (001)	■	■

Pendants

6090 Baroque Pendant

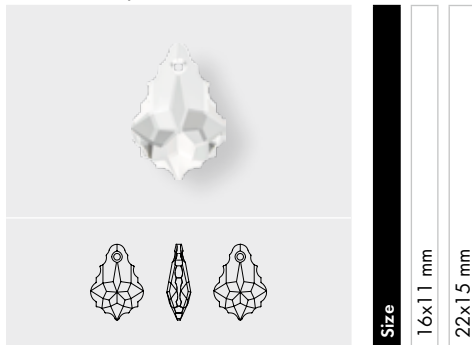

Size

16x11 mm

22x15 mm

Crystal

Crystal (001)

Colors

Plain Colors

Amethyst (204)

Aquamarine (202)

Black Diamond (215)

Jet (280)

Ruby (501)

Crystal Effects

Transparent Effects

Crystal AB (001 AB)

Crystal Golden Shadow (001 GSHA)

6100

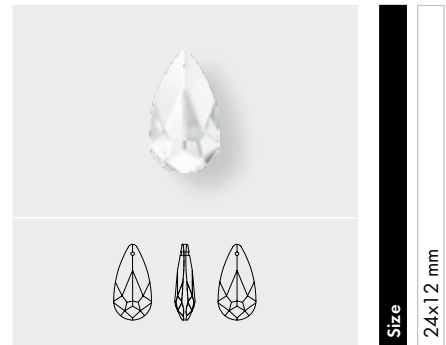

Size

24x12 mm

Crystal

Crystal (001)

Colors

Plain Colors

Fireopal (237)

Crystal Effects

Transparent Effects

Crystal AB (001 AB)

Crystal Bermuda Blue (001 BBL)

Crystal Vitrail Light (001 VL)

Crystal Vitrail Medium (001 VM)

Pendants

6106 Pear-shaped Pendant

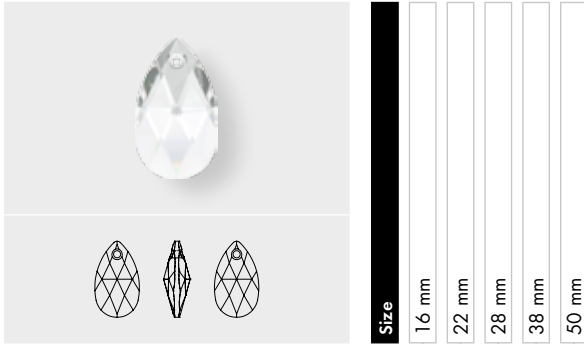

	16 mm	22 mm	28 mm	38 mm	50 mm
Crystal					
Crystal (001)	■	■	■	■	■
Colors					
Plain Colors					
Aquamarine (202)	■	■			
Dark Moss Green (260)	■	■			
Jet (280)	■	■			
Light Rose (223)	■	■			
Peridot (214)	■	■			
Ruby (501)	■	■			
Tanzanite (539)	■	■			
Crystal Blend Colors					
Amethyst Blend (721)	■	■			
Burgundy-Blue Zircon Blend (723)	■	■			
Crystal-Montana Blend (725)	■	■			
Fern Green-Topaz Blend (724)	■	■			
Provence Lavender-Chrysolite Blend (726)	■	■			
Crystal Effects					
Transparent Effects					
Crystal AB (001 AB)	■	■	■		
Crystal Antique Pink (001 ANTP)	■	■	■		
Crystal Astral Pink (001 API)	■	■	■		
Crystal Blue Shade (001 BLSH)	■	■	■		
Crystal Copper (001 COP)	■	■			
Crystal Golden Shadow (001 GSHA)	■	■	■	■	
Crystal Lilac Shadow (001 LISH)	■	■	■		
Crystal Luminous Green (001 LUMG)	■	■			
Crystal Silver Night (001 SINI)	■	■	■		
Crystal Silver Shade (001 SSHA)	■	■	■		
Metallic Effects					
Crystal Iridescent Green (001 IRIG)	■	■	■		
Crystal Patina					
Crystal Black Patina (001 BLAPA)	■	■	■		
Crystal Gold Patina (001 GOLPA)	■	■	■		
Crystal Rose Patina (001 ROSPA)	■	■	■		
Crystal Silver Patina (001 SILPA)	■	■	■		
Crystal White Patina (001 WHIPA)	■	■	■		

6110 Navette Pendant

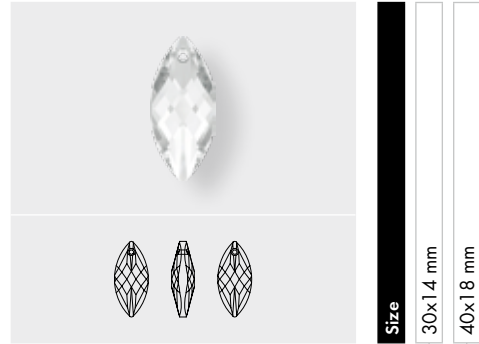

	30x14 mm	40x18 mm
Crystal		
Crystal (001)	■	■
Crystal Effects		
Transparent Effects		
Crystal Golden Shadow (001 GSHA)	■	■
Crystal Silver Shade (001 SSHA)	■	■

Pendants

6128 XILION Mini Pear Pendant

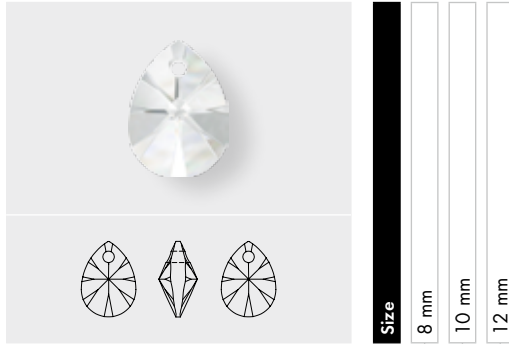

Crystal	8 mm	10 mm	12 mm
Crystal (001)	<input type="checkbox"/>	<input type="checkbox"/>	<input type="checkbox"/>
Colors			
Plain Colors			
Dark Moss Green (260)	<input type="checkbox"/>	<input type="checkbox"/>	<input type="checkbox"/>
Denim Blue (266)	<input type="checkbox"/>	<input type="checkbox"/>	<input type="checkbox"/>
Jet (280)	<input type="checkbox"/>	<input type="checkbox"/>	<input type="checkbox"/>
Light Silk (261)	<input type="checkbox"/>	<input type="checkbox"/>	<input type="checkbox"/>
Tangerine (259)	<input type="checkbox"/>	<input type="checkbox"/>	<input type="checkbox"/>
Crystal Effects			
Transparent Effects			
Crystal AB (001 AB)	<input type="checkbox"/>	<input type="checkbox"/>	<input type="checkbox"/>
Crystal Astral Pink (001 API)	<input type="checkbox"/>	<input type="checkbox"/>	<input type="checkbox"/>
Crystal Golden Shadow (001 GSHA)	<input type="checkbox"/>	<input type="checkbox"/>	<input type="checkbox"/>
Metallic Effects			
Crystal Iridescent Green (001 IRIG)	<input type="checkbox"/>	<input type="checkbox"/>	<input type="checkbox"/>
Crystal Rose Gold (001 ROGL)	<input type="checkbox"/>	<input type="checkbox"/>	<input type="checkbox"/>
Crystal Rose Gold 2x (001 ROGL2X)	<input type="checkbox"/>	<input type="checkbox"/>	<input type="checkbox"/>

6150 Pegasus Pendant

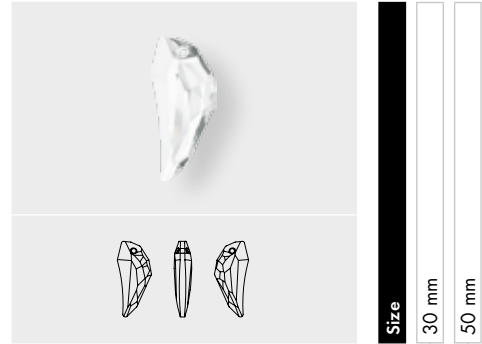

Crystal	30 mm	50 mm
Crystal (001)	<input type="checkbox"/>	<input type="checkbox"/>
Colors		
Plain Colors		
Jet (280)	<input type="checkbox"/>	<input type="checkbox"/>
Crystal Effects		
Transparent Effects		
Crystal Astral Pink (001 API)	<input type="checkbox"/>	<input type="checkbox"/>
Crystal Golden Shadow (001 GSHA)	<input type="checkbox"/>	<input type="checkbox"/>
Crystal Lilac Shadow (001 LISH)	<input type="checkbox"/>	<input type="checkbox"/>
Crystal Luminous Green (001 LUMG)	<input type="checkbox"/>	<input type="checkbox"/>
Crystal Satin (001 SAT)	<input type="checkbox"/>	<input type="checkbox"/>

Pendants

6210

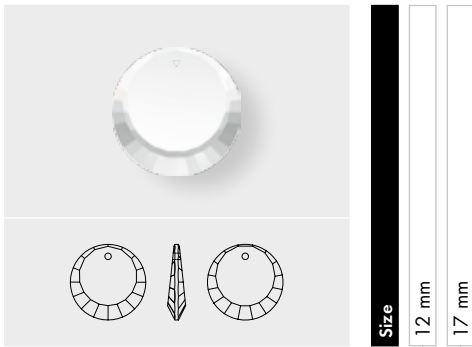

Size

12 mm

17 mm

Crystal

Crystal (001)

Crystal Effects

Transparent Effects

Crystal AB (001 AB)

6215

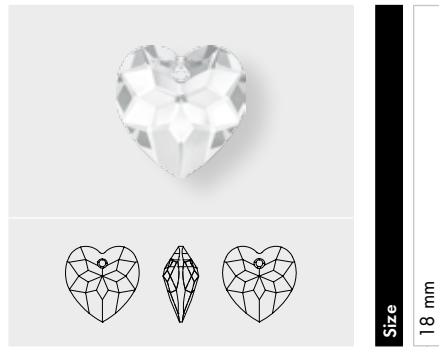

Size

18 mm

Crystal

Crystal (001)

Crystal Effects

Transparent Effects

Crystal AB (001 AB)

Crystal Astral Pink (001 API)

Crystal Bermuda Blue P (001 BBL)*

Crystal Red Magma (001 REDM)

6225

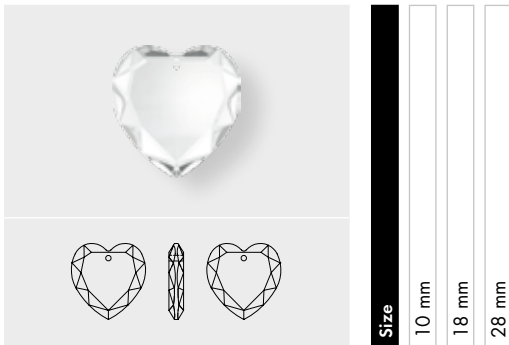

Size

10 mm

18 mm

28 mm

Crystal

Crystal (001)

* For details about the „protective layer“ please refer to page 24.

Pendants

6228 XILION Heart Pendant

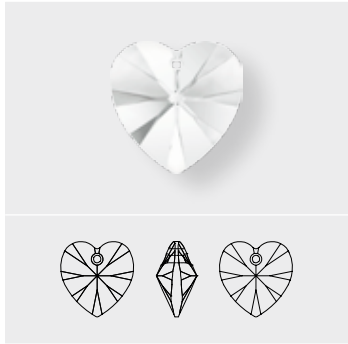

Size	10.3x10 mm	14.4x14 mm	18x17.5 mm	28 mm	40 mm
------	------------	------------	------------	-------	-------

Crystal	10.3x10 mm	14.4x14 mm	18x17.5 mm	28 mm	40 mm
Crystal (001)	■	■	■	■	■
Colors					
Plain Colors					
Amethyst (204)	■	■	■		
Aquamarine (202)	■	■	■		
Blue Zircon (229)	■	■	■		
Dark Moss Green (260)	■	■	■		
Denim Blue (266)	■	■	■		
Emerald (205)	■	■	■		
Fuchsia (502)	■	■	■		
Jet (280)	■	■	■		
Light Rose (223)	■	■	■		
Light Sapphire (211)	■	■	■	■	
Light Siam (227)	■	■	■		
Light Silk (261)	■	■	■		
Light Topaz (226)	■	■	■		
Light Turquoise (263)	■	■	■		
Padparadscha (542)	■	■	■		
Peridot (214)	■	■	■		
Provence Lavender (283)	■	■	■		
Rose (209)	■	■	■		
Sapphire (206)	■	■	■		
Siam (208)	■	■	■		
Tanzanite (539)	■	■	■		
Tangerine (259)	■	■	■		
Violet (371)	■	■	■		
Blend Colors					
Crystal-Montana Blend (Z25)	■	■			
Provence Lavender-Chrysolite Blend (Z26)	■	■			
Crystal Effects					
Transparent Effects					
Crystal AB (001 AB)	■	■	■	■	■
Crystal Antique Pink (001 ANTP)	■	■	■		
Crystal Astral Pink (001 API)	■	■	■	■	
Crystal Bermuda Blue (001 BBL)	■	■	■		
Crystal Bermuda Blue P (001 BBL)*	■	■	■		■
Crystal Blue Shade (001 BLSH)	■	■	■	■	
Crystal Golden Shadow (001 GSHA)	■	■	■	■	■
Crystal Heliotrope (001 HEL)	■	■	■		
Crystal Lilac Shadow (001 LISH)	■	■	■		

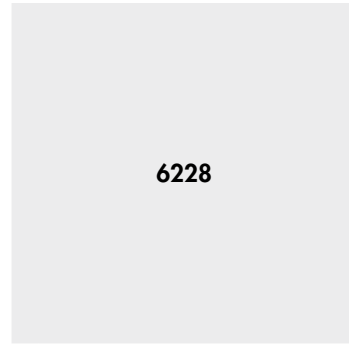

Size	10.3x10 mm	14.4x14 mm	18x17.5 mm	28 mm	40 mm
------	------------	------------	------------	-------	-------

Crystal	10.3x10 mm	14.4x14 mm	18x17.5 mm	28 mm	40 mm
Crystal Luminous Green (001 LUMG)	■	■	■	■	
Crystal Moonlight (001 MOL)	■	■	■	■	
Crystal Silver Night (001 SINI)	■	■	■	■	
Crystal Silver Shade (001 SSHA)	■	■	■	■	
Crystal Vitrail Light (001 VL)	■	■	■		
Crystal Vitrail Medium (001 VM)	■	■	■		
Metallic Effects					
Crystal Iridescent Green (001 IRIG)	■	■	■	■	
Crystal Rose Gold (001 ROGL)	■	■	■		
Crystal Rose Gold 2x (001 ROGL2X)	■	■	■		
Crystal Patina					
Crystal Black Patina (001 BLAPA)	■	■	■		
Crystal Gold Patina (001 GOLPA)	■	■	■		
Crystal Rose Patina (001 ROSPA)	■	■	■		
Crystal Silver Patina (001 SILPA)	■	■	■		
Crystal White Patina (001 WHIPA)	■	■	■		
Color Effects					
Transparent Effects					
Aquamarine AB (202 AB)	■	■	■		
Blue Zircon AB (229 AB)	■	■	■		
Fuchsia AB (502 AB)	■	■	■		
Light Rose AB (223 AB)	■	■	■		
Light Siam AB (227 AB)	■	■	■		
Light Topaz AB (226 AB)	■	■	■		
Peridot AB (214 AB)	■	■	■		
Rose AB (209 AB)	■	■	■		
Sapphire AB (206 AB)	■	■	■		
Siam AB (208 AB)	■	■	■		
Violet AB (371 AB)	■	■	■		

* For details about the „protective layer“ please refer to page 24.

Pendants

6240 Wild Heart Pendant

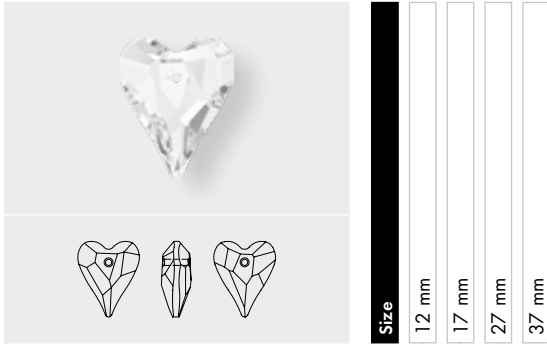

Crystal	12 mm	17 mm	27 mm	37 mm
Crystal (001)	■	■	■	■
Colors				
Plain Colors				
Aquamarine (202)	■	■	■	■
Rosaline (508)	■	■	■	■
Tanzanite (539)	■	■	■	■
Crystal Effects				
Transparent Effects				
Crystal AB (001 AB)	■	■	■	■
Crystal Antique Pink (001 ANTP)	■	■	■	■
Crystal Astral Pink (001 API)	■	■	■	■
Crystal Blue Shade (001 BLSH)	■	■	■	■
Crystal Golden Shadow (001 GSHA)	■	■	■	■
Crystal Lilac Shadow (001 LISH)	■	■	■	■
Crystal Luminous Green (001 LUMG)	■	■	■	■
Crystal Red Magma (001 REDM)	■	■	■	■
Crystal Vitrail Medium P (001 VM)*	■	■	■	■
Metallic Effects				
Crystal Comet Argent Light V P (001 CAL V)*	■	■	■	■
Crystal Iridescent Green (001 IRIG)	■	■	■	■
Crystal Patina				
Crystal Black Patina (001 BLAPA)	■	■	■	■
Crystal Gold Patina (001 GOLPA)	■	■	■	■
Crystal Rose Patina (001 ROSPA)	■	■	■	■
Crystal Silver Patina (001 SILPA)	■	■	■	■
Crystal White Patina (001 WHIPA)	■	■	■	■

6260 Crazy 4 U Heart

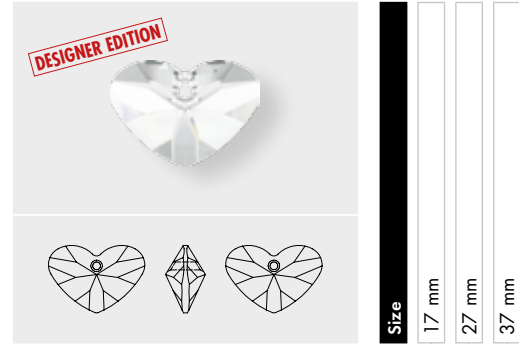

Crystal	17 mm	27 mm	37 mm
Crystal (001)	■	■	■
Crystal Effects			
Transparent Effects			
Crystal AB (001 AB)	■	■	■
Crystal Antique Pink (001 ANTP)	■	■	■
Crystal Astral Pink (001 API)	■	■	■
Crystal Golden Shadow (001 GSHA)	■	■	■
Crystal Satin (001 SAT)	■	■	■

* For details about the „protective layer“ please refer to page 24.

Pendants

6261 Devoted 2 U Heart

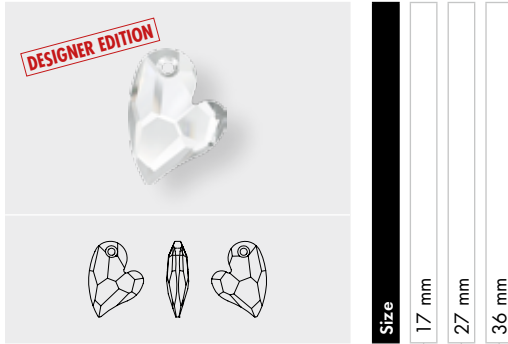

Crystal	17 mm	27 mm	36 mm
Crystal (001)	■	■	■
Colors			
Plain Colors			
Amethyst (204)	■		
Aquamarine (202)	■		
Jet (280)	■	■	
Rosaline (508)	■		
Crystal Effects			
Transparent Effects			
Crystal AB (001 AB)	■	■	■
Crystal Antique Pink (001 ANTP)	■	■	■
Crystal Astral Pink (001 API)	■	■	■
Crystal Bermuda Blue P (001 BBL)*			■
Crystal Blue Shade (001 BLSH)	■	■	■
Crystal Golden Shadow (001 GSHA)	■	■	■
Crystal Lilac Shadow (001 LISH)	■	■	■
Crystal Red Magma (001 REDM)	■	■	■
Crystal Satin (001 SAT)	■	■	
Crystal Vitrail Medium P (001 VM)*	■	■	
Metallic Effects			
Crystal Comet Argent Light V P (001 CAL V)*	■	■	

6262 Miss U Heart

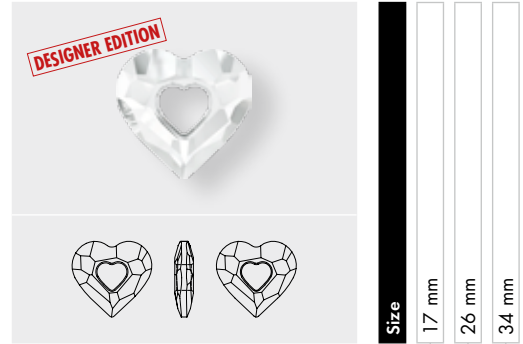

Crystal	17 mm	26 mm	34 mm
Crystal (001)	■	■	■
Colors			
Plain Colors			
Amethyst (204)	■		
Crystal Effects			
Transparent Effects			
Crystal AB (001 AB)	■	■	■
Crystal Antique Pink (001 ANTP)	■	■	■
Crystal Astral Pink (001 API)	■	■	■
Crystal Golden Shadow (001 GSHA)	■	■	■
Crystal Lilac Shadow (001 LISH)	■	■	■
Crystal Satin (001 SAT)	■	■	

* For details about the „protective layer“ please refer to page 24.

Pendants

6264 Truly in Love Heart

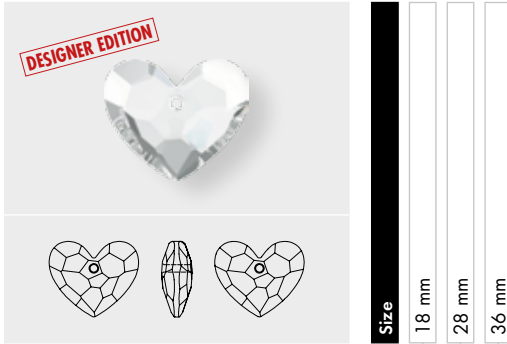

Size
18 mm
28 mm
36 mm

Crystal

Crystal (001)

Crystal Effects

Transparent Effects

Crystal AB (001 AB)

Crystal Antique Pink (001 ANTP)

Crystal Astral Pink (001 API)

Crystal Bermuda Blue P (001 BBL)*

Crystal Golden Shadow (001 GSHA)

Crystal Lilac Shadow (001 LISH)

Crystal Red Magma (001 REDM)

Crystal Satin (001 SAT)

6320 Rhombus Pendant

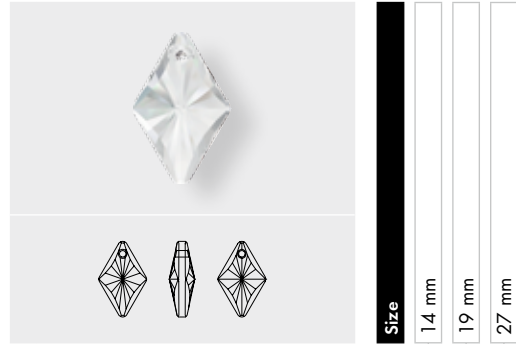

Size
14 mm
19 mm
27 mm

Crystal

Crystal (001)

Crystal Effects

Transparent Effects

Crystal AB (001 AB)

Crystal Golden Shadow (001 GSHA)

Crystal Lilac Shadow (001 LISH)

* For details about the „protective layer“ please refer to page 24.

Pendants

6328 XILION Bi-Cone Pendant

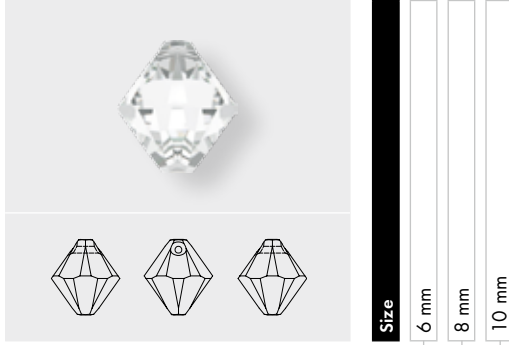

Crystal	6 mm	8 mm	10 mm
Crystal (001)	■	■	
Colors			
Plain Colors			
Aquamarine (202)	■	■	
Dark Moss Green (260)	■	■	
Light Rose (223)	■	■	
Light Silk (261)	■	■	
Light Turquoise (263)	■	■	
Provence Lavender (283)	■	■	
Rose (209)	■	■	
Tangerine (259)	■	■	
Violet (371)	■	■	
Crystal Effects			
Transparent Effects			
Crystal AB (001 AB)	■	■	
Crystal Blue Shade (001 BLSH)	■	■	
Crystal Golden Shadow (001 GSHA)	■	■	
Metallic Effects			
Crystal Iridescent Green (001 IRIG)	■	■	■
Crystal Rose Gold 2x (001 ROGL2X)	■	■	■

6401 Octagon Pendant

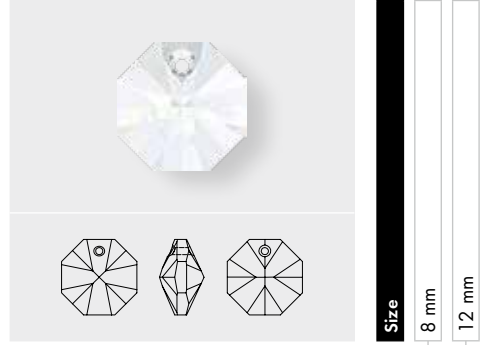

Crystal	8 mm	12 mm
Crystal (001)	■	■
Colors		
Plain Colors		
Aquamarine (202)	■	■
Light Rose (223)	■	■
Tanzanite (539)	■	■
Crystal Effects		
Transparent Effects		
Crystal AB (001 AB)	■	■
Crystal Copper (001 COP)	■	■
Crystal Golden Shadow (001 GSHA)	■	■
Crystal Silver Shade (001 SSHA)	■	■

Pendants

6428 XILION Pendant

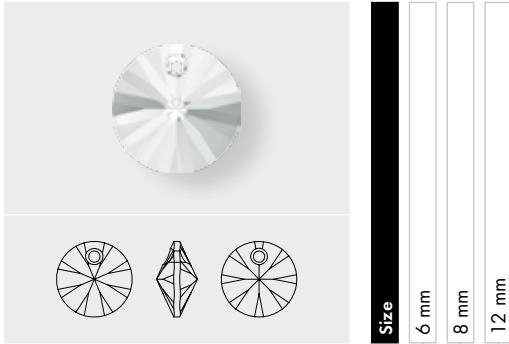

Crystal	6 mm	8 mm	12 mm
Crystal (001)	■	■	■
Colors			
Plain Colors			
Amethyst (204)	■	■	■
Aquamarine (202)	■	■	■
Dark Moss Green (260)	■	■	■
Denim Blue (266)	■	■	■
Jet (280)	■	■	■
Light Colorado Topaz (246)	■	■	■
Light Siam (227)	■	■	■
Light Silk (261)	■	■	■
Light Turquoise (263)	■	■	■
Rose (209)	■	■	■
Rose Peach (262)	■	■	■
Siam (208)	■	■	■
Tangerine (259)	■	■	■
Violet (371)	■	■	■
Crystal Effects			
Transparent Effects			
Crystal AB (001 AB)	■	■	■
Crystal Antique Pink (001 ANTP)	■	■	■
Crystal Astral Pink (001 API)	■	■	■
Crystal Blue Shade (001 BLSH)	■	■	■
Crystal Bronze Shade (001 BRSH)	■	■	■
Crystal Golden Shadow (001 GSHA)	■	■	■
Crystal Lilac Shadow (001 LISH)	■	■	■
Crystal Luminous Green (001 LUMG)	■	■	■
Crystal Silver Night (001 SINI)	■	■	■
Crystal Silver Shade (001 SSHA)	■	■	■
Metallic Effects			
Crystal Iridescent Green (001 IRIG)	■	■	■
Crystal Metallic Light Gold 2x (001 MLG2)	■	■	■
Crystal Rose Gold (001 ROGL)	■	■	■
Crystal Rose Gold 2x (001 ROGL2X)	■	■	■
Crystal Patina			
Crystal Black Patina (001 BLAPA)	■	■	■
Crystal Gold Patina (001 GOLPA)	■	■	■
Crystal Rose Patina (001 ROSPA)	■	■	■
Crystal Silver Patina (001 SILPA)	■	■	■
Crystal White Patina (001 WHIPA)	■	■	■

6460 Column Pendant

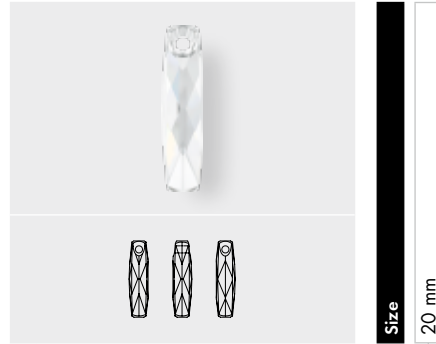

Crystal	20 mm
Crystal (001)	■
Crystal Effects	
Transparent Effects	
Crystal AB (001 AB)	■
Crystal Golden Shadow (001 GSHA)	■
Crystal Silver Shade (001 SSHA)	■

6470 Ellipse Pendant

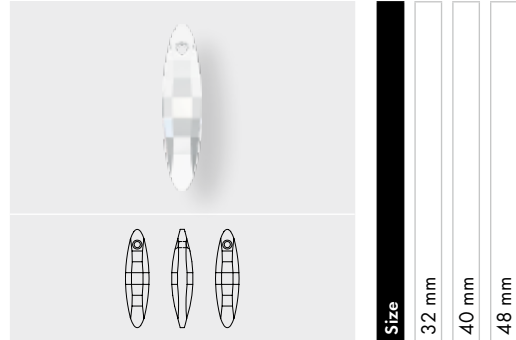

Crystal	32 mm	40 mm	48 mm
Crystal (001)	■	■	■
Colors			
Plain Colors			
Aquamarine (202)	■	■	■
Light Amethyst (212)	■	■	■
Olivine (228)	■	■	■
Crystal Effects			
Transparent Effects			
Crystal AB (001 AB)	■	■	■
Crystal Astral Pink (001 API)	■	■	■
Crystal Golden Shadow (001 GSHA)	■	■	■
Crystal Red Magma (001 REDM)	■	■	■
Crystal Satin (001 SAT)	■	■	■
Crystal Silver Shade (001 SSHA)	■	■	■
Metallic Effects			
Crystal Iridescent Green (001 IRIG)	■	■	■

Pendants

6480 Spike Pendant

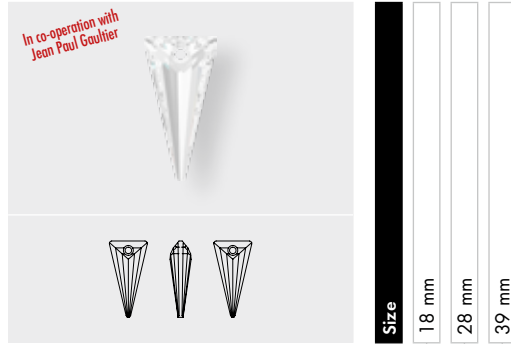

	18 mm	28 mm	39 mm
Crystal			
Crystal (001)	■	■	■
Colors			
Plain Colors			
Jet (280)	■	■	■
Crystal Effects			
Transparent Effects			
Crystal AB (001 AB)	■	■	■
Crystal Antique Pink (001 ANTP)	■	■	■
Crystal Astral Pink (001 API)	■	■	■
Crystal Bermuda Blue P (001 BBL)*	■	■	■
Crystal Blue Shade (001 BLSH)	■	■	■
Crystal Bronze Shade (001 BRSH)	■	■	■
Crystal Golden Shadow (001 GSHA)	■	■	■
Crystal Luminous Green (001 LUMG)	■	■	■
Crystal Red Magma (001 REDM)	■	■	■
Crystal Silver Night (001 SINI)	■	■	■
Crystal Silver Shade (001 SSHA)	■	■	■
Crystal Vitrail Medium P (001 VM)*	■	■	■
Crystal Patina			
Crystal Black Patina (001 BLAPA)	■	■	■
Crystal Gold Patina (001 GOLPA)	■	■	■
Crystal Rose Patina (001 ROSPA)	■	■	■
Crystal Silver Patina (001 SILPA)	■	■	■
Crystal White Patina (001 WHIPA)	■	■	■

6621 Twist Pendant

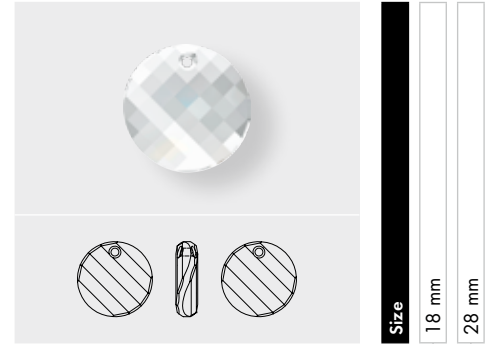

	18 mm	28 mm
Crystal		
Crystal (001)	■	■
Colors		
Plain Colors		
Amethyst (204)	■	■
Aquamarine (202)	■	■
Black Diamond (215)	■	■
Crystal Effects		
Transparent Effects		
Crystal Astral Pink (001 API)	■	■
Crystal Bermuda Blue P (001 BBL)*	■	■
Crystal Blue Shade (001 BLSH)	■	■
Crystal Golden Shadow (001 GSHA)	■	■
Crystal Moonlight (001 MOL)	■	■
Crystal Silver Night (001 SINI)	■	■
Crystal Silver Shade (001 SSHA)	■	■
Crystal Tabac P (001 TAB)*	■	■
Crystal Vitrail Medium P (001 VM)*	■	■
Metallic Effects		
Crystal Comet Argent Light V P (001 CAL V)*	■	■

* For details about the „protective layer“ please refer to page 24.

Pendants

6628 XILION Triangle Pendant

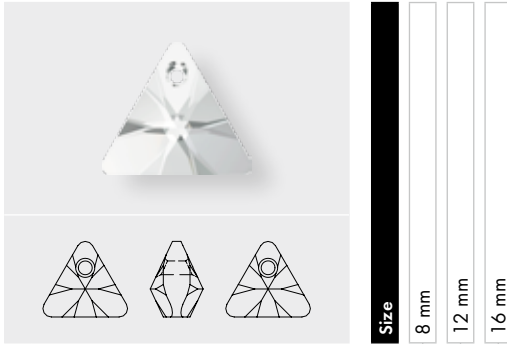

Crystal	8 mm	12 mm	16 mm
Crystal (001)	■	■	■
Colors			
Plain Colors			
Aquamarine (202)	■	■	■
Dark Moss Green (260)	■	■	■
Jet (280)	■	■	■
Light Rose (223)	■	■	■
Light Topaz (226)	■	■	■
Tangerine (259)	■	■	■
Violet (371)	■	■	■
Crystal Effects			
Transparent Effects			
Crystal AB (001 AB)	■	■	■
Crystal Bermuda Blue P (001 BBL)*	■	■	■
Crystal Blue Shade (001 BLSH)	■	■	■
Crystal Golden Shadow (001 GSHA)	■	■	■
Crystal Lilac Shadow (001 LISH)	■	■	■
Crystal Luminous Green (001 LUMG)	■	■	■
Crystal Red Magma (001 REDM)	■	■	■
Crystal Silver Night (001 SINI)	■	■	■
Crystal Silver Shade (001 SSHA)	■	■	■
Crystal Vitrail Light P (001 VL)*	■	■	■
Metallic Effects			
Crystal Iridescent Green (001 IRIG)	■	■	■

6650 Cubist Pendant

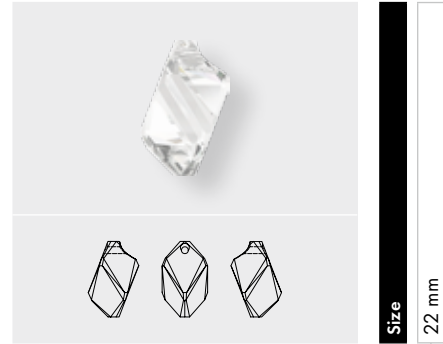

Crystal	22 mm
Crystal (001)	■
Colors	
Plain Colors	
Black Diamond (215)	■
Burgundy (515)	■
Light Amethyst (212)	■
Light Sapphire (211)	■
Peridot (214)	■
Crystal Effects	
Transparent Effects	
Crystal Golden Shadow (001 GSHA)	■
Crystal Moonlight (001 MOL)	■
Crystal Silver Shade (001 SSHA)	■

* For details about the „protective layer“ please refer to page 24.

Pendants

6656 Galactic Vertical Pendant

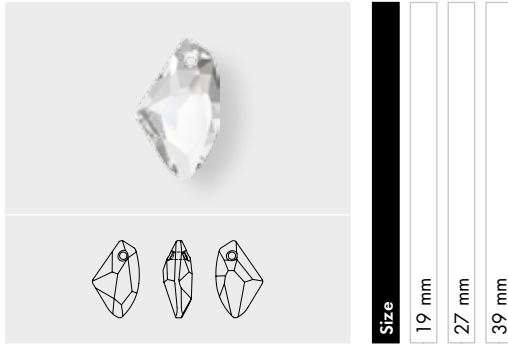

Crystal	19 mm	27 mm	39 mm
Crystal (001)	■	■	■
Colors			
Plain Colors			
Aquamarine (202)	■	■	
Jet (280)	■	■	
Light Rose (223)	■	■	
Peridot (214)	■	■	
Tanzanite (539)	■	■	
Crystal Effects			
Transparent Effects			
Crystal Antique Pink (001 ANTP)	■	■	
Crystal Astral Pink (001 API)	■	■	■
Crystal Bermuda Blue P (001 BBL)*	■	■	■
Crystal Blue Shade (001 BLSH)	■	■	■
Crystal Golden Shadow (001 GSHA)	■	■	■
Crystal Lilac Shadow (001 LISH)	■	■	■
Crystal Luminous Green (001 LUMG)	■	■	■
Crystal Moonlight (001 MOL)	■	■	■
Crystal Red Magma (001 REDM)	■	■	■
Crystal Silver Shade (001 SSHA)	■	■	■
Crystal Vitrail Medium P (001 VM)*	■	■	
Metallic Effects			
Crystal Comet Argent Light V P (001 CAL V)*	■	■	

6670 De-Art Pendant



Crystal	18 mm	24 mm	50 mm
Crystal (001)	■	■	■
Colors			
Plain Colors			
Amethyst (204)	■	■	
Aquamarine (202)	■	■	
Jet (280)	■	■	■
Montana (207)	■	■	
Crystal Effects			
Transparent Effects			
Crystal AB (001 AB)	■	■	
Crystal Astral Pink (001 API)	■	■	■
Crystal Bermuda Blue P (001 BBL)*	■	■	■
Crystal Golden Shadow (001 GSHA)	■	■	■
Crystal Silver Night (001 SINI)	■	■	■

* For details about the „protective layer“ please refer to page 24.

Pendants

6673 Meteor Pendant

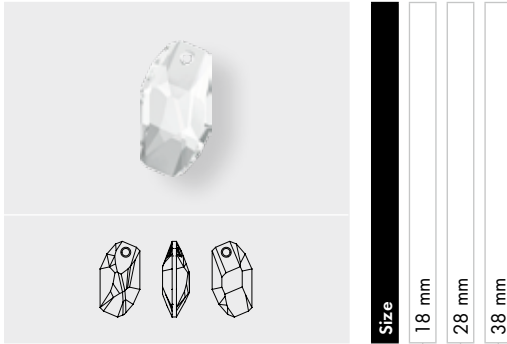

Size
18 mm
28 mm
38 mm

Crystal		
<input type="checkbox"/>	Crystal (001)	<input type="checkbox"/>
Colors		
Plain Colors		
<input type="checkbox"/>	Jet (280)	<input type="checkbox"/>
<input type="checkbox"/>	Light Turquoise (263)	<input type="checkbox"/>
<input type="checkbox"/>	Tanzanite (539)	<input type="checkbox"/>
Crystal Effects		
Transparent Effects		
<input type="checkbox"/>	Crystal AB (001 AB)	<input type="checkbox"/>
<input type="checkbox"/>	Crystal Antique Pink (001 ANTP)	<input type="checkbox"/>
<input type="checkbox"/>	Crystal Blue Shade (001 BLSH)	<input type="checkbox"/>
<input type="checkbox"/>	Crystal Golden Shadow (001 GSHA)	<input type="checkbox"/>
<input type="checkbox"/>	Crystal Lilac Shadow (001 LISH)	<input type="checkbox"/>
<input type="checkbox"/>	Crystal Luminous Green (001 LUMG)	<input type="checkbox"/>
<input type="checkbox"/>	Crystal Red Magma (001 REDM)	<input type="checkbox"/>
<input type="checkbox"/>	Crystal Silver Shade (001 SSHA)	<input type="checkbox"/>
Metallic Effects		
<input type="checkbox"/>	Crystal Iridescent Green (001 IRIG)	<input type="checkbox"/>

6680 Cosmic Pendant

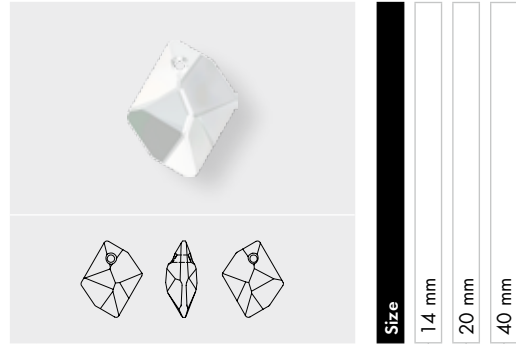

Size
14 mm
20 mm
40 mm

Crystal		
<input type="checkbox"/>	Crystal (001)	<input type="checkbox"/>
Colors		
Plain Colors		
<input type="checkbox"/>	Aquamarine (202)	<input type="checkbox"/>
<input type="checkbox"/>	Violet (371)	<input type="checkbox"/>
Crystal Effects		
Transparent Effects		
<input type="checkbox"/>	Crystal AB (001 AB)	<input type="checkbox"/>
<input type="checkbox"/>	Crystal Golden Shadow (001 GSHA)	<input type="checkbox"/>

Pendants

6685 Graphic Pendant

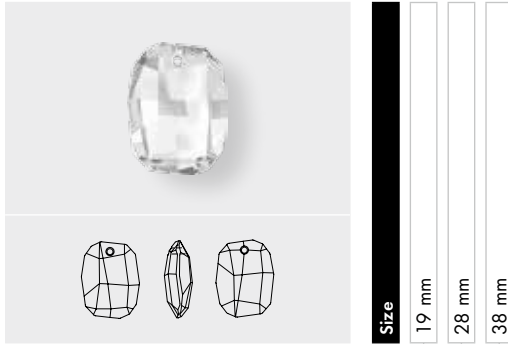

Crystal	
<input type="checkbox"/> Crystal (001)	<input type="checkbox"/> <input type="checkbox"/> <input type="checkbox"/>
Colors	
Plain Colors	
<input type="checkbox"/> Amethyst (204)	<input type="checkbox"/> <input type="checkbox"/>
<input type="checkbox"/> Aquamarine (202)	<input type="checkbox"/> <input type="checkbox"/>
<input type="checkbox"/> Denim Blue (266)	<input type="checkbox"/> <input type="checkbox"/>
<input type="checkbox"/> Emerald (205)	<input type="checkbox"/> <input type="checkbox"/>
<input type="checkbox"/> Light Amethyst (212)	<input type="checkbox"/> <input type="checkbox"/>
Crystal Effects	
Transparent Effects	
<input type="checkbox"/> Crystal AB (001 AB)	<input type="checkbox"/> <input type="checkbox"/> <input type="checkbox"/>
<input type="checkbox"/> Crystal Astral Pink (001 API)	<input type="checkbox"/> <input type="checkbox"/> <input type="checkbox"/>
<input type="checkbox"/> Crystal Golden Shadow (001 GSHA)	<input type="checkbox"/> <input type="checkbox"/> <input type="checkbox"/>
<input type="checkbox"/> Crystal Lilac Shadow (001 LISH)	<input type="checkbox"/> <input type="checkbox"/> <input type="checkbox"/>
<input type="checkbox"/> Crystal Silver Shade (001 SSHA)	<input type="checkbox"/> <input type="checkbox"/> <input type="checkbox"/>

6690 Wing Pendant

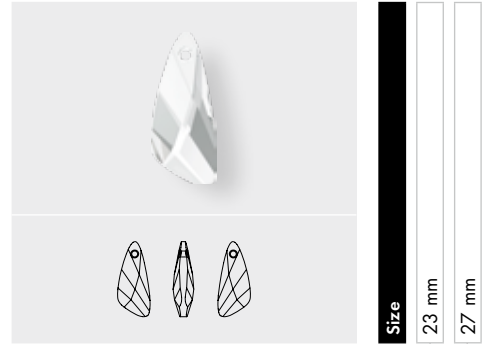

Crystal	
<input type="checkbox"/> Crystal (001)	<input type="checkbox"/> <input type="checkbox"/>
Colors	
Plain Colors	
<input type="checkbox"/> Aquamarine (202)	<input type="checkbox"/> <input type="checkbox"/>
<input type="checkbox"/> Capri Blue (243)	<input type="checkbox"/> <input type="checkbox"/>
<input type="checkbox"/> Light Rose (223)	<input type="checkbox"/> <input type="checkbox"/>
<input type="checkbox"/> Tanzanite (539)	<input type="checkbox"/> <input type="checkbox"/>
Crystal Effects	
Transparent Effects	
<input type="checkbox"/> Crystal AB (001 AB)	<input type="checkbox"/> <input type="checkbox"/>
<input type="checkbox"/> Crystal Astral Pink (001 API)	<input type="checkbox"/> <input type="checkbox"/>
<input type="checkbox"/> Crystal Golden Shadow (001 GSHA)	<input type="checkbox"/> <input type="checkbox"/>
<input type="checkbox"/> Crystal Silver Night (001 SINI)	<input type="checkbox"/> <input type="checkbox"/>

Pendants

6696 Urban Pendant

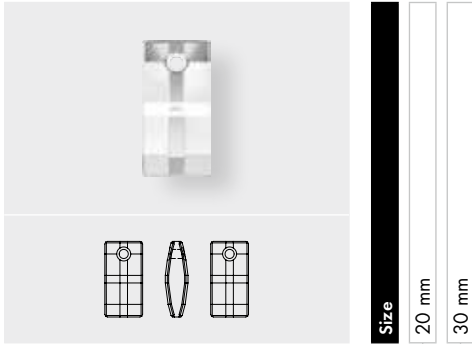

Crystal	
Crystal (001)	■ ■
Colors	
Plain Colors	
Denim Blue (266)	■ ■
Jet (280)	■ ■
Crystal Effects	
Transparent Effects	
Crystal AB (001 AB)	■ ■
Crystal Antique Pink (001 ANTP)	■ ■
Crystal Astral Pink (001 API)	■ ■
Crystal Bermuda Blue P (001 BBL)*	■ ■
Crystal Blue Shade (001 BLSH)	■ ■
Crystal Bronze Shade (001 BRSH)	■ ■
Crystal Golden Shadow (001 GSHA)	■ ■
Crystal Lilac Shadow (001 LISH)	■ ■
Crystal Silver Night (001 SINI)	■ ■
Crystal Silver Shade (001 SSHA)	■ ■
Crystal Tabac P (001 TAB)*	■ ■
Metallic Effects	
Crystal Comet Argent Light V P (001 CAL V)*	■ ■
Crystal Iridescent Green (001 IRIG)	■ ■
Color Effects	
Metallic Effects	
Jet Hematite (280 HEM)	■ ■

6704 Snowflake Pendant

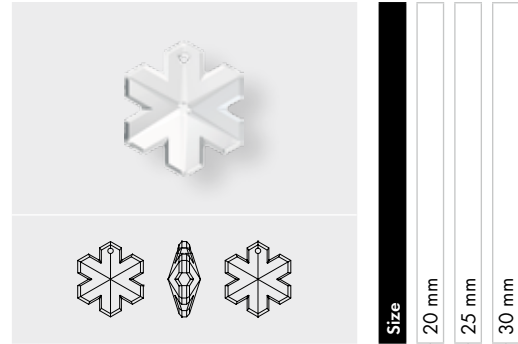

Crystal	
Crystal (001)	■ ■ ■
Crystal Effects	
Transparent Effects	
Crystal AB (001 AB)	■ ■ ■
Crystal Blue Shade (001 BLSH)	■ ■ ■

* For details about the „protective layer“ please refer to page 24.

Pendants

6714 Star Pendant

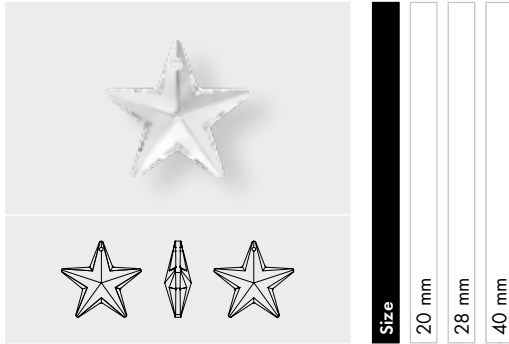

Crystal	20 mm	28 mm	40 mm
Crystal (001)	■	■	■
Colors			
Plain Colors			
Jet (280)	■		
Crystal Effects			
Transparent Effects			
Crystal AB (001 AB)	■	■	■
Crystal Astral Pink (001 API)	■	■	■
Crystal Blue Shade (001 BLSH)	■	■	■

6721 Starfish Pendant

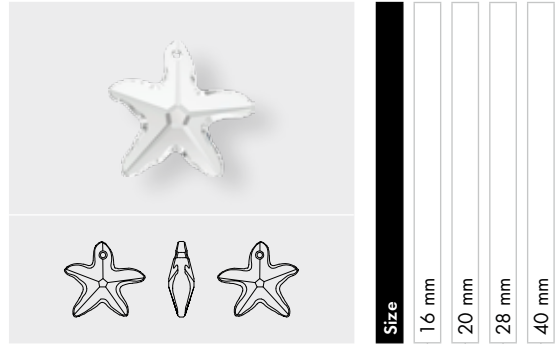

Crystal	16 mm	20 mm	28 mm	40 mm
Crystal (001)	■	■	■	■
Colors				
Plain Colors				
Aquamarine (202)	■	■		
Indicolite (379)	■	■		
Crystal Effects				
Transparent Effects				
Crystal AB (001 AB)	■	■	■	■
Crystal Astral Pink (001 API)	■	■	■	■
Crystal Bermuda Blue P (001 BBL)*	■	■	■	■
Crystal Blue Shade (001 BLSH)	■	■	■	■
Crystal Golden Shadow (001 GSHA)	■	■	■	■

6722 Moon Pendant

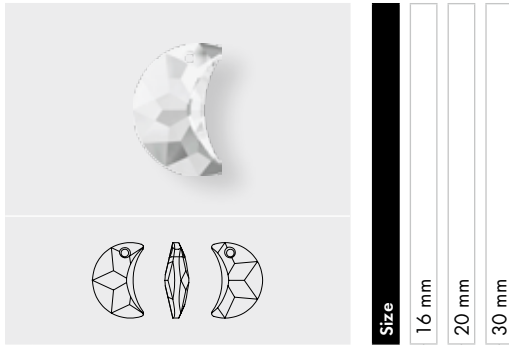

Crystal	16 mm	20 mm	30 mm
Crystal (001)	■	■	■
Crystal Effects			
Transparent Effects			
Crystal AB (001 AB)	■	■	■

* For details about the „protective layer“ please refer to page 24.

Pendants

6723 Shell Pendant

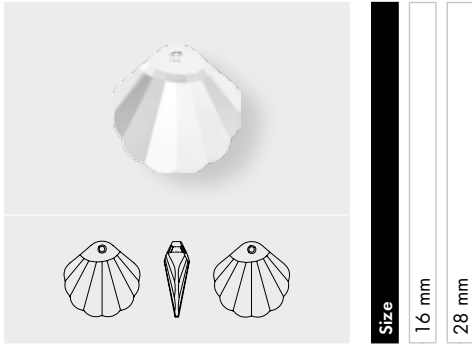

Size

16 mm

28 mm

- Crystal**
- Crystal (001)
- Colors**
- Plain Colors
- Aquamarine (202)
- Crystal Effects**
- Transparent Effects
- Crystal AB (001 AB)
- Crystal Golden Shadow (001 GSHA)

6727 Fish Pendant

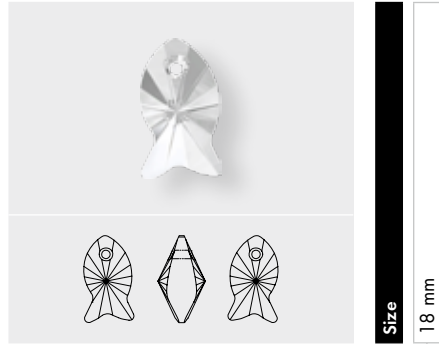

Size

18 mm

- Crystal**
- Crystal (001)
- Colors**
- Plain Colors
- Aquamarine (202)
- Crystal Effects**
- Transparent Effects
- Crystal AB (001 AB)
- Crystal Golden Shadow (001 GSHA)

Pendants

6734 Pure Leaf Pendant

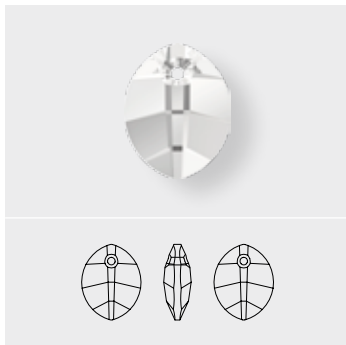

Size 14 mm

6734 Pure Leaf Pendant

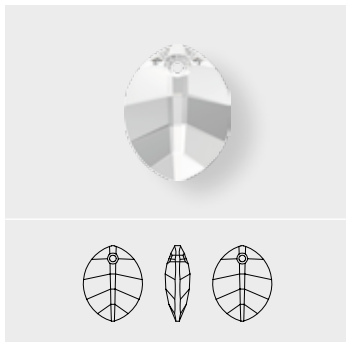

Size 23 mm

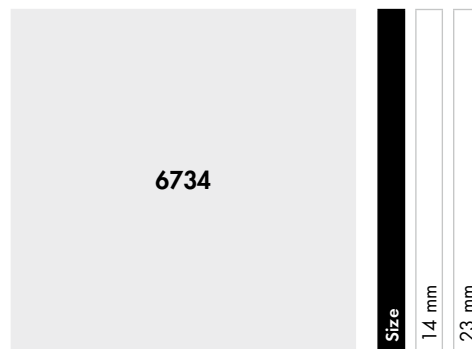

Crystal	
<input type="checkbox"/>	Crystal (001)
Colors	
Plain Colors	
<input type="checkbox"/>	Amethyst (204)
<input type="checkbox"/>	Dark Moss Green (260)
<input type="checkbox"/>	Fern Green (291)
<input type="checkbox"/>	Jet (280)
<input type="checkbox"/>	Peridot (214)
Crystal Effects	
Transparent Effects	
<input type="checkbox"/>	Crystal AB (001 AB)
<input type="checkbox"/>	Crystal Blue Shade (001 BLSH)
<input type="checkbox"/>	Crystal Golden Shadow (001 GSHA)
<input type="checkbox"/>	Crystal Luminous Green (001 LUMG)
<input type="checkbox"/>	Crystal Red Magma (001 REDM)
<input type="checkbox"/>	Crystal Silver Night (001 SINI)
Metallic Effects	
<input type="checkbox"/>	Crystal Iridescent Green (001 IRIG)

Pendants

6735 Leaf Pendant

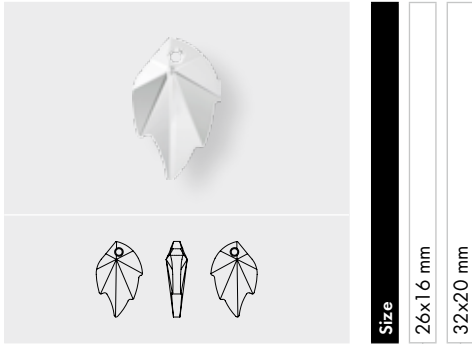

Size

26x16 mm

32x20 mm

Crystal

Crystal (001)

Crystal Effects

Transparent Effects

Crystal AB (001 AB)

Crystal Golden Shadow (001 GSHA)

6744 Flower Pendant

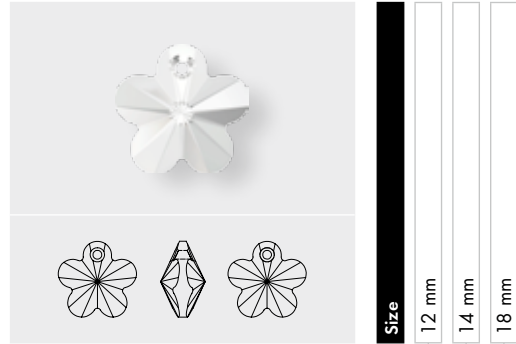

Size

12 mm

14 mm

18 mm

Crystal

Crystal (001)

Colors

Plain Colors

Aquamarine (202)

Fuchsia (502)

Light Rose (223)

Violet (371)

Crystal Effects

Transparent Effects

Crystal AB (001 AB)

Crystal Blue Shade (001 BLSH)

Crystal Golden Shadow (001 GSHA)

6754 Butterfly Pendant

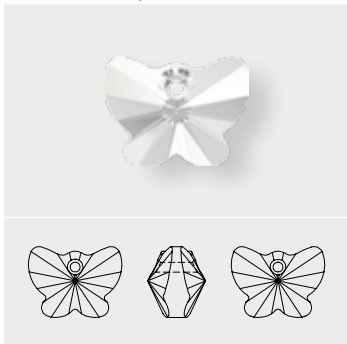

Size

18 mm

Crystal

Crystal (001)

Colors

Plain Colors

Amethyst (204)

Aquamarine (202)

Fuchsia (502)

Light Rose (223)

Violet (371)

Crystal Effects

Transparent Effects

Crystal Astral Pink (001 API)

Crystal Golden Shadow (001 GSHA)

Crystal Moonlight (001 MOL)

Pendants

6764 Clover Pendant

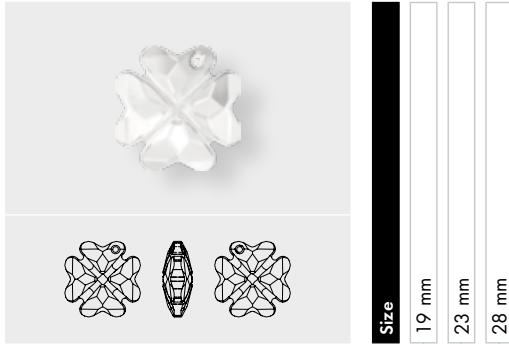

Size
19 mm
23 mm
28 mm

Crystal

Crystal (001)

Colors

Plain Colors

Dark Moss Green (260)
Emerald (205)
Fuchsia (502)
Jet (280)
Light Rose (223)
Peridot (214)

Crystal Effects

Transparent Effects

Crystal AB (001 AB)
Crystal Antique Pink (001 ANTP)
Crystal Astral Pink (001 API)
Crystal Blue Shade (001 BLSH)
Crystal Golden Shadow (001 GSHA)
Crystal Luminous Green (001 LUMG)
Crystal Red Magma (001 REDM)
Crystal Silver Night (001 SINI)
Crystal Silver Shade (001 SSHA)

Metallic Effects

Crystal Iridescent Green (001 IRIG)

6860

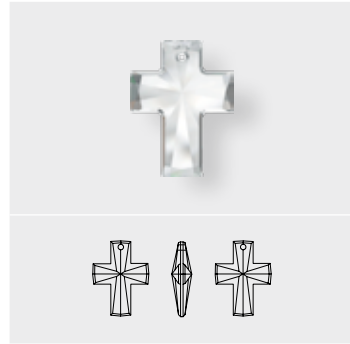

Size
12x10 mm
20x16 mm

Crystal

Crystal (001)

6864

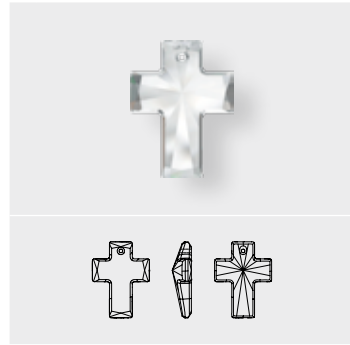

Size
40x30 mm

Crystal

Crystal (001)

Crystal Effects

Transparent Effects

Crystal AB V (001 AB V)

Pendants

6866



Size

20 mm

Crystal

Crystal (001)

Crystal Effects

Transparent Effects

Crystal AB (001 AB)

Crystal Astral Pink (001 API)

Crystal Golden Shadow (001 GSHA)

Crystal Heliotrope (001 HEL)

6918 Key to Open the Forest*

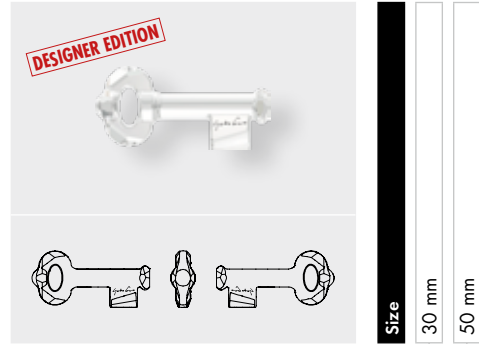

Size

30 mm

50 mm

Crystal

Crystal (001)

Colors

Plain Colors

Indian Sapphire (217)

Crystal Effects

Transparent Effects

Crystal Blue Shade (001 BLSH)

Crystal Bronze Shade (001 BRSH)

Crystal Copper (001 COP)

Crystal Golden Shadow (001 GSHA)

Crystal Silver Night (001 SINI)

Crystal Silver Shade (001 SSHA)

6919 Key Pendant

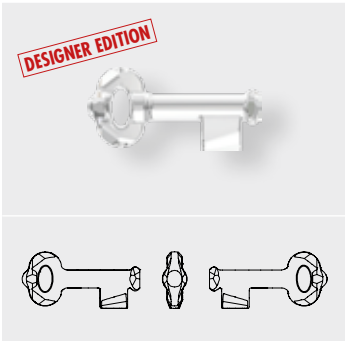

Size

30 mm

50 mm

Crystal

Crystal (001)

Colors

Plain Colors

Indian Sapphire (217)

Crystal Effects

Transparent Effects

Crystal AB (001 AB)

Crystal Blue Shade (001 BLSH)

Crystal Bronze Shade (001 BRSH)

Crystal Copper (001 COP)

Crystal Golden Shadow (001 GSHA)

Crystal Silver Night (001 SINI)

Crystal Silver Shade (001 SSHA)

Metallic Effects

Crystal Iridescent Green (001 IRIG)

* Please note, that this article is only available until August 2015.

Pendants

PRODUCT DETAILS

Article Size	Packing Unit = Minimum Order Quantity in Pieces	Average Net Weight in Gram per Packing Unit Crystal (001)	Average Gross Weight in Gram per Packing Unit Crystal (001)
6000			
11x5.5 mm	288	99.8	123.1
13x6.5 mm	288	156.9	197.5
15x7.5 mm	144	129.8	153.4
22x11 mm	48	129.4	151.3
28x14 mm	24	132.2	156.1
6002			
10x7 mm	144	91.4	109.3
15x11.5 mm	72	175.4	197.3
6007			
7x4 mm	360	46.7	55.8
9x5 mm	288	77.1	104.2
6010			
11x5.5 mm	144	57.4	75.9
13x6.5 mm	144	91.1	109.0
17x8.5 mm	36	57.3	77.2
21x10.5 mm	24	66.3	83.4
50x21.5 mm	6	173.71	222.77
6012			
11x10 mm	144	94.2	120.0
15.4x14 mm	72	126.0	157.3
6015			
17 mm	72	93.2	111.5
21 mm	48	105.9	129.3
50 mm	6	173.7	222.8
6016/G			
30 mm	12	20.160	45.612
56 mm	6	67.536	91.392
6017/G			
30 mm	12	24.968	45.612
56 mm	6	67.536	91.392
6018/G			
35 mm	8	52.416	74.592
6019/G			
35 mm	8	52.416	74.592
6020			
18 mm	36	49.69	72.12
30 mm	12	74.33	95.53
37 mm	6	76.38	82.46
6022			
14 mm	72	77.172	97.030
24 mm	24	133.923	155.460
33 mm	8	111.599	139.025
6026			
13 mm	144	111.888	132.209
20 mm	48	131.040	151.885
27 mm	20	116.088	136.970
6028			
8 mm	144	31.780	40.927
10 mm	192	70.963	97.736
12 mm	108	68.947	92.897
18 mm	72	146.543	170.251

Pendants

Article Size	Packing Unit = Minimum Order Quantity in Pieces	Average Net Weight in Gram per Packing Unit Crystal (001)	Average Gross Weight in Gram per Packing Unit Crystal (001)
6039			
25 mm	24	88.4	117.5
38 mm	9	92.7	123.8
6040			
20 mm	72	66.29	92.79
30 mm	30	85.37	116.36
40 mm	6	41.68	61.38
6041			
18 mm	30	38.304	63.101
28 mm	12	57.859	80.237
38 mm	6	65.318	88.286
6049			
20 mm	72	170.5	200.4
30 mm	24	166.7	209.2
6090			
16x11 mm	72	55.8	75.8
22x15 mm	48	102.2	136.7
6100			
24x12 mm	36	54.5	83.9
6106			
16 mm	144	129.9	158.3
22 mm	96	208.1	248.5
28 mm	36	171.8	201.1
38 mm	9	91.1	121.6
50 mm	6	146.1	177.9
6110			
30x14 mm	36	147.6	178.8
40x18 mm	12	132.6	159.2
6128			
8 mm	144	23.21	34.07
10 mm	144	52.30	80.00
12 mm	144	81.82	101.28
6150			
30 mm	48	140.6	174.5
50 mm	9	109.2	140.7
6210			
12 mm	144	67.8	90.9
17 mm	72	98.8	122.0
6215			
18 mm	72	183.2	210.5
6225			
10 mm	144	48.3	68.4
18 mm	24	41.6	59.0
28 mm	24	160.7	206.2
6228			
10.3x10 mm	288	124.6	152.6
14.4x14 mm	144	181.4	210.5
18x17.5 mm	72	188.0	211.7
28 mm	16	124.0	158.7
40 mm	6	137.9	169.2

Pendants

Article Size	Packing Unit = Minimum Order Quantity in Pieces	Average Net Weight in Gram per Packing Unit Crystal (001)	Average Gross Weight in Gram per Packing Unit Crystal (001)
6240			
12 mm	108	63.28	83.47
17 mm	72	116.43	137.02
27 mm	24	142.56	147.84
37 mm	6	80.85	109.25
6260			
17 mm	48	56.25	81.93
27 mm	20	88.72	111.92
37 mm	6	60.26	88.96
6261			
17 mm	48	48.21	76.63
27 mm	20	77.00	102.60
36 mm	12	112.49	135.29
6262			
17 mm	48	67.90	91.90
26 mm	16	74.02	92.48
34 mm	6	53.74	80.33
6264			
18 mm	48	93.41	109.11
28 mm	16	93.74	118.24
36 mm	6	80.35	108.15
6320			
14 mm	96	48.21	70.00
19 mm	48	61.59	78.29
27 mm	24	89.07	101.26
6328			
6 mm	360	78.51	89.50
8 mm	288	153.21	173.20
10 mm	144	144.40	165.0
6401			
8 mm	288	106.8	123.8
12 mm	144	164.9	182.7
6428			
6 mm	720	80.1	89.5
8 mm	144	37.4	46.7
12 mm	144	121.8	141.6
6460			
20 mm	72	60.3	83.1
6470			
32 mm	36	82.47	100.26
40 mm	18	84.07	114.36
48 mm	12	95.69	128.49
6480			
18 mm	48	42.74	64.08
28 mm	36	101.61	130.50
39 mm	16	105.64	133.69
6621			
18 mm	72	192.8	212.7
28 mm	24	190.8	217.8

Pendants

07 Pendants

Article Size	Packing Unit = Minimum Order Quantity in Pieces	Average Net Weight in Gram per Packing Unit Crystal (001)	Average Gross Weight in Gram per Packing Unit Crystal (001)
6628			
8 mm	288	72.565	72.759
12 mm	144	101.606	126.887
16 mm	72	128.218	155.131
6650			
22 mm	24	101.5	119.7
6656			
19 mm	48	72.3	94.2
27 mm	30	126.1	159.6
39 mm	6	61.8	82.0
6670			
18 mm	72	68.4	104.6
24 mm	48	105.5	161.9
50 mm	6	104.7	126.8
6673			
18 mm	48	59.674	80.721
28 mm	20	89.040	112.241
38 mm	6	69.466	87.142
6680			
14 mm	144	118.7	145.1
20 mm	72	167.5	191.1
40 mm	12	146.3	171.9
6685			
19 mm	48	104.46	127.35
28 mm	24	168.74	175.44
38 mm	6	105.46	121.16
6690			
23 mm	36	54.5	88.6
27 mm	36	99.4	130.5
6696			
20 mm	24	53.505	70.641
30 mm	10	59.640	83.328
6704			
20 mm	48	131.4	155.0
25 mm	24	115.8	160.7
30 mm	16	128.1	164.1
6714			
20 mm	48	48.2	73.1
28 mm	24	112.5	156.1
40 mm	6	56.1	87.4
6721			
16 mm	72	105.1	131.7
20 mm	30	76.8	113.6
28 mm	12	66.3	93.7
40 mm	6	83.9	113.5
6722			
16 mm	72	63.9	87.2
20 mm	48	64.3	102.4
30 mm	20	113.8	131.3

Pendants

Article Size	Packing Unit = Minimum Order Quantity in Pieces	Average Net Weight in Gram per Packing Unit Crystal (001)	Average Gross Weight in Gram per Packing Unit Crystal (001)
6723			
16 mm	96	176.8	215.0
28 mm	18	126.6	160.3
6727			
18 mm	72	168.7	190.1
6734			
14 mm	108	82.555	104.237
23 mm	30	88.452	111.611
6735			
26x16 mm	30	73.3	110.0
32x20 mm	30	136.7	175.6
6744			
12 mm	144	118.7	145.4
14 mm	144	172.9	204.5
18 mm	72	174.8	207.2
6754			
18 mm	72	217.0	248.3
6764			
19 mm	48	114.509	131.806
23 mm	24	95.760	138.419
28 mm	16	110.208	128.782
6860			
12x10 mm	144	31.2	54.5
20x16 mm	72	48.2	73.1
6864			
40x30 mm	9	109.2	142.2
6866			
20 mm	72	249.5	272.8
6918			
30 mm	36	63.806	88.633
50 mm	6	43.596	66.493
6919			
30 mm	36	63.806	88.633
50 mm	6	43.596	66.493

Flat Backs No Hotfix

Flat Backs No Hotfix are loose crystal elements backed with platinum foiling for extra brilliance and protection. These Flat Backs are easy to apply to a variety of carrier materials using standard one- or two-component glues. They are available in a multitude of sizes, colors, shapes and cuts.

The most innovative single item in this product group is art. 2088 XIRIUS Rose, with its most progressive and unique cut in the market: multilayer cut technology creates the inspiring XIRIUS star design. Superior fire and a rich, well balanced cloud of light points redefine the market standard.

Swarovski's outstanding quality standards of crystal elements are underlined by highest precision in table size and diameter.

COLORS & EFFECTS

Colors



Crystal
001



White Opal
234



Light Silk
261



Silk
391



Light Peach
362



Vintage Rose
319



Light Rose
223



Rose Peach
262



Padparadscha
542



Indian Pink
289



Sun
248



Fireopal*
237



Hyacinth
236



Light Siam
227



Indian Siam*
327



Rose
209



Fuchsia
502



Ruby
501



Siam
208



Burgundy
515



Amethyst
204



Cyclamen Opal
398



Purple Velvet
277



Cobalt
369



Tanzanite
539



Light Amethyst
212



Provence Lavender
283



Light Sapphire
211



Aquamarine
202



Air Blue Opal
285



Sapphire
206



Capri Blue
243



Dark Indigo
288



Montana
207



Caribbean Blue Opal
394



Light Turquoise
263



Blue Zircon
229



Denim Blue
266



Black Diamond
215



Pacific Opal
390



Chrysolite Opal
294



Chrysolite
238



Peridot
214



Erinite
360



Fern Green
291



Dark Moss Green
260



Emerald
205



Olivine
228



Khaki
550



Greige
284



Light Colorado Topaz
246



Jonquil
213



Citrine
249



Light Topaz
226



Sunflower
292



Topaz
203



Tangerine
259



Smoked Topaz
220



Mocca
286



Jet**
280

Ceramics



Marbled Light Grey
657



Marbled Terracotta
655



Marbled Yellow
652



Marbled Blue
654



Marbled Black
653

Effects



Crystal Silver Shade
001 SSHA



Crystal Moonlight
001 MOL



Crystal Aurore Boreale
001 AB



Crystal Luminous Green***
001 LUMG



Crystal Golden Shadow
001 GSHA



Crystal Rose Gold
001 ROGL



Crystal Copper***
001 COP



Crystal Astral Pink
001 API



Light Siam Aurore Boreale
227 AB



Crystal Red Magma***
001 REDM



Light Rose Aurore Boreale
223 AB



Crystal Antique Pink
001 ANTP



Rose Aurore Boreale
209 AB



Crystal Volcano
001 VOL



Crystal Lilac Shadow
001 LISH



Sapphire Aurore Boreale
206 AB



Crystal Metallic Blue***
001 METBL



Crystal Meridian Blue
001 MBL



Aquamarine Aurore Boreale
202 AB



Crystal Blue Shade
001 BLSH



Peridot Aurore Boreale
214 AB



Jonquil Aurore Boreale
213 AB



Crystal Iridescent Green
001 IRIG



Crystal Dorado***
001 DOR



Crystal Metallic Light Gold***
001 MLGID



Crystal Bronze Shade***
001 BRSH



Topaz Aurore Boreale
203 AB



Crystal Silver Night
001 SINI



Jet Nut***
280 NUT



Crystal Cosmojet*
001 COS



Jet Hematite**/**
280 HEM

Numerical Order

001	Crystal	203	Topaz	229	Blue Zircon	289	Indian Pink
001 AB	Crystal Aurore Boreale	203 AB	Topaz Aurore Boreale	234	White Opal	291	<u>Fern Green</u>
001 ANTP	<u>Crystal Antique Pink</u>	204	Amethyst	236	Hyacinth	292	<u>Sunflower</u>
001 API	<u>Crystal Astral Pink</u>	205	Emerald	237	<u>Fireopal*</u>	294	<u>Chrysolite Opal</u>
001 BLSH	<u>Crystal Blue Shade</u>	206	Sapphire	238	Chrysolite	319	<u>Vintage Rose</u>
001 BRSH	<u>Crystal Bronze Shade***</u>	206 AB	Sapphire Aurore Boreale	243	Capri Blue	327	<u>Indian Siam*</u>
001 COP	<u>Crystal Copper***</u>	207	Montana	246	Light Colorado Topaz	360	<u>Erinite</u>
001 COS	<u>Crystal Cosmojet*</u>	208	Siam	248	Sun	362	Light Peach
001 DOR	<u>Crystal Dorado***</u>	209	Rose	249	Citrine	369	Cobalt
001 GSHA	<u>Crystal Golden Shadow</u>	209 AB	Rose Aurore Boreale	259	<u>Tangerine</u>	390	<u>Pacific Opal</u>
001 IRIG	<u>Crystal Iridescent Green</u>	211	Light Sapphire	260	<u>Dark Moss Green</u>	391	Silk
001 LISH	<u>Crystal Lilac Shadow</u>	212	Light Amethyst	261	<u>Light Silk</u>	394	<u>Caribbean Blue Opal</u>
001 LUMG	<u>Crystal Luminous Green***</u>	213	Jonquil	262	<u>Rose Peach</u>	398	<u>Cyclamen Opal</u>
001 MBL	<u>Crystal Meridian Blue</u>	213 AB	Jonquil Aurore Boreale	263	Light Turquoise	501	Ruby
001 METBL	<u>Crystal Metallic Blue***</u>	214	Peridot	266	<u>Denim Blue</u>	502	Fuchsia
001 MLGLD	<u>Crystal Metallic Light Gold***</u>	214 AB	Peridot Aurore Boreale	277	Purple Velvet	515	Burgundy
001 MOL	Crystal Moonlight	215	Black Diamond	280	Jet**	539	Tanzanite
001 REDM	<u>Crystal Red Magma***</u>	220	Smoked Topaz	280 HEM	Jet Hematite**/**	542	<u>Padparadscha</u>
001 ROGL	<u>Crystal Rose Gold</u>	223	Light Rose	280 NUT	Jet Nut***	550	Khaki
001 SINI	<u>Crystal Silver Night</u>	223 AB	Light Rose Aurore Boreale	283	Provence Lavender	652	<u>Marbled Yellow</u>
001 SSHA	<u>Crystal Silver Shade</u>	226	Light Topaz	284	<u>Greige</u>	653	<u>Marbled Black</u>
001 VOL	Crystal Volcano	227	Light Siam	285	<u>Air Blue Opal</u>	654	<u>Marbled Blue</u>
202	Aquamarine	227 AB	Light Siam Aurore Boreale	286	<u>Mocca</u>	655	<u>Marbled Terracotta</u>
202 AB	Aquamarine Aurore Boreale	228	Olivine	288	<u>Dark Indigo</u>	657	<u>Marbled Light Grey</u>

Alphabetical Order

<u>Air Blue Opal (285)</u>	<u>Crystal Lilac Shadow (001 LISH)</u>	Jet (280)**	Olivine (228)
Amethyst (204)	<u>Crystal Luminous Green (001 LUMG)***</u>	Jet Hematite (280 HEM)**/**	<u>Pacific Opal (390)</u>
Aquamarine (202)	<u>Crystal Meridian Blue (001 MBL)</u>	Jet Nut (280 NUT)**	<u>Padparadscha (542)</u>
Aquamarine Aurore Boreale (202 AB)	<u>Crystal Metallic Blue (001 METBL)***</u>	Jonquil (213)	Peridot (214)
Black Diamond (215)	<u>Crystal Metallic Light Gold (001 MLGLD)***</u>	Jonquil Aurore Boreale (213 AB)	Peridot Aurore Boreale (214 AB)
Blue Zircon (229)	<u>Crystal Moonlight (001 MOL)</u>	Khaki (550)	Provence Lavender (283)
Burgundy (515)	<u>Crystal Red Magma (001 REDM)***</u>	Light Amethyst (212)	Purple Velvet (277)
Capri Blue (243)	<u>Crystal Rose Gold (001 ROGL)</u>	Light Colorado Topaz (246)	Rose (209)
<u>Caribbean Blue Opal (394)</u>	<u>Crystal Silver Night (001 SINI)</u>	Light Peach (362)	Rose Aurore Boreale (209 AB)
Chrysolite (238)	<u>Crystal Silver Shade (001 SSHA)</u>	Light Rose (223)	<u>Rose Peach (262)</u>
<u>Chrysolite Opal (294)</u>	<u>Crystal Volcano (001 VOL)</u>	Light Rose Aurore Boreale (223 AB)	Ruby (501)
Citrine (249)	<u>Cyclamen Opal (398)</u>	Light Sapphire (211)	Sapphire (206)
Cobalt (369)	<u>Dark Indigo (288)</u>	Light Siam (227)	Sapphire Aurore Boreale (206 AB)
Crystal (001)	<u>Dark Moss Green (260)</u>	Light Siam Aurore Boreale (227 AB)	Siam (208)
<u>Crystal Antique Pink (001 ANTP)</u>	<u>Denim Blue (266)</u>	<u>Light Silk (261)</u>	Silk (391)
<u>Crystal Astral Pink (001 API)</u>	Emerald (205)	Light Topaz (226)	Smoked Topaz (220)
Crystal Aurore Boreale (001 AB)	<u>Erinite (360)</u>	Light Turquoise (263)	Sun (248)
<u>Crystal Blue Shade (001 BLSH)</u>	<u>Fern Green (291)</u>	<u>Marbled Black (653)</u>	<u>Sunflower (292)</u>
<u>Crystal Bronze Shade (001 BRSH)***</u>	<u>Fireopal (237)*</u>	<u>Marbled Blue (654)</u>	<u>Tangerine (259)</u>
<u>Crystal Copper (001 COP)***</u>	Fuchsia (502)	<u>Marbled Light Grey (657)</u>	Tanzanite (539)
<u>Crystal Cosmojet (001 COS)*</u>	<u>Greige (284)</u>	<u>Marbled Terracotta (655)</u>	Topaz (203)
<u>Crystal Dorado (001 DOR)***</u>	Hyacinth (236)	<u>Marbled Yellow (652)</u>	Topaz Aurore Boreale (203 AB)
<u>Crystal Golden Shadow (001 GSHA)</u>	Indian Pink (289)	<u>Mocca (286)</u>	<u>Vintage Rose (319)</u>
<u>Crystal Iridescent Green (001 IRIG)</u>	<u>Indian Siam* (327)</u>	Montana (207)	White Opal (234)

This color chart is valid for the product group Flat Backs No Hotfix.

The displayed assortment is not entirely available for all products within the product group. For details on available colors and effects, please see the product matrix for the respective item.

Classic Colors: This color range offers a wide choice of traditional Swarovski crystal colors.
Exclusive Colors: This color range is offered exclusively by Swarovski.

The standard assortment of colors and effects may vary according to the product group.

Slight changes in shades are unavoidable. Colors may vary according to cut and shape.

















































* Only available in limited sizes.

** In these colors art. 2088 is available as foiled or unfoiled version.

***Crystals are not resistant to plating and similar processing.

Flat Backs No Hotfix

SUMMARY

1 	2 	2000 SS 3, 4	1 	2 	2483 10, 25 mm	1 	2 	2788 8, 10, 14 mm
		2006 10, 12, 14, 16 mm			2493 8, 10, 12, 20, 30 mm			2797 8x4, 10x5 mm
		2035 6, 10, 14, 20, 30, 40 mm			2520 8x6, 10x8, 14x10 mm			2808 6, 10, 14 mm
		2037 8, 14, 17 mm			2555 8x2.6, 12x4, 15x5 mm			2816 5 mm
		2058 SS 5, 6, 7, 8, 9, 10 mm			2570 50x16 mm			2826 5 mm
		2058/B SS 7, 9, 12, 16, 20			2585 8, 10, 14 mm			2854 8, 12, 18 mm
		2072 8, 10, 12 mm			2611 8, 10, 14 mm			2858 6x4.5, 9x6.5, 12x8.5 mm
		2088 SS 12, 14, 16, 20, 30, 34, 40, 48			2611/G 8, 10, 14 mm			
		2200 8x4 mm			2708 8x8.7, 12.5x13.6 mm			
		2204 6x4.8, 10x8, 14x11 mm			2709 10x6, 13x8 mm			
		2300 8x4.8, 10x6 mm			2716 5 mm			
		2400 3, 4, 6 mm			2720 7.5, 9, 12.5 mm			
		2420 10, 25 mm			2770 6x3.5, 12x7 mm			

1 Top view 2 Side view

• The logo position is marked with a red dot.

Flat Backs No Hotfix

2000 Rose Flat Back

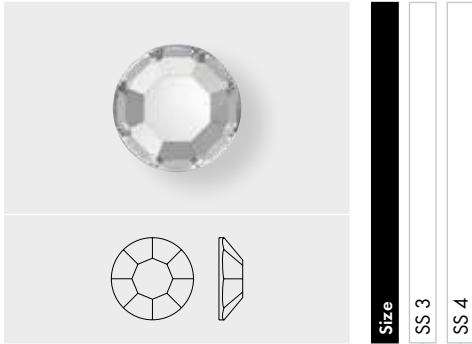

Size
SS 3
SS 4

Crystal	
Crystal F (001)	■ ■
Colors	
Plain Colors	
Amethyst F (204)	■
Aquamarine F (202)	■
Black Diamond F (215)	■
Indian Siam F (327)	■
Jet (280)	■
Jonquil F (213)	■
Light Colorado Topaz F (246)	■
Light Rose F (223)	■
Montana F (207)	■
Peridot F (214)	■
Smoked Topaz F (220)	■
Crystal Effects	
Transparent Effects	
Crystal AB F (001 AB)	■ ■
Crystal Golden Shadow F (001 GSHA)	■
Crystal Silver Shade F (001 SSHA)	■
Metallic Effects	
Crystal Metallic Blue F (001 METBL)	■
Crystal Metallic Light Gold F (001 MLGLD)	■
Crystal Rose Gold F (001 ROGL)	■
Color Effects	
Metallic Effects	
Jet Hematite (280 HEM)	■

2006 Rivoli Flat Back

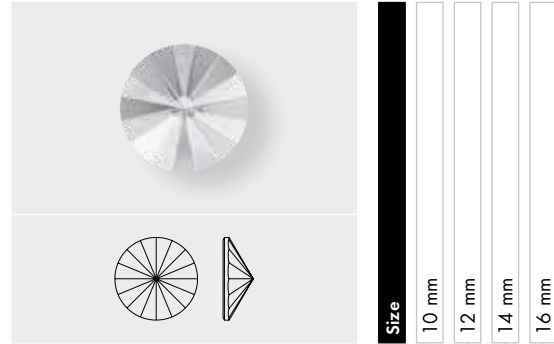

Size
10 mm
12 mm
14 mm
16 mm

Crystal	
Crystal F (001)	■ ■ ■ ■

Flat Backs No Hotfix

2035 Chessboard Circle Flat Back

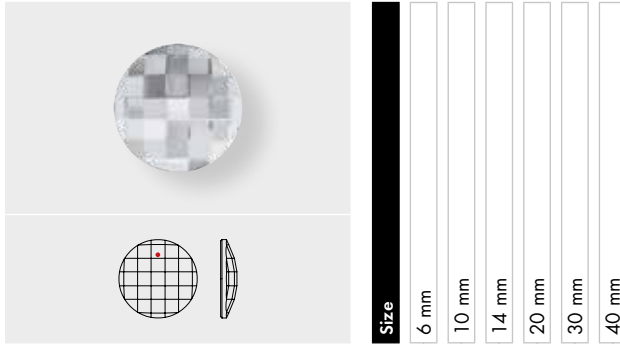

	6 mm	10 mm	14 mm	20 mm	30 mm	40 mm
Crystal						
Crystal F (001)	■	■	■	■	■	■
Crystal CAL SI (001 CAL SI) ¹⁾⁺²⁾				■		
Crystal CAL V SI (001 CAL V SI) ¹⁾				■	■	■
Colors						
Plain Colors						
Aquamarine F (202)	■	■	■			
Black Diamond F (215)	■	■	■	■		
Jet (280)	■	■	■	■		
Crystal Effects						
Transparent Effects						
Crystal AB F (001 AB)	■	■				
Crystal Antique Pink F (001 ANTP)	■	■				
Crystal Golden Shadow F (001 GSHA)	■	■	■	■		
Crystal Red Magma F (001 REDM)	■	■	■			

2037 Eclipse Flat Back

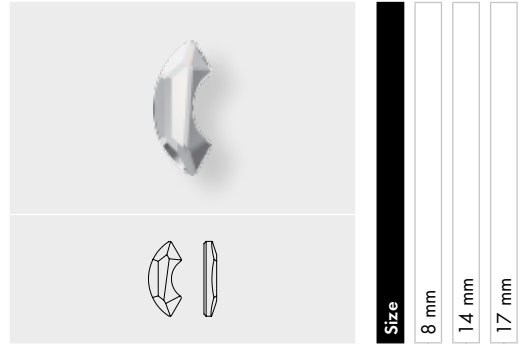

	8 mm	14 mm	17 mm
Crystal			
Crystal F (001)	■	■	■

¹⁾ Integrated articles of the former Bath & Wellness Collection may be partly delivered with a laser-engraved logo.

● The logo position is marked with a red dot.

²⁾ Coated on faceted side.

Flat Backs No Hotfix

2058 XILION Rose Enhanced

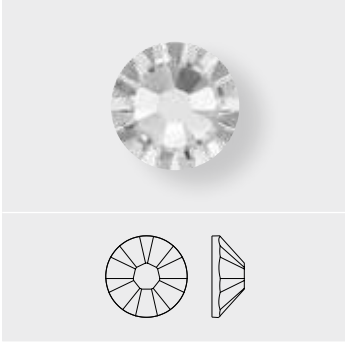

Size	SS 5	SS 6	SS 7	SS 8	SS 9	SS 10
------	------	------	------	------	------	-------

Crystal

Crystal F (001)	■	■	■	■	■	■
-----------------	---	---	---	---	---	---

Colors

Plain Colors

Amethyst F (204)	■	■	■		■	■
Aquamarine F (202)	■	■	■		■	■
Black Diamond F (215)	■	■	■	■	■	■
Blue Zircon F (229)	■	■	■		■	■
Burgundy F (515)	■		■		■	
Capri Blue F (243)	■	■	■		■	■
Chrysolite F (238)	■		■		■	
Citrine F (249)	■	■	■		■	■
Cobalt F (369)	■		■		■	
Dark Indigo F (288)	■		■		■	
Dark Moss Green F (260)	■		■		■	
Denim Blue F (266)	■		■		■	
Emerald F (205)	■	■	■		■	■
Erinite F (360)	■		■		■	
Fern Green F (291)	■		■		■	
Fuchsia F (502)	■	■	■		■	■
Greige F (284)	■		■		■	
Hyacinth F (236)	■	■	■		■	■
Indian Pink F (289)	■		■		■	
Indian Siam F (327)	■		■		■	
Jet (280)	■	■	■	■	■	■
Jet F (280)	■	■	■	■	■	■
Jonquil F (213)	■	■	■		■	■
Light Amethyst F (212)	■	■	■		■	■
Light Colorado Topaz F (246)	■	■	■	■	■	■
Light Peach F (362)	■		■		■	
Light Rose F (223)	■	■	■	■	■	■
Light Sapphire F (211)	■	■	■		■	■
Light Siam F (227)	■	■	■	■	■	■
Light Silk F (261)	■		■		■	
Light Topaz F (226)	■		■		■	
Light Turquoise F (263)	■		■		■	
Mocca F (286)	■		■		■	
Montana F (207)	■	■	■		■	■
Olivine F (228)	■		■		■	
Padparadscha F (542)	■		■		■	
Peridot F (214)	■	■	■		■	■

08 Flat Backs No Hotfix

Flat Backs No Hotfix

2058		Size	SS 5	SS 6	SS 7	SS 8	SS 9	SS 10
Provence Lavender F (283)			■		■		■	
Purple Velvet F (277)			■		■		■	
Rose F (209)			■	■	■	■	■	■
Rose Peach F (262)			■				■	
Ruby F (501)			■	■	■		■	■
Sapphire F (206)			■	■	■		■	■
Siam F (208)			■	■	■		■	■
Silk F (391)			■		■		■	
Smoked Topaz F (220)			■	■	■		■	■
Sun F (248)			■	■	■		■	■
Sunflower F (292)			■		■		■	
Tangerine F (259)			■		■		■	
Tanzanite F (539)			■	■	■		■	■
Topaz F (203)			■	■	■		■	■
Vintage Rose F (319)			■		■		■	
Opal Colors								
Air Blue Opal F (285)			■		■		■	
Caribbean Blue Opal F (394)			■		■		■	
Chrysolite Opal F (294)			■		■		■	
Cyclamen Opal F (398)			■		■		■	
Pacific Opal F (390)			■		■		■	
White Opal F (234)			■		■		■	
Crystal Effects								
Transparent Effects								
Crystal AB F (001 AB)			■	■	■	■	■	■
Crystal Antique Pink F (001 ANTP)			■		■		■	
Crystal Blue Shade F (001 BLSH)			■		■		■	
Crystal Bronze Shade F (001 BRSH)			■		■		■	
Crystal Copper F (001 COP)			■		■		■	
Crystal Cosmojet F (001 COS)			■		■		■	
Crystal Golden Shadow F (001 GSHA)			■		■		■	
Crystal Lilac Shadow F (001 LISH)			■		■		■	
Crystal Luminous Green F (001 LUMG)			■		■		■	
Crystal Meridian Blue F (001 MBL)			■		■		■	
Crystal Moonlight F (001 MOL)			■		■		■	
Crystal Red Magma F (001 REDM)			■		■		■	
Crystal Silver Night F (001 SINI)			■		■		■	
Crystal Silver Shade F (001 SSHA)			■		■		■	
Crystal Volcano F (001 VOL)			■	■	■		■	■
Metallic Effects								
Crystal Dorado F (001 DOR)			■		■		■	

Flat Backs No Hotfix

08 Flat Backs No Hotfix

2058		Size	SS 5	SS 6	SS 7	SS 8	SS 9	SS 10
	Crystal Iridescent Green F (001 IRIG)		■		■		■	
	Crystal Metallic Blue F (001 METBL)		■		■		■	
	Crystal Metallic Light Gold F (001 MLGLD)		■		■		■	
	Crystal Rose Gold F (001 ROGL)		■		■		■	
Color Effects								
Transparent Effects								
	Aquamarine AB F (202 AB)		■		■		■	
	Jonquil AB F (213 AB)		■		■		■	
	Light Rose AB F (223 AB)		■		■		■	
	Light Siam AB F (227 AB)		■		■		■	
	Peridot AB F (214 AB)		■		■		■	
	Rose AB F (209 AB)		■		■		■	
	Sapphire AB F (206 AB)		■		■		■	
	Topaz AB F (203 AB)		■		■		■	
Metallic Effects								
	Jet Hematite (280 HEM)		■	■	■		■	■
	Jet Hematite F (280 HEM)		■	■	■		■	■
	Jet Nut F (280 NUT)		■		■		■	

2058/B XILION Rose Flat Back

2058/B XILION Rose Flat Back		Size	SS 7	SS 9	SS 12	SS 16	SS 20
	Marbled Black (653)		■	■	■	■	■
	Marbled Blue (654)		■	■	■	■	■
	Marbled Light Grey (657)		■	■	■	■	■
	Marbled Terracotta (655)		■	■	■	■	■
	Marbled Yellow (652)		■	■	■	■	■

2072 Rose Cut Flat Back

2072 Rose Cut Flat Back		Size	8 mm	10 mm	12 mm
	Crystal F (001)		■	■	■
Colors					
Plain Colors					
	Jet (280)		■	■	

Flat Backs No Hotfix

2088 XIRIUS Rose

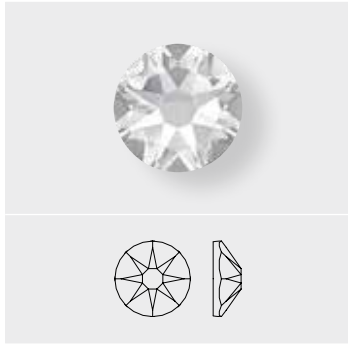

	SS 12	SS 14	SS 16	SS 20	SS 30	SS 34	SS 40	SS 48
Crystal								
Crystal F (001)	■	■	■	■	■	■	■	■
Colors								
Plain Colors								
Amethyst F (204)	■		■	■	■	■		
Aquamarine F (202)	■		■	■	■	■		
Black Diamond F (215)	■	■		■	■	■		
Blue Zircon F (229)	■		■	■	■	■		
Burgundy F (515)	■		■	■	■	■		
Capri Blue F (243)	■		■	■	■	■		
Chrysolite F (238)	■		■	■	■	■		
Citrine F (249)	■		■	■	■	■		
Cobalt F (369)	■		■	■	■	■		
Dark Indigo F (288)	■		■	■	■	■		
Dark Moss Green F (260)	■		■	■	■	■		
Denim Blue F (266)	■		■	■	■	■		
Emerald F (205)	■		■	■	■	■		
Erinite F (360)	■		■	■	■	■		
Fern Green F (291)	■		■	■	■	■		
Fireopal F (237)	■		■	■	■	■		
Fuchsia F (502)	■		■	■	■	■		
Greige F (284)	■		■	■	■	■		
Hyacinth F (236)	■		■	■	■	■		
Indian Pink F (289)	■		■	■	■	■		
Indian Siam F (327)	■		■	■	■	■		
Jet (280)	■	■		■	■	■		
Jet F (280)	■	■		■	■	■		
Jonquil F (213)	■		■	■	■	■		
Light Amethyst F (212)	■		■	■	■	■		
Light Colorado Topaz F (246)	■	■		■	■	■		
Light Peach F (362)	■		■	■	■	■		
Light Rose F (223)	■		■	■	■	■		
Light Sapphire F (211)	■		■	■	■	■		
Light Siam F (227)	■	■		■	■	■		
Light Silk F (261)	■		■	■	■	■		
Light Topaz F (226)	■		■	■	■	■		
Light Turquoise F (263)	■		■	■	■	■		
Mocca F (286)	■		■	■	■	■		
Montana F (207)	■		■	■	■	■		
Olivine F (228)	■		■	■	■	■		
Padparadscha F (542)	■		■	■	■	■		

Flat Backs No Hotfix

08 Flat Backs No Hotfix

2088		Size	SS 12	SS 14	SS 16	SS 20	SS 30	SS 34	SS 40	SS 48
Peridot F (214)			■		■	■	■	■		
Provence Lavender F (283)			■		■	■	■			
Purple Velvet F (277)			■		■	■	■	■		
Rose F (209)			■		■	■	■	■		
Rose Peach F (262)			■		■	■	■	■		
Ruby F (501)			■		■	■	■	■		
Sapphire F (206)			■		■	■	■	■		
Siam F (208)			■		■	■	■	■		
Silk F (391)			■		■	■	■	■		
Smoked Topaz F (220)			■		■	■	■	■		
Sun F (248)			■		■	■	■	■		
Sunflower F (292)			■		■	■	■	■		
Tangerine F (259)			■		■	■	■	■		
Tanzanite F (539)			■	■	■	■	■	■		
Topaz F (203)			■	■	■	■	■	■		
Vintage Rose F (319)			■		■	■	■	■		
Opal Colors										
Air Blue Opal F (285)			■		■	■	■	■		
Caribbean Blue Opal F (394)			■		■	■	■	■		
Chrysolite Opal F (294)			■		■	■	■	■		
Cyclamen Opal F (398)			■		■	■	■	■		
Pacific Opal F (390)			■		■	■	■	■		
White Opal F (234)			■		■	■	■	■		
Crystal Effects										
Transparent Effects										
Crystal AB F (001 AB)			■	■	■	■	■	■	■	■
Crystal Antique Pink F (001 ANTP)			■		■	■	■	■		
Crystal Blue Shade F (001 BLSH)			■		■	■	■	■		
Crystal Bronze Shade F (001 BRSH)			■		■	■	■			
Crystal Copper F (001 COP)			■		■	■	■	■		
Crystal Cosmojet F (001 COS)			■		■	■	■	■		
Crystal Golden Shadow F (001 GSHA)			■		■	■	■	■		
Crystal Lilac Shadow F (001 LISH)			■		■	■	■	■		
Crystal Luminous Green F (001 LUMG)			■		■	■	■	■		
Crystal Meridian Blue F (001 MBL)			■		■	■	■			
Crystal Moonlight F (001 MOL)			■		■	■	■	■		
Crystal Red Magma F (001 REDM)			■		■	■	■	■		
Crystal Silver Night F (001 SINI)			■		■	■	■	■		
Crystal Silver Shade F (001 SSHA)			■		■	■	■	■		
Crystal Volcano F (001 VOL)			■		■	■				

Flat Backs No Hotfix

2088		Size	SS 12	SS 14	SS 16	SS 20	SS 30	SS 34	SS 40	SS 48
Metallic Effects										
	Crystal Dorado F (001 DOR)		■		■	■	■	■		
	Crystal Iridescent Green F (001 IRIG)		■		■	■	■	■		
	Crystal Metallic Blue F (001 METBL)		■		■	■	■	■		
	Crystal Metallic Light Gold F (001 MLGLD)		■		■	■	■	■		
	Crystal Rose Gold F (001 ROGL)		■		■	■	■	■		
Color Effects										
Transparent Effects										
	Aquamarine AB F (202 AB)		■		■	■	■			
	Jonquil AB F (213 AB)		■		■	■	■			
	Light Rose AB F (223 AB)		■		■	■	■			
	Light Siam AB F (227 AB)		■		■	■	■			
	Peridot AB F (214 AB)		■		■	■	■			
	Rose AB F (209 AB)		■		■	■	■			
	Sapphire AB F (206 AB)		■		■	■	■			
	Topaz AB F (203 AB)		■		■	■	■			
Metallic Effects										
	Jet Hematite (280 HEM)		■		■	■	■	■		
	Jet Hematite F (280 HEM)		■		■	■	■	■		
	Jet Nut F (280 NUT)		■		■	■	■			

2200 Navette Flat Back

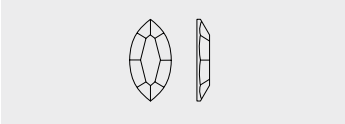
2200 Navette Flat Back		Size
 		8x4 mm
Crystal		
	Crystal F (001)	■

Flat Backs No Hotfix

2204 Pure Leaf Flat Back

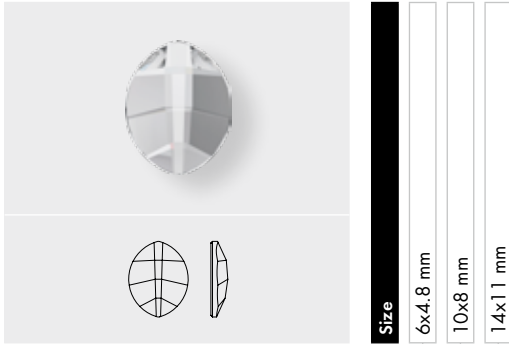

Size	6x4.8 mm	10x8 mm	14x11 mm
------	----------	---------	----------

Crystal

Crystal F (001)

Colors

Plain Colors

Amethyst F (204)

Dark Moss Green F (260)

Emerald F (205)

Jet (280)

Light Siam F (227)

Peridot F (214)

Crystal Effects

Transparent Effects

Crystal AB F (001 AB)

Crystal Blue Shade F (001 BLSH)

Crystal Golden Shadow F (001 GSHA)

Crystal Luminous Green F (001 LUMG)

Crystal Silver Night F (001 SINI)

2300 Drop Flat Back



Size	8x4.8 mm	10x6 mm
------	----------	---------

Crystal

Crystal F (001)

2400 Square Flat Back

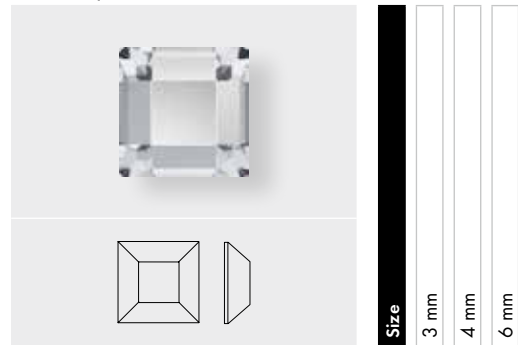

Size	3 mm	4 mm	6 mm
------	------	------	------

Crystal

Crystal F (001)

Flat Backs No Hotfix

2420 Asymmetric Square Flat Back ¹⁾

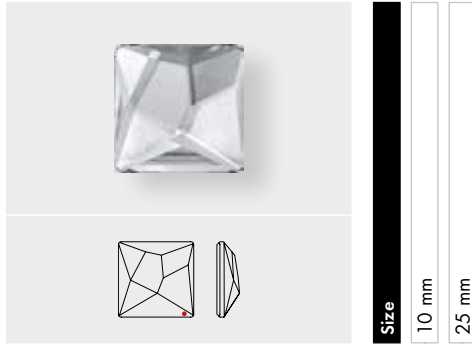

Size	
10 mm	25 mm

Crystal	
<input type="checkbox"/>	Crystal F (001)
<input type="checkbox"/>	Crystal CAL V SI (001 CAL V SI)
Crystal Effects	
Transparent Effects	
<input checked="" type="checkbox"/>	Crystal Bermuda Blue F (001 BBL)

2483 Classic Square Flat Back

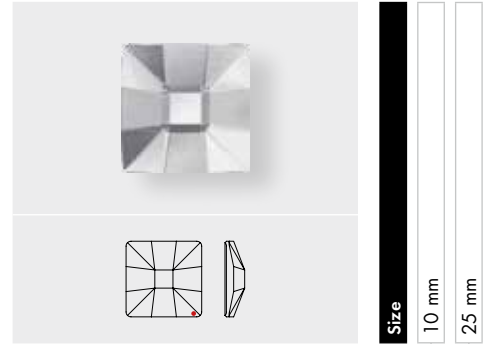

Size	
10 mm	25 mm

Crystal	
<input type="checkbox"/>	Crystal F (001)
<input type="checkbox"/>	Crystal CAL SI (001 CAL SI) ¹⁾⁺²⁾
<input type="checkbox"/>	Crystal CAL V SI (001 CAL V SI) ¹⁾
Colors	
Plain Colors	
<input checked="" type="checkbox"/>	Jet (280)

2493 Chessboard Flat Back

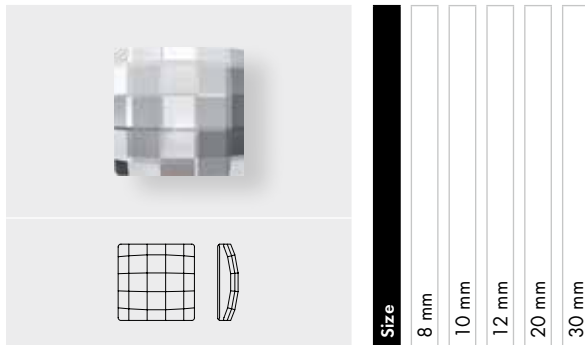

Size				
8 mm	10 mm	12 mm	20 mm	30 mm

Crystal	
<input type="checkbox"/>	Crystal F (001)
Colors	
Plain Colors	
<input type="checkbox"/>	Black Diamond F (215)
<input type="checkbox"/>	Jet F (280)
Crystal Effects	
Transparent Effects	
<input type="checkbox"/>	Crystal AB F (001 AB)
<input type="checkbox"/>	Crystal Golden Shadow F (001 GSHA)
Crystal Patina	
<input type="checkbox"/>	Crystal Black Patina F (001 BLAPA)
<input type="checkbox"/>	Crystal Gold Patina F (001 GOLPA)
<input type="checkbox"/>	Crystal Rose Patina F (001 ROSPA)
<input type="checkbox"/>	Crystal Silver Patina F (001 SILPA)
<input type="checkbox"/>	Crystal White Patina F (001 WHIPA)

2520 Cosmic Flat Back

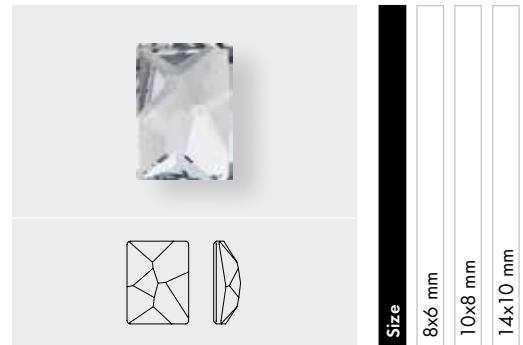

Size		
8x6 mm	10x8 mm	14x10 mm

Crystal	
<input type="checkbox"/>	Crystal F (001)
Colors	
Plain Colors	
<input checked="" type="checkbox"/>	Jet (280)
Crystal Effects	
Transparent Effects	
<input type="checkbox"/>	Crystal AB F (001 AB)
<input type="checkbox"/>	Crystal Golden Shadow F (001 GSHA)

¹⁾ Integrated articles of the former Bath & Wellness Collection may be partly delivered with a laser-engraved logo.

• The logo position is marked with a red dot.

²⁾ Coated on faceted side.

Flat Backs No Hotfix

2555 Cosmic Baguette Flat Back

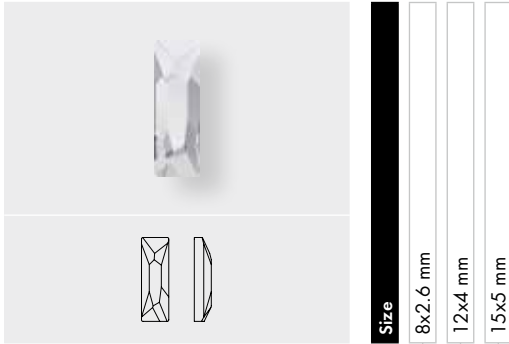

Crystal	8x2.6 mm	12x4 mm	15x5 mm
Crystal F (001)	<input type="checkbox"/>	<input type="checkbox"/>	<input type="checkbox"/>
Colors			
Plain Colors			
Jet (280)	<input type="checkbox"/>	<input type="checkbox"/>	<input type="checkbox"/>
Crystal Effect			
Transparent Effects			
Crystal Golden Shadow F (001 GSHA)	<input type="checkbox"/>	<input type="checkbox"/>	<input type="checkbox"/>

2570 Vigour Rectangle Flat Back ¹⁾



Crystal	50x16 mm
Crystal F (001)	<input type="checkbox"/>
Crystal CAL SI (001 CAL SI) ¹⁾⁺²⁾	<input type="checkbox"/>
Crystal CAL V SI (001 CAL V SI) ¹⁾	<input type="checkbox"/>

2585 Graphic Flat Back

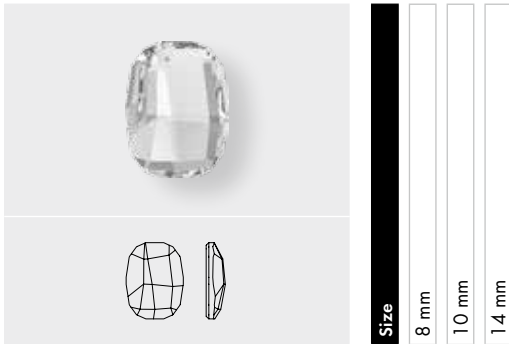

Crystal	8 mm	10 mm	14 mm
Crystal F (001)	<input type="checkbox"/>	<input type="checkbox"/>	<input type="checkbox"/>
Colors			
Plain Colors			
Rose Peach F (262)	<input type="checkbox"/>	<input type="checkbox"/>	<input type="checkbox"/>
Crystal Effects			
Transparent Effects			
Crystal AB F (001 AB)	<input type="checkbox"/>	<input type="checkbox"/>	<input type="checkbox"/>
Crystal Luminous Green F (001 LUMG)	<input type="checkbox"/>	<input type="checkbox"/>	<input type="checkbox"/>

2611 Solaris Flat Back



Crystal	8 mm	10 mm	14 mm
Crystal F (001)	<input type="checkbox"/>	<input type="checkbox"/>	<input type="checkbox"/>
Colors			
Plain Colors			
Aquamarine F (202)	<input type="checkbox"/>	<input type="checkbox"/>	<input type="checkbox"/>
Jet (280)	<input type="checkbox"/>	<input type="checkbox"/>	<input type="checkbox"/>
Light Rose F (223)	<input type="checkbox"/>	<input type="checkbox"/>	<input type="checkbox"/>
Crystal Effects			
Transparent Effects			
Crystal AB F (001 AB)	<input type="checkbox"/>	<input type="checkbox"/>	<input type="checkbox"/>
Crystal Golden Shadow F (001 GSHA)	<input type="checkbox"/>	<input type="checkbox"/>	<input type="checkbox"/>
Crystal Luminous Green F (001 LUMG)	<input type="checkbox"/>	<input type="checkbox"/>	<input type="checkbox"/>
Crystal Silver Night F (001 SINI)	<input type="checkbox"/>	<input type="checkbox"/>	<input type="checkbox"/>
Metallic Effects			
Crystal Iridescent Green F (001 IRIG)	<input type="checkbox"/>	<input type="checkbox"/>	<input type="checkbox"/>

¹⁾ Integrated articles of the former Bath & Wellness Collection may be partly delivered with a laser-engraved logo.

• The logo position is marked with a red dot.

²⁾ Coated on faceted side.

Flat Backs No Hotfix

2611/G Solaris Flat Back partly frosted

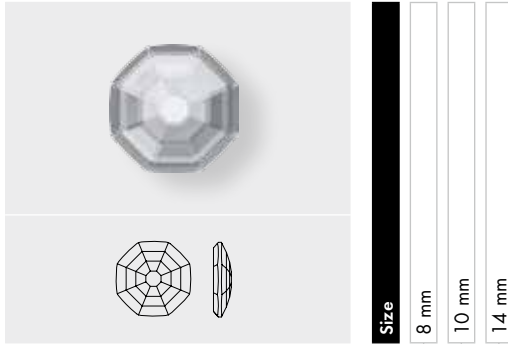

Size
8 mm
10 mm
14 mm

Crystal			
Crystal F (001)	■	■	■
Colors			
Plain Colors			
Aquamarine F (202)	■	■	■
Jet (280)	■	■	■
Light Rose F (223)	■	■	■
Crystal Effects			
Transparent Effects			
Crystal AB F (001 AB)	■	■	■
Crystal Golden Shadow F (001 GSHA)	■	■	■
Crystal Luminous Green F (001 LUMG)	■	■	■
Crystal Silver Night F (001 SINI)	■	■	■
Metallic Effects			
Crystal Iridescent Green F (001 IRIG)	■	■	■

2708 Molecule Flat Back

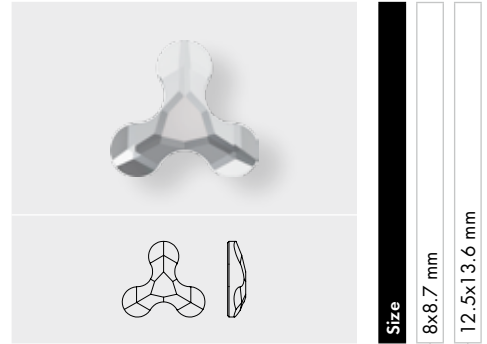

Size
8x8.7 mm
12.5x13.6 mm

Crystal			
Crystal F (001)	■	■	■
Colors			
Plain Colors			
Amethyst F (204)	■	■	■
Blue Zircon F (229)	■	■	■
Dark Moss Green F (260)	■	■	■
Denim Blue F (266)	■	■	■
Fuchsia F (502)	■	■	■
Jet (280)	■	■	■
Light Silk F (261)	■	■	■
Light Turquoise F (263)	■	■	■
Crystal Effects			
Transparent Effects			
Crystal AB F (001 AB)	■	■	■
Crystal Antique Pink F (001 ANTP)	■	■	■
Crystal Blue Shade F (001 BLSH)	■	■	■
Crystal Golden Shadow F (001 GSHA)	■	■	■
Crystal Silver Night F (001 SINI)	■	■	■
Metallic Effects			
Crystal Iridescent Green F (001 IRIG)	■	■	■
Crystal Rose Gold F (001 ROGL)	■	■	■

Flat Backs No Hotfix

2709 Rhombus Flat Back

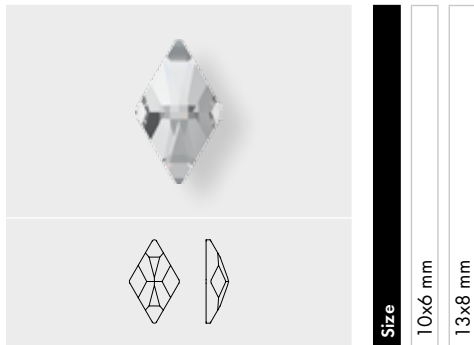

Size
10x6 mm
13x8 mm

Crystal

Crystal F (001)

Colors

Plain Colors

Aquamarine F (202)

Black Diamond F (215)

Light Rose F (223)

Light Siam F (227)

Crystal Effects

Transparent Effects

Crystal AB F (001 AB)

Crystal Golden Shadow F (001 GSHA)

Crystal Silver Shade F (001 SSHA)

2716 Rivoli Triangle Flat Back

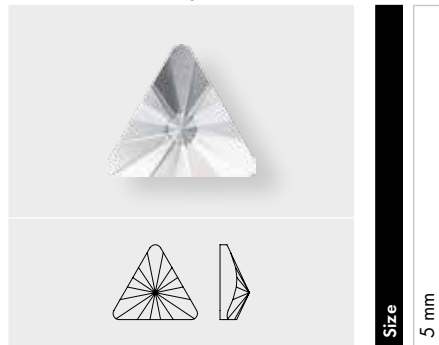

Size
5 mm

Crystal

Crystal F (001)

Crystal Effect

Transparent Effects

Crystal AB F (001 AB)

2720 Cosmic Delta Flat Back

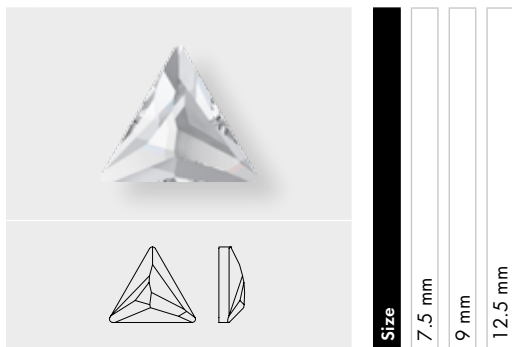

Size
7.5 mm
9 mm
12.5 mm

Crystal

Crystal F (001)

2770 Wing Flat Back

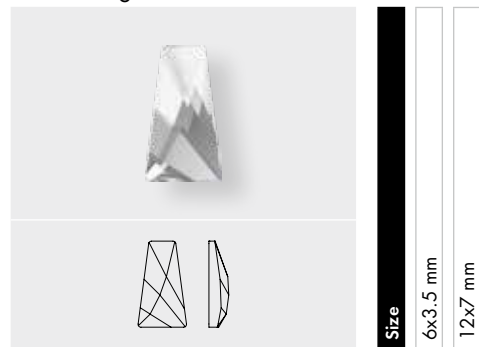

Size
6x3.5 mm
12x7 mm

Crystal

Crystal F (001)

Color

Plain Color

Black Diamond F (215)

Crystal Effects

Transparent Effects

Crystal Golden Shadow F (001 GSHA)

Crystal Silver Shade F (001 SSHA)

Flat Backs No Hotfix

2788 Wave Flat Back



Size	8 mm	10 mm	14 mm
Crystal			
Crystal F (001)	<input type="checkbox"/>	<input type="checkbox"/>	<input type="checkbox"/>

2797 Diamond Leaf Flat Back

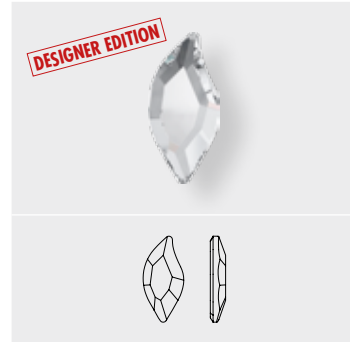

Size	8x4 mm	10x5 mm
Crystal		
Crystal F (001)	<input type="checkbox"/>	<input type="checkbox"/>
Crystal Effect		
Transparent Effects		
Crystal AB F (001 AB)	<input type="checkbox"/>	<input type="checkbox"/>

2808 Heart Flat Back

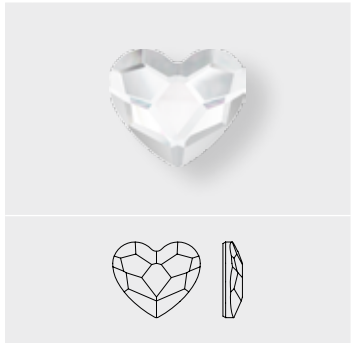

Size	6 mm	10 mm	14 mm
Crystal			
Crystal F (001)	<input type="checkbox"/>	<input type="checkbox"/>	<input type="checkbox"/>
Colors			
Plain Colors			
Dark Moss Green F (260)	<input type="checkbox"/>	<input type="checkbox"/>	<input type="checkbox"/>
Denim Blue F (266)	<input type="checkbox"/>	<input type="checkbox"/>	<input type="checkbox"/>
Fuchsia F (502)	<input type="checkbox"/>	<input type="checkbox"/>	<input type="checkbox"/>
Jet (280)	<input type="checkbox"/>	<input type="checkbox"/>	<input type="checkbox"/>
Light Siam F (227)	<input type="checkbox"/>	<input type="checkbox"/>	<input type="checkbox"/>
Light Silk F (261)	<input type="checkbox"/>	<input type="checkbox"/>	<input type="checkbox"/>
Rosaline F (508)	<input type="checkbox"/>	<input type="checkbox"/>	<input type="checkbox"/>
Crystal Effects			
Transparent Effects			
Crystal AB F (001 AB)	<input type="checkbox"/>	<input type="checkbox"/>	<input type="checkbox"/>
Crystal Antique Pink F (001 ANTTP)	<input type="checkbox"/>	<input type="checkbox"/>	<input type="checkbox"/>
Crystal Astral Pink F (001 API)	<input type="checkbox"/>	<input type="checkbox"/>	<input type="checkbox"/>
Crystal Golden Shadow F (001 GSHA)	<input type="checkbox"/>	<input type="checkbox"/>	<input type="checkbox"/>
Metallic Effects			
Crystal Rose Gold F (001 ROGL)	<input type="checkbox"/>	<input type="checkbox"/>	<input type="checkbox"/>
Crystal Patina			
Crystal Black Patina F (001 BLAPA)	<input type="checkbox"/>	<input type="checkbox"/>	<input type="checkbox"/>
Crystal Gold Patina F (001 GOLPA)	<input type="checkbox"/>	<input type="checkbox"/>	<input type="checkbox"/>
Crystal Rose Patina F (001 ROSPA)	<input type="checkbox"/>	<input type="checkbox"/>	<input type="checkbox"/>
Crystal Silver Patina F (001 SILPA)	<input type="checkbox"/>	<input type="checkbox"/>	<input type="checkbox"/>
Crystal White Patina F (001 WHIPA)	<input type="checkbox"/>	<input type="checkbox"/>	<input type="checkbox"/>

Flat Backs No Hotfix

2816 Rivoli Star Flat Back

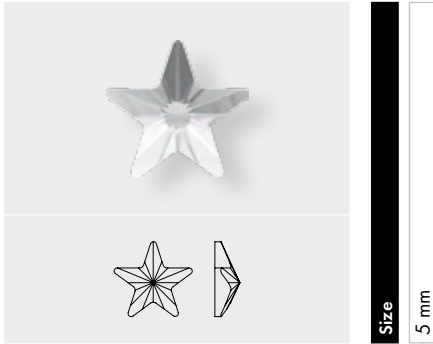

Size
5 mm

- Crystal**
- Crystal F (001)
- Crystal Effects**
- Transparent Effects**
- Crystal AB F (001 AB)

2826 Rivoli Snowflake Flat Back

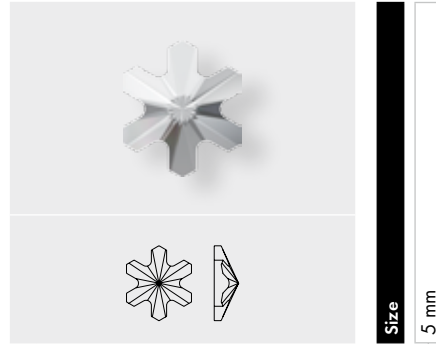

Size
5 mm

- Crystal**
- Crystal F (001)
- Crystal Effects**
- Transparent Effects**
- Crystal AB F (001 AB)

2854 Butterfly Flat Back

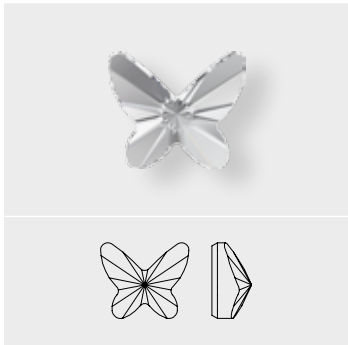

Size
8 mm
12 mm
18 mm

- Crystal**
- Crystal F (001)
- Colors**
- Plain Colors**
- Amethyst F (204)
- Denim Blue F (266)
- Light Rose F (223)
- Rose Peach F (262)
- Crystal Effects**
- Transparent Effects**
- Crystal AB F (001 AB)
- Crystal Antique Pink F (001 ANTP)
- Crystal Golden Shadow F (001 GSHA)
- Crystal Silver Night F (001 SINI)

2858 Bow Tie Flat Back

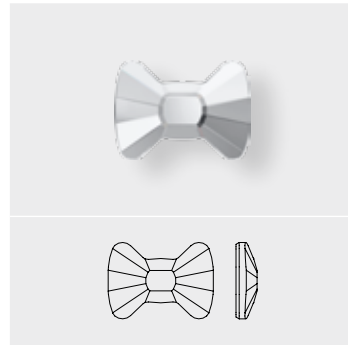

Size
6x4.5 mm
9x6.5 mm
12x8.5 mm

- Crystal**
- Crystal F (001)
- Colors**
- Plain Colors**
- Denim Blue F (266)
- Jet (280)
- Light Amethyst F (212)
- Light Siam F (227)
- Tangerine F (259)
- Vintage Rose F (319)
- Opal Colors**
- White Opal F (234)
- Crystal Effects**
- Transparent Effects**
- Crystal AB F (001 AB)
- Crystal Golden Shadow F (001 GSHA)
- Crystal Luminous Green F (001 LUMG)
- Crystal Silver Night F (001 SINI)
- Metallic Effects**
- Crystal Iridescent Green F (001 IRIG)

Flat Backs No Hotfix

PRODUCT DETAILS

Article Size	Packing Unit = Minimum Order Quantity in Pieces	Average Net Weight in Gram per Packing Unit Crystal (001)	Average Gross Weight in Gram per Packing Unit Crystal (001)
2000			
SS 3	1,440	1.8	12.7
SS 4	1,440	3.3	13.7
2006			
10 mm	288	89.9	116.4
12 mm	144	87.2	110.9
14 mm	144	132.4	158.7
16 mm	144	188.6	222.4
2035			
6 mm	360	27.1	34.8
10 mm	192	56.2	88.0
14 mm	96	88.4	109.0
20 mm	40	82.0	121.4
30 mm	12	95.4	130.8
40 mm	6	105.3	140.3
2037			
8 mm	240	14.48	23.58
14 mm	72	12.05	39.99
17 mm	72	27.72	52.20
2058			
SS 5	1,440	4.36	17.87
SS 6	1,440	5.66	17.62
SS 7	1,440	7.06	19.01
SS 8	1,440	10.11	19.63
SS 9	1,440	12.44	21.95
SS 10	1,440	15.79	25.30
2058/B			
SS 7	1,440	7.06	19.01
SS 9	1,440	10.11	19.63
SS 12	1,440	22.06	30.26
SS 16	1,440	39.89	49.83
SS 20	1,440	72.20	80.89
2072			
8 mm	288	92.9	119.6
10 mm	144	90.6	111.0
12 mm	72	82.0	100.1
2088			
SS 12	1,440	22.06	30.26
SS 14	1,440	30.09	38.30
SS 16	1,440	39.89	49.83
SS 20	1,440	72.20	80.89
SS 30	288	34.56	63.02
SS 34	144	25.92	48.59
SS 40	144	50.04	75.07
SS 48	96	76.13	101.33
2200			
8x4 mm	720	49.6	60.2
2204			
6x4.8 mm	360	27.237	36.368
10x8 mm	144	31.450	53.332
14x11 mm	108	52.618	74.012

Flat Backs No Hotfix

08 Flat Backs No Hotfix

Article Size	Packing Unit = Minimum Order Quantity in Pieces	Average Net Weight in Gram per Packing Unit Crystal (001)	Average Gross Weight in Gram per Packing Unit Crystal (001)
2300			
8x4.8 mm	720	83.9	94.5
10x6 mm	360	56.9	67.8
2400			
3 mm	1,440	25.3	36.8
4 mm	720	30.0	41.0
6 mm	144	21.6	32.5
2420			
10 mm	144	91.6	118.2
25 mm	32	200.8	251.8
2483			
10 mm	144	90.3	120.2
25 mm	32	233.3	261.5
2493			
8 mm	216	72.3	91.8
10 mm	144	84.4	106.1
12 mm	96	96.4	127.8
20 mm	24	108.5	137.9
30 mm	6	92.4	123.2
2520			
8x6 mm	288	50.8	80.2
10x8 mm	144	72.3	90.4
14x10 mm	144	119.3	140.8
2555			
8x2.6 mm	240	18.4	27.5
12x4 mm	144	28.8	33.6
15x5 mm	72	28.9	46.0
2570			
50x16 mm	6	52.9	81.6
2585			
8 mm	288	48.21	68.08
10 mm	288	72.32	104.28
14 mm	144	106.06	145.52
2611			
8 mm	144	29.400	38.548
10 mm	216	93.623	115.940
14 mm	48	42.336	63.504
2611/G			
8 mm	144	29.400	38.548
10 mm	216	93.623	115.940
14 mm	48	42.336	63.504
2708			
8x8.7 mm	288	28.063	57.335
12.5x13.6 mm	96	49.318	69.271
2709			
10x6 mm	288	48.2	73.6
13x8 mm	144	41.0	60.1
2716			
5 mm	720	35.78	75.11

Flat Backs No Hotfix

Article Size	Packing Unit = Minimum Order Quantity in Pieces	Average Net Weight in Gram per Packing Unit Crystal (001)	Average Gross Weight in Gram per Packing Unit Crystal (001)
2720			
7.5 mm	240	27.9	37.0
9 mm	180	45.1	54.2
12.5 mm	144	71.1	87.1
2770			
6x3.5 mm	1,440	60.3	70.3
12x7 mm	192	49.8	98.4
2788			
8 mm	288	7.54	18.43
10 mm	216	10.54	37.75
14 mm	144	16.99	45.07
2797			
8x4 mm	240	14.9	24.0
10x15 mm	180	23.4	32.6
2808			
6 mm	288	19.772	28.919
10 mm	144	38.823	55.902
14 mm	96	56.448	86.849
2816			
5 mm	720	23.56	30.69
2826			
5 mm	720	23.06	30.07
2854			
8 mm	216	35.98	52.18
12 mm	144	84.37	103.81
18 mm	72	120.53	144.22
2858			
6x4.5 mm	240	12.51	21.66
9x6.5 mm	144	23.39	44.05
12x8.5 mm	96	28.71	49.79

Flat Backs Hotfix

Flat Backs Hotfix are loose crystal elements with a flat reverse side that has been pre-coated with a heat-sensitive glue. These Flat Backs can be easily applied to a large range of textile carrier materials using heat to produce a durable and long-lasting crystal effect.

Flat Backs Hotfix are available in a multitude of colours, shapes and cuts. The increased light reflection and warmer appearance of the Flat Back Rose are achieved through a particular silver mirror on the reverse side.

The most innovative single item in this product group is art. 2078 XIRIUS Rose, with its most progressive and unique cut in the market: multilayer cut technology creates the inspiring XIRIUS star design. Superior fire and a rich, well balanced cloud of light points redefine the market standard.

Swarovski's outstanding quality standards of crystal elements are underlined by highest precision in table size and diameter.

COLORS & EFFECTS

Colors

-  Crystal 001
-  Chalkwhite 279
-  White Opal 234
-  Light Silk 261
-  Silk 391
-  Light Peach 362
-  Rosaline 508
-  Vintage Rose 319
-  Light Rose 223
-  Rose Peach 262
-  Padparadscha 542
-  Indian Pink 289
-  Sun 248
-  Fireopal* 237
-  Hyacinth 236
-  Light Siam 227
-  Indian Siam* 327
-  Rose 209
-  Fuchsia 502
-  Ruby 501
-  Siam 208
-  Burgundy 515
-  Amethyst 204
-  Purple Velvet 277
-  Cobalt 369
-  Tanzanite 539

-  Light Amethyst 212
-  Provence Lavender 283
-  Light Sapphire 211
-  Aquamarine 202
-  Sapphire 206
-  Capri Blue 243
-  Dark Indigo 288
-  Montana 207
-  Caribbean Blue Opal 394
-  Light Turquoise 263
-  Blue Zircon 229
-  Denim Blue 266
-  Black Diamond 215
-  Pacific Opal 390
-  Chrysolite 238
-  Peridot 214
-  Erinite 360
-  Fern Green 291
-  Dark Moss Green 260
-  Emerald 205
-  Olivine 228
-  Khaki 550
-  Greige 284
-  Light Grey Opal 383
-  Light Colorado Topaz 246
-  Jonquil 213
-  Citrine 249

-  Light Topaz 226
-  Sunflower 292
-  Topaz 203
-  Tangerine 259
-  Smoked Topaz 220
-  Mocca 286
-  Jet 280

Ceramics

-  Marbled Light Grey 657
-  Marbled Terracotta 655
-  Marbled Yellow 652
-  Marbled Blue 654
-  Marbled Black 653

Effects

-  Crystal Hotfix Transparent* 001 HFT
-  Crystal Silver Shade 001 SSHA
-  Crystal Moonlight 001 MOL
-  Crystal Aurore Boreale 001 AB
-  Crystal Luminous Green** 001 LUMG
-  Crystal Golden Shadow 001 GSHA
-  Crystal Rose Gold 001 ROGL
-  Crystal Copper** 001 COP
-  Crystal Astral Pink 001 API
-  Light Siam Aurore Boreale 227 AB
-  Light Siam Satin** 227 SAT

Cabochons

-  Crystal White Pearl HF 001 650
-  Crystal Nacre HF 001 191
-  Crystal Creampearl HF 001 291
-  Crystal Golden Shadow HF 001 GSHA
-  Crystal Bronze Pearl HF 001 295
-  Crystal Rosaline Pearl HF 001 294
-  Crystal Chrome V HF 001 CHRMV
-  Crystal Light Grey Pearl HF 001 616
-  Crystal Dark Grey Pearl HF 001 617
-  Jet HF 280
-  Jet Hematite HF 280 HEM

Gemcolors

-  Crystal Pink Coral Pearl HF 001 716
-  Crystal Red Coral Pearl HF 001 718
-  Crystal Turquoise Pearl HF 001 709
-  Crystal Jade Pearl HF 001 715

-  Crystal Red Magma 001 REDM
-  Light Rose Aurore Boreale 223 AB
-  Crystal Antique Pink 001 ANTP
-  Crystal Transmission Hotfix Transparent 001 TRA HFT
-  Crystal Volcano 001 VOL
-  Crystal Lilac Shadow 001 LISH
-  Sapphire Satin** 206 SAT
-  Crystal Metallic Blue** 001 METBL
-  Crystal Meridian Blue 001 MBL
-  Crystal Blue Shade 001 BLSH
-  Blue Zircon Satin** 229 SAT
-  Jonquil Aurore Boreale 213 AB
-  Jonquil Satin** 213 SAT
-  Crystal Tabac 001 TAB
-  Crystal Iridescent Green 001 IRIG
-  Crystal Dorado** 001 DOR
-  Crystal Metallic Light Gold** 001 MLGLD
-  Crystal Bronze Shade** 001 BRSH
-  Smoked Topaz Satin** 220 SAT
-  Crystal Silver Night 001 SINI
-  Jet Nut** 280 NUT
-  Crystal Cosmojet* 001 COS
-  Jet Hematite** 280 HEM
-  Jet Aurore Boreale 280 AB

Numerical Order

001	Crystal	001 MLGLD	<u>Crystal Metallic Light Gold**</u>	223 AB	Light Rose Aurore Boreale	280 NUT	Jet Nut**
001 191	Crystal Narce HF	001 MOL	Crystal Moonlight	226	Light Topaz	283	Provence Lavender
001 291	Crystal Creampearl HF	001 REDM	<u>Crystal Red Magma</u>	227	Light Siam	284	Greige
001 294	Crystal Rosaline Pearl HF	001 ROGL	<u>Crystal Rose Gold</u>	227 AB	Light Siam Aurore Boreale	286	Mocca
001 295	Crystal Bronze Pearl HF	001 SINI	<u>Crystal Silver Night</u>	227 SAT	Light Siam Satin**	288	<u>Dark Indigo</u>
001 616	Crystal Light Grey Pearl HF	001 SSHA	<u>Crystal Silver Shade</u>	228	Olivine	289	Indian Pink
001 617	Crystal Dark Grey Pearl HF	001 TAB	<u>Crystal Tabac</u>	229	Blue Zircon	291	<u>Fern Green</u>
001 650	Crystal White Pearl HF	001 TRA HFT	<u>Crystal Transmission Hofix Transparent</u>	229 SAT	Blue Zircon Satin**	292	<u>Sunflower</u>
001 709	Crystal Turquoise Pearl HF	001 VOL	Crystal Volcano	234	White Opal	319	<u>Vintage Rose</u>
001 715	Crystal Jade Pearl HF	202	Aquamarine	236	Hyacinth	327	<u>Indian Siam*</u>
001 716	Crystal Pink Coral Pearl HF	203	Topaz	237	Fireopal*	360	<u>Erinite</u>
001 718	Crystal Red Coral Pearl HF	204	Amethyst	238	Chrysolite	362	Light Peach
001 AB	Crystal Aurore Boreale	205	Emerald	243	Capri Blue	369	Cobalt
001 ANTP	<u>Crystal Antique Pink</u>	206	Sapphire	246	Light Colorado Topaz	383	<u>Light Grey Opal</u>
001 API	<u>Crystal Astral Pink</u>	206 SAT	Sapphire Satin**	248	Sun	390	<u>Pacific Opal</u>
001 BLSH	<u>Crystal Blue Shade</u>	207	Montana	249	Citrine	391	Silk
001 BRSH	<u>Crystal Bronze Shade**</u>	208	Siam	259	<u>Tangerine</u>	394	<u>Caribbean Blue Opal</u>
001 CHRMV	Crystal Chrome V HF	209	Rose	260	<u>Dark Moss Green</u>	501	Ruby
001 COP	<u>Crystal Copper**</u>	211	Light Sapphire	261	Light Silk	502	Fuchsia
001 COS	<u>Crystal Cosmojet*</u>	212	Light Amethyst	262	<u>Rose Peach</u>	508	Rosaline
001 DOR	Crystal Dorado**	213	Jonquil	263	Light Turquoise	515	Burgundy
001 GSHA	<u>Crystal Golden Shadow</u>	213 AB	Jonquil Aurore Boreale	266	Denim Blue	539	Tanzanite
001 GSHA HF	<u>Crystal Golden Shadow HF</u>	213 SAT	Jonquil Satin**	277	Purple Velvet	542	<u>Padparadscha</u>
001 HFT	<u>Crystal Hofix Transparent*</u>	214	Peridot	279	Chalkwhite	550	<u>Khaki</u>
001 IRIG	<u>Crystal Iridescent Green</u>	215	Black Diamond	280	Jet	652	<u>Marbled Yellow</u>
001 LISH	<u>Crystal Lilac Shadow</u>	220	Smoked Topaz	280	Jet HF	653	<u>Marbled Black</u>
001 LUMG	<u>Crystal Luminous Green**</u>	220 SAT	Smoked Topaz Satin**	280 AB	Jet Aurore Boreale	654	<u>Marbled Blue</u>
001 MBL	<u>Crystal Meridian Blue</u>	223	Light Rose	280 HEM	Jet Hematite**	655	<u>Marbled Terracotta</u>
001 METBL	<u>Crystal Metallic Blue**</u>			280 HEM	Jet Hematite HF	657	<u>Marbled Light Grey</u>

Alphabetical Order

Amethyst (204)	Crystal Jade Pearl HF (001 715)	Fuchsia (502)	<u>Marbled Blue (654)</u>
Aquamarine (202)	Crystal Light Grey Pearl HF (001 616)	<u>Greige (284)</u>	<u>Marbled Light Grey (657)</u>
Black Diamond (215)	<u>Crystal Lilac Shadow (001 LISH)</u>	Hyacinth (236)	<u>Marbled Terracotta (655)</u>
Blue Zircon (229)	<u>Crystal Luminous Green (001 LUMG)**</u>	Indian Pink (289)	<u>Marbled Yellow (652)</u>
Blue Zircon Satin (229 SAT)**	<u>Crystal Meridian Blue (001 MBL)</u>	<u>Indian Siam (327)*</u>	Mocca (286)
Burgundy (515)	Crystal Metallic Blue (001 METBL)**	Jet (280)	Montana (207)
Capri Blue (243)	<u>Crystal Metallic Light Gold (001 MLGLD)**</u>	Jet Aurore Boreale (280 AB)	Olivine (228)
Caribbean Blue Opal (394)	Crystal Moonlight (001 MOL)	Jet Hematite (280 HEM)**	<u>Pacific Opal (390)</u>
Chalkwhite (279)	Crystal Narce HF (001 191)	Jet Hematite HF (280 HEM)	<u>Padparadscha (542)</u>
Chrysolite (238)	Crystal Pink Coral Pearl HF (001 716)	Jet HF (280)	Peridot (214)
Citrine (249)	Crystal Red Coral Pearl HF (001 718)	Jet Nut (280 NUT)**	Provence Lavender (283)
Cobalt (369)	<u>Crystal Red Magma (001 REDM)</u>	Jonquil (213)	Purple Velvet (277)
Crystal (001)	Crystal Rosaline Pearl HF (001 294)	Jonquil Aurore Boreale (213 AB)	Rosaline (508)
<u>Crystal Antique Pink (001 ANTP)</u>	<u>Crystal Rose Gold (001 ROGL)</u>	Jonquil Satin (213 SAT)**	Rose (209)
<u>Crystal Astral Pink (001 API)</u>	<u>Crystal Silver Night (001 SINI)</u>	<u>Khaki (550)</u>	<u>Rose Peach (262)</u>
Crystal Aurore Boreale (001 AB)	<u>Crystal Silver Shade (001 SSHA)</u>	Light Amethyst (212)	Ruby (501)
<u>Crystal Blue Shade (001 BLSH)</u>	<u>Crystal Tabac (001 TAB)</u>	Light Colorado Topaz (246)	Sapphire (206)
Crystal Bronze Pearl HF (001 295)	<u>Crystal Transmission Hofix Transparent (001 TRA HFT)</u>	<u>Light Grey Opal (383)</u>	Sapphire Satin (206 SAT)**
<u>Crystal Bronze Shade (001 BRSH)**</u>	Crystal Turquoise Pearl HF (001 709)	Light Peach (362)	Siam (208)
Crystal Chrome V HF (001 CHRMV)	Crystal Volcano (001 VOL)	Light Rose (223)	Silk (391)
<u>Crystal Copper (001 COP)**</u>	Crystal White Pearl HF (001 650)	Light Rose Aurore Boreale (223 AB)	Smoked Topaz (220)
<u>Crystal Cosmojet (001 COS)*</u>	<u>Dark Indigo (288)</u>	Light Sapphire (211)	Smoked Topaz Satin (220 SAT)**
Crystal Creampearl HF (001 291)	<u>Denim Blue (266)</u>	Light Siam (227)	<u>Sunflower (292)</u>
Crystal Dark Grey Pearl HF (001 617)	Emerald (205)	Light Siam Aurore Boreale (227 AB)	<u>Tangerine (259)</u>
Crystal Dorado (001 DOR)**	Erinite (360)	Light Siam Satin (227 SAT)**	Sun (248)
<u>Crystal Golden Shadow (001 GSHA)</u>	<u>Fern Green (291)</u>	<u>Light Silk (261)</u>	Tanzanite (539)
<u>Crystal Golden Shadow HF (001 GSHA HF)</u>	<u>Fireopal (237)*</u>	Light Topaz (226)	Topaz (203)
<u>Crystal Hofix Transparent (001 HFT)*</u>		Light Turquoise (263)	<u>Vintage Rose (319)</u>
<u>Crystal Iridescent Green (001 IRIG)</u>		<u>Marbled Black (653)</u>	White Opal (234)

This color chart is valid for the product groups Flat Backs Hofix and Sew-on Stones.

The displayed assortment is not entirely available for all products within the product groups. For details on available colors and effects, please see the product matrix for the respective item.

Classic Colors: This color range offers a wide choice of traditional Swarovski crystal colors.

Exclusive Colors: This color range is offered exclusively by Swarovski.

The standard assortment of colors and effects may vary according to the product group.

Slight changes in shades are unavoidable. Colors may vary according to cut and shape.

* Only available in limited sizes.

** Crystals are not resistant to plating and similar processing.

Flat Backs Hotfix

SUMMARY

1	2		1	2		1	2	
		2000 A HF SS 3			2520 M HF 8x6, 10x8, 14x10 mm			2797 M HF 8x4 mm
		2035 M HF 6, 10, 14, 20 mm			2555 M HF 8x2.6, 12x4, 15x5 mm			2808 M HF 6, 10, 14 mm
		2037 M HF 8, 14, 17 mm			2585 M HF 8, 10, 14 mm			2816 M HF 5 mm
		2038 A HF SS 5, 6, 8, 10			2610 M HF 6x4 mm			2817 M HF 5 mm
		2038/B HF SS 8, 10, 12, 16, 20			2611 M HF 8, 10, 14 mm			2826 M HF 5 mm
		2078 A HF SS 12, 16, 20, 30, 34, 40, 48			2611/G M HF 8, 10, 14 mm			2855 M HF 8 mm
		2080/4 HF SS 10, 16, 34			2708 M HF 8x8.7, 12.5x13.6 mm			2855/G M HF 8 mm
		2200 M HF 8x4 mm			2709 M HF 10x6 mm			2858 M HF 6x4.5, 9x6.5, 12x8.5 mm
		2204 M HF 6x4.8, 10x8, 14x11 mm			2711 M HF 6 mm			
		2300 M HF 8x4.8 mm			2716 M HF 5 mm			
		2400 M HF 3, 4 mm			2720 M HF 7.5, 9, 12.5 mm			
		2483 M HF 10 mm			2728 M HF SS 10, 16, 20, 34			
		2493 M HF 8, 10, 12, 20 mm			2770 M HF 6x3.5, 12x7, 16x9.5 mm			
		2510 M HF 5x2.5 mm			2788 M HF 8, 10, 14 mm			

Flat Backs Hotfix

2000 Rose

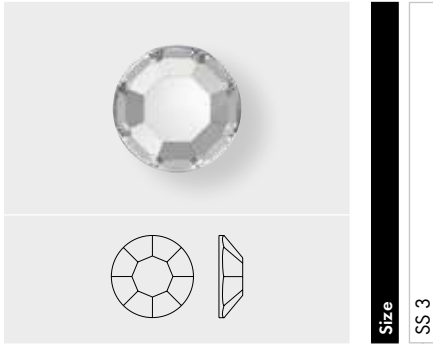

Size
SS 3

- Crystal**
- Crystal A HF (001)
- Colors**
- Plain Colors**
- Amethyst A HF (204)
- Aquamarine A HF (202)
- Black Diamond A HF (215)
- Jet A HF (280)
- Light Colorado Topaz A HF (246)
- Light Rose A HF (223)
- Montana A HF (207)
- Peridot A HF (214)
- Smoked Topaz A HF (220)
- Crystal Effect**
- Transparent Effects**
- Crystal AB A HF (001 AB)
- Crystal Golden Shadow HF (001 GSHA)
- Crystal Silver Shade HF (001 SSHA)
- Metallic Effects**
- Crystal Metallic Blue HF (001 METBL)
- Crystal Metallic Light Gold HF (001 MLGLD)
- Crystal Rose Gold HF (001 ROGL)
- Crystal Effect**
- Metallic Effects**
- Jet Hematite (280 HEM)

2035 Chessboard Circle Flat Back

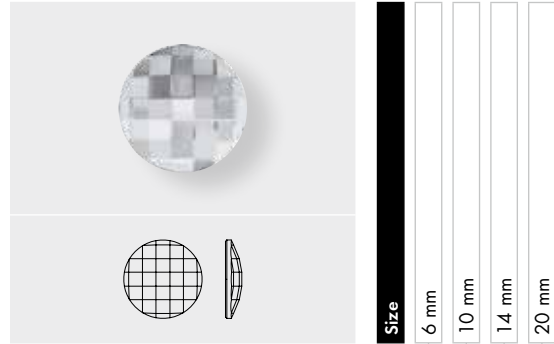

Size
6 mm
10 mm
14 mm
20 mm

- Crystal**
- Crystal M HF (001)
- Colors**
- Plain Colors**
- Jet M HF (280)
- Crystal Effects**
- Transparent Effects**
- Crystal AB M HF (001 AB)
- Crystal Golden Shadow M HF (001 GSHA)
- Crystal Red Magma M HF (001 REDM)

2037 Eclipse Flat Back

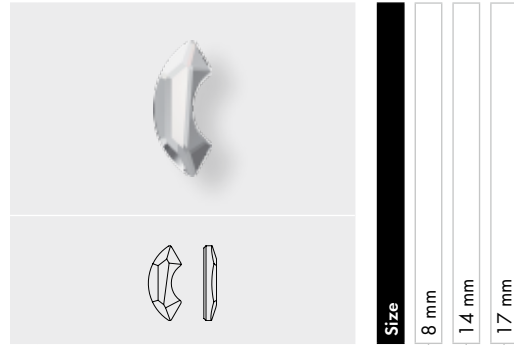

Size
8 mm
14 mm
17 mm

- Crystal**
- Crystal M HF (001)
- Crystal Effect**
- Transparent Effects**
- Crystal Golden Shadow M HF (001 GSHA)

Flat Backs Hotfix

2038 XILION Rose Hotfix

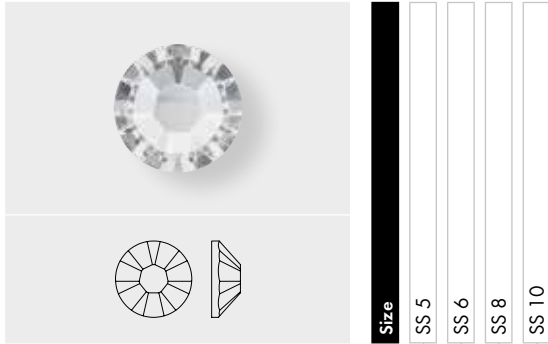

	Size	SS 5	SS 6	SS 8	SS 10
Crystal					
Crystal A HF (001)		■	■	■	■
Crystal Hotfix Transparent (001 HFT)			■	■	■
Colors					
Plain Colors					
Amethyst A HF (204)			■	■	■
Aquamarine A HF (202)			■	■	■
Black Diamond A HF (215)		■	■	■	■
Blue Zircon A HF (229)		■	■	■	■
Burgundy A HF (515)			■	■	■
Capri Blue A HF (243)		■	■	■	■
Chalkwhite A HF (279)			■	■	■
Chrysolite A HF (238)			■	■	■
Citrine A HF (249)			■	■	■
Cobalt A HF (369)			■	■	■
Dark Indigo A HF (288)			■	■	■
Dark Moss Green A HF (260)			■	■	■
Denim Blue A HF (266)			■	■	■
Emerald A HF (205)			■	■	■
Erinte A HF (360)			■	■	■
Fern Green A HF (291)			■	■	■
Fireopal A HF (237)					■
Fuchsia A HF (502)			■	■	■
Greige A HF (284)			■	■	■
Hyacinth A HF (236)			■	■	■
Indian Pink A HF (289)			■	■	■
Indian Siam A HF (327)			■	■	■
Jet A HF (280)		■	■	■	■
Jonquil A HF (213)			■	■	■
Khaki A HF (550)			■	■	■
Light Amethyst A HF (212)			■	■	■
Light Colorado Topaz A HF (246)		■	■	■	■
Light Peach A HF (362)			■	■	■
Light Rose A HF (223)		■	■	■	■
Light Sapphire A HF (211)			■	■	■
Light Siam A HF (227)		■	■	■	■
Light Silk A HF (261)			■	■	■
Light Topaz A HF (226)			■	■	■
Light Turquoise A HF (263)			■	■	■
Mocca A HF (286)			■	■	■
Montana A HF (207)			■	■	■

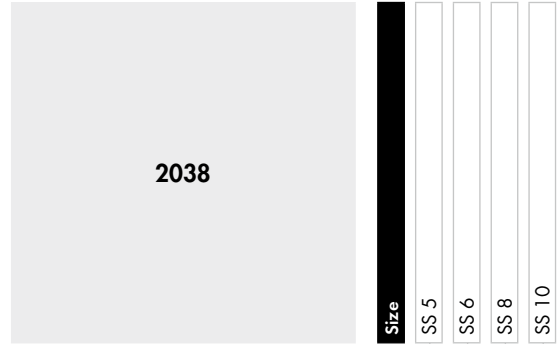

	Size	SS 5	SS 6	SS 8	SS 10
2038					
Olivine A HF (228)			■	■	■
Padparadscha A HF (542)			■	■	■
Peridot A HF (214)			■	■	■
Provence Lavender A HF (283)			■	■	■
Purple Velvet A HF (277)			■	■	■
Rose A HF (209)		■	■	■	■
Rose Peach A HF (262)			■	■	■
Ruby A HF (501)			■	■	■
Sapphire A HF (206)			■	■	■
Siam A HF (208)			■	■	■
Silk A HF (391)			■	■	■
Smoked Topaz A HF (220)			■	■	■
Sun A HF (248)			■	■	■
Sunflower A HF (292)			■	■	■
Tangerine A HF (259)			■	■	■
Tanzanite A HF (539)			■	■	■
Topaz A HF (203)			■	■	■
Vintage Rose A HF (319)			■	■	■
Opal Colors					
Caribbean Blue Opal A HF (394)			■	■	■
Light Grey Opal A HF (383)			■	■	■
Pacific Opal A HF (390)			■	■	■
White Opal A HF (234)			■	■	■
Crystal Effects					
Transparent Effects					
Crystal AB A HF (001 AB)		■	■	■	■
Crystal Antique Pink A HF (001 ANTP)			■	■	■
Crystal Blue Shade A HF (001 BLSH)			■	■	■
Crystal Bronze Shade A HF (001 BRSH)			■	■	■
Crystal Copper A HF (001 COP)			■	■	■
Crystal Cosmojet A HF (001 COS)			■	■	■
Crystal Golden Shadow A HF (001 GSHA)			■	■	■
Crystal Lilac Shadow A HF (001 LISH)			■	■	■
Crystal Luminous Green A HF (001 LUMG)			■	■	■
Crystal Meridian Blue A HF (001 MBL)			■	■	■
Crystal Moonlight A HF (001 MOL)			■	■	■
Crystal Silver Night A HF (001 SINI)			■	■	■
Crystal Silver Shade A HF (001 SSHA)			■	■	■
Crystal Tabac A HF (001 TAB)			■	■	■
Crystal Transmission HFT (001 TRA HFT)			■	■	■
Crystal Volcano A HF (001 VOL)			■	■	■

Flat Backs Hotfix

09 Flat Backs Hotfix

2038		Size	SS 5	SS 6	SS 8	SS 10
Metallic Effects						
	Crystal Dorado A HF (001 DOR)			■	■	■
	Crystal Iridescent Green A HF (001 IRIG)			■	■	■
	Crystal Metallic Blue A HF (001 METBL)			■	■	■
	Crystal Metallic Light Gold A HF (001 MLGLD)			■	■	■
	Crystal Rose Gold A HF (001 ROGL)			■	■	■
Color Effects						
Transparent Effects						
	Blue Zircon Satin A HF (229 SAT)			■	■	■
	Jet AB A HF (280 AB)			■	■	■
	Jonquil AB A HF (213 AB)			■	■	■
	Jonquil Satin A HF (213 SAT)			■	■	■
	Light Rose AB A HF (223 AB)			■	■	■
	Light Siam AB A HF (227 AB)			■	■	■
	Light Siam Satin A HF (227 SAT)			■	■	■
	Sapphire Satin A HF (206 SAT)			■	■	■
	Smoked Topaz Satin A HF (220 SAT)			■	■	■
Metallic Effects						
	Jet Hematite A HF (280 HEM)		■	■	■	■
	Jet Nut A HF (280 NUT)			■	■	■

2038/B XILION Rose Flat Back

2038/B XILION Rose Flat Back		Size	SS 8	SS 10	SS 12	SS 16	SS 20
Ceramics							
	Marbled Black HFT (653)		■	■	■	■	■
	Marbled Blue HFT (654)		■	■	■	■	■
	Marbled Light Grey HFT (657)		■	■	■	■	■
	Marbled Terracotta HFT (655)		■	■	■	■	■
	Marbled Yellow HFT (652)		■	■	■	■	■

Flat Backs Hotfix

2078 XIRIUS Rose Hotfix

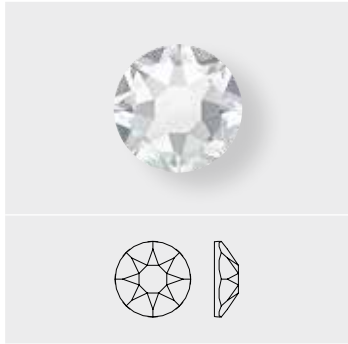

	SS 12	SS 16	SS 20	SS 30	SS 34	SS 40	SS 48
Crystal							
Crystal A HF (001)	■	■	■	■	■	■	■
Crystal Hotfix Transparent (001 HFT)		■					
Colors							
Plain Colors							
Amethyst A HF (204)	■	■	■	■	■		
Aquamarine A HF (202)	■	■	■	■	■		
Black Diamond A HF (215)	■	■	■	■	■		
Blue Zircon A HF (229)	■	■	■	■	■		
Burgundy A HF (515)	■	■	■	■	■		
Capri Blue A HF (243)	■	■	■	■	■		
Chalkwhite A HF (279)	■	■	■	■	■		
Chrysolite A HF (238)	■	■	■	■	■		
Citrine A HF (249)	■	■	■	■	■		
Cobalt A HF (369)	■	■	■	■	■		
Dark Indigo A HF (288)	■	■	■	■	■		
Dark Moss Green A HF (260)	■	■	■	■	■		
Denim Blue A HF (266)	■	■	■	■	■		
Emerald A HF (205)	■	■	■	■	■		
Erinte A HF (360)	■	■	■	■	■		
Fern Green A HF (291)	■	■	■	■	■		
Fireopal A HF (237)	■	■	■	■	■		
Fuchsia A HF (502)	■	■	■	■	■		
Greige A HF (284)	■	■	■	■	■		
Hyacinth A HF (236)	■	■	■	■	■		
Indian Pink A HF (289)	■	■	■	■	■		
Indian Siam A HF (327)	■	■	■	■	■		
Jet A HF (280)	■	■	■	■	■		
Jonquil A HF (213)	■	■	■	■	■		
Khaki A HF (550)	■	■	■	■	■		
Light Amethyst A HF (212)	■	■	■	■	■		
Light Colorado Topaz A HF (246)	■	■	■	■	■		
Light Peach A HF (362)	■	■	■	■	■		
Light Rose A HF (223)	■	■	■	■	■		
Light Sapphire A HF (211)	■	■	■	■	■		
Light Siam A HF (227)	■	■	■	■	■		
Light Silk A HF (261)	■	■	■	■	■		
Light Topaz A HF (226)	■	■	■	■	■		
Light Turquoise A HF (263)	■	■	■	■	■		
Mocca A HF (286)	■	■	■	■	■		
Montana A HF (207)	■	■	■	■	■		

Flat Backs Hotfix

09 Flat Backs Hotfix

2078		Size	SS 12	SS 16	SS 20	SS 30	SS 34	SS 40	SS 48
	Olivine A HF (228)		■	■	■		■		
	Padparadscha A HF (542)		■	■	■		■		
	Peridot A HF (214)		■	■	■	■	■		
	Provence Lavender A HF (283)		■	■	■		■		
	Purple Velvet A HF (277)		■	■	■		■		
	Rose A HF (209)		■	■	■	■	■		
	Rose Peach A HF (262)		■	■	■		■		
	Ruby A HF (501)		■	■	■		■		
	Sapphire A HF (206)		■	■	■	■	■		
	Siam A HF (208)		■	■	■	■	■		
	Silk A HF (391)		■	■	■		■		
	Smoked Topaz A HF (220)		■	■	■	■	■		
	Sun A HF (248)		■	■	■		■		
	Sunflower A HF (292)		■	■	■		■		
	Tangerine A HF (259)		■	■	■		■		
	Tanzanite A HF (539)		■	■	■		■		
	Topaz A HF (203)		■	■	■	■	■		
	Vintage Rose A HF (319)		■	■	■		■		
Opal Colors									
	Caribbean Blue Opal A HF (394)		■	■	■		■		
	Light Grey Opal A HF (383)		■	■	■		■		
	Pacific Opal A HF (390)		■	■	■		■		
	White Opal A HF (234)		■	■	■		■		
Crystal Effects									
Transparent Effects									
	Crystal AB A HF (001 AB)		■	■	■	■	■	■	■
	Crystal Antique Pink A HF (001 ANTP)		■	■	■		■		
	Crystal Blue Shade A HF (001 BLSH)		■	■	■		■		
	Crystal Bronze Shade A HF (001 BRSH)		■	■	■		■		
	Crystal Copper A HF (001 COP)		■	■	■		■		
	Crystal Cosmojet A HF (001 COS)		■	■					
	Crystal Golden Shadow A HF (001 GSHA)		■	■	■	■	■		
	Crystal Lilac Shadow A HF (001 LISH)		■	■	■		■		
	Crystal Luminous Green A HF (001 LUMG)		■	■	■		■		
	Crystal Meridian Blue A HF (001 MBL)		■	■	■		■		
	Crystal Moonlight A HF (001 MOL)		■	■	■		■		
	Crystal Silver Night A HF (001 SINI)		■	■	■		■		
	Crystal Silver Shade A HF (001 SSHA)		■	■	■		■		
	Crystal Tabac A HF (001 TAB)		■	■	■		■		
	Crystal Transmission HFT (001 TRA HFT)		■	■	■		■		
	Crystal Volcano A HF (001 VOL)		■	■	■				

Flat Backs Hotfix

2078		Size	SS 12	SS 16	SS 20	SS 30	SS 34	SS 40	SS 48
Metallic Effects									
	Crystal Dorado A HF (001 DOR)		■	■	■		■		
	Crystal Iridescent Green A HF (001 IRIG)		■	■	■		■		
	Crystal Metallic Blue A HF (001 METBL)		■	■	■		■		
	Crystal Metallic Light Gold A HF (001 MLGD)		■	■	■		■		
	Crystal Rose Gold A HF (001 ROGL)		■	■	■		■		
Color Effects									
Transparent Effects									
	Blue Zircon Satin A HF (229 SAT)		■	■	■		■		
	Jet AB A HF (280 AB)		■	■	■		■		
	Jonquil AB A HF (213 AB)		■	■	■		■		
	Jonquil Satin A HF (213 SAT)		■	■	■		■		
	Light Rose AB A HF (223 AB)		■	■	■		■		
	Light Siam AB A HF (227 AB)		■	■	■		■		
	Light Siam Satin A HF (227 SAT)		■	■	■		■		
	Sapphire Satin A HF (206 SAT)		■	■	■		■		
	Smoked Topaz Satin A HF (220 SAT)		■	■	■		■		
Metallic Effects									
	Jet Hematite A HF (280 HEM)		■	■	■	■	■		
	Jet Nut A HF (280 NUT)		■	■	■		■		

Flat Backs Hotfix

2080/4 Cabochon

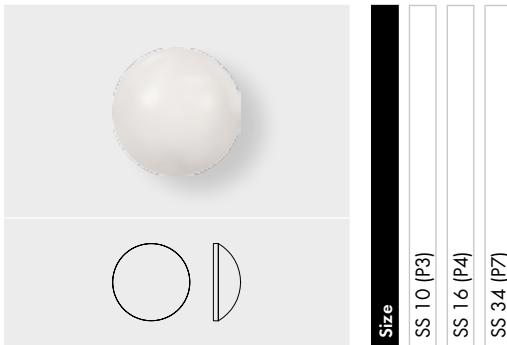

Colors	SS 10 (P3)	SS 16 (P4)	SS 34 (P7)
Plain Colors			
● Jet HF (280)	■	■	■
Crystal Pearl Colors			
● Crystal Bronze Pearl HF (001 295)	■	■	■
● Crystal Creampearl HF (001 291)	■	■	■
● Crystal Dark Grey Pearl HF (001 617)	■	■	■
● Crystal Light Grey Pearl HF (001 616)	■	■	■
● Crystal Rosaline Pearl HF (001 294)	■	■	■
● Crystal White Pearl HF (001 650)	■	■	■
Gemcolors			
● Crystal Jade Pearl HF (001 715)	■	■	■
● Crystal Pink Coral Pearl HF (001 716)	■	■	■
● Crystal Red Coral Pearl HF (001 718)	■	■	■
● Crystal Turquoise Pearl HF (001 709)	■	■	■
Crystal Effects			
Transparent Effects			
● Crystal Golden Shadow HF (001 GSHA)	■	■	■
● Crystal Nacre HF (001 191)	■	■	■
Metallic Effects			
● Crystal Chrom V HF (001 CHRMV)	■	■	■
Color Effects			
Metallic Effects			
● Jet Hematite HF (280 HEM)	■	■	■

2200 Navette Flat Back



Crystal	Size
● Crystal M HF (001)	8x4 mm
Colors	
Plain Colors	
● Jet M HF (280)	■
Crystal Effects	
Transparent Effects	
● Crystal AB M HF (001 AB)	■
● Crystal Golden Shadow M HF (001 GSHA)	■
● Crystal Silver Shade M HF (001 SSHA)	■
Color Effects	
Metallic Effects	
● Jet Hematite M HF (280 HEM)	■

Flat Backs Hotfix

2204 Pure Leaf Flat Back

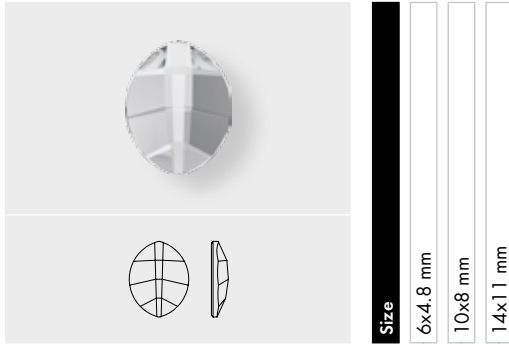

Crystal	6x4.8 mm	10x8 mm	14x11 mm
Crystal M HF (001)	■	■	■
Colors			
Plain Colors			
Amethyst M HF (204)	■	■	■
Dark Moss Green M HF (260)	■	■	■
Emerald M HF (205)	■	■	■
Jet M HF (280)	■	■	■
Light Siam M HF (227)	■	■	■
Peridot M HF (214)	■	■	■
Crystal Effects			
Transparent Effects			
Crystal AB M HF (001 AB)	■	■	■
Crystal Blue Shade M HF (001 BLSH)	■	■	■
Crystal Golden Shadow M HF (001 GSHA)	■	■	■
Crystal Luminous Green M HF (001 LUMG)	■	■	■
Crystal Silver Night M HF (001 SINI)	■	■	■

2300 Drop Flat Back



Crystal	8x4.8 mm
Crystal M HF (001)	■
Colors	
Plain Colors	
Jet M HF (280)	■
Crystal Effects	
Transparent Effects	
Crystal AB M HF (001 AB)	■
Crystal Golden Shadow M HF (001 GSHA)	■
Color Effects	
Metallic Effects	
Jet Hematite M HF (280 HEM)	■

Flat Backs Hotfix

2400 Square Flat Back

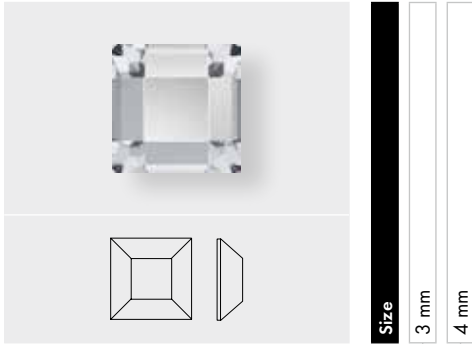

Size
3 mm
4 mm

- Crystal**
- Crystal M HF (001)
- Colors**
- Plain Colors
- Jet M HF (280)
- Crystal Effects**
- Transparent Effects
- Crystal AB M HF (001 AB)
- Crystal Golden Shadow M HF (001 GSHA)
- Color Effects**
- Metallic Effects
- Jet Hematite M HF (280 HEM)

2483 Classic Square Flat Back

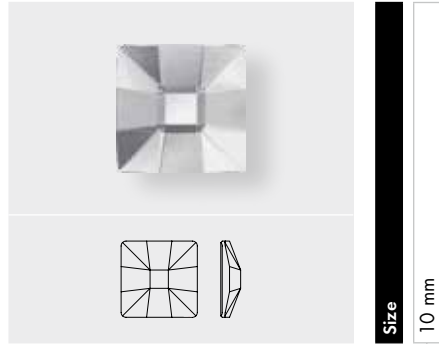

Size
10 mm

- Crystal**
- Crystal M HF (001)
- Colors**
- Plain Colors
- Black Diamond M HF (215)
- Crystal Effect**
- Transparent Effects
- Crystal Golden Shadow M HF (001 GSHA)

2493 Chessboard Flat Back

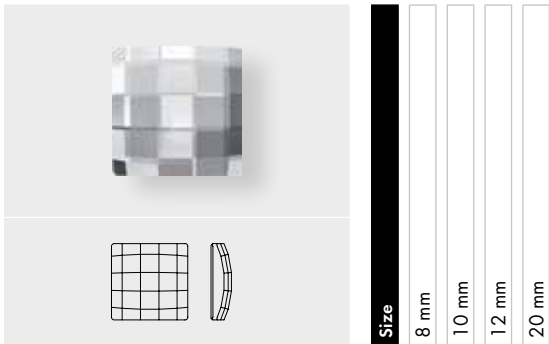

Size
8 mm
10 mm
12 mm
20 mm

- Crystal**
- Crystal M HF (001)
- Colors**
- Plain Colors
- Jet M HF (280)
- Crystal Effects**
- Crystal AB M HF (001 AB)
- Crystal Golden Shadow M HF (001 GSHA)
- Crystal Patina**
- Crystal Black Patina M HF (001 BLAPA)
- Crystal Gold Patina M HF (001 GOLPA)
- Crystal Rose Patina M HF (001 ROSPA)
- Crystal Silver Patina M HF (001 SILPA)
- Crystal White Patina M HF (001 WHIPA)

2510 Baguette Flat Back



Size
5x2.5 mm

- Crystal**
- Crystal M HF (001)
- Colors**
- Plain Colors
- Jet M HF (280)
- Crystal Effects**
- Transparent Effects
- Crystal AB M HF (001 AB)
- Color Effects**
- Metallic Effects
- Jet Hematite M HF (280 HEM)

Flat Backs Hotfix

2520 Cosmic Flat Back



Size

- 8x6 mm
- 10x8 mm
- 14x10 mm

Crystal

- Crystal M HF (001)

2555 Cosmic Baguette Flat Back

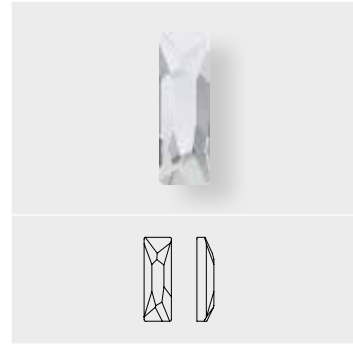

Size

- 8x2.6 mm
- 12x4 mm
- 15x5 mm

Crystal

- Crystal M HF (001)

Colors

Plain Colors

- Jet M HF (280)

Crystal Effects

Transparent Effects

- Crystal AB M HF (001 AB)
- Crystal Golden Shadow M HF (001 GSHA)
- Crystal Silver Shade M HF (001 SSHA)

2585 Graphic Flat Back



Size

- 8 mm
- 10 mm
- 14 mm

Crystal

- Crystal M HF (001)

Colors

Plain Colors

- Denim Blue M HF (266)

2610 Rectangle Flat Back



Size

- 6x4 mm

Crystal

- Crystal M HF (001)

Color Effects

Metallic Effects

- Jet Hematite M HF (280 HEM)

Flat Backs Hotfix

2611 Solaris Flat Back

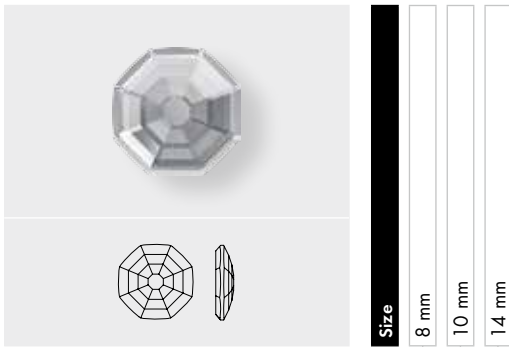

Size
8 mm
10 mm
14 mm

Crystal			
Crystal M HF (001)	■	■	■
Colors			
Plain Colors			
Aquamarine M HF (202)	■	■	■
Jet M HF (280)	■	■	■
Light Rose M HF (223)	■	■	■
Crystal Effects			
Transparent Effects			
Crystal AB M HF (001 AB)	■	■	■
Crystal Golden Shadow M HF (001 GSHA)	■	■	■
Crystal Luminous Green M HF (001 LUMG)	■	■	■
Crystal Silver Night M HF (001 SINI)	■	■	■
Metallic Effects			
Crystal Iridescent Green M HF (001 IRIG)	■	■	■

2611/G Solaris Flat Back partly frosted

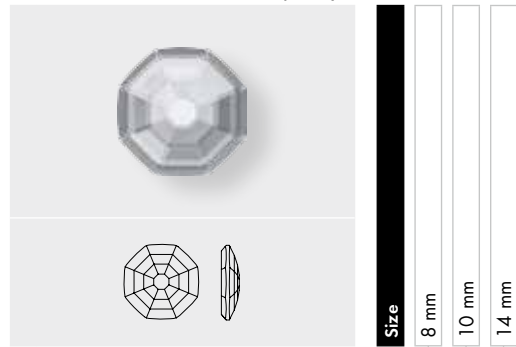

Size
8 mm
10 mm
14 mm

Crystal			
Crystal M HF (001)	■	■	■
Colors			
Plain Colors			
Aquamarine M HF (202)	■	■	■
Jet M HF (280)	■	■	■
Light Rose M HF (223)	■	■	■
Crystal Effects			
Transparent Effects			
Crystal AB M HF (001 AB)	■	■	■
Crystal Golden Shadow M HF (001 GSHA)	■	■	■
Crystal Luminous Green M HF (001 LUMG)	■	■	■
Crystal Silver Night M HF (001 SINI)	■	■	■
Metallic Effects			
Crystal Iridescent Green M HF (001 IRIG)	■	■	■

Flat Backs Hotfix

2708 Molecule Flat Back

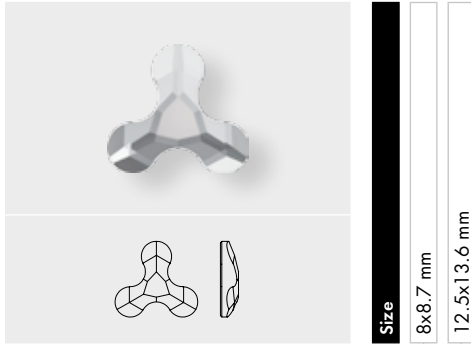

Size
8x8.7 mm
12.5x13.6 mm

- Crystal**
- Crystal M HF (001)
- Colors**
- Plain Colors**
- Amethyst M HF (204)
- Blue Zircon M HF (229)
- Dark Moss Green M HF (260)
- Denim Blue M HF (266)
- Fuchsia M HF (502)
- Jet M HF (280)
- Light Silk M HF (261)
- Light Turquoise M HF (263)
- Crystal Effects**
- Transparent Effects**
- Crystal AB M HF (001 AB)
- Crystal Antique Pink M HF (001 ANTP)
- Crystal Blue Shade M HF (001 BLSH)
- Crystal Golden Shadow M HF (001 GSHA)
- Crystal Silver Night M HF (001 SINI)
- Metallic Effects**
- Crystal Iridescent Green M HF (001 IRIG)
- Crystal Rose Gold M HF (001 ROGL)

2709 Rhombus Flat Back

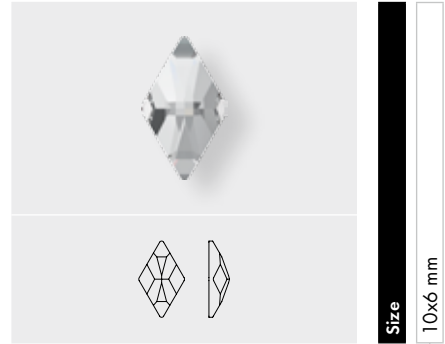

Size
10x6 mm

- Crystal**
- Crystal M HF (001)
- Colors**
- Plain Colors**
- Black Diamond M HF (215)
- Jet M HF (280)
- Light Siam M HF (227)
- Crystal Effects**
- Transparent Effects**
- Crystal AB M HF (001 AB)
- Crystal Golden Shadow M HF (001 GSHA)

Flat Backs Hotfix

2711 Triangle Flat Back

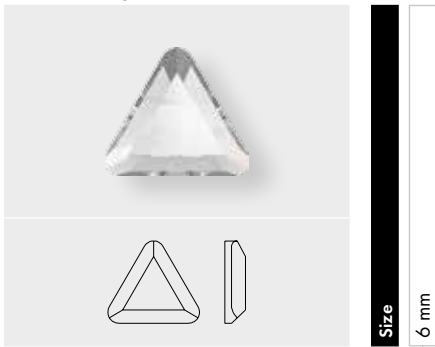

Size
6 mm

- Crystal**
- Crystal M HF (001)
- Colors**
- Plain Colors
- Jet M HF (280)
- Crystal Effects**
- Transparent Effects
- Crystal AB M HF (001 AB)
- Color Effects**
- Metallic Effects**
- Jet Hematite M HF (280 HEM)

2716 Rivoli Triangle Flat Back

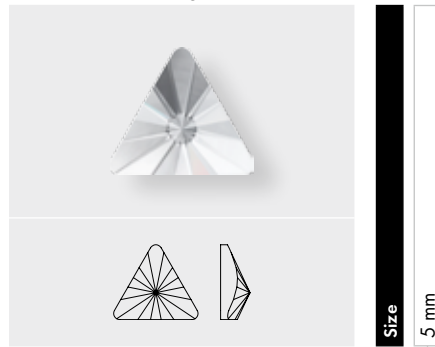

Size
5 mm

- Crystal**
- Crystal M HF (001)
- Crystal Effect**
- Transparent Effects
- Crystal AB M HF (001 AB)

2720 Cosmic Delta Flat Back

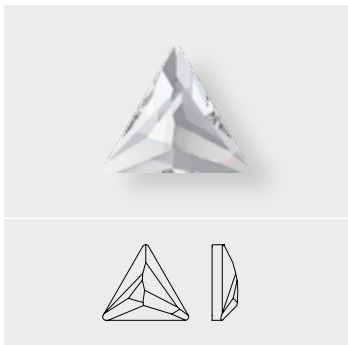

Size
7.5 mm
9 mm
12.5 mm

- Crystal**
- Crystal M HF (001)
- Colors**
- Plain Colors
- Jet M HF (280)
- Crystal Effects**
- Transparent Effects
- Crystal AB M HF (001 AB)
- Crystal Silver Shade M HF (001 SSHA)

2728 Marguerite Flat Back

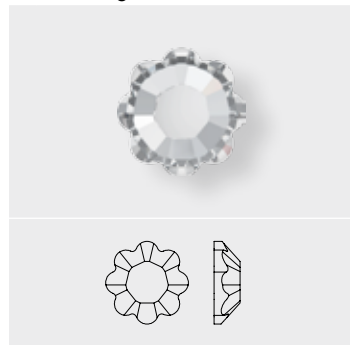

Size
SS 10
SS 16
SS 20
SS 34

- Crystal**
- Crystal M HF (001)
- Crystal Effect**
- Transparent Effects
- Crystal AB M HF (001 AB)

Flat Backs Hotfix

2770 Wing Flat Back

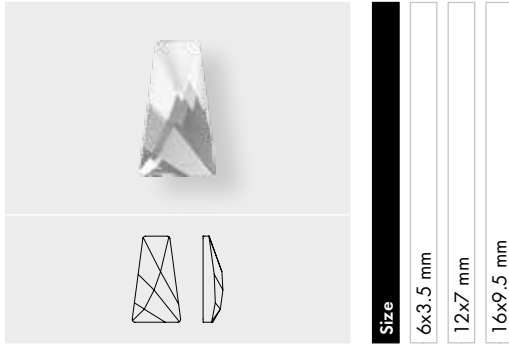

Size
 6x3.5 mm
 12x7 mm
 16x9.5 mm

- Crystal**
- Crystal M HF (001)
- Colors**
- Plain Colors**
- Black Diamond M HF (215)
- Jet M HF (280)
- Crystal Effects**
- Transparent Effects**
- Crystal AB M HF (001 AB)
- Crystal Golden Shadow M HF (001 GSHA)

2788 Wave Flat Back

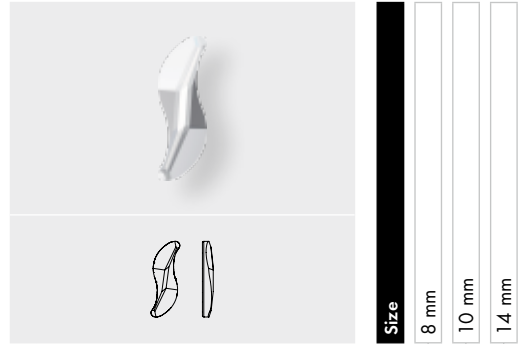

Size
 8 mm
 10 mm
 14 mm

- Crystal**
- Crystal M HF (001)
- Crystal Effects**
- Transparent Effects**
- Crystal AB M HF (001 AB)
- Crystal Blue Shade M HF (001 BLSH)

2797 Diamond Leaf Flat Back

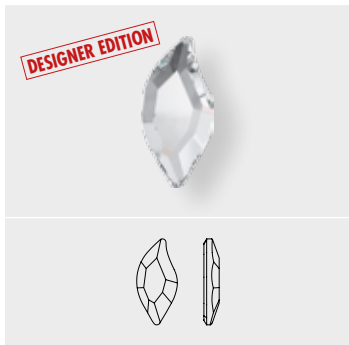

Size
 8x4 mm

- Crystal**
- Crystal M HF (001)
- Crystal Effect**
- Transparent Effects**
- Crystal AB M HF (001 AB)

Flat Backs Hotfix

2808 Heart Flat Back

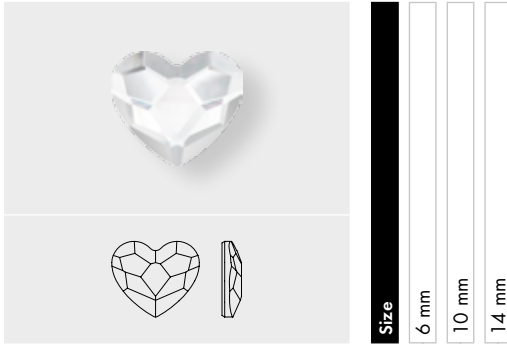

Size
6 mm
10 mm
14 mm

Crystal	6 mm	10 mm	14 mm
Crystal M HF (001)	■	■	■
Colors			
Plain Colors			
Dark Moss Green M HF (260)	■	■	■
Denim Blue M HF (266)	■	■	■
Fuchsia M HF (502)	■	■	■
Jet M HF (280)	■	■	■
Light Siam M HF (227)	■	■	■
Light Silk M HF (261)	■	■	■
Rosaline M HF (508)	■	■	■
Crystal Effects			
Transparent Effects			
Crystal AB M HF (001 AB)	■	■	■
Crystal Antique Pink M HF (001 ANTP)	■	■	■
Crystal Astral Pink M HF (001 API)	■	■	■
Crystal Golden Shadow M HF (001 GSHA)	■	■	■
Metallic Effects			
Crystal Rose Gold M HF (001 ROGL)	■	■	■
Crystal Patina			
Crystal Black Patina M HF (001 BLAPA)	■	■	■
Crystal Gold Patina M HF (001 GOLPA)	■	■	■
Crystal Rose Patina M HF (001 ROSPA)	■	■	■
Crystal Silver Patina M HF (001 SILPA)	■	■	■
Crystal White Patina M HF (001 WHIPA)	■	■	■

2816 Rivoli Star Flat Back

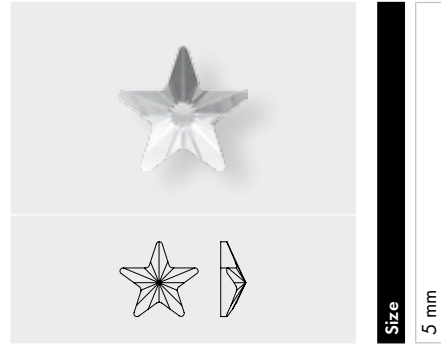

Size
5 mm

Crystal	5 mm
Crystal M HF (001)	■
Colors	
Plain Colors	
Jet M HF (280)	■
Crystal Effects	
Transparent Effects	
Crystal AB M HF (001 AB)	■
Color Effects	
Metallic Effects	
Jet Hematite M HF (280 HEM)	■

Flat Backs Hotfix

2817 Star Flat Back

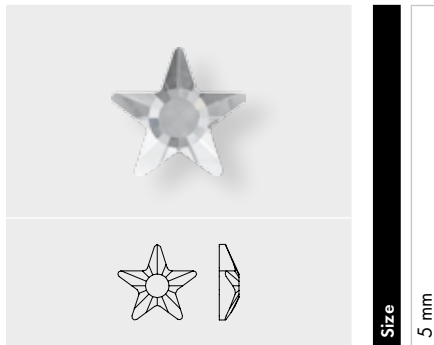

- Crystal**
- Crystal M HF (001)
- Colors**
- Plain Colors**
- Denim Blue M HF (266)
- Jet M HF (280)
- Rose Peach M HF (262)
- Crystal Effects**
- Transparent Effects**
- Crystal AB M HF (001 AB)
- Crystal Golden Shadow M HF (001 GSHA)
- Crystal Silver Night M HF (001 SINI)
- Metallic Effects**
- Crystal Iridescent Green M HF (001 IRIG)
- Crystal Rose Gold M HF (001 ROGL)
- Color Effects**
- Metallic Effects**
- Jet Hematite M HF (280 HEM)

2826 Rivoli Snowflake Flat Back

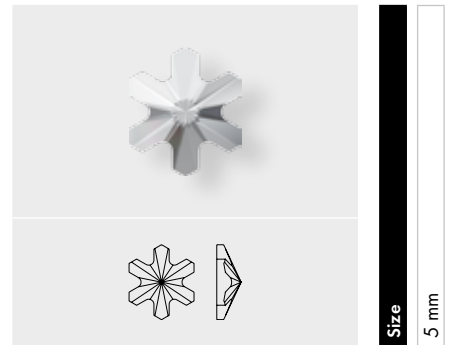

- Crystal**
- Crystal M HF (001)
- Crystal Effect**
- Transparent Effects**
- Crystal AB M HF (001 AB)

Flat Backs Hotfix

2855 Butterfly Flat Back

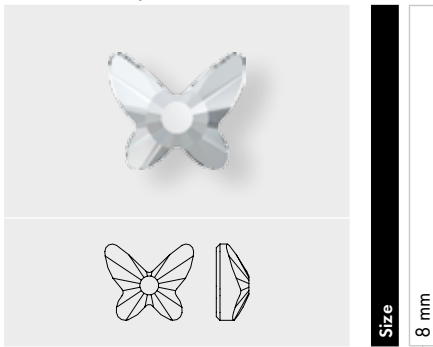

- Crystal**
- Crystal M HF (001)
- Colors**
- Plain Colors**
- Amethyst M HF (204)
- Denim Blue M HF (266)
- Jet M HF (280)
- Light Rose M HF (223)
- Rose Peach M HF (262)
- Crystal Effects**
- Transparent Effects**
- Crystal AB M HF (001 AB)
- Crystal Golden Shadow M HF (001 GSHA)
- Crystal Luminous Green M HF (001 LUMG)
- Crystal Silver Night M HF (001 SINI)

2855/G Butterfly Flat Back fully frosted

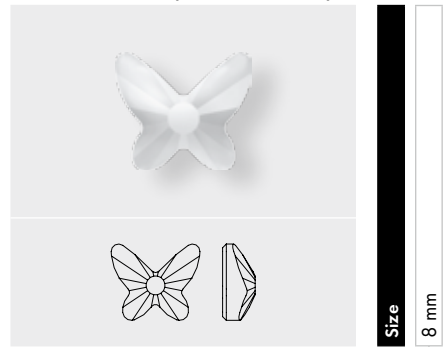

- Crystal**
- Crystal M HF FF (001)
- Colors**
- Plain Colors**
- Amethyst M HF FF (204)
- Denim Blue M HF FF (266)
- Light Rose M H F FF (223)
- Rose Peach M HF FF (262)

Flat Backs Hotfix

2858 Bow Tie Flat Back



	6x4.5 mm	9x6.5 mm	12x8.5 mm
Crystal			
Crystal M HF (001)	■	■	■
Colors			
Plain Colors			
Denim Blue M HF (266)	■	■	■
Jet M HF (280)	■	■	■
Light Amethyst M HF (212)	■	■	■
Light Siam M HF (227)	■	■	■
Tangerine M HF (259)	■	■	■
Vintage Rose M HF (319)	■	■	■
Opal Colors			
White Opal M HF (234)	■	■	■
Crystal Effects			
Transparent Effects			
Crystal AB M HF (001 AB)	■	■	■
Crystal Golden Shadow M HF (001 GSHA)	■	■	■
Crystal Luminous Green M HF (001 LUMG)	■	■	■
Crystal Silver Night M HF (001 SINII)	■	■	■
Metallic Effects			
Crystal Iridescent Green M HF (001 IRIG)	■	■	■

Flat Backs Hoffix

PRODUCT DETAILS

Article Size	Packing Unit = Minimum Order Quantity in Pieces	Average Net Weight in Gram per Packing Unit Crystal (001)	Average Gross Weight in Gram per Packing Unit Crystal (001)
2000 A HF			
SS 3	1,440	1.8	12.7
2035 M HF			
6 mm	360	27.1	34.8
10 mm	192	56.2	88.0
14 mm	96	88.4	109.9
20 mm	40	82.0	121.4
2037 M HF			
8 mm	240	14.48	23.58
14 mm	72	12.05	39.99
17 mm	72	27.72	52.20
2038 A HF			
SS 5	1,440	4.18	12.15
SS 6	1,440	5.45	17.66
SS 8	1,440	9.96	18.22
SS 10	1,440	15.54	24.33
2038/B			
SS 8	1,440	9.96	18.22
SS 10	1,440	15.54	24.33
SS 12	1,440	21.59	30.36
SS 16	1,440	39.09	47.11
SS 20	1,440	71.98	79.58
2078 A HF			
SS 12	1,440	21.59	30.36
SS 16	1,440	39.09	47.11
SS 20	1,440	71.98	79.58
SS 30	288	34.56	63.02
SS 34	144	25.92	48.59
SS 40	144	43.2	66.87
SS 48	96	61.44	87.41
2080/4 HF			
SS 10	1,440	17.1	28.3
SS 16	1,440	43.4	54.9
SS 34	144	23.2	34.1
2200 M HF			
8x4 mm	360	24.8	35.8
2204 M HF			
6x4.8 mm	360	27.237	36.368
10x8 mm	144	31.450	53.332
14x11 mm	108	52.618	74.012
2300 M HF			
8x4.8 mm	360	41.9	51.0
2400 M HF			
3 mm	1,440	25.3	36.8
4 mm	720	30.0	41.0
2483 M HF			
10 mm	144	89.19	119.00
2493 M HF			
8 mm	216	72.3	91.8
10 mm	144	84.4	106.1
12 mm	96	96.4	127.8
20 mm	24	108.5	137.9

Flat Backs Hotfix

Article Size	Packing Unit = Minimum Order Quantity in Pieces	Average Net Weight in Gram per Packing Unit Crystal (001)	Average Gross Weight in Gram per Packing Unit Crystal (001)
2510 M HF 5x2.5 mm	720	23.2	32.3
2520 M HF 8x6 mm	288	50.81	80.25
10x8 mm	144	72.32	94.20
14x10 mm	144	119.32	145.24
2555 M HF 8x2.6 mm	240	18.4	27.5
12x4 mm	144	28.8	33.6
15x5 mm	72	28.9	46.0
2585 M HF 8 mm	288	48.21	68.08
10 mm	288	72.32	104.28
14 mm	144	106.06	145.52
2610 M HF 6x4 mm	360	23.5	34.3
2611 M HF 8 mm	144	29.400	68.08
10 mm	216	93.623	104.28
14 mm	48	42.336	145.52
2611/G M HF 8 mm	144	29.400	68.08
10 mm	216	93.623	104.28
14 mm	48	42.336	145.52
2708 M HF 8x8.7 mm	288	28.063	57.335
12.5x13.6 mm	96	49.318	69.271
2709 M HF 10x6 mm	288	28.93	67.23
2711 M HF 6 mm	360	29.7	40.7
2716 M HF 5 mm	720	35.78	75.11
2720 M HF 7.5 mm	240	27.9	37.0
9 mm	180	45.1	54.2
12.5 mm	144	71.1	87.1
2728 M HF SS 10	1,440	14.1	24.6
SS 16	1,440	38.0	48.8
SS 20	1,440	65.7	76.5
SS 34	144	26.5	37.5
2770 M HF 6x3.5 mm	1,440	60.3	70.3
12x7 mm	192	49.8	98.4
16x9.5 mm	72	48.8	77.7
2788 M HF 8 mm	288	7.54	18.43
10 mm	216	10.54	37.75
14 mm	144	16.99	45.07

Flat Backs Hotfix

09 Flat Backs Hotfix

Article Size	Packing Unit = Minimum Order Quantity in Pieces	Average Net Weight in Gram per Packing Unit Crystal (001)	Average Gross Weight in Gram per Packing Unit Crystal (001)
2797 M HF 8x4 mm	240	14.9	24.0
2808 M HF 6 mm	288	19.772	28.919
10 mm	144	38.823	55.902
14 mm	96	56.448	86.849
2816 M HF 5 mm	720	23.56	30.69
2817 M HF 5 mm	720	21.915	31.063
2826 M HF 5 mm	720	23.06	30.07
2855 M HF 8 mm	216	46.79	55.93
2855/G M HF 8 mm	216	46.79	55.93
2858 M HF 6x4.5 mm	240	12.51	21.66
9x6.5 mm	144	23.39	44.05
12x8.5 mm	96	28.71	49.79

Sew-on Articles

Sew-on Articles are loose crystals that can be easily sewn either by hand, or with a standard domestic or industrial embroidery sewing machine onto any type of textile or accessory. Sew-on Articles come in two- or three-hole varieties, including round, oval, and triangle holes for use in a wide range of decorative applications for fine embroidery or even jewelry. Lochrosen are crystals with just one hole. Sew-on Articles have rounded edges on the hole entry and exit areas to guarantee thread protection.

The assortment offers a great variety of colors and effects to turn textiles and fashion accessories into bespoke luxury items.

Sew-on Articles

SUMMARY

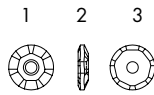

3129 P288
7 mm

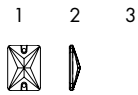

3250
18x13, 25x18 mm

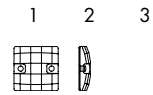

3293
12, 20 mm



3188
3, 4, 5, 6, 7, 8, 10 mm



3251
18x9, 30x15 mm



3400
6, 8, 10 mm



3200
10, 12, 14, 16, 18 mm



3254
20x9, 30x14 mm



3700
6, 8, 10, 12, 14 mm



3200/G
10, 12, 14, 16, 18 mm



3255
18x6, 26x8.5 mm



3708
8x8.7, 12.5x13.6 mm



3210
10x7, 16x11, 24x17 mm



3256
14x8.5, 19x11.5 mm



3220
10, 14, 20 mm



3257
19x13, 27x19 mm



3221
18, 28 mm



3258
12x8.5, 16x11.5 mm



3223
12x6, 18x9 mm



3261
18, 28 mm



3224
14x11, 23x18 mm



3265
20x16, 26x21 mm



3230
12x7, 18x10.5,
28x17 mm



3267
18x10 mm



3231
18x11, 23x14 mm



3270
16, 22 mm



3240
16, 22 mm



3288
8, 10, 12 mm

Sew-on Articles

3129 P288

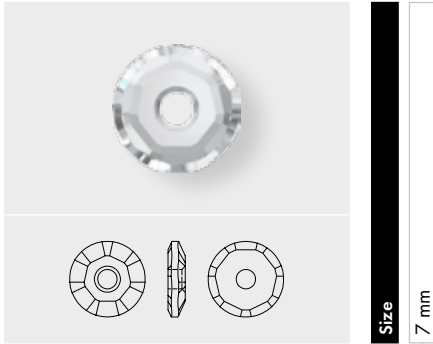

Size
7 mm

Crystal	
Crystal (001)	■
Crystal M (001)	■
Colors	
Plain Colors	
Aquamarine (202)	■
Black Diamond (215)	■
Jet (280)	■
Jonquil (213)	■
Light Amethyst (212)	■
Light Colorado Topaz (246)	■
Light Rose (223)	■
Light Siam (227)	■
Crystal Effects	
Transparent Effects	
Crystal AB (001 AB)	■
Color Effects	
Metallic Effects	
Jet Hematite (280 HEM)	■

3188 XIRIUS Lochrose

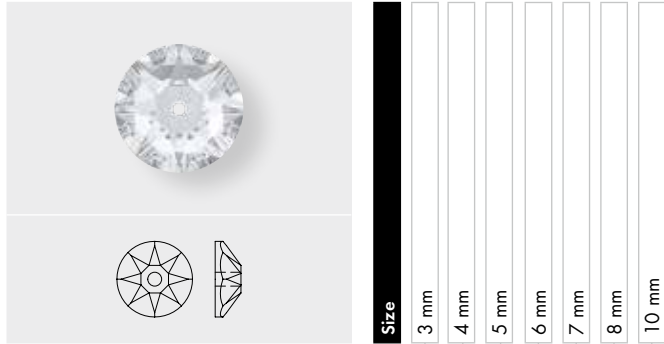

Size
3 mm
4 mm
5 mm
6 mm
7 mm
8 mm
10 mm

Crystal	
Crystal (001)	■ ■ ■
Crystal F (001)	■ ■ ■ ■ ■ ■ ■
Colors	
Plain Colors	
Amethyst F (204)	■ ■ ■
Black Diamond F (215)	■ ■ ■
Dark Moss Green F (260)	■ ■ ■
Denim Blue F (266)	■ ■ ■
Emerald F (205)	■ ■ ■
Fuchsia F (502)	■ ■ ■
Jet (280)	■ ■ ■
Light Colorado Topaz F (246)	■ ■ ■
Light Peach F (362)	■ ■ ■
Light Siam F (227)	■ ■ ■
Light Silk F (261)	■ ■ ■
Light Turquoise F (263)	■ ■ ■
Tangerine F (259)	■ ■ ■
Crystal Effects	
Transparent Effects	
Crystal AB F (001 AB)	■ ■ ■ ■ ■ ■ ■
Crystal Astral Pink F (001 API)	■ ■ ■
Crystal Blue Shade F (001 BLSH)	■ ■ ■
Crystal Golden Shadow F (001 GSHA)	■ ■ ■
Crystal Lilac Shadow F (001 LISH)	■ ■ ■
Crystal Luminous Green F (001 LUMG)	■ ■ ■
Crystal Moonlight F (001 MOL)	■ ■ ■
Crystal Silver Night (001 SINI)	■ ■ ■
Crystal Silver Shade F (001 SSHA)	■ ■ ■
Metallic Effects	
Crystal Iridescent Green F (001 IRIG)	■ ■ ■
Color Effects	
Metallic Effects	
Jet Hematite (280 HEM)	■ ■ ■

Sew-on Articles

3200 Rivoli Sew-on Stone

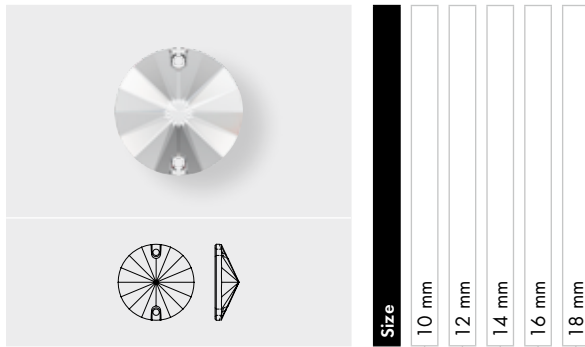

	10 mm	12 mm	14 mm	16 mm	18 mm
Crystal					
Crystal F (001)	■	■	■	■	■
Colors					
Plain Colors					
Black Diamond F (215)	■	■	■		
Fuchsia F (502)	■				
Jet (280)	■	■	■		
Light Colorado Topaz F (246)	■	■			
Light Rose F (223)	■				
Light Siam F (227)	■	■	■		
Light Silk F (261)	■	■	■		
Light Turquoise F (263)	■	■	■		
Topaz F (203)	■				
Crystal Effects					
Transparent Effects					
Crystal AB F (001 AB)	■	■	■	■	■
Crystal Astral Pink F (001 API)	■	■	■		
Crystal Golden Shadow F (001 GSHA)	■	■	■		
Crystal Lilac Shadow F (001 LISH)	■	■	■		
Crystal Satin F (001 SAT)	■	■			
Metallic Effects					
Crystal Iridescent Green F (001 IRIG)	■	■	■		
Crystal Rose Gold F (001 ROGL)	■	■	■		
Color Effects					
Metallic Effects					
Jet Hematite (280 HEM)	■	■	■		

3200/G Rivoli Sew-on Stone partly frosted

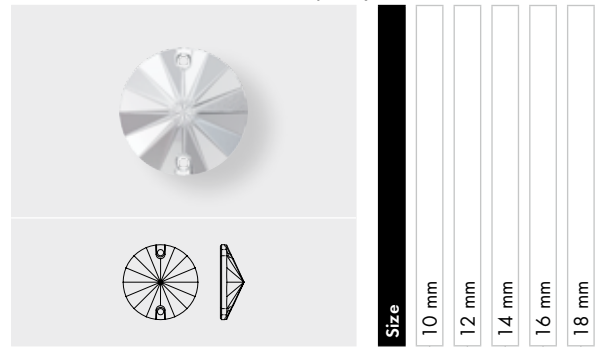

	10 mm	12 mm	14 mm	16 mm	18 mm
Crystal					
Crystal PF F (001)	■	■	■	■	■
Colors					
Plain Colors					
Amethyst PF F (204)		■	■	■	
Black Diamond PF F (215)		■	■	■	
Denim Blue PF F (266)		■	■	■	
Fuchsia PF F (502)		■	■		
Light Colorado Topaz PF F (246)		■	■	■	
Rose Peach PF F (262)		■	■	■	
Crystal Effects					
Transparent Effects					
Crystal AB PF F (001 AB)	■	■	■	■	■
Crystal Golden Shadow PF F (001 GSHA)		■	■	■	
Crystal Luminous Green PF F (001 LUMG)		■	■	■	

Sew-on Articles

3210 Oval Sew-on Stone

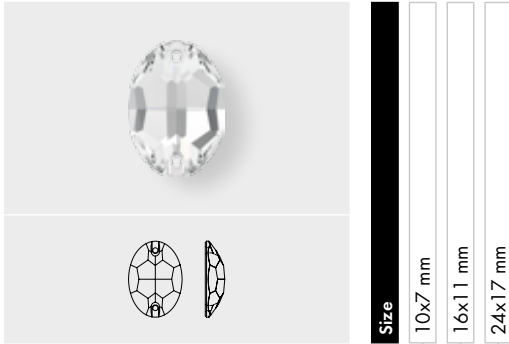

Size
10x7 mm
16x11 mm
24x17 mm

Crystal			
Crystal F (001)	■	■	■
Colors			
Plain Colors			
Light Colorado Topaz F (246)	■		
Light Turquoise F (263)	■	■	■
Crystal Blend Colors			
Crystal-Montana Blend (725)	■	■	
Crystal-Montana Blend F (725)	■	■	
Provence Lavender-Chrysolite Blend (726)	■	■	
Provence Lavender-Chrysolite Blend F (726)	■	■	
Crystal Effects			
Transparent Effects			
Crystal AB F (001 AB)	■	■	■
Crystal Astral Pink F (001 API)	■		
Crystal Blue Shade F (001 BLSH)	■	■	■
Crystal Patina			
Crystal Black Patina F (001 BLAPA)	■	■	■
Crystal Gold Patina F (001 GOLPA)	■	■	■
Crystal Rose Patina F (001 ROSPA)	■	■	■
Crystal Silver Patina F (001 SILPA)	■	■	■
Crystal White Patina F (001 WHIPA)	■	■	■

3220 Round Chessboard Sew-on Stone

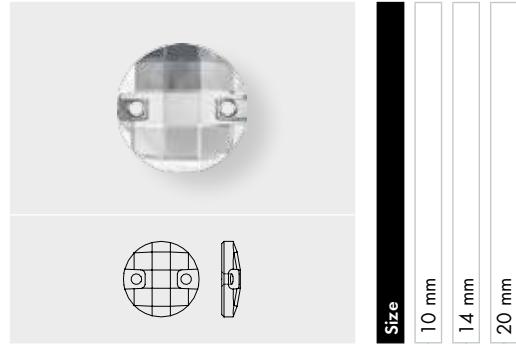

Size
10 mm
14 mm
20 mm

Crystal			
Crystal F (001)	■	■	■
Colors			
Plain Colors			
Blue Zircon F (229)	■	■	■
Dark Moss Green F (260)	■	■	■
Jet (280)	■	■	■
Crystal Effects			
Transparent Effects			
Crystal AB F (001 AB)	■	■	■
Crystal Antique Pink F (001 ANTP)	■	■	■
Crystal Blue Shade F (001 BLSH)	■	■	■
Crystal Golden Shadow F (001 GSHA)	■	■	■
Crystal Lilac Shadow F (001 LISH)	■	■	■
Crystal Silver Shade F (001 SSHA)	■	■	■
Metallic Effects			
Crystal Iridescent Green F (001 IRIG)	■	■	■
Crystal Patina			
Crystal Black Patina F (001 BLAPA)	■	■	■
Crystal Gold Patina F (001 GOLPA)	■	■	■
Crystal Rose Patina F (001 ROSPA)	■	■	■
Crystal Silver Patina F (001 SILPA)	■	■	■
Crystal White Patina F (001 WHIPA)	■	■	■

Sew-on Articles

3221 Twist Sew-on Stone

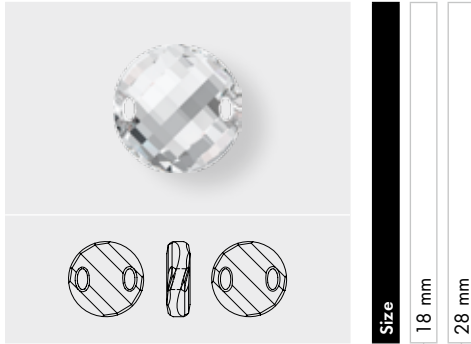

- Size**
18 mm
28 mm
- Crystal**
- Crystal F (001)
- Crystal Effects**
- Transparent Effects**
- Crystal Golden Shadow (001 GSHA)

3223 Navette Sew-on Stone

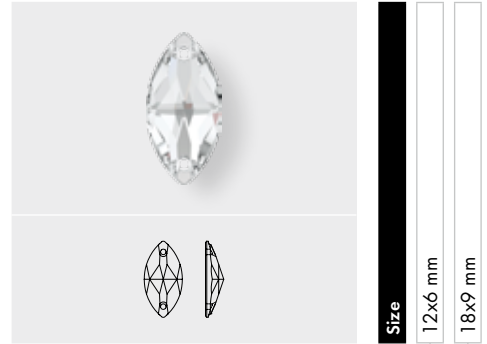

- Size**
12x6 mm
18x9 mm
- Crystal**
- Crystal F (001)
- Colors**
- Plain Colors**
- Jet (280)
- Crystal Effects**
- Transparent Effects**
- Crystal AB F (001 AB)
 - Crystal Golden Shadow F (001 GSHA)

3224 Pure Leaf Sew-on Stone

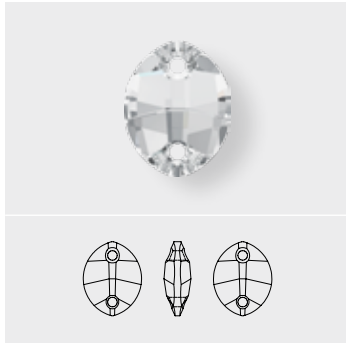

Size 14x11 mm

3224 Pure Leaf Sew-on Stone

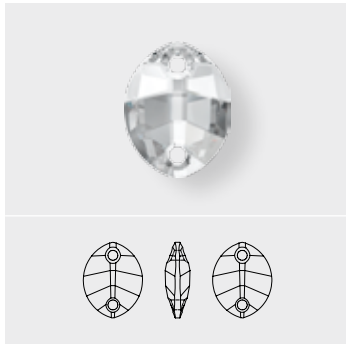

Size 23x18 mm

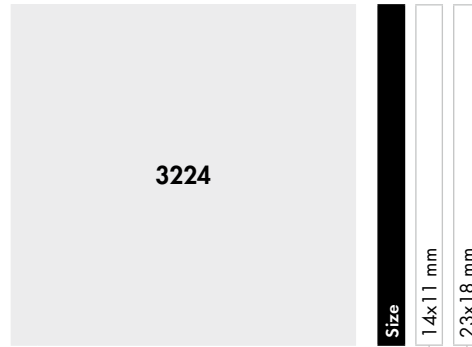

- 3224**
- Size**
14x11 mm
23x18 mm
- Crystal**
- Crystal (001)
 - Crystal F (001)
- Colors**
- Plain Colors**
- Amethyst (204)
 - Dark Moss Green (260)
 - Emerald (205)
 - Jet (280)
 - Peridot (214)
- Crystal Effects**
- Transparent Effects**
- Crystal AB (001 AB)
 - Crystal Blue Shade (001 BLSH)
 - Crystal Golden Shadow (001 GSHA)
 - Crystal Luminous Green (001 LUMG)
 - Crystal Red Magma (001 REDM)
 - Crystal Silver Night (001 SINI)

Sew-on Articles

3230 Drop Sew-on Stone

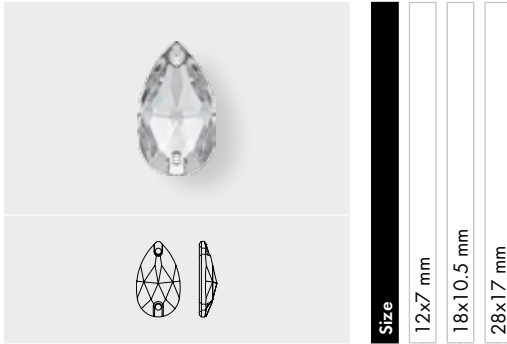

Size
12x7 mm
18x10.5 mm
28x17 mm

Crystal		
Crystal F (001)	■	■
Colors		
Plain Colors		
Blue Zircon F (229)	■	
Fuchsia F (502)	■	
Jet (280)	■	
Light Amethyst F (212)	■	
Light Colorado Topaz F (246)	■	
Light Sapphire F (211)	■	
Light Siam F (227)	■	
Light Turquoise F (263)	■	■
Rosaline F (508)	■	■
Crystal Blend Colors		
Crystal-Montana Blend (725)	■	■
Crystal-Montana Blend F (725)	■	■
Burgundy-Blue Zircon Blend (723)	■	■
Fern Green-Topaz Blend (724)	■	■
Provence Lavender-Chrysolite Blend (726)	■	■
Provence Lavender-Chrysolite Blend F (726)	■	■
Crystal Effects		
Transparent Effects		
Crystal AB F (001 AB)	■	■
Crystal Astral Pink F (001 API)	■	■
Crystal Blue Shade F (001 BLSH)	■	
Crystal Copper F (001 COP)	■	
Crystal Golden Shadow F (001 GSHA)	■	
Crystal Lilac Shadow F (001 LISH)	■	■
Crystal Luminous Green F (001 LUMG)	■	
Crystal Satin F (001 SAT)	■	■
Crystal Silver Night F (001 SINI)	■	

3231 Owllet Sew-on Stone

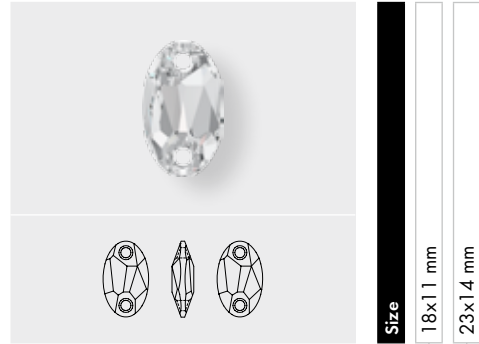

Size
18x11 mm
23x14 mm

Crystal		
Crystal (001)	■	
Crystal F (001)	■	■
Colors		
Plain Colors		
Jet (280)	■	■
Crystal Effects		
Transparent Effects		
Crystal Golden Shadow (001 GSHA)	■	■
Crystal Moonlight (001 MOL)	■	■

Sew-on Articles

3240 Square Sew-on Stone

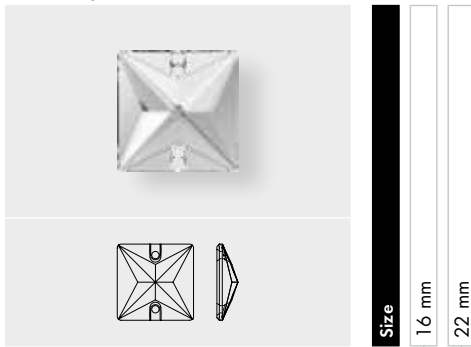

Size
16 mm
22 mm

- Crystal**
- Crystal F (001)
- Colors**
- Plain Colors**
- Jet (280)
- Crystal Effects**
- Transparent Effects**
- Crystal AB F (001 AB)
- Metallic Effects**
- Crystal Dorado F (001 DOR)
- Color Effects**
- Metallic Effects**
- Jet Hematite (280 HEM)

3250 Rectangle Sew-on Stone

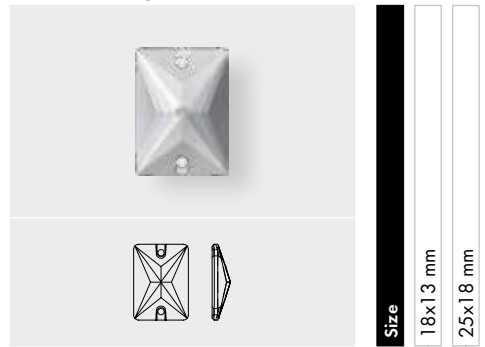

Size
18x13 mm
25x18 mm

- Crystal**
- Crystal F (001)
- Colors**
- Plain Colors**
- Jet (280)
- Crystal Effects**
- Transparent Effects**
- Crystal AB F (001 AB)

3251 Space Cut Sew-on Stone

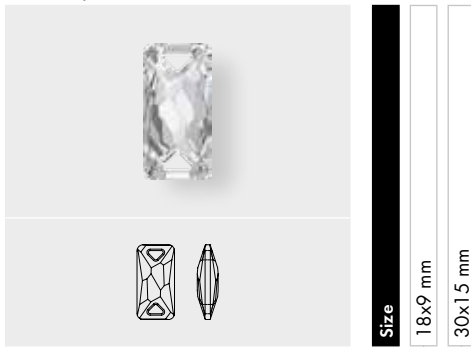

Size
18x9 mm
30x15 mm

- Crystal**
- Crystal F (001)
- Crystal Effects**
- Transparent Effects**
- Crystal Golden Shadow (001 GSHA)

3254 Diamond Leaf Sew-on Stone



Size
20x9 mm
30x14 mm

- Crystal**
- Crystal F (001)
- Colors**
- Plain Colors**
- Jet (280)
- Crystal Effects**
- Transparent Effects**
- Crystal Golden Shadow F (001 GSHA)
- Crystal Silver Shade F (001 SSHA)

Sew-on Articles

3255 Cosmic Baguette Sew-on Stone



Size

18x6 mm

26x8.5 mm

Crystal

Crystal F (001)

Colors

Plain Colors

Jet (280)

Crystal Effects

Transparent Effects

Crystal Golden Shadow F (001 GSHA)

Crystal Silver Shade F (001 SSHA)

3256 Galactic Sew-on Stone

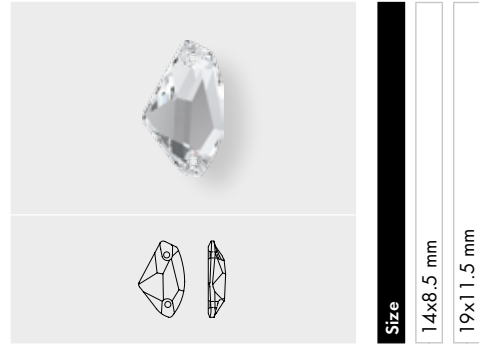

Size

14x8.5 mm

19x11.5 mm

Crystal

Crystal F (001)

Colors

Plain Colors

Jet (280)

Crystal Effects

Transparent Effects

Crystal Golden Shadow F (001 GSHA)

Crystal Silver Shade F (001 SSHA)

3257 Divine Rock Sew-on Stone

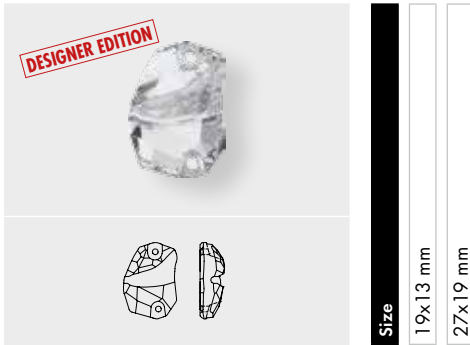

Size

19x13 mm

27x19 mm

Crystal

Crystal F (001)

3258 Bow Tie Sew-on Stone

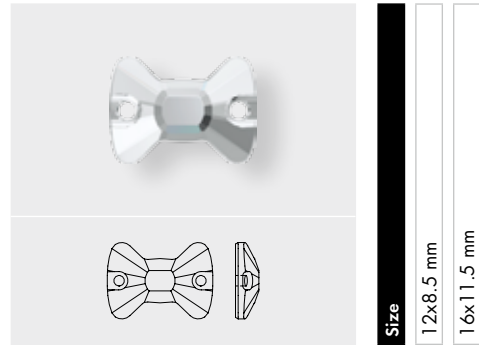

Size

12x8.5 mm

16x11.5 mm

Crystal

Crystal F (001)

Colors

Plain Colors

Denim Blue F (266)

Jet (280)

Light Amethyst F (212)

Light Siam F (227)

Vintage Rose F (319)

Crystal Effects

Transparent Effects

Crystal AB F (001 AB)

Crystal Golden Shadow F (001 GSHA)

Crystal Silver Night (001 SINI)

Metallic Effects

Crystal Iridescent Green F (001 IRIG)

Sew-on Articles

3261 Hexagon Sew-on Stone

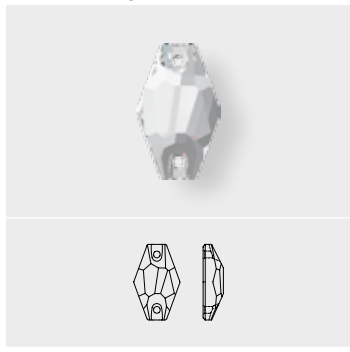

Size
18 mm
28 mm

Crystal
Crystal F (001)

3265 Cosmic Sew-on Stone

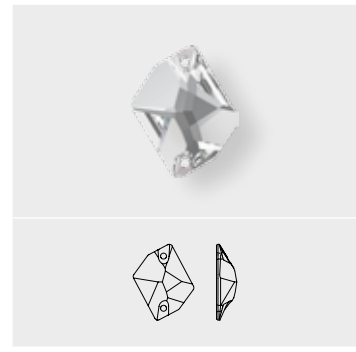

Size
20x16 mm
26x21 mm

Crystal
Crystal F (001)

Colors

Plain Colors
Jet (280)

Crystal Effects

Transparent Effects
Crystal AB F (001 AB)
Crystal Golden Shadow F (001 GSHA)
Crystal Silver Shade F (001 SSHA)

3267 De-Art Sew-on Stone



Size
18x10 mm

Crystal
Crystal F (001)

Colors

Plain Colors
Jet (280)

Color Effects

Metallic Effects
Jet Hematite (280 HEM)

3270 Triangle Sew-on Stone

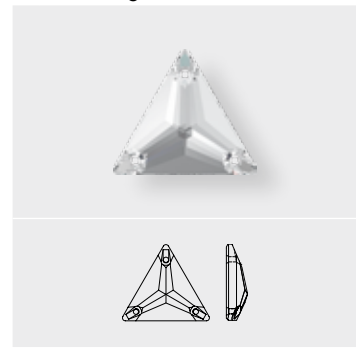

Size
16 mm
22 mm

Crystal
Crystal F (001)

Colors

Plain Colors
Jet (280)

Crystal Effects

Transparent Effects
Crystal AB F (001 AB)

Sew-on Articles

3288 XIRIUS Sew-on Stone

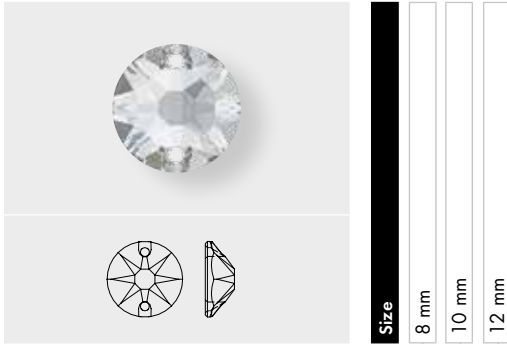

Size
8 mm
10 mm
12 mm

Crystal

Crystal F (001)

Colors

Plain Colors

Amethyst F (204)

Black Diamond F (215)

Dark Moss Green F (260)

Denim Blue F (266)

Emerald F (205)

Fuchsia F (502)

Jet (280)

Light Colorado Topaz F (246)

Light Peach F (362)

Light Siam F (227)

Light Silk F (261)

Light Turquoise F (263)

Tangerine F (259)

Crystal Effects

Transparent Effects

Crystal AB F (001 AB)

Crystal Astral Pink F (001 API)

Crystal Blue Shade F (001 BLSH)

Crystal Golden Shadow F (001 GSHA)

Crystal Lilac Shadow F (001 LISH)

Crystal Luminous Green F (001 LUMG)

Crystal Moonlight F (001 MOL)

Crystal Silver Night (001 SINI)

Crystal Silver Shade F (001 SSHA)

Metallic Effects

Crystal Iridescent Green F (001 IRIG)

Color Effects

Metallic Effects

Jet Hematite (280 HEM)

3293 Chessboard Sew-on Stone

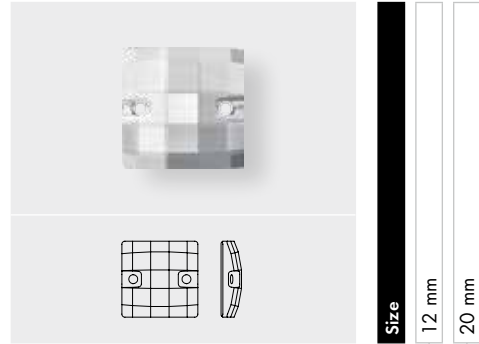

Size
12 mm
20 mm

Crystal

Crystal F (001)

Colors

Plain Colors

Jet (280)

Sew-on Articles

3400 Square Lochrose

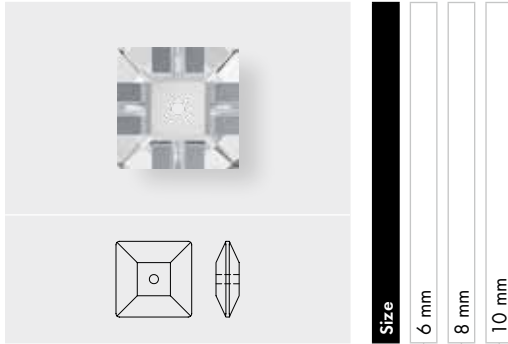

Crystal		6 mm	8 mm	10 mm
Crystal F (001)		■	■	■
Colors				
Plain Colors				
Jet (280)		■		
Light Colorado Topaz F (246)		■		
Crystal Effects				
Transparent Effects				
Crystal AB F (001 AB)		■		
Crystal Astral Pink F (001 API)		■		
Crystal Satin F (001 SAT)		■		

3700 Marguerite Lochrose

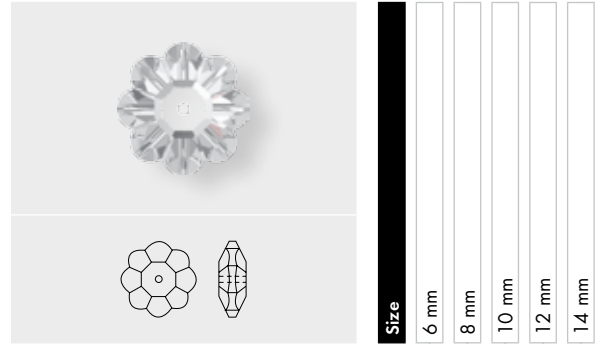

Crystal		6 mm	8 mm	10 mm	12 mm	14 mm
Crystal (001)		■	■	■	■	■
Crystal F (001)		■	■	■	■	■
Colors						
Plain Colors						
Dark Moss Green (260)		■	■	■	■	■
Emerald (205)		■	■	■	■	■
Fern Green (291)		■	■	■	■	■
Jet (280)		■	■	■		
Light Siam (227)		■	■	■	■	■
Peridot (214)		■	■	■	■	■
Crystal Effects						
Transparent Effects						
Crystal AB (001 AB)		■	■	■	■	■
Crystal Vitrail Medium (001 VM)		■	■	■	■	■

Sew-on Articles

3708 Molecule Lochrose

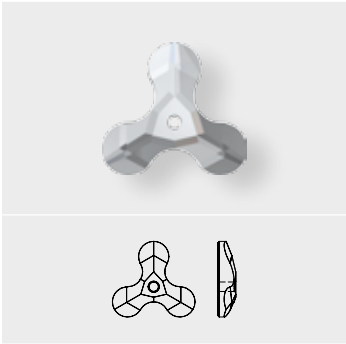

Size

8x8.7 mm

12.5x13.6 mm

Crystal

Crystal F (001)

Colors

Plain Colors

Amethyst F (204)

Blue Zircon F (229)

Dark Moss Green F (260)

Denim Blue F (266)

Fuchsia F (502)

Jet (280)

Light Silk F (261)

Light Turquoise F (263)

Crystal Effects

Transparent Effects

Crystal AB F (001 AB)

Crystal Antique Pink F (001 ANTP)

Crystal Blue Shade F (001 BLSH)

Crystal Golden Shadow F (001 GSHA)

Crystal Lilac Shadow F (001 LISH)

Crystal Silver Night F (001 SINI)

Metallic Effects

Crystal Iridescent Green F (001 IRIG)

Crystal Rose Gold F (001 ROGL)

Sew-on Articles

PRODUCT DETAILS

Article Size	Packing Unit = Minimum Order Quantity in Pieces	Average Net Weight in Gram per Packing Unit Crystal (001)	Average Gross Weight in Gram per Packing Unit Crystal (001)
3129 P288			
7 mm	2,880	291.28	473.20
3188			
3 mm	1,440	21.46	29.95
4 mm	1,440	47.55	56.03
5 mm	720	43.2	51.68
6 mm	360	35.69	44.05
7 mm	144	22.19	30.67
8 mm	144	33.22	41.71
10 mm	96	44.16	44.16
3200			
10 mm	72	26.1	44.6
12 mm	72	54.9	74
14 mm	72	77.2	100.7
16 mm	72	115.8	139.4
18 mm	48	117.17	199.46
3200/G			
10 mm	72	19.473	42.107
12 mm	72	54.9	74
14 mm	72	77.490	97.180
16 mm	72	116.243	136.080
18 mm	48	117.17	199.46
3210			
10x7 mm	72	18.1	37.9
16x11 mm	72	66.3	86.3
24x17 mm	24	72.5	97.9
3220			
10 mm	192	69.350	97.252
14 mm	96	88.704	120.234
20 mm	40	94.080	126.202
3221			
18 mm	72	174.8	198.5
28 mm	24	210.9	243.7
3223			
12x6 mm	48	13.1	34.2
18x9 mm	36	27.7	45.1
3224			
14x11 mm	108	77.112	103.058
23x18 mm	30	86.688	110.527
3230			
12x7 mm	96	29.7	47.0
18x10.5 mm	72	70.5	90.7
28x17 mm	24	72.1	97.5
3231			
18x11 mm	96	120.5	148.2
23x14 mm	36	96.4	126.9
3240			
16 mm	72	108.5	132.1
22 mm	24	88.0	139.6
3250			
18x13 mm	72	111.5	135.1
25x18 mm	24	84.4	130.7

Sew-on Articles

Article Size	Packing Unit = Minimum Order Quantity in Pieces	Average Net Weight in Gram per Packing Unit Crystal (001)	Average Gross Weight in Gram per Packing Unit Crystal (001)
3251			
18x9 mm	48	59.82	77.34
30x15 mm	20	112.89	119.51
3254			
20x9 mm	72	60.3	87.8
30x14 mm	36	100.6	129.6
3255			
18x6 mm	96	64.3	87.1
26x8.5 mm	48	87.6	125.6
3256			
14x8.5 mm	96	48.2	67.5
19x11.5 mm	96	104.5	140.1
27x16 mm	30	95.4	128.9
3257			
19x13 mm	96	58.3	76.3
27x19 mm	30	132.2	152.0
3258			
12x8.5 mm	96	37.09	58.18
16x11.5 mm	48	36.29	57.46
3261			
18 mm	72	78.34	110.31
28 mm	30	150.66	175.56
3265			
20x16 mm	72	113.5	138.4
26x21 mm	20	59.8	85.0
3267			
18x10 mm	96	96	133
3270			
16 mm	72	96.4	120.0
22 mm	24	72.3	117.4
3288			
8 mm	144	50.98	61.88
10 mm	72	53.86	80.27
12 mm	72	69.84	96.48
3293			
12 mm	72	72.3	95.7
20 mm	30	128.1	160.8
3400			
6 mm	360	47.5	58.4
8 mm	288	81.1	107.2
10 mm	144	72.3	93.4
3700			
6 mm	720	50.6	61.4
8 mm	288	62.2	88.4
10 mm	288	114.5	141.0
12 mm	144	105.4	128.5
14 mm	144	170.5	197.2
3708			
8x8.7 mm	144	17.781	36.530
12.5x13.6 mm	96	46.771	74.834

Self-adhesive Elements

Self-adhesive Elements such as Crystal-it, Crystal Fabric-it, Crystaltex-it Chaton or Crystal Rocks-it are eye-catching and innovative products that come ready-to-apply. They are pressure-sensitive and self-adhesive. When applied to paper and solid surfaces, they can create elegant, romantic or sporty designs.

Colors

-  **Crystal**
001
-  **Light Peach**
362
-  **Light Rose**
223
-  **Sun***
248
-  **Light Siam***
227
-  **Indian Siam**
327
-  **Fuchsia**
502
-  **Dark Siam**
308
-  **Amethyst**
204
-  **Aquamarine**
202
-  **Sapphire**
206
-  **Peridot**
214
-  **Emerald**
205
-  **Topaz**
203
-  **Jet**
280

Effects

-  **Crystal Silver Shade**
001 SSHA
-  **Crystal Aurore Boreale**
001 AB
-  **Crystal Golden Shadow**
001 GSHA
-  **Crystal Dorado**
001 DOR

Numerical Order

001	Crystal
001 AB	Crystal Aurore Boreale
001 DOR	Crystal Dorado
<u>001 GSHA</u>	<u>Crystal Golden Shadow</u>
<u>001 SSHA</u>	<u>Crystal Silver Shade</u>
202	Aquamarine
203	Topaz
204	Amethyst
205	Emerald
206	Sapphire
214	Peridot
223	Light Rose
227	Light Siam*
248	Sun*
280	Jet
308	Dark Siam
<u>327</u>	<u>Indian Siam</u>
362	Light Peach
502	Fuchsia

Alphabetical Order

Amethyst (204)
Aquamarine (202)
Crystal (001)
Crystal Aurore Boreale (001 AB)
Crystal Dorado (001 DOR)
<u>Crystal Golden Shadow (001 GSHA)</u>
<u>Crystal Silver Shade (001 SSHA)</u>
Dark Siam (308)
Emerald (205)
Fuchsia (502)
<u>Indian Siam (327)</u>
Jet (280)
Light Peach (362)
Light Rose (223)
Light Siam* (227)
Peridot (214)
Sapphire (206)
Sun* (248)
Topaz (203)

Classic Colors: This color range offers a wide choice of traditional Swarovski crystal colors.
Exclusive Colors: This color range is offered exclusively by Swarovski.

All colors and effects are available in SS 6 (S6T) and SS 10 (S10T).

* Not RoHS compliant, not suitable for packaging & paper

ARTICLE EXPLANATION

75 000



C	001/001
E	S6T/S10T
S	~62x21 (TAPE: 75x53)
M	16 PCS 70%

75 000	C	E	S	M	70%
Article number	Color assortment	Elements	Motif size in mm and size of the tape the motif is attached to in mm (TAPE)	Minimum order quantity in pieces (PCS)	Documentation size in %
	For details, please refer to the previous color chart at the beginning of this chapter. Color code 1 (001) corresponds to element 1 (S6T); color code 2 (001) corresponds to element 2 (S10T) etc.	Article 2012 in SS 6 (S6T) and SS 10 (S10T)			

11 Self-adhesive Elements

ORDERING EXAMPLE & PRODUCT VARIETY EXPLANATION

75 000	722	001	001
Article number	Carrier film color	Crystal color corresponding to element 1; color of most frequently used element in the motif	Crystal color corresponding to element 2; color of second most frequently used element in the motif
	722 White		
		Please see the respective color chart for all available code references.	



75 000



C	001/001
E	S6T/S10T
S	~62x21 (TAPE: 75x53)
M	16 PCS 70%

75 007

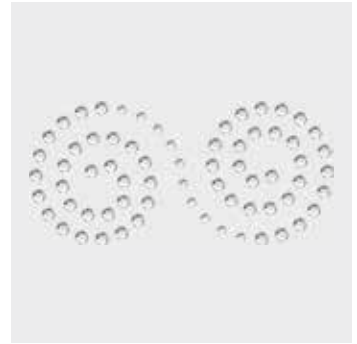

C	001/001/001
E	S6T/S10T/S10T
S	~62x29 (TAPE: 75x53)
M	16 PCS 65%

75 010

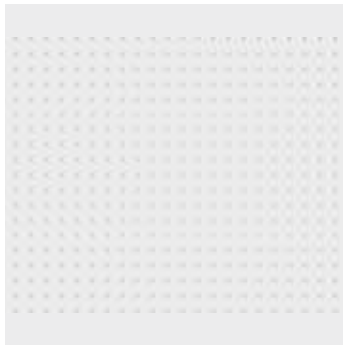

C	001
E	S6T
S	~272x182 (TAPE: 300x210)
M	1 PCS 20%

75 011



C	001
E	S10T
S	~273x183 (TAPE: 300x210)
M	1 PCS 20%

75 017



C	001AB
E	S6T
S	~60x85 (TAPE: 75x105)
M	8 PCS 45%

75 018



C	001
E	S6T
S	~47x86 (TAPE: 75x105)
M	8 PCS 45%

75 027



C	204/502/001AB
E	S6T/S6T/S6T
S	~51x32 (TAPE: 75x53)
M	16 PCS 80%

75 036

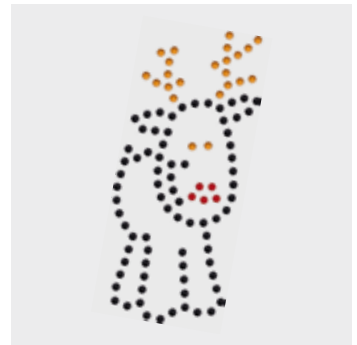

C	280/203/227
E	S6T/S6T/S6T
S	~31x72 (TAPE: 75x105)
M	8 PCS 55%

75 037



C	001/227/280
E	S6T/S6T/S10T
S	~49x74 (TAPE: 75x105)
M	8 PCS 55%

75 039



C	001AB/001
E	S6T/S10T
S	~35x31 (TAPE: 75x53)
M	16 PCS 100%

75 042



C	001DOR/205/227
E	S6T/S6T/S6T
S	~59x33 (TAPE: 75x53)
M	16 PCS 65%

75 047



C	001
E	S6T
S	~60x41 (TAPE: 75x53)
M	16 PCS
	70%

75 070



C	001/202/001AB
E	S6T/S6T/S10T
S	~46x50 (TAPE: 75x105)
M	8 PCS
	80%

75 071



C	001/001AB
E	S6T/S10T
S	~59x41 (TAPE: 75x53)
M	16 PCS
	70%

75 081



C	223
E	S6T
S	~41x34 (TAPE: 75x53)
M	16 PCS
	100%

ARTICLE EXPLANATION

70 809

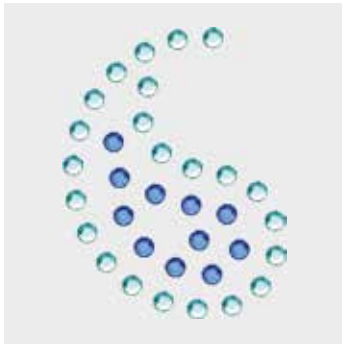

C	202/206
E	S10T/S10T
S	~30x38 (TAPE: 75x53)
M	16 PCS 100%

70 809	C	E	S	M	100%
Article number	Color assortment	Elements	Motif size in mm and size of the tape the motif is attached to in mm (TAPE)	Minimum order quantity in pieces (PCS)	Documentation size in %
	For details, please refer to the color chart at the beginning of this chapter. Color code 1 (202) corresponds to element 1 (S10T); color code 2 (206) corresponds to element 2 (S10T) etc.	Article 2012 in SS 6 (S6T) and SS 10 (S10T)			

ORDERING EXAMPLE & PRODUCT VARIETY EXPLANATION

70 809	012	202	206
Article number	Carrier film color	Crystal color corresponding to element 1; color of most frequently used element in the motif	Crystal color corresponding to element 2; color of second most frequently used element in the motif
	012 Black 022 White	Please see the respective color chart for all available code references.	



70 008



C	001
E	S10T
S	~39x19 (TAPE: 75x53)
M	16 PCS
	100%

70 010

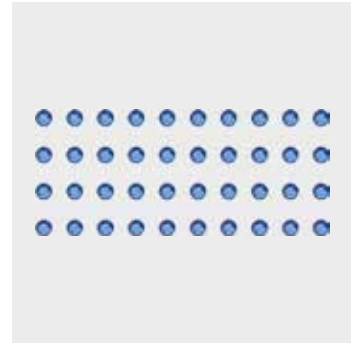

C	206
E	S10T
S	~49x21 (TAPE: 75x53)
M	16 PCS
	80%

70 011



C	203
E	S10T
S	~37x29 (TAPE: 75x53)
M	16 PCS
	100%

70 070

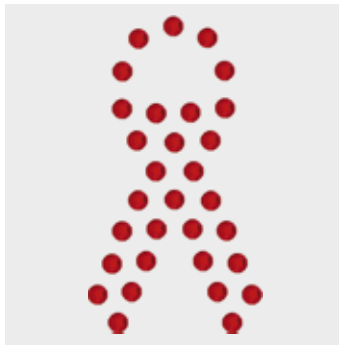

C	227
E	S10T
S	~42x23 (TAPE: 75x53)
M	16 PCS
	100%

70 214



C	001
E	S10T
S	~30x28 (TAPE: 75x53)
M	16 PCS
	100%

70 303



C	202
E	S10T
S	~53x42 (TAPE: 75x53)
M	16 PCS
	80%

70 310

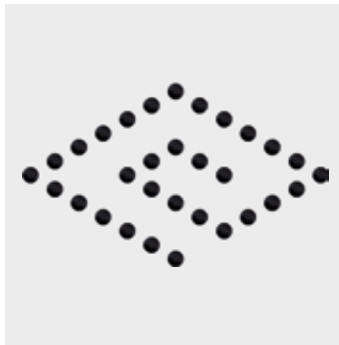

C	280
E	S10T
S	~51x30 (TAPE: 75x53)
M	16 PCS
	80%

70 314

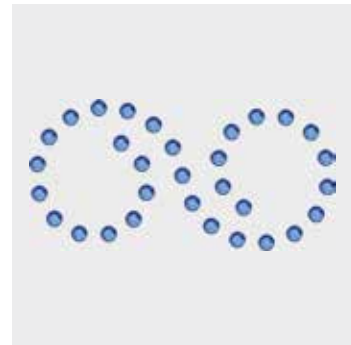

C	206
E	S10T
S	~51x25 (TAPE: 75x53)
M	16 PCS
	80%

70 802

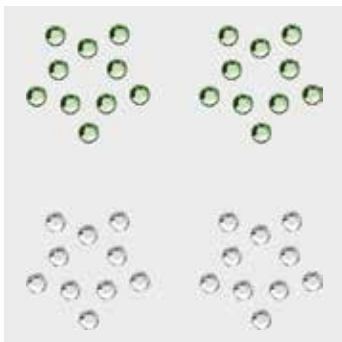

C	214/001
E	S10T/S10T
S	~39x40 (TAPE: 75x53)
M	16 PCS
	100%

70 803

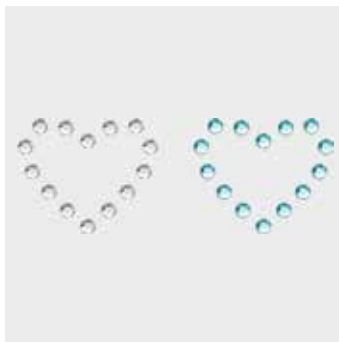

C	202/001
E	S10T/S10T
S	~56x20 (TAPE: 75x53)
M	16 PCS
	75%

70 807



C	203/280/001
E	S10T/S10T/S10T
S	~55x35 (TAPE: 75x53)
M	16 PCS
	75%

70 809



C	202/206
E	S10T/S10T
S	~30x38 (TAPE: 75x53)
M	16 PCS
	100%

70 813



C	001/205/214
E	S10T/S10T/S10T
S	~39x34 (TAPE: 75x53)
M	16 PCS
	100%

70 815

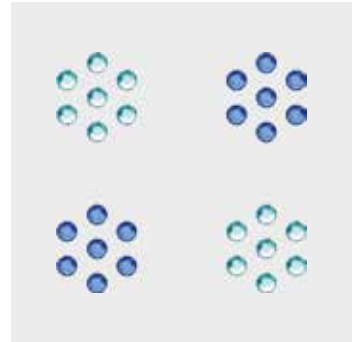

C	202/206
E	S10T/S10T
S	~33x32 (TAPE: 75x53)
M	16 PCS
	100%

71 000

01

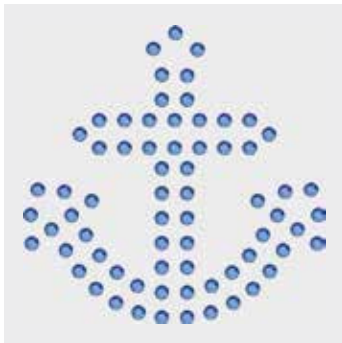

C	206
E	S6T
S	~40x39 (TAPE: 75x53)
M	16 PCS
	100%

71 001



C	001AB/205/202
E	S6T/S6T/S6T
S	~42x36 (TAPE: 75x53)
M	16 PCS
	100%

71 003

01



C	001
E	S6T
S	~37x38 (TAPE: 75x53)
M	16 PCS
	100%

71 009

01



C	204/223
E	S6T/S6T
S	~22x22 (TAPE: 38x53)
M	32 PCS
	100%

71 014

01



C	001DOR/280
E	S6T/S6T
S	~63x42 (TAPE: 75x53)
M	16 PCS
	60%

71 015

01

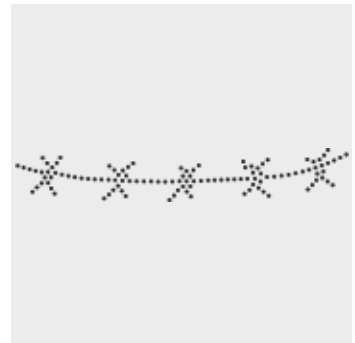

C	280
E	S6T
S	~26x163 (TAPE: 43x210)
M	7 PCS
	27%

71 016

01



C	001AB
E	S6T
S	~21x92 (TAPE: 75x105)
M	8 PCS
	45%

71 020



C	001
E	S6T
S	~18x30 (TAPE: 38x53)
M	32 PCS
	100%

71 028

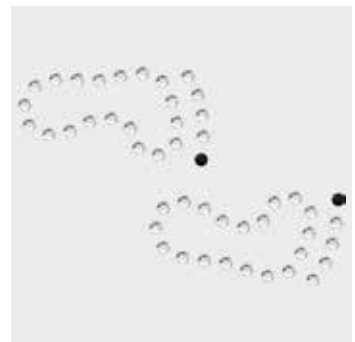

C	001/280
E	S6T/S6T
S	~48x32 (TAPE: 75x53)
M	16 PCS
	90%

71 046



C	206/202
E	S6T/S6T
S	~48x35 (TAPE: 75x53)
M	16 PCS 85%

71 401

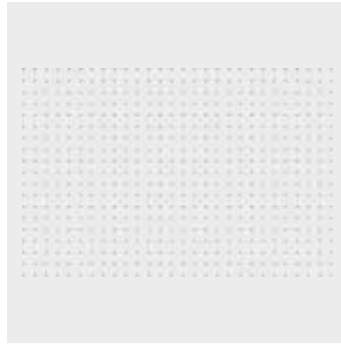

C	001
E	S10T
S	~273x183 (TAPE: 300x210)
M	1 PCS 15%

ARTICLE EXPLANATION

Crystal Fabric-it consists of Crystal Fabric with a self-adhesive film.

57 000



C	001 AB
W	001, 002, 003, 005, 010, 015
M	10 M* 100%

57 000	C	W	M	100%
Article number	Color of crystals	Width of the banding	Minimum order quantity in meters (M)	Documentation size in %

ORDERING EXAMPLE & PRODUCT VARIETY EXPLANATION

57 000	002		010	001 AB	
Article number	3-digit code for width		Color of film	Color of crystals	
	001	1 cm	1 010 Transparent	001 AB	Crystal Aurore Boreale
	002	2 cm	1 012 Black	001 CAL	Crystal Comet Argent Light
	003	3 cm		001 COP	Crystal Copper
	005	5 cm		001 DOR	Crystal Dorado
	010	10 cm		001 GSHA	Crystal Golden Shadow
	015	15 cm		001 MLGLD	Crystal Metallic Light Gold
				001 MOL	Crystal Moonlight
				280 HEM	Jet Hematite

* Please note: Bandings can be divided.

OVERVIEW OF AVAILABLE COLORS & EFFECTS

57 000



C	001 AB
W	001, 002, 003, 005, 010, 015
M	10 M* 100%

57 000



C	001 CAL
W	001, 002, 003, 005, 010, 015
M	10 M* 100%

57 000



C	001 COP
W	001, 002, 003, 005, 010, 015
M	10 M* 100%

57 000



C	001 DOR
W	001, 002, 003, 005, 010, 015
M	10 M* 100%

57 000



C	001 GSHA
W	001, 002, 003, 005, 010, 015
M	10 M* 100%

57 000



C	001 MLGLD
W	001, 002, 003, 005, 010, 015
M	10 M* 100%

57 000











C	001 MOL
W	001, 002, 003, 005, 010, 015
M	10 M* 100%

57 000



C	280 HEM
W	001, 002, 003, 005, 010, 015
M	10 M* 100%

57 000		Width in cm						Color of Film	
		001	002	003	005	010	015	I010 Transparent	I012 Black
Crystal Effects									
Transparent Effects									
 Crystal Aurore Boreale (001 AB)		■	■	■	■	■	■	■	■
 Crystal Copper (001 COP)		■	■	■	■	■	■	■	■
 Crystal Golden Shadow (001 GSHA)		■	■	■	■	■	■	■	■
 Crystal Moonlight (001 MOL)		■	■	■	■	■	■	■	■
Metallic Effects									
 Crystal Comet Argent Light (001 CAL)		■	■	■	■	■	■	■	■
 Crystal Dorado (001 DOR)		■	■	■	■	■	■	■	■
 Crystal Metallic Light Gold (001 MLGLD)		■	■	■	■	■	■	■	■
Color Effects									
Metallic Effects									
 Jet Hematite (280 HEM)		■	■	■	■	■	■	■	■

ARTICLE EXPLANATION

57 353



C	012-280HEM
S	~36x31
M	126 PCS
	100%

57 353	S	M	100%
Article number	Motif size in mm	Minimum order quantity in pieces (PCS)	Documentation size in %

ORDERING EXAMPLE & PRODUCT VARIETY EXPLANATION

57 353	012	280 HEM
Article number	Type and color of base material	Color of crystals
	I It version	001 AB Crystal Aurore Boreale
	010 Transparent	001 CAL Crystal Comet Argent Light
	012 Black	001 COP Crystal Copper
		001 DOR Crystal Dorado
		001 GSHA Crystal Golden Shadow
		001 MLGLD Crystal Metallic Light Gold
		001 MOL Crystal Moonlight
		280 HEM Jet Hematite

All Crystal Fabric-it Motifs are available in certain color/film variations (see colormatrix p. 366). Generally all current Crystal Fabric Motifs are available as Crystal Fabric-it version as soon as they respect the maximum possible size. Furthermore, it may occur that slight adjustments are needed to fulfill the design requirements of Crystal Fabric-it.



57 351



C	010-001AB	
S	~34x30	
M	140 PCS	100%

57 352



C	010-001AB	
S	~42x41	
M	90 PCS	90%

57 353



C	012-280HEM	
S	~36x31	
M	126 PCS	100%

ARTICLE EXPLANATION

Crystaltext-it Bandings are available with transparent and black base material and have a self-adhesive film for the application.

62 000

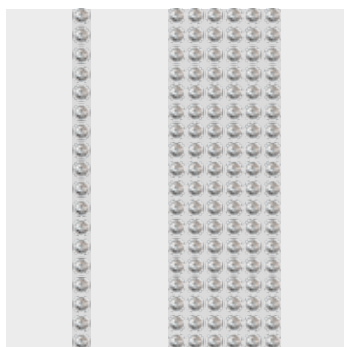





















R	001-012; 57
SS	SS 6 (2038)
M	10 M* 100%

62 000	R	SS	M	100%
Article number	This article is available in 1-12 and 57 rows.	Stone size	Minimum Order Quantity in meters (M)	Documentation size in %

ORDERING EXAMPLE & PRODUCT VARIETY EXPLANATION

62 000	006	I010	001
Article number	3-digit code for number of rows	Type and color of base material I It version 010 Transparent 012 Black	Color of crystals Please see the respective product matrix for all available code references.

* Please note: Bandings can be divided.

62 000* 62 010** 62 011***		Stone Size	SS 6	SS 10	Base Material	I010 Transparent	I012 Black
Crystal							
 Crystal F (001)			■	■		■	■
Colors							
Plain Colors							
 Amethyst F (204)			■	■		■	■
 Aquamarine F (202)			■	■		■	■
 Black Diamond F (215)			■	■		■	■
 Fuchsia F (502)			■	■		■	■
 Jet F (280)			■	■		■	■
 Light Rose F (223)			■	■		■	■
 Light Siam F (227)			■	■		■	■
 Peridot F (214)			■	■		■	■
 Sapphire F (206)			■	■		■	■
 Silk F (391)			■	■		■	■
 Smoked Topaz F (220)			■	■		■	■
Crystal Effects							
Transparent Effects							
 Crystal AB F (001 AB)			■	■		■	■
 Crystal Golden Shadow F (001 GSHA)			■	■		■	■
 Crystal Luminous Green F (001 LUMG)			■	■		■	■
 Crystal Silver Shade F (001 SSHA)			■	■		■	■
Metallic Effects							
 Crystal Dorado F (001 DOR)			■	■		■	■
 Crystal Iridescent Green F (001 IRIG)			■	■		■	■
 Crystal Rose Gold F (001 ROGL)			■	■		■	■
Color Effects							
Metallic Effects							
 Jet Hematite F (280 HEM)			■	■		■	■

* Not available in 13–56 rows (62 000).

** Not available in 13–21 and 23–43 rows (62 010).

*** Not available in 8–44 rows (62 011).

ARTICLE EXPLANATION

Crystaltex-it Bandings Motifs are available with transparent and black base material and have a self-adhesive film for the application. All Standard Crystaltex-it Banding Motifs are also available as a Hotfix version.

66 021

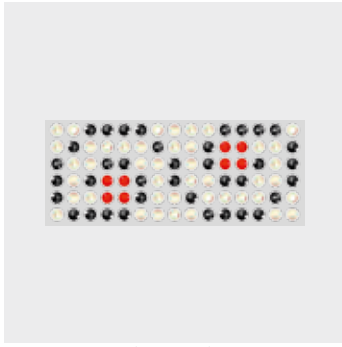

C	I010-001AB/280HEM/227
E	S6/S6/S6
S	~39x16
M	18.749 M (480 PCS) 85%

66 021	C	E	S	M	100%
Article number	Color assortment	Elements	Motif size in mm	Minimum Order Quantity in meters (M); pieces (PCS)	Documentation size in %
	Color of base material (I010) is separated from crystal colors with a hyphen. Color code 1 (001 AB) corresponds with element 1; color code 2 (280 HEM) corresponds with element 2 etc.	Crystaltex-it Bandings Motifs are available in stone sizes SS 6 and SS 10 in close stone setting.			

ORDERING EXAMPLE & PRODUCT VARIETY EXPLANATION

66 021	I010	001 AB	280 HEM	227
Article number	Type and color of base material	Crystal color corresponding to element 1; color of most frequently used element in the motif	Crystal color corresponding to element 2; color of second most frequently used element in the motif	Crystal color corresponding to element 3; color of third most frequently used element in the motif
	It version 010 Transparent 012 Black	Please see the respective product matrix for all available code references.		



66 001

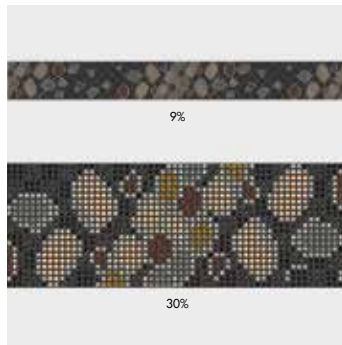

C	I012-280HEM/280/001SSHA/ 001GSHA/220/215/001DOR
E	S6/S6/S6/S6/S6/S6
S	~250X55
M	5 M (20 PCS)

66 021

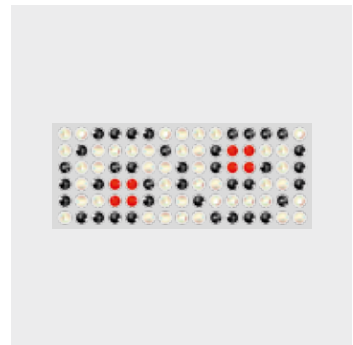

C	I010-001AB/280HEM/227
E	S6/S6/S6
S	~39x16
M	18.749 M (480 PCS) 85%

66 036

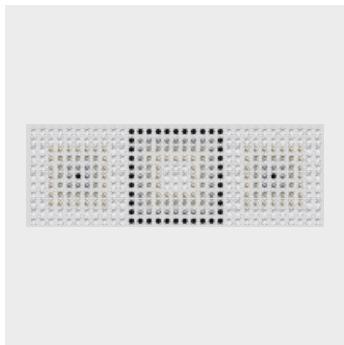

C	I010-001/001SSHA/215/280HEM/280
E	S6/S6/S6/S6/S6
S	~86x29
M	4.297 M (50 PCS) 45%

PRODUCT DETAILS

Article Number	Standard Motifs (as shown)				Modified Standard Motifs (change of color)			
	Packing Unit = MOQ		MOQ for Samples		MOQ		MOQ for Samples	
	in meters	in pieces	in meters	in pieces	in meters	in pieces	in meters	in pieces
66 001	4.297	50	0.086	1	8.593	100	0.687	8
66 021	4.687	120	0.039	1	18.749	480	1.875	48
66 036	4.297	50	0.086	1	8.593	100	0.687	8

The MOQ for Standard Motifs is 1 packing unit (approx. 5 meters). Samples can be ordered below 1 packing unit. If the Standard Motifs are modified (color changes), please refer to the detailed MOQ information in the table above. This product must be ordered in meters.

ARTICLE EXPLANATION

Crystaltext-it Motifs are available with transparent and black base material and have a self-adhesive film for the application. All Standard Crystaltext-it Motifs are also available as a Hotfix version.

65 281

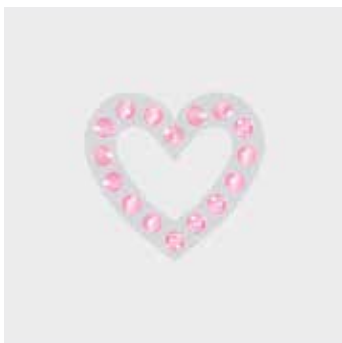

C	I010-223
E	S10
S	~24x22
M	105 PCS 100%

65 281	C	E	S	M	100%
Article number	Color assortment	Elements	Motif size in mm	Minimum order quantity in pieces (PCS)	Documentation size in %
	Color of base material (I010) is separated from crystal colors with a hyphen. Color code 1 (223) corresponds with element 1.	Crystaltext-it Motifs are available in stone sizes SS 6 and SS 10.			

11 Self-adhesive Elements

ORDERING EXAMPLE & PRODUCT VARIETY EXPLANATION

65 281	I010	223
Article number	Type and color of base material	Crystal color corresponding to element 1; color of most frequently used element in the motif
	I It version	
	010 Transparent 012 Black	Please see the respective product matrix for all available code references.

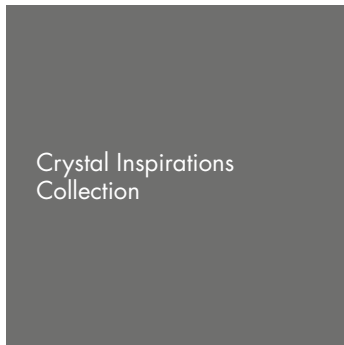

65 281 F/W 2010/11

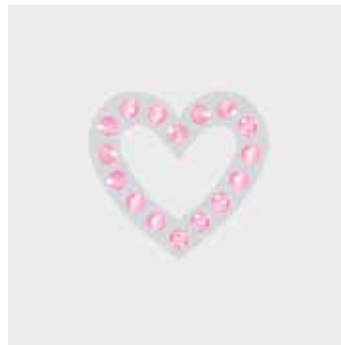

C	I010-223	
E	S10	
S	~24x22	
M	105 PCS	100%

ARTICLE EXPLANATION

62 030

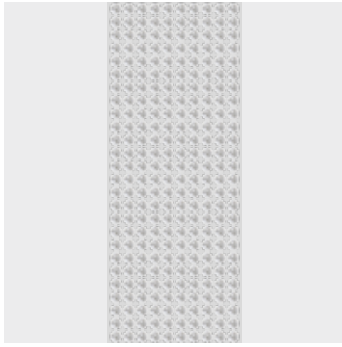

R	002-010, 088
SS	PP 9 (1028)
M	5 M* 100%

62 031 (Honeycomb)

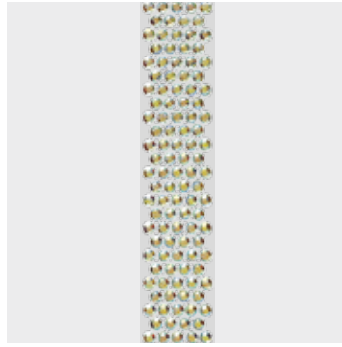

R	003-006, 10, 17
SS	PP 9 (1028)
M	5 M* 100%

62 030	R	SS	M	100 %
Article number	This article is available in 2-10 and 88 rows.	Stone size	Minimum order quantity in metre (M)	Documentation size in %
62 031	R	SS	M	100 %
Article number	This article is available in 3-6, 10 and 17 rows.	Stone size	Minimum order quantity in metre (M)	Documentation size in %

ORDERING EXAMPLE & PRODUCT VARIETY EXPLANATION

62 030	010	I010	001
Article number	3-digit code for number of rows	Type and color of base material I It Version 010Transparent 012 Black	Color of crystals Please see the respective product matrix for all available code references.
62 031	003	I010	001
Article number	3-digit code for number of rows	Type and color of base material I It Version 010Transparent 012Black	Color of crystals Please see the respective product matrix for all available code references.

* Please note: Bandings can be divided.

62 030

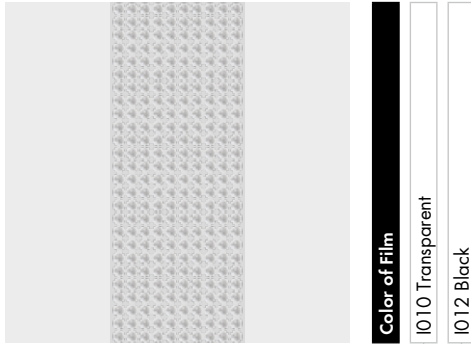

Crystal		I010 Transparent	I012 Black
Crystal F (001)			
Colors			
Plain Colors			
Aquamarine F (202)			
Black Diamond F (215)			
Dark Indigo F (288)			
Fuchsia F (502)			
Indicolite F (379)			
Jet F (280)			
Khaki F (550)			
Light Siam F (227)			
Rose F (209)			
Smoked Topaz F (220)			
Tanzanite F (539)			
Crystal Effects			
Transparent Effects			
Crystal Aurore Boreale F (001 AB)			
Crystal Golden Shadow F (001 GSHA)			
Crystal Silver Shade F (001 SSHA)			
Metallic Effects			
Crystal Dorado (001 DOR)			
Crystal Iridescent Green F (001 IRIG)			
Color Effects			
Metallic Effects			
Jet Hematite (280 HEM)			

62 031 (Honeycomb)

	Rows	3 rows	4 rows	5 rows	6 rows	10 rows	17 rows	Color of Film	I010 Transparent	I012 Black
Crystal										
Crystal F (001)		■	■	■	■	■	■		■	■
Colors										
Plain Colors										
Aquamarine F (202)		■	■	■	■	■	■		■	■
Black Diamond F (215)		■	■	■	■	■	■		■	■
Dark Indigo F (288)		■	■	■	■	■	■		■	■
Jet F (280)		■	■	■	■	■	■		■	■
Crystal Effects										
Transparent Effects										
Crystal Aurore Boreale F (001 AB)		■	■	■	■	■	■		■	■
Crystal Golden Shadow F (001 GSHA)		■	■	■	■	■	■		■	■
Crystal Silver Shade F (001 SSHA)		■	■	■	■	■	■		■	■
Metallic Effects										
Crystal Dorado (001 DOR)		■	■	■	■	■	■		■	■
Crystal Iridescent Green F (001 IRIG)		■	■	■	■	■	■		■	■
Color Effects										
Metallic Effects										
Jet Hematite (280 HEM)		■	■	■	■	■	■		■	■

ARTICLE EXPLANATION

Crystaltex-it Chaton Motifs are available with a transparent and black base material and have a self-adhesive film for application. All Standard Crystaltex-it Chaton Motifs are also available as a Hotfix version.

85 132



C	I010-202/001AB/379
E	PP9/PP9/PP9
S	~35x35
M	36 PCS 100%

85 132	C	E	S	M	100%
Article number	Color assortment	Elements	Motif size in mm	Minimum order quantity in pieces (PCS)	Documentation size in %
	Color of base material (I010) is separated from crystal colors with a hyphen. Color code 1 (202) corresponds with element 1; color code 2 (001 AB) corresponds with element 2 etc.	Crystaltex-it Chaton Motifs are available in stone size PP 9.			

ORDERING EXAMPLE & PRODUCT VARIETY EXPLANATION

85 132	I010	202	001 AB	379
Article number	Type and color of base material	Crystal color corresponding to element 1; color of most frequently used element in the motif	Crystal color corresponding to element 2; color of second most frequently used element in the motif	Crystal color corresponding to element 3; color of third most frequently used element in the motif
	I It version 010 Transparent 012 Black	Please see the respective product matrix for all available code references.		

Self-adhesive Elements

Crystaltex-it Chaton Motifs

Standard Collection



Standard Collection

85 102



C	I010-001	
E	PP9	
S	~23x14	
M	135 PCS	100%

85 107

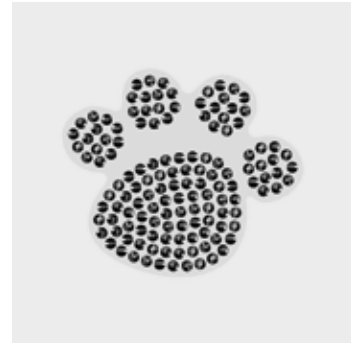

C	I010-280HEM	
E	PP9	
S	~32x28	
M	60 PCS	100%

85 123

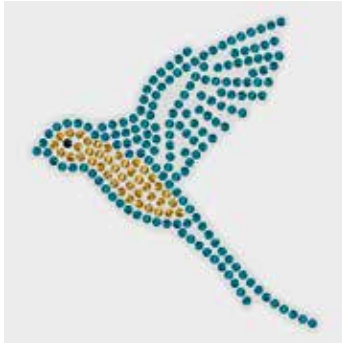

C	I010-379/001DOR/280	
E	PP9/PP9/PP9	
S	~49x53	
M	30 PCS	80%

85 125



C	I010-280	
E	PP9	
S	~26x30	
M	60 PCS	100%

85 132

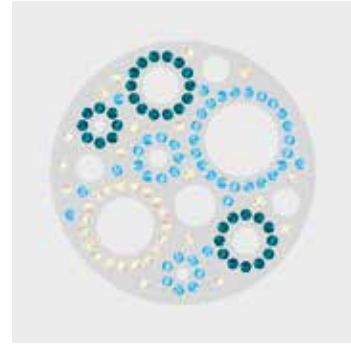

C	I010-202/001AB/379	
E	PP9/PP9/PP9	
S	~35x35	
M	36 PCS	100%

CRYSTAL ROCKS-IT & CRYSTAL FINE ROCKS-IT

With Crystal Rocks-it (72 003) and Crystal Fine Rocks-it (74 000) two absolutely popular products are available with the easy-to-use "-it" self-adhesive technique.

72 003

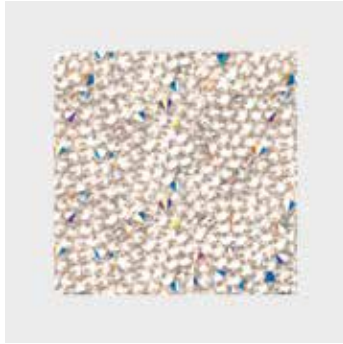

C	I010-001AB
S	~40x40
M	48 PCS
	80%

74 000



C	I012-280
S	~97x100
M	9 PCS
	40%

ORDERING EXAMPLE & PRODUCT VARIETY EXPLANATION

72 003	I010	001 SSHA
Article number	Color of film	Color of crystals
	I010 Transparent	001 AB Crystal Aurore Boreale
	I012 Black	001 BBL Crystal Bermuda Blue
		001 CAL Crystal Comet Argent Light
		001 GSHA Crystal Golden Shadow
		001 MLGLD Crystal Metallic Light Gold
		001 METSI Crystal Metallic Silver
		001 REDM Crystal Red Magma
		001 SSHA Crystal Silver Shade
		280 Jet

OVERVIEW OF AVAILABLE COLORS & EFFECTS*

Jet (280)



012 Black

Crystal Aurore Boreale (001 AB)

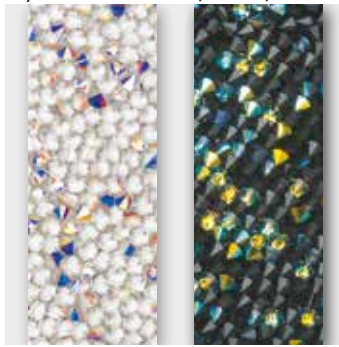

010 Transparent

012 Black

Crystal Bermuda Blue (001 BBL)



012 Black

Crystal Golden Shadow (001 GSHA)



010 Transparent

Crystal Red Magma (001 REDM)



010 Transparent

012 Black

Crystal Silver Shade (001 SSHA)



010 Transparent

012 Black

Crystal Comet Argent Light (001 CAL)

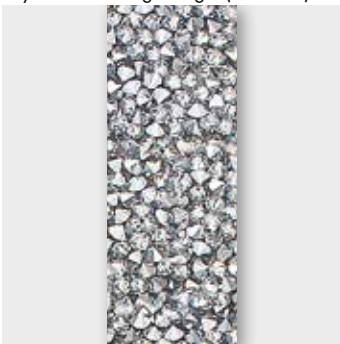

010 Transparent

Crystal Metallic Light Gold (001 MLGLD)



010 Transparent

Crystal Metallic Silver (001 METSI)



010 Transparent

012 Black

* Please note that all effects are also available for Crystal Fine Rocks-it.

72 000 – 72 999 (Crystal Rocks-it)		74 000 – 74 999 (Crystal Fine Rocks-it)	
Color of Film		I010 Transparent	I012 Black
Colors			
Plain Colors			
● Jet (280)			■
Crystal Effects			
Transparent Effects			
● Crystal Aurore Boreale (001 AB)		■	■
● Crystal Bermuda Blue (001 BBL)			■
● Crystal Golden Shadow (001 GSHA)		■	
● Crystal Red Magma (001 REDM)		■	■
● Crystal Silver Shade (001 SSHA)		■	■
Metallic Effects			
● Crystal Comet Argent Light (001 CAL)		■	
● Crystal Metallic Light Gold (001 MLGLD)		■	
● Crystal Metallic Silver (001 METSI)		■	■

A special motif is any individual design created by the customer, which is different from the Self-adhesive Elements Standard or Crystal Inspirations Collections. This service opens up many customization possibilities and enables you to profit from Swarovski's longtime experience and design expertise. A range of customization options for existing Motifs is available (see "Customization Possibilities" below). You may also submit sketches of a design that will suit your special needs – such as a brand image or an image to suit a particular sales campaign. This will then be made up according to your specifications using Computer Aided Design which allows for easy adjustments according to your needs.

CUSTOMIZATION POSSIBILITIES FOR CRYSTAL-IT & CRYSTAL TATTOO

- Change of elements of an existing motif
- Change of size of an existing motif
- Logos or brand names
- Up to three colors with two elements (S6T, S10T) possible per Crystal-it / Crystal Tattoo motif

CUSTOMIZATION POSSIBILITIES FOR CRYSTAL FABRIC-IT MOTIFS

- Maximum motif size: 620x1800 mm
- Minimum motif size: 10x10 mm
- Minimum width of holes within motifs: 3 mm
- Minimum Crystal Fabric-it surface: 3 mm
- Minimum size of the smallest element within a motif: 10x10 mm

It is generally possible to draw motifs with a minimum gap of 3 mm between the outlines. However, due to the tolerance level of the crystals being applied onto carrier film, the final Crystal Fabric-it Motifs may generally differ from the sketches or prints in relation to the motifs' outline, especially with regards to spaces that are smaller than 4 mm. Therefore the motif, and by extension the product itself, may be subject to individual variations with each reproduction. These variations are caused by technical production related factors. As these variations are not deemed to be defects, warranty claims shall therefore not be entertained by Swarovski.

Special productions are generally offered to all our customers if feasibility is given and our General Terms and Conditions are applied. Please note that the simple order of a design does not grant exclusive production of this design to the customer.

If detailed information on the possible tolerances is needed (e.g. cavity production for a metal part), please contact Swarovski who will place an application request within our application database.

CUSTOMIZATION POSSIBILITIES FOR CRYSTALTEX-IT BANDINGS MOTIFS

Motifs come in rows and per meter

Pattern repeats:

- Min. size 1x2 rows
- Max. size 50 cm x maximum rows (44 or 57)
- Up to eight colors are possible for Crystaltex-it Bandings Motifs using either SS 6 or SS 10 stones (mix of stone sizes is not possible).

Special productions are generally offered to all our customers if feasibility is given and our General Terms and Conditions are applied.

Please note that the simple order of a design does not grant exclusive production of this design to the customer.

Bandings may be delivered cut up to 3 pieces per packaging.

In case the size of the motif is smaller than 50 cm, the packing unit might be under 5 meters.

CUSTOMIZATION POSSIBILITIES FOR CRYSTALTEX-IT MOTIFS

Min. size: 12x12 mm (4x4 stones)

Max. size: 122x162 mm

Distance between the Flat Backs SS 10 (from stone centre to stone centre):

- Max. 4.8 mm
- Min. 3.4 mm

Distance between the Flat Backs SS 6 (from stone centre to stone centre):

- Max. 3.7 mm
- Min. 2.4 mm

Up to eight colors are possible for Crystaltext-it Motifs using either SS 6 or SS 10 stones (mix of stone sizes is not possible).

Special productions are generally offered to all our customers if feasibility is given and our General Terms and Conditions are applied.

Please note that the simple order of a design does not grant exclusive production of this design to the customer.

CUSTOMIZATION POSSIBILITIES FOR CRYSTALTEX-IT CHATON MOTIFS

▪ Min. size: 10x10 mm

▪ Max. size: 122x157 mm

Distance between Chatons 1028 PP 9 (from stone center to stone center): min. 1.70 mm – max. 4.5 mm

Up to four colors are possible for Crystaltext and Crystaltext-it Chaton Motifs using stone size PP 9.

CUSTOMIZATION POSSIBILITIES FOR CRYSTAL ROCKS-IT

▪ Min. size: 15x15 mm or effective surface of 2.25 cm²

▪ Max. size: 400x330 mm

▪ Min. Crystal Rocks surface: 9 mm

▪ Min. width of holes within motifs: 3 mm

▪ Min. size of the smallest element within a motif: 15x15 mm or effective surface of 2.25 cm²

Due to production issues, motifs with edges and angles of less than 90° need to be rounded off. Tolerance value = 3 mm.

If detailed information on the possible tolerances is needed (e.g. cavity production for a metal part), please contact Swarovski who will place an application request within our application database.

CUSTOMIZATION POSSIBILITIES FOR CRYSTAL FINE ROCKS-IT

▪ Min. size: 15x15 mm

▪ Max. size: 400x330 mm

▪ Min. Crystal Fine Rocks surface: 4 mm

▪ Min. width of holes within motifs: 3 mm

▪ Min. size of the smallest element within a motif: 15x15 mm

If detailed information on the possible tolerances is needed (e.g. cavity production for a metal part), please contact Swarovski who will place an application request within our application database.

ORDERING PROCESS

Send the request with a drawing you wish to order to your nearest Swarovski sales office. Make sure you include all measurements to the desired motif. Please also indicate, which product group your special motif refers to (Crystal-it, Crystal Tattoos, Crystal Fabric-it, Crystaltex-it, Crystaltex-it Chaton, Crystal Rocks-it, Crystal Fine Rocks-it). You will then receive a quotation including your article number, minimum order quantity, price and the line drawing of your special motif in PDF format. Please contact your Swarovski sales office again if any changes need to be made. Your special motif will be produced and delivered following your confirmation.

PLEASE NOTE

Please always submit your drawing of the desired motif to represent it in the actual size you require. A small sketch, when enlarged to the desired size, will have blurred lines that will make it difficult to correctly reinterpret. Pictures or drawings representing 100% size of the design or very good quality scans in JPG, BMP or DXF format will ensure that we have clear data to work with. These can also be sent via e-mail or on a CD-ROM. If sending a sewing pattern, please include the whole pattern and not just cut outs. When the sketch is submitted as a hard copy by fax or e-mail, please include a scale legend (e.g. copy/scan with ruler next to the drawing). This will ensure that the desired size of the motif can be identified.

Special productions are generally offered to all our customers if feasibility is given and our General Terms and Conditions are applied. Please note that the simple order of a design does not grant exclusive production of this design to the customer.

If detailed information on the possible tolerances is needed (e.g. cavity production for a metal part), please contact Swarovski who will place an application request within our application database.

**WARNING FOR CRYSTAL TATTOOS**

Crystal Tattoos may be applied on healthy skin only. Do not adhere to eyes or on mucous membranes. Crystal Tattoos are not recommended for young children. Loose crystals may present a small parts hazard to young children, particularly children under three years old. If a crystal comes loose, depending on the size of the crystal, children may choke on, inhale, swallow or insert the crystal into the nose.

Transfers

Transfers are ideal for Hotfix application on all kinds of textiles. They are available in a large range of motifs and numbers of rows, which are made up of different articles from the Flat Back Hotfix assortment. Featuring designs from the in-house design team, they can comprise XIRIUS and XILION Roses, or Creation Stones, as well as Metallics and Cabochons. The Transfer Motifs offered are divided in three categories: Standard Collection, Crystal Inspirations Collections, and Special Collections in order to suit all needs in the targeted segments such as womenswear, sports and casual wear, childrenwear etc.

STANDARD COLLECTION

CRYSTAL INSPIRATIONS COLLECTIONS

SPECIAL COLLECTIONS

CHATON LEATHER

COLORS & EFFECTS

Colors



Crystal
001



White Opal
234



Light Silk
261



Silk
391



Light Peach
362



Rosaline
508



Vintage Rose
319



Light Rose
223



Rose Peach
262



Padparadscha
542



Indian Pink
289



Sun
248



Fireopal
237



Hyacinth
236



Light Siam
227



Indian Siam*
327



Rose
209



Fuchsia
502



Ruby
501



Siam
208



Burgundy
515



Amethyst
204



Purple Velvet
277



Cobalt
369



Tanzanite
539



Light Amethyst
212



Provence Lavender
283



Light Sapphire
211



Aquamarine
202



Sapphire
206



Capri Blue
243



Dark Indigo
288



Montana
207



Caribbean Blue Opal
394



Light Turquoise
263



Blue Zircon
229



Denim Blue
266



Black Diamond
215



Pacific Opal
390



Chrysolite Opal
294



Chrysolite
238



Peridot
214



Erinite
360



Fern Green
291



Dark Moss Green
260



Emerald
205



Olivine
228



Khaki
550



Greige
284



Light Grey Opal
383



Light Colorado Topaz
246



Jonquil
213



Citrine
249



Light Topaz
226



Sunflower
292



Topaz
203



Tangerine
259



Smoked Topaz
220



Mocca
286



Jet
280

Ceramics



Marbled Light Grey
657



Marbled Terracotta
655



Marbled Yellow
652



Marbled Blue
654



Marbled Black
653

Effects



Crystal Halfix Transparent*
001 HFT



Crystal Silver Shade
001 SSHA



Crystal Moonlight
001 MOL



Crystal Aurore Boreale
001 AB



Crystal Luminous Green***
001 LUMG



Crystal Golden Shadow
001 GSHA



Crystal Rose Gold
001 ROGL



Crystal Copper
001 COP



Crystal Astral Pink
001 API



Light Siam Aurore Boreale
227 AB



Light Siam Satin
227 SAT



Crystal Red Magma
001 REDM



Light Rose Aurore Boreale
223 AB



Crystal Antique Pink***
001 ANTP



Crystal Transmission
Halfix Transparent
001 TRA HFT



Crystal Volcano
001 VOL



Crystal Lilac Shadow
001 LISH



Sapphire Satin
206 SAT



Crystal Metallic Blue
001 METBL



Crystal Meridian Blue
001 MBL



Crystal Blue Shade
001 BLSH



Blue Zircon Satin
229 SAT



Jonquil Aurore Boreale
213 AB



Jonquil Satin
213 SAT



Crystal Tabac
001 TAB



Crystal Iridescent Green
001 IRIG



Crystal Dorado
001 DOR



Crystal Metallic Light Gold
001 MLGLD



Crystal Bronze Shade***
001 BRSH



Smoked Topaz Satin
220 SAT



Topaz Aurore Boreale
203 AB



Crystal Silver Night
001 SINI



Jet Nut
280 NUT



Crystal Cosmojet*
001 COS



Jet Hematite
280 HEM



Jet Aurore Boreale
280 AB

XILION Rose 2038

 SS 5
(S5)

 SS 6
(S6)

 SS 8
(S8)

 SS 10
(S10)

XIRIUS Rose 2078

 SS 12
(S12)

 SS 20
(S20)

 SS 34
(S34)

 SS 48
(S48)

 SS 16
(S16)

 SS 30
(S30)

 SS 40
(S40)

Numerical Order

001 Crystal	202 Aquamarine	229 Blue Zircon	291 <u>Fern Green</u>
001 AB Crystal Aurore Boreale	203 Topaz	229 SAT Blue Zircon Satin	292 <u>Sunflower</u>
001 ANTP Crystal Antique Pink***	203 AB Topaz Aurore Boreale	234 White Opal	294 <u>Chrysolite Opal</u>
001 API Crystal Astral Pink	204 Amethyst	236 Hyacinth	319 <u>Vintage Rose</u>
001 BLSH Crystal Blue Shade	205 Emerald	237 Fireopal*	327 <u>Indian Siam*</u>
001 BRSH Crystal Bronze Shade***	206 Sapphire	238 Chrysolite	360 <u>Erinite</u>
001 COP Crystal Copper	206 SAT Sapphire Satin	243 Capri Blue	362 <u>Light Peach</u>
001 COS Crystal Cosmojet*	207 Montana	246 Light Colorado Topaz	369 <u>Cobalt</u>
001 DOR Crystal Dorado	208 Siam	248 Sun	383 <u>Light Grey Opal</u>
001 GSHA Crystal Golden Shadow	209 Rose	249 Citrine	390 <u>Pacific Opal</u>
001 HFT Crystal Hoftix Transparent*	211 Light Sapphire	259 Tangerine	391 <u>Silk</u>
001 IRIG Crystal Iridescent Green	212 Light Amethyst	260 Dark Moss Green	394 <u>Caribbean Blue Opal</u>
001 LISH Crystal Lilac Shadow	213 Jonquil	261 Light Silk	501 <u>Ruby</u>
001 LUMG Crystal Luminous Green***	213 AB Jonquil Aurore Boreale	262 Rose Peach	502 <u>Fuchsia</u>
001 MBL Crystal Meridian Blue	213 SAT Jonquil Satin	263 Light Turquoise	508 <u>Rosaline</u>
001 METBL Crystal Metallic Blue	214 Peridot	266 Denim Blue	515 <u>Burgundy</u>
001 MLGLD Crystal Metallic Light Gold	215 Black Diamond	277 Purple Velvet	539 <u>Tanzanite</u>
001 MOL Crystal Moonlight	220 Smoked Topaz	280 Jet	542 <u>Padparadscha</u>
001 REDM Crystal Red Magma	220 SAT Smoked Topaz Satin	280 AB Jet Aurore Boreale	550 <u>Khaki</u>
001 ROGL Crystal Rose Gold	223 Light Rose	280 HEM Jet Hematite	652 <u>Marbled Yellow</u>
001 SINI Crystal Silver Night	223 AB Light Rose Aurore Boreale	280 NUT Jet Nut	653 <u>Marbled Black</u>
001 SSHA Crystal Silver Shade	226 Light Topaz	283 Provence Lavender	654 <u>Marbled Blue</u>
001 TAB Crystal Tabac	227 Light Siam	284 Greige	655 <u>Marbled Terracotta</u>
001 TRA HFT Crystal Transmission Hoftix Transparent	227 AB Light Siam Aurore Boreale	286 Mocca	657 <u>Marbled Light Grey</u>
001 VOL Crystal Volcano	227 SAT Light Siam Satin	288 Dark Indigo	
	228 Olivine	289 Indian Pink	

Alphabetical Order

Amethyst (204)	<u>Crystal Meridian Blue (001 MBL)</u>	Jet Hematite (280 HEM)	Olivine (228)
Aquamarine (202)	Crystal Metallic Blue (001 METBL)	Jet Nut (280 NUT)	<u>Pacific Opal (390)</u>
Black Diamond (215)	<u>Crystal Metallic Light Gold (001 MLGLD)</u>	Jonquil (213)	<u>Padparadscha (542)</u>
Blue Zircon (229)	Crystal Moonlight (001 MOL)	Jonquil Aurore Boreale (213 AB)	Peridot (214)
Blue Zircon Satin (229 SAT)	Crystal Red Magma (001 REDM)	Jonquil Satin (213 SAT)	Purple Velvet (277)
Burgundy (515)	<u>Crystal Rose Gold (001 ROGL)</u>	Khaki (550)	Rosaline (508)
Capri Blue (243)	<u>Crystal Silver Night (001 SINI)</u>	Light Amethyst (212)	Rose (209)
<u>Caribbean Blue Opal (394)</u>	Crystal Silver Shade (001 SSHA)	Light Colorado Topaz (246)	<u>Rose Peach (262)</u>
Chrysolite (238)	<u>Crystal Tabac (001 TAB)</u>	Light Grey Opal (383)	Provence Lavender (283)
<u>Chrysolite Opal (294)</u>	<u>Crystal Transmission Hoftix Transparent (001 TRA HFT)</u>	Light Peach (362)	Ruby (501)
Citrine (249)	Crystal Volcano (001 VOL)	Light Rose (223)	Sapphire (206)
Cobalt (369)	<u>Dark Indigo (288)</u>	Light Rose Aurore Boreale (223 AB)	Sapphire Satin (206 SAT)
Crystal (001)	<u>Dark Moss Green (260)</u>	Light Sapphire (211)	Siam (208)
<u>Crystal Antique Pink*** (001 ANTP)</u>	<u>Denim Blue (266)</u>	Light Siam (227)	Silk (391)
<u>Crystal Astral Pink (001 API)</u>	Emerald (205)	Light Siam Aurore Boreale (227 AB)	Smoked Topaz (220)
Crystal Aurore Boreale (001 AB)	Erinite (360)	Light Siam Satin (227 SAT)	Smoked Topaz Satin (220 SAT)
<u>Crystal Blue Shade (001 BLSH)</u>	<u>Fern Green (291)</u>	Light Silk (261)	Sun (248)
<u>Crystal Bronze Shade*** (001 BRSH)</u>	<u>Fireopal* (237)</u>	Light Topaz (226)	<u>Sunflower (292)</u>
Crystal Copper (001 COP)	Fuchsia (502)	Light Turquoise (263)	<u>Tangerine (259)</u>
<u>Crystal Cosmojet* (001 COS)</u>	<u>Greige (284)</u>	<u>Marbled Black (653)</u>	Tanzanite (539)
Crystal Dorado (001 DOR)	Hyacinth (236)	<u>Marbled Blue (654)</u>	Topaz (203)
<u>Crystal Golden Shadow (001 GSHA)</u>	Indian Pink (289)	<u>Marbled Light Grey (657)</u>	Topaz Aurore Boreale (203 AB)
Crystal Hoftix Transparent* (001 HFT)	<u>Indian Siam* (327)</u>	<u>Marbled Terracotta (655)</u>	<u>Vintage Rose (319)</u>
Crystal Iridescent Green (001 IRIG)	Jet (280)	<u>Marbled Yellow (652)</u>	White Opal (234)
Crystal Lilac Shadow (001 LISH)	Jet Aurore Boreale (280 AB)	<u>Mocca (286)</u>	
<u>Crystal Luminous Green*** (001 LUMG)</u>		Montana (207)	

This color chart is valid for the product group Transfers.

The displayed assortment is not entirely available for all products within the product group. For details on available colors and effects, please see the product matrix for the respective item.

Classic Colors: This color range offers a wide choice of traditional Swarovski crystal colors.

Exclusive Colors: This color range is offered exclusively by Swarovski.

The standard assortment of colors and effects may vary according to the product group.

Slight changes in shades are unavoidable. Colors may vary according to cut and shape.

* Only available in limited sizes.

** While stock lasts!

*** Crystals are not resistant to plating and similar processing.

Flat Backs for Transfers

FLAT BACKS HOTFIX

2000 Rose

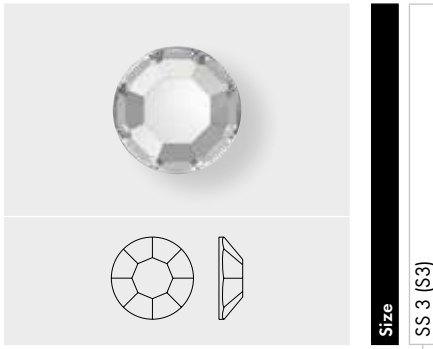

Size

SS 3 (S3)

Crystal

Crystal A HF (001)

Colors

Plain Colors

Amethyst A HF (204)

Aquamarine A HF (202)

Black Diamond A HF (215)

Jet A HF (280)

Light Colorado Topaz A HF (246)

Light Rose A HF (223)

Montana A HF (207)

Peridot A HF (214)

Smoked Topaz A HF (220)

Crystal Effects

Transparent Effects

Crystal AB A HF (001 AB)

Crystal Golden Shadow A HF (001 GSHA)

Crystal Silver Shade A HF (001 SSHA)

Metallic Effects

Crystal Metallic Blue A HF (001 METBL)

Crystal Metallic Light Gold A HF (001 MLGLD)

Crystal Rose Gold A HF (001 ROGL)

Color Effects

Metallic Effects

Jet Hematite A HF (280 HEM)

12 Transfers

CREATION STONES

2035 Chessboard Circle

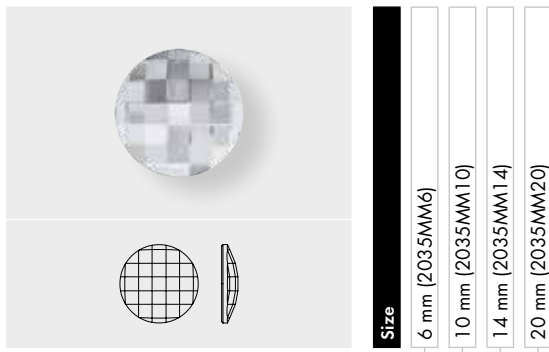

Size
6 mm (2035MM6)
10 mm (2035MM10)
14 mm (2035MM14)
20 mm (2035MM20)

Crystal	6 mm (2035MM6)	10 mm (2035MM10)	14 mm (2035MM14)	20 mm (2035MM20)
Crystal M HF (001)	■	■	■	■
Colors				
Plain Colors				
Jet M HF (280)	■	■	■	■
Crystal Effects				
Transparent Effects				
Crystal AB M HF (001 AB)	■	■	■	
Crystal Golden Shadow M HF (001 GSHA)	■	■	■	
Crystal Red Magma M HF (001 REDM)	■			

2037 Eclipse Flat Back

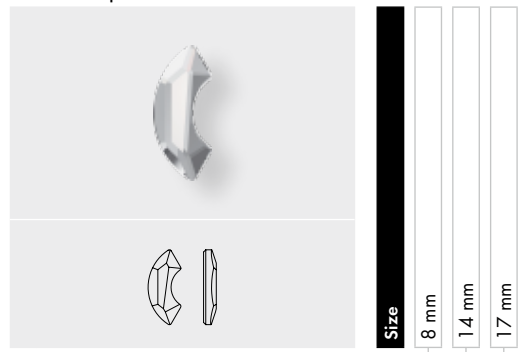

Size
8 mm
14 mm
17 mm

Crystal	8 mm	14 mm	17 mm
Crystal M HF (001)	■	■	■
Crystal Effects			
Transparent Effects			
Crystal Golden Shadow M HF (001 GSHA)	■	■	■

2038 XILION Rose Hotfix

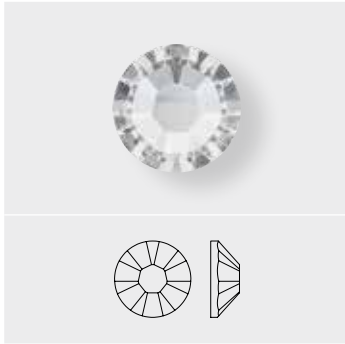

Size	SS 5	SS 6	SS 8	SS 10
------	------	------	------	-------

Crystal

- Crystal A HF (001)
- Crystal Hotfix Transparent (001 HFT)

Colors

Plain Colors

- Amethyst A HF (204)
- Aquamarine A HF (202)
- Black Diamond A HF (215)
- Blue Zircon A HF (229)
- Burgundy A HF (515)
- Capri Blue A HF (243)
- Chalkwhite A HF (279)
- Chrysolite A HF (238)
- Citrine A HF (249)
- Cobalt A HF (369)
- Dark Indigo A HF (288)
- Dark Moss Green F (260)
- Denim Blue A HF (266)
- Emerald A HF (205)
- Erinite A HF (360)
- Fern Green A HF (291)
- Fireopal A HF (237)
- Fuchsia A HF (502)
- Greige A HF (284)
- Hyacinth A HF (236)
- Indian Pink A HF (289)
- Indian Siam A HF (327)
- Jet A HF (280)
- Jonquil A HF (213)
- Khaki A HF (550)
- Light Amethyst A HF (212)
- Light Colorado Topaz A HF (246)
- Light Peach A HF (362)
- Light Rose A HF (223)
- Light Sapphire A HF (211)
- Light Siam A HF (227)
- Light Silk (261)
- Light Topaz A HF (226)
- Light Turquoise A HF (263)
- Mocca A HF (286)
- Montana A HF (207)



Size	SS 5	SS 6	SS 8	SS 10
------	------	------	------	-------

- Olivine A HF (228)
 - Padparadscha A HF (542)
 - Peridot A HF (214)
 - Provence Lavender A HF (283)
 - Purple Velvet A HF (277)
 - Rose A HF (209)
 - Rose Peach A HF (262)
 - Ruby A HF (501)
 - Sapphire A HF (206)
 - Siam A HF (208)
 - Silk A HF (391)
 - Smoked Topaz A HF (220)
 - Sun A HF (248)
 - Sunflower A HF (292)
 - Tangerine F (259)
 - Tanzanite A HF (539)
 - Topaz A HF (203)
 - Vintage Rose A HF (319)
- #### Opal Colors
- Caribbean Blue Opal A HF (394)
 - Light Grey Opal A HF (383)
 - Pacific Opal A HF (390)
 - White Opal A HF (234)
- #### Crystal Effects
- #### Transparent Effects
- Crystal AB A HF (001 AB)
 - Crystal Antique Pink A HF (001 ANTP)
 - Crystal Blue Shade A HF (001 BLSH)
 - Crystal Bronze Shade A HF (001 BRSH)
 - Crystal Copper A HF (001 COP)
 - Crystal Cosmojet A HF (001 COS)
 - Crystal Golden Shadow A HF (001 GSHA)
 - Crystal Lilac Shadow A HF (001 LISH)
 - Crystal Luminous Green A HF (001 LUMG)
 - Crystal Meridian Blue A HF (001 MBL)
 - Crystal Moonlight A HF (001 MOL)
 - Crystal Silver Night A HF (001 SINI)
 - Crystal Silver Shade A HF (001 SSHA)
 - Crystal Tabac A HF (001 TAB)
 - Crystal Transmission HFT (001 TRA HFT)
 - Crystal Volcano A HF (001 VOL)

2038

		SS 5	SS 6	SS 8	SS 10
Metallic Effects					
Crystal Dorado A HF (001 DOR)			■	■	■
Crystal Iridescent Green A HF (001 IRIG)			■	■	■
Crystal Metallic Blue A HF (001 METBL)			■	■	■
Crystal Metallic Light Gold A HF (001 MLGLD)			■	■	■
Crystal Rose Gold A HF (001 ROGL)			■	■	■
Color Effects					
Transparent Effects					
Blue Zircon Satin A HF (229 SAT)			■	■	■
Jet AB A HF (280 AB)			■	■	■
Jonquil AB A HF (213 AB)			■	■	■
Jonquil Satin A HF (213 SAT)			■	■	■
Light Rose AB A HF (223 AB)			■	■	■
Light Siam AB A HF (227 AB)			■	■	■
Light Siam Satin A HF (227 SAT)			■	■	■
Sapphire Satin A HF (206 SAT)			■	■	■
Smoked Topaz Satin A HF (220 SAT)			■	■	■
Metallic Effects					
Jet Hematite A HF (280 HEM)		■	■	■	■
Jet Nut A HF (280 NUT)			■	■	■

2038/B XILION Rose Flat Back

		SS 8	SS 10	SS 12	SS 16	SS 20
Colors						
Ceramics						
Marbled Black HFT (653)		■	■	■	■	■
Marbled Blue HFT (654)		■	■	■	■	■
Marbled Light Grey HFT (657)		■	■	■	■	■
Marbled Terracotta HFT (655)		■	■	■	■	■
Marbled Yellow HFT (652)		■	■	■	■	■

2078 XIRIUS Rose Hoflix

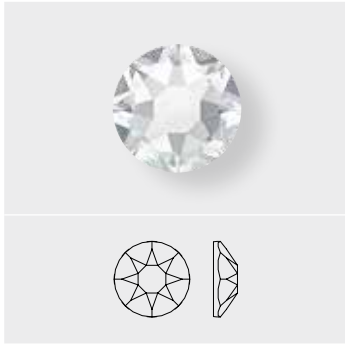

Size	SS 12	SS 16	SS 20	SS 30	SS 34	SS 40	SS 48
------	-------	-------	-------	-------	-------	-------	-------

Crystal

Crystal A HF (001)	■	■	■	■	■	■	■
Crystal Hoflix Transparent (001 HFT)		■					

Colors

Plain Colors

Amethyst A HF (204)	■	■	■	■	■		
Aquamarine A HF (202)	■	■	■	■	■		
Black Diamond A HF (215)	■	■	■	■	■		
Blue Zircon A HF (229)	■	■	■	■	■		
Burgundy A HF (515)	■	■	■		■		
Capri Blue A HF (243)	■	■	■	■	■		
Chalkwhite A HF (279)	■	■	■		■		
Chrysolite A HF (238)	■	■	■		■		
Citrine A HF (249)	■	■	■		■		
Cobalt A HF (369)	■	■	■		■		
Dark Indigo A HF (288)	■	■	■		■		
Dark Moss Green F (260)	■	■	■		■		
Denim Blue A HF (266)	■	■	■		■		
Emerald A HF (205)	■	■	■	■	■		
Erinite A HF (360)	■	■	■		■		
Fern Green A HF (291)	■	■	■		■		
Fireopal A HF (237)	■	■	■		■		
Fuchsia A HF (502)	■	■	■	■	■		
Greige A HF (284)	■	■	■		■		
Hyacinth A HF (236)	■	■	■		■		
Indian Pink A HF (289)	■	■	■		■		
Indian Siam A HF (327)	■	■	■		■		
Jet A HF (280)	■	■	■	■	■		
Jonquil A HF (213)	■	■	■	■	■		
Khaki A HF (550)	■	■	■		■		
Light Amethyst A HF (212)	■	■	■	■	■		
Light Colorado Topaz A HF (246)	■	■	■	■	■		
Light Peach A HF (362)	■	■	■		■		
Light Rose A HF (223)	■	■	■	■	■		
Light Sapphire A HF (211)	■	■	■	■	■		
Light Siam A HF (227)	■	■	■	■	■		
Light Silk (261)	■	■	■		■		
Light Topaz A HF (226)	■	■	■		■		
Light Turquoise A HF (263)	■	■	■		■		
Mocca A HF (286)	■	■	■		■		
Montana A HF (207)	■	■	■	■	■		

2078	Size	SS 12	SS 16	SS 20	SS 30	SS 34	SS 40	SS 48
	Olivine A HF (228)		■	■	■		■	
Padparadscha A HF (542)		■	■	■		■		
Peridot A HF (214)		■	■	■	■	■		
Provence Lavender A HF (283)		■	■	■		■		
Purple Velvet A HF (277)		■	■	■		■		
Rose A HF (209)		■	■	■	■	■		
Rose Peach A HF (262)		■	■	■		■		
Ruby A HF (501)		■	■	■	■	■		
Sapphire A HF (206)		■	■	■	■	■		
Siam A HF (208)		■	■	■	■	■		
Silk A HF (391)		■	■	■		■		
Smoked Topaz A HF (220)		■	■	■	■	■		
Sun A HF (248)		■	■	■		■		
Sunflower A HF (292)		■	■	■		■		
Tangerine F (259)		■	■	■		■		
Tanzanite A HF (539)		■	■	■		■		
Topaz A HF (203)		■	■	■	■	■		
Vintage Rose A HF (319)		■	■	■		■		
Opal Colors								
Caribbean Blue Opal A HF (394)		■	■	■		■		
Light Grey Opal A HF (383)		■	■	■		■		
Pacific Opal A HF (390)		■	■	■		■		
White Opal A HF (234)		■	■	■		■		
Crystal Effects								
Transparent Effects								
Crystal AB A HF (001 AB)		■	■	■	■	■	■	■
Crystal Antique Pink A HF (001 ANTP)		■	■	■		■		
Crystal Blue Shade A HF (001 BLSH)		■	■	■		■		
Crystal Bronze Shade A HF (001 BRSH)		■	■	■		■		
Crystal Copper A HF (001 COP)		■	■	■		■		
Crystal Cosmojet A HF (001 COS)		■	■					
Crystal Golden Shadow A HF (001 GSHA)		■	■	■		■		
Crystal Lilac Shadow A HF (001 LISH)		■	■	■		■		
Crystal Luminous Green A HF (001 LUMG)		■	■	■		■		
Crystal Meridian Blue A HF (001 MBL)		■	■	■		■		
Crystal Moonlight A HF (001 MOL)		■	■	■		■		
Crystal Silver Night A HF (001 SINI)		■	■	■		■		
Crystal Silver Shade A HF (001 SSHA)		■	■	■		■		
Crystal Tabac A HF (001 TAB)		■	■	■		■		
Crystal Transmission HFT (001 TRA HFT)		■	■	■		■		
Crystal Volcano A HF (001 VOL)		■	■	■				

2078		Size	SS 12	SS 16	SS 20	SS 30	SS 34	SS 40	SS 48
Metallic Effects									
	Crystal Dorado A HF (001 DOR)		■	■	■		■		
	Crystal Iridescent Green A HF (001 IRIG)		■	■	■		■		
	Crystal Metallic Blue A HF (001 METBL)		■	■	■		■		
	Crystal Metallic Light Gold A HF (001 MLGLD)		■	■	■		■		
	Crystal Rose Gold A HF (001 ROGL)		■	■	■		■		
Color Effects									
Transparent Effects									
	Blue Zircon Satin A HF (229 SAT)		■	■	■		■		
	Jet AB A HF (280 AB)		■	■	■		■		
	Jonquil AB A HF (213 AB)		■	■	■		■		
	Jonquil Satin A HF (213 SAT)		■	■	■		■		
	Light Rose AB A HF (223 AB)		■	■	■		■		
	Light Siam AB A HF (227 AB)		■	■	■		■		
	Light Siam Satin A HF (227 SAT)		■	■	■		■		
	Sapphire Satin A HF (206 SAT)		■	■	■		■		
	Smoked Topaz Satin A HF (220 SAT)		■	■	■		■		
Metallic Effects									
	Jet Hematite A HF (280 HEM)		■	■	■	■	■		
	Jet Nut A HF (280 NUT)		■	■	■		■		

Transfers

2180/4

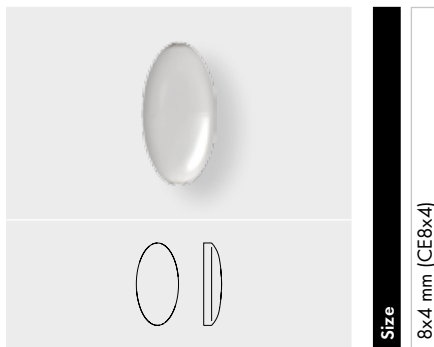

- Crystal**
- Crystal M HF (001)
- Colors**
- Plain Colors
- Jet M HF (280)
- Crystal Effects**
- Transparent Effects
- Crystal AB M HF (001 AB)
- Color Effects**
- Metallic Effects
- Jet Hematite M HF (280 HEM)

Flat Backs for Transfers

2200 Navette Flat Back

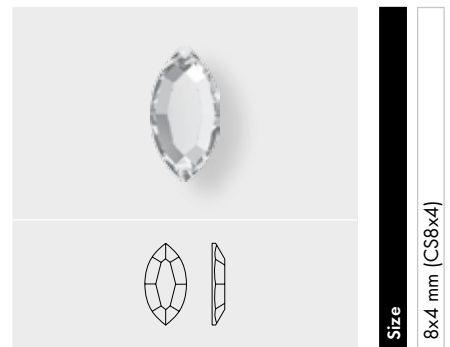

- Crystal**
- Crystal M HF (001)
- Colors**
- Plain Colors
- Jet M HF (280)
- Crystal Effects**
- Transparent Effects
- Crystal AB M HF (001 AB)
- Crystal Golden Shadow M HF (001 GSHA)
- Crystal Silver Shade M HF (001 SSHA)
- Color Effects**
- Metallic Effects
- Jet Hematite M HF (280 HEM)

Transfers

Flat Backs for Transfers

2204 Pure Leaf Flat Back

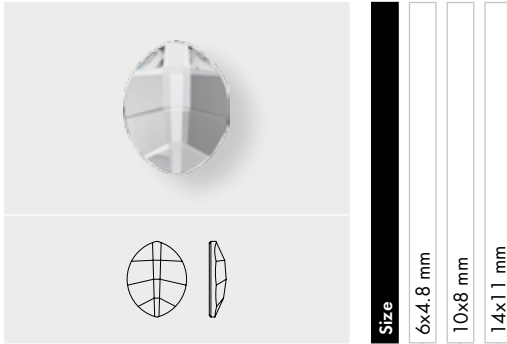

Size

6x4.8 mm

10x8 mm

14x11 mm

Crystal

Crystal M HF (001)

Colors

Plain Colors

Amethyst M HF (204)

Dark Moss Green M HF (260)

Emerald M HF (205)

Jet M HF (280)

Light Siam M HF (227)

Peridot M HF (214)

Crystal Effects

Transparent Effects

Crystal AB M HF (001 AB)

Crystal Blue Shade M HF (001 BLSH)

Crystal Golden Shadow M HF (001 GSHA)

Crystal Luminous Green M HF (001 LUMG)

Crystal Silver Night M HF (001 SINI)

2300 Drop Flat Back



Size

8x4.8 mm (CS8x5)

Crystal

Crystal M HF (001)

Colors

Plain Colors

Jet M HF (280)

Crystal Effects

Transparent Effects

Crystal AB M HF (001 AB)

Crystal Golden Shadow M HF (001 GSHA)

Color Effects

Metallic Effects

Jet Hematite M HF (280 HEM)

Transfers

Flat Backs for Transfers

2400 Square Flat Back

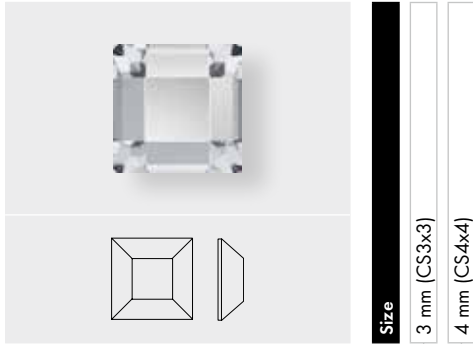

Crystal		
Crystal M HF (001)	■	■
Colors		
Plain Colors		
Jet M HF (280)	■	■
Crystal Effects		
Transparent Effects		
Crystal AB M HF (001 AB)	■	■
Crystal Golden Shadow M HF (001 GSHA)	■	■
Color Effects		
Metallic Effects		
Jet Hematite M HF (280 HEM)	■	■

Size
3 mm (CS3x3)
4 mm (CS4x4)

2483 Classic Square Flat Back

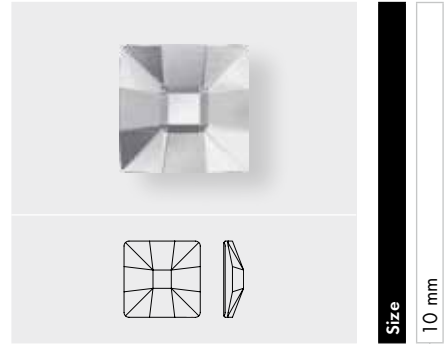

Crystal	
Crystal M HF (001)	■
Colors	
Plain Colors	
Black Diamond M HF (215)	■
Crystal Effects	
Transparent Effects	
Crystal Golden Shadow M HF (001 GSHA)	■

Size
10 mm

2493 Chessboard Flat Back

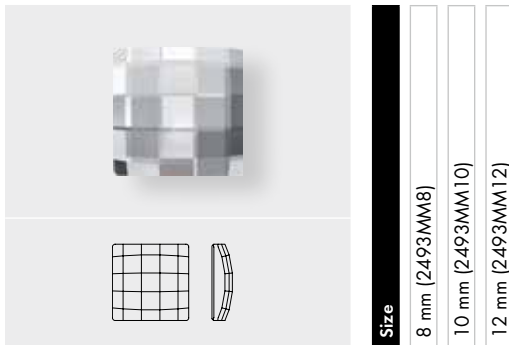

Crystal			
Crystal M HF (001)	■	■	■
Colors			
Plain Colors			
Jet M HF (280)	■	■	■
Crystal Effects			
Transparent Effects			
Crystal AB M HF (001 AB)	■	■	■
Crystal Golden Shadow M HF (001 GSHA)	■	■	■

Size
8 mm (2493MM8)
10 mm (2493MM10)
12 mm (2493MM12)

2510 Baguette Flat Back



Crystal	
Crystal M HF (001)	■
Colors	
Plain Colors	
Jet M HF (280)	■
Crystal Effects	
Transparent Effects	
Crystal AB M HF (001 AB)	■
Color Effects	
Metallic Effects	
Jet Hematite M HF (280 HEM)	■

Size
5x2.5 mm (CS5x3)

Transfers

Flat Backs for Transfers

2512/3*

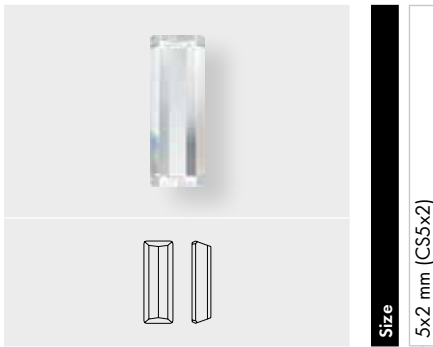

Size

5x2 mm (CS5x2)

- Crystal**
- Crystal M HF (001)
- Colors**
- Plain Colors
- Jet M HF (280)
- Crystal Effects**
- Transparent Effects
- Crystal AB M HF (001 AB)
- Color Effects**
- Metallic Effects
- Jet Hematite M HF (280 HEM)

2555 Cosmic Baguette Flat Back



Size

8x2.6 mm (2555MM8x2.6)
12x4 mm (2555MM12x4)
15x5 mm (2555MM15x5)

- Crystal**
- Crystal M HF (001)
- Colors**
- Plain Colors
- Jet M HF (280)
- Crystal Effects**
- Transparent Effects
- Crystal AB M HF (001 AB)
- Crystal Golden Shadow M HF (001 GSHA)
- Crystal Silver Shade M HF (001 SSHA)

12 Transfers

2585 Graphic Flat Back

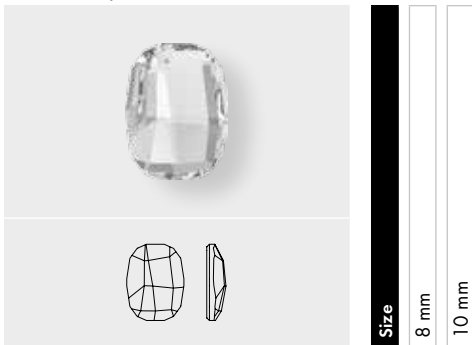

Size

8 mm
10 mm

- Crystal**
- Crystal M HF (001)
- Colors**
- Plain Colors
- Denim Blue M HF (266)

2610 Rectangle Flat Back

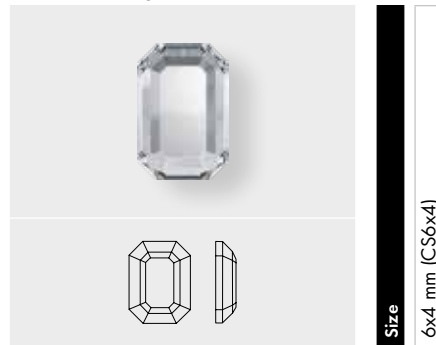

Size

6x4 mm (CS6x4)

- Crystal**
- Crystal M HF (001)
- Color Effects**
- Metallic Effects
- Jet Hematite M HF (280 HEM)

* Art. 2512/3 is only available for Transfers.

2611 Solaris Flat Back

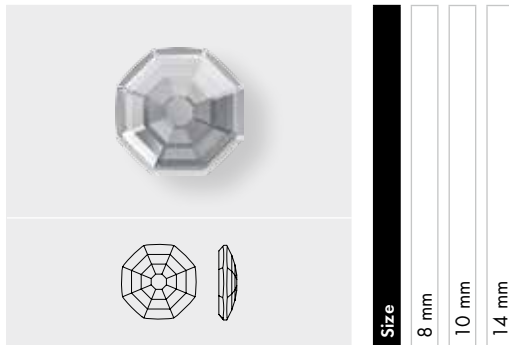

Crystal	8 mm	10 mm	14 mm
Crystal M HF (001)	■	■	■
Colors			
Plain Colors			
Aquamarine M HF (202)	■	■	■
Jet M HF (280)	■	■	■
Light Rose M HF (223)	■	■	■
Crystal Effects			
Transparent Effects			
Crystal AB M HF (001 AB)	■	■	■
Crystal Golden Shadow M HF (001 GSHA)	■	■	■
Crystal Luminous Green M HF (001 LUMG)	■	■	■
Crystal Silver Night M HF (001 SINI)	■	■	■
Metallic Effects			
Crystal Iridescent Green M HF (001 IRIG)	■	■	■

2611/G Solaris Flat Back partly frosted

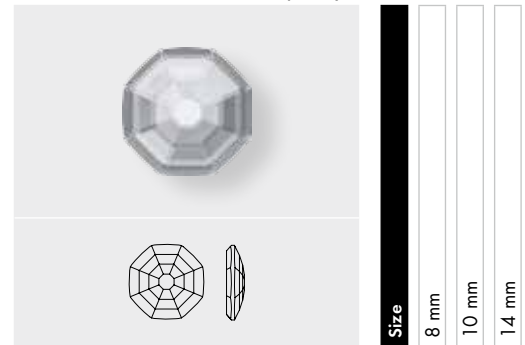

Crystal	8 mm	10 mm	14 mm
Crystal M HF (001)	■	■	■
Colors			
Plain Colors			
Aquamarine M HF (202)	■	■	■
Jet M HF (280)	■	■	■
Light Rose M HF (223)	■	■	■
Crystal Effects			
Transparent Effects			
Crystal AB M HF (001 AB)	■	■	■
Crystal Golden Shadow M HF (001 GSHA)	■	■	■
Crystal Luminous Green M HF (001 LUMG)	■	■	■
Crystal Silver Night M HF (001 SINI)	■	■	■
Metallic Effects			
Crystal Iridescent Green M HF (001 IRIG)	■	■	■

Transfers

Flat Backs for Transfers

2708 Molecule Flat Back

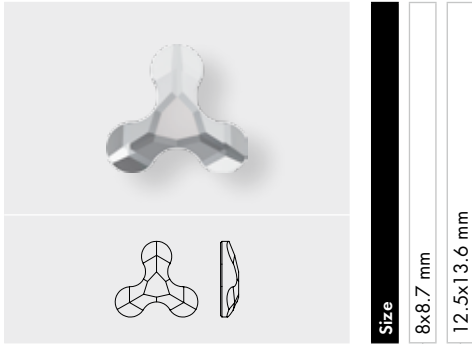

- Crystal**
- Crystal M HF (001)
- Colors**
- Plain Colors**
- Amethyst M HF (204)
- Blue Zircon M HF (229)
- Dark Moss Green M HF (260)
- Denim Blue M HF (266)
- Fuchsia M HF (502)
- Jet M HF (280)
- Light Silk M HF (261)
- Light Turquoise M HF (263)
- Crystal Effects**
- Transparent Effects**
- Crystal AB M HF (001 AB)
- Crystal Antique Pink M HF (001 ANTP)
- Crystal Blue Shade M HF (001 BLSH)
- Crystal Golden Shadow M HF (001 GSHA)
- Crystal Silver Night M HF (001 SINI)
- Metallic Effects**
- Crystal Iridescent Green M HF (001 IRIG)
- Crystal Rose Gold M HF (001 ROGL)

2711 Triangle Flat Back

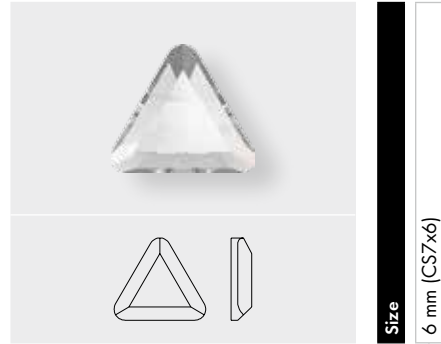

- Crystal**
- Crystal M HF (001)
- Colors**
- Plain Colors**
- Jet M HF (280)
- Crystal Effects**
- Transparent Effects**
- Crystal AB M HF (001 AB)
- Color Effects**
- Metallic Effects**
- Jet Hematite M HF (280 HEM)

Transfers

Flat Backs for Transfers

2720 Cosmic Delta Flat Back

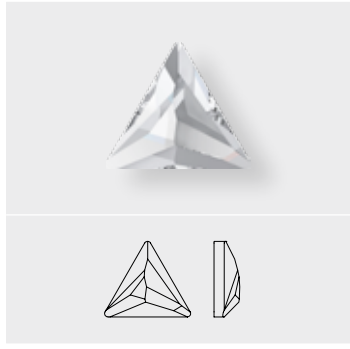

Size	7.5 mm	9 mm	12.5 mm
Crystal			
Crystal M HF (001)	■	■	■
Colors			
Plain Colors			
Jet M HF (280)	■	■	
Crystal Effects			
Transparent Effects			
Crystal AB M HF (001 AB)	■		
Crystal Silver Shade M HF (001 SSHA)	■	■	■

2728 Marguerite Flat Back

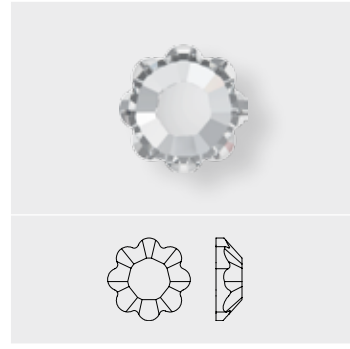

Size	SS 10 (CB10)	SS 16 (CB16)	SS 20 (CB20)	SS 34 (CB34)
Crystal				
Crystal M HF (001)	■	■	■	■
Crystal Effects				
Transparent Effects				
Crystal AB M HF (001 AB)	■	■	■	■

2770 Wing Flat Back

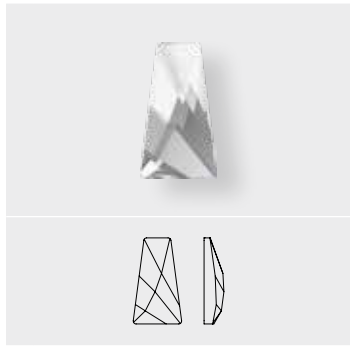

Size	6x3.5 mm (2770MM6x3.5)	12x7 mm (2770MM12x7)	16x9.5 mm (2770MM16x9.5)
Crystal			
Crystal M HF (001)	■	■	
Colors			
Plain Colors			
Black Diamond M HF (215)	■		
Jet M HF (280)	■	■	■
Crystal Effects			
Transparent Effects			
Crystal AB M HF (001 AB)	■		
Crystal Golden Shadow M HF (001 GSHA)	■	■	■

2788 Wave Flat Back

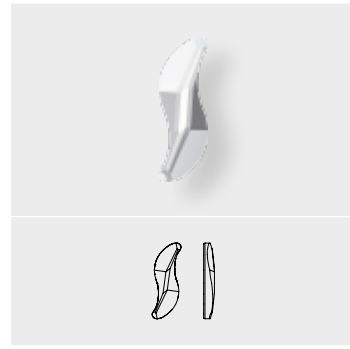

Size	8 mm	10 mm	14 mm
Crystal			
Crystal M HF (001)	■	■	■
Crystal Effects			
Transparent Effects			
Crystal AB M HF (001 AB)	■	■	■
Crystal Blue Shade M HF (001 BLSH)	■	■	■

Transfers

Flat Backs for Transfers

2797 Diamond Leaf Flat Back

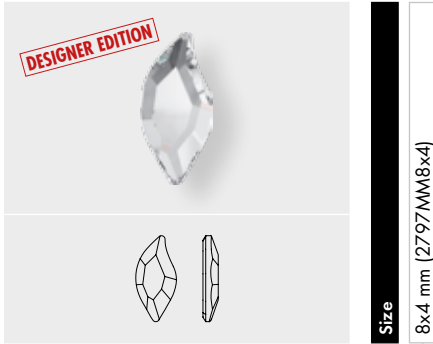

Size

8x4 mm (2797MM8x4)

Crystal

Crystal M HF (001)

Crystal Effects

Transparent Effects

Crystal AB M HF (001 AB)

2808 Heart Flat Back

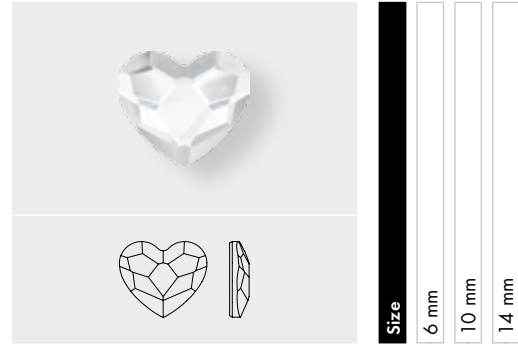

Size

6 mm

10 mm

14 mm

Crystal

Crystal M HF (001)

Colors

Plain Colors

Dark Moss Green M HF (260)

Denim Blue M HF (266)

Fuchsia M HF (502)

Jet M HF (280)

Light Siam M HF (227)

Light Silk M HF (261)

Rosaline M HF (508)

Crystal Effects

Transparent Effects

Crystal AB M HF (001 AB)

Crystal Antique Pink M HF (001 ANTP)

Crystal Astral Pink M HF (001 API)

Crystal Golden Shadow M HF (001 GSHA)

Metallic Effects

Crystal Rose Gold M HF (001 ROGL)

Transfers

Flat Backs for Transfers

2817 Star Flat Back

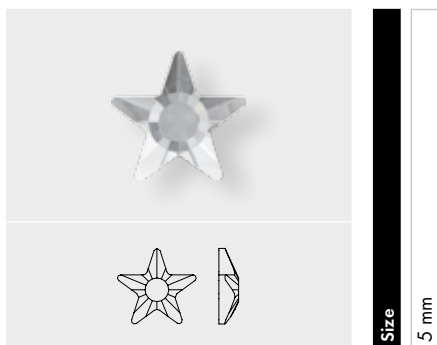

Size
5 mm

- Crystal**
- Crystal M HF (001)
- Colors**
- Plain Colors**
- Denim Blue M HF (266)
- Jet M HF (280)
- Rose Peach M HF (262)
- Crystal Effects**
- Transparent Effects**
- Crystal AB M HF (001 AB)
- Crystal Golden Shadow M HF (001 GSHA)
- Crystal Silver Night M HF (001 SINI)
- Metallic Effects**
- Crystal Iridescent Green M HF (001 IRIG)
- Crystal Rose Gold M HF (001 ROGL)
- Color Effects**
- Metallic Effects**
- Jet Hematite M HF (280 HEM)

2855 Butterfly Flat Back

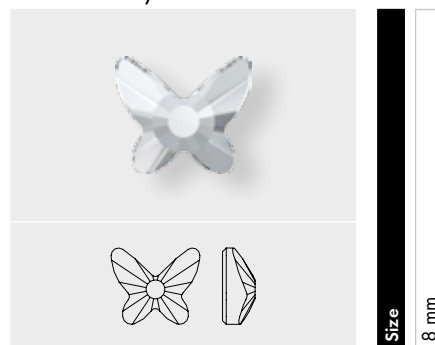

Size
8 mm

- Crystal**
- Crystal M HF (001)
- Colors**
- Plain Colors**
- Amethyst M HF (204)
- Denim Blue M HF (266)
- Jet M HF (280)
- Light Rose M HF (223)
- Rose Peach M HF (262)
- Crystal Effects**
- Transparent Effects**
- Crystal AB M HF (001 AB)
- Crystal Golden Shadow M HF (001 GSHA)
- Crystal Luminous Green M HF (001 LUMG)
- Crystal Silver Night M HF (001 SINI)

Transfers

Flat Backs for Transfers

2855/G Butterfly Flat Back fully frosted

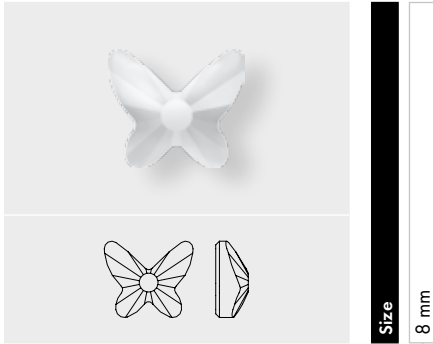

Size
8 mm

- Crystal**
- Crystal M HF FF (001)
- Colors**
- Plain Colors**
- Amethyst M HF FF (204)
- Denim Blue M HF FF (266)
- Light Rose M HF FF (223)
- Rose Peach M HF FF (262)

2858 Bow Tie Flat Back

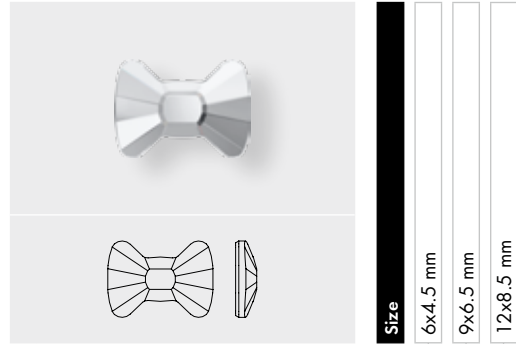

Size
6x4.5 mm
9x6.5 mm
12x8.5 mm

- Crystal**
- Crystal M HF (001)
- Colors**
- Plain Colors**
- Denim Blue M HF (266)
- Jet M HF (280)
- Light Amethyst M HF (212)
- Light Siam M HF (227)
- Tangerine M HF (259)
- Vintage Rose M HF (319)
- Opal Colors**
- White Opal M HF (234)
- Crystal Effects**
- Transparent Effects**
- Crystal AB M HF (001 AB)
- Crystal Golden Shadow M HF (001 GSHA)
- Crystal Luminous Green M HF (001 LUMG)
- Crystal Silver Night M HF (001 SINI)
- Metallic Effects**
- Crystal Iridescent Green M HF (001 IRIG)

CREATION STONES

2080/4 Cabochon

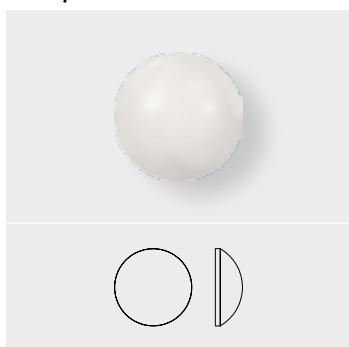

Size	SS 10 (P3)	SS 16 (P4)	SS 34 (P7)
------	------------	------------	------------

Colors

Plain Colors

Jet M HF (280)	<input type="checkbox"/>	<input type="checkbox"/>	<input type="checkbox"/>
----------------	--------------------------	--------------------------	--------------------------

Crystal Pearl Colors

Crystal Bronze Pearl HF (001 295)	<input type="checkbox"/>	<input type="checkbox"/>	<input type="checkbox"/>
-----------------------------------	--------------------------	--------------------------	--------------------------

Crystal Creampearl HF (001 291)	<input type="checkbox"/>	<input type="checkbox"/>	<input type="checkbox"/>
---------------------------------	--------------------------	--------------------------	--------------------------

Crystal Dark Grey Pearl HF (001 617)	<input type="checkbox"/>	<input type="checkbox"/>	<input type="checkbox"/>
--------------------------------------	--------------------------	--------------------------	--------------------------

Crystal Light Grey Pearl HF (001 616)	<input type="checkbox"/>	<input type="checkbox"/>	<input type="checkbox"/>
---------------------------------------	--------------------------	--------------------------	--------------------------

Crystal Rosaline Pearl HF (001 294)	<input type="checkbox"/>	<input type="checkbox"/>	<input type="checkbox"/>
-------------------------------------	--------------------------	--------------------------	--------------------------

Crystal White Pearl HF (001 650)	<input type="checkbox"/>	<input type="checkbox"/>	<input type="checkbox"/>
----------------------------------	--------------------------	--------------------------	--------------------------

Gemcolors

Crystal Jade Pearl HF (001 715)	<input type="checkbox"/>	<input type="checkbox"/>	<input type="checkbox"/>
---------------------------------	--------------------------	--------------------------	--------------------------

Crystal Pink Coral Pearl HF (001 716)	<input type="checkbox"/>	<input type="checkbox"/>	<input type="checkbox"/>
---------------------------------------	--------------------------	--------------------------	--------------------------

Crystal Red Coral Pearl HF (001 718)	<input type="checkbox"/>	<input type="checkbox"/>	<input type="checkbox"/>
--------------------------------------	--------------------------	--------------------------	--------------------------

Crystal Turquoise Pearl HF (001 709)	<input type="checkbox"/>	<input type="checkbox"/>	<input type="checkbox"/>
--------------------------------------	--------------------------	--------------------------	--------------------------

Crystal Effects

Transparent Effects

Crystal Golden Shadow HF (001 GSHA)	<input type="checkbox"/>	<input type="checkbox"/>	<input type="checkbox"/>
-------------------------------------	--------------------------	--------------------------	--------------------------

Crystal Nacre HF (001 191)	<input type="checkbox"/>	<input type="checkbox"/>	<input type="checkbox"/>
----------------------------	--------------------------	--------------------------	--------------------------

Metallic Effects

Crystal Chrom V HF (001 CHRMV)	<input type="checkbox"/>	<input type="checkbox"/>	<input type="checkbox"/>
--------------------------------	--------------------------	--------------------------	--------------------------

Crystal Color Effects

Metallic Effects

Jet Hematite M HF (280 HEM)	<input type="checkbox"/>	<input type="checkbox"/>	<input type="checkbox"/>
-----------------------------	--------------------------	--------------------------	--------------------------

DIAMONDS

1360 (with art. 1028 XILION Chaton)



1360 (with art. 1088 XIRIUS Chaton)

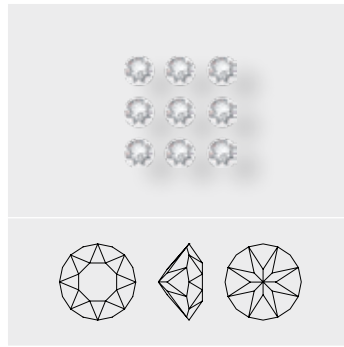





























12 Transfers

1360		Size	PP 7 (PP7 with art. 1028 XILION Chaton)	PP 12 (PP12 with art. 1028 XILION Chaton)	PP 17 (PP17 with art. 1088 XIRIUS Chaton)
Crystal					
Crystal (001)					
Colors					
Plain Colors					
Amethyst (204)					
Aquamarine (202)					
Dark Indigo (288)					
Dark Moss Green F (260)					
Denim Blue (266)					
Emerald (205)					
Fern Green (291)					
Jet (280)					
Indian Pink (289)					
Light Colorado Topaz (246)					
Light Peach (362)					
Light Rose (223)					
Light Sapphire (211)					
Light Siam (227)					
Light Silk (261)					
Light Turquoise (263)					
Padparadscha (542)					
Peridot (214)					

1360		Size	PP 7 (PP7 with art. 1028 XILION Chaton)	PP 12 (PP12 with art. 1028 XILION Chaton)	PP 17 (PP17 with art. 1088 XIRIUS Chaton)
Provence Lavender (283)					
Rose Peach (262)					
Sapphire (206)					
Siam (208)					
Smoked Topaz (220)					
Sunflower (292)					
Tangerine (259)					
Tanzanite (539)					
Topaz (203)					
Vintage Rose (319)					
Crystal Effects					
Transparent Effects					
Crystal AB (001 AB)					
Crystal Antique Pink (001 ANTP)					
Crystal Blue Shade (001 BLSH)					
Crystal Lilac Shadow (001 LISH)					
Crystal Luminous Green (001 LUMG)					
Crystal Silver Shade (001 SSHA)					
Metallic Effects					
Crystal Iridescent Green (001 IRIG)					
Crystal Metallic Blue (001 METBL)					
Crystal Rose Gold (001 ROGL)					

METALLICS

	3490 3490/006 (M2*)		3490 3490/008 (M8)		3490 3490/002 (M10x3)
	3490 3490/012 (M2.5*)		3490 3490/009 (MZ8*)		3490 3490/010 (M7x3*)
	3490 3490/300 (M3*)		3490 3490/007 (M10)		3490 3490/003 (MST)
	3490 3490/400 (M4*)		3490 3490/001 (M7x7)		3490 3490/005 (M12x6)
	3490 3490/600 (M6)		3490 3490/011 (M3x3*)		3490 3490/013 (M9x4)
	Gold polished stucco (061)		Silver polished stucco (062)		Gun metal brushed (086)
	Gold brushed (081)		Silver brushed (082)		Gun metal polished (096)
	Gold polished (091)		Silver polished (092)		
	Bronze brushed (084)		Copper brushed (080)		Black polished (070)
	Bronze polished (094)		Copper polished (090)		Blue brushed (071)

* Stucco effects are not available for this size.

ARTICLE EXPLANATION

12 814

04



C	001 414/001GSHA/220/220/ 001GSHA/286
E	P3/2770MM60X35/S3/S5/S6/S6
S	~39x51
M	49 PCS
	77%

12 710

S/S 2011

07/03



C	001AB/502
E	S3/S6
S	~81x64
M	18 PCS
	50%

12 814	04	C	E	S	M	77%
Article number	This motif is shown on flag number 4.	Color assortment For details, please refer to the color and product charts at the beginning of this chapter. Color code 1 (001 414) corresponds to element 1 (P3); color code 2 (001 GSHA) corresponds to element 2 (2770MM60x35) etc.	Elements For details of stone sizes and element codes, please refer to the color and product charts at the beginning of this chapter.	Motif size in mm	Minimum order quantity in pieces (PCS)	Documentation size in %
12 710	07/03	C	E	S	M	50%
Article number	In this case, two numbers are indicated. The first number (07) stands for the number of the flag in the Crystal Inspirations Collection on which the Transfer is shown. The second number (03) refers to the flag number in the Standard Flag Collection.	Color assortment For details, please refer to the color and product charts at the beginning of this chapter. Color code 1 (001 AB) corresponds to element 1 (S3); color code 2 (502) corresponds to element 2 (S6) etc. Metallics are separated from crystal colors with hyphens.	Elements For details of stone sizes and element codes, please refer to the color and product charts at the beginning of this chapter. Codes for Metallics are separated from crystals with hyphens.	Motif size in mm	Minimum order quantity in pieces (PCS)	Documentation size in %

ORDERING EXAMPLE & PRODUCT VARIETY EXPLANATION

12 710	001 AB	502
Article number	Crystal color corresponding to element 1; color of most frequently used element in the motif	Crystal color corresponding to element 2; color of second most frequently used element in the motif
	Please see the respective product charts at the beginning of this chapter for all available code references.	

STANDARD COLLECTION

Transfers are available in a range of sizes and motifs to suit a variety of segments. Numerous motifs and rows in all sizes and styles provide a creative pool of design ideas. The assortment is a balanced mix of large and small motifs in all price categories, as well as a good representation of all the different elements that can be used in Transfer motifs.



10 010



C	206
E	PP7
S	~14x14
M	42 PCS
100%	

10 048

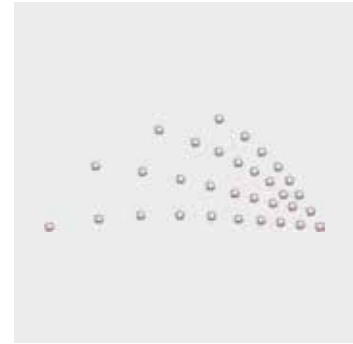

C	001AB
E	PP7
S	~36x18
M	15 PCS
100%	

10 049



C	001AB
E	PP7
S	~36x18
M	15 PCS
100%	

10 167

04



C	001 191/001GSHA/001GSHA
E	P3/S6/S10
S	~73x67
M	36 PCS
55%	

10 248

03



C	090-362/391
E	M2-S6/S10
S	~43x80
M	55 PCS
50%	

10 256

03



C	001AB
E	S10
S	~45x45
M	72 PCS
80%	

10 262

03



C	092/082/092-001AB
E	M2/M3/MST-S6
S	~118x69
M	24 PCS
35%	

10 272

03



C	001AB/001
E	S6/S10
S	~63x73
M	36 PCS
55%	

10 368

07

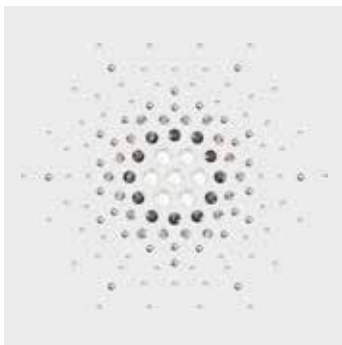

C	001/001SSHA/284/001SINI/001MOL
E	S6/S10/S16/S20/S34
S	~116x100
M	16 PCS
35%	

10 380

08



C	001 295/001GSHA
E	P4/S10
S	~275x190
M	4 PCS
19%	

10 381

09

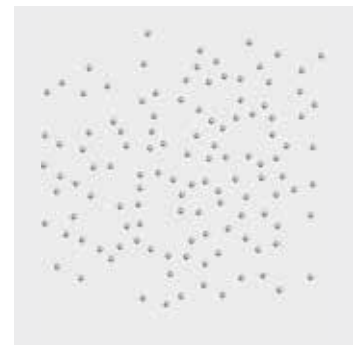

C	001MOL/001SSHA
E	S6/S16
S	~215x187
M	5 PCS
20%	

10 385 08



C	001AB
E	S16
S	~230x230
M	4 PCS
	19%

10 399



C	091/091/081-280HEM/280AB
E	M2/M2/M3-S6/S34
S	~250x224
M	4 PCS
	17%

10 400

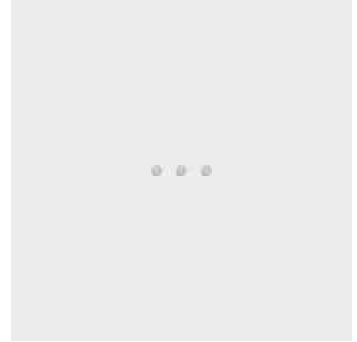

C	001
E	PP7
S	~487x2 (163 SEG/ROW)
M	15 ROWS
	100%

10 402 13



C	001
E	S6
S	~982x2 (153 SEG/ROW)
M	18 ROWS
	100%

10 403 13

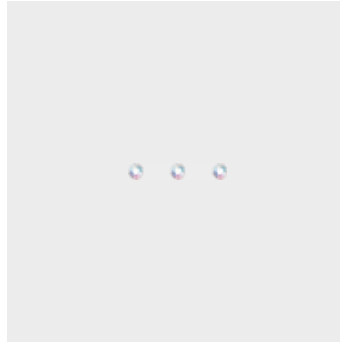

C	001AB
E	S6
S	~987x2 (180 SEG/ROW)
M	18 ROWS
	100%

10 404

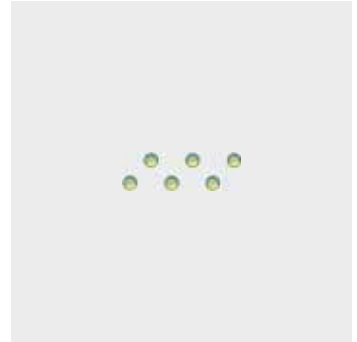

C	390
E	S6
S	~990x5 (182 SEG/ROW)
M	16 ROWS
	100%

10 405 13

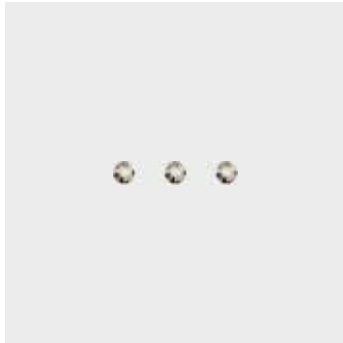

C	001SSHA
E	S10
S	~984x3 (152 SEG/ROW)
M	16 ROWS
	100%

10 406 13



C	001SINI
E	S10
S	~976x3 (99 SEG/ROW)
M	15 ROWS
	100%

10 408 13

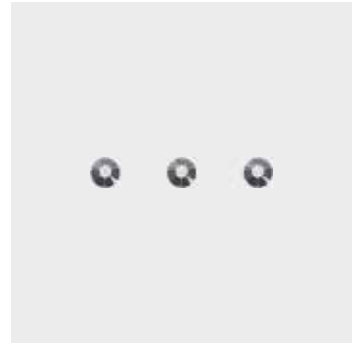

C	280HEM
E	S16
S	~980x4 (98 SEG/ROW)
M	12 ROWS
	100%

10 409 13



C	001GSHA
E	CS8x4
S	~988x4 (49 SEG/ROW)
M	14 ROWS
	80%

10 411 13

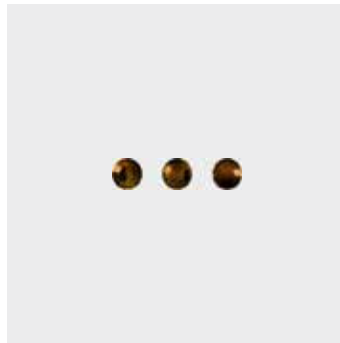

C	001BRSH
E	S16
S	~979x4 (151 SEG/ROW)
M	12 ROWS
	100%

10 412 13

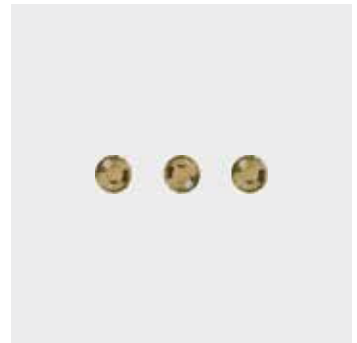

C	001MLGLD
E	S20
S	~974x5 (116 SEG/ROW)
M	12 ROWS
	100%

Transfers

Standard Collection

10 413 **13**

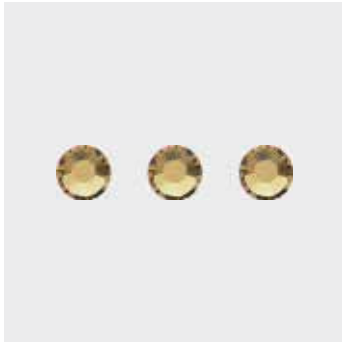

C	001GSHA
E	S34
S	~979x7 (82 SEG/ROW)
M	9 ROWS
	100%

10 414 **13**



C	001 295
E	P3
S	~983x3 (99 SEG/ROW)
M	13 ROWS
	100%

10 417

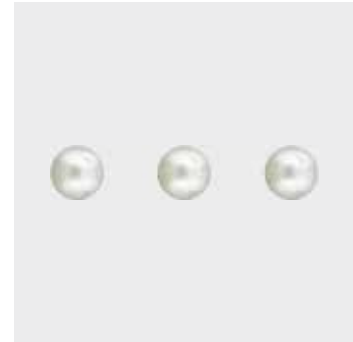

C	001 191
E	P7
S	~980x7 (70 SEG/ROW)
M	10 ROWS
	100%

10 423 **10**

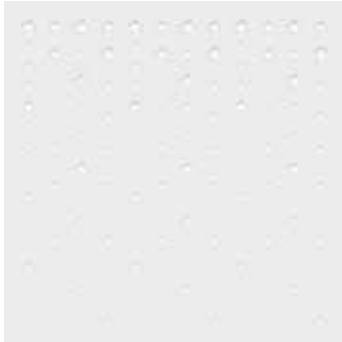

C	001MOL/001MOL/001MOL
E	S10/S16/S20
S	~977x101 (28 SEG/ROW)
M	2 ROWS
	40%

10 425 **13**

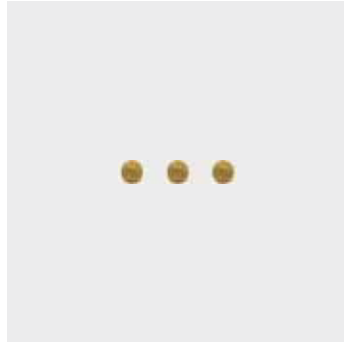

C	081
E	M2.5
S	~983x3 (197 SEG/ROW)
M	19 ROWS
	100%

10 426 **13**



C	080/090
E	M2/M3
S	~982x3 (123 SEG/ROW)
M	17 ROWS
	100%

10 427



C	086
E	M3
S	~981x3 (164 SEG/ROW)
M	16 ROWS
	100%

10 429 **13**

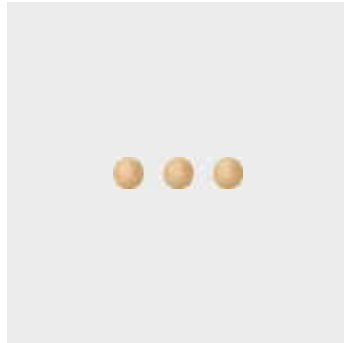

C	094
E	M4
S	~986x3 (152 SEG/ROW)
M	16 ROWS
	100%

10 430

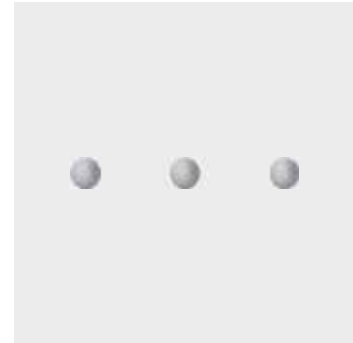

C	096
E	M4
S	~979x4 (76 SEG/ROW)
M	16 ROWS
	100%

10 431 **13**



C	086
E	M3x3
S	~985x6 (176 SEG/ROW)
M	15 ROWS
	100%

10 432 **13**



C	071
E	M7x3
S	~985x3 (116 SEG/ROW)
M	15 ROWS
	100%

10 434

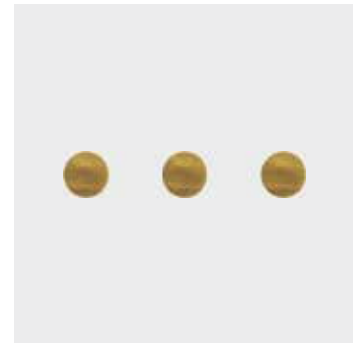

C	081
E	M6
S	~981x6 (76 SEG/ROW)
M	15 ROWS
	100%

10 435 13

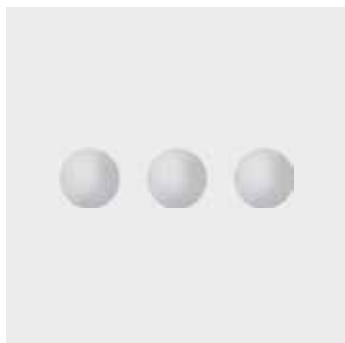

C	092
E	M8
S	~986x8 (86 SEG/ROW)
M	12 ROWS
	100%

10 436

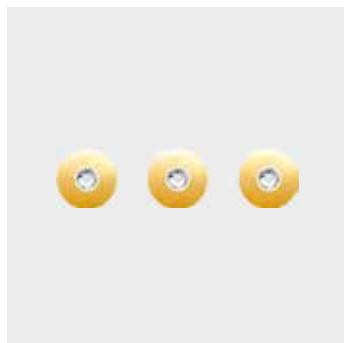

C	081-001
E	MZ8-S10
S	~980x8 (82 SEG/ROW)
M	12 ROWS
	100%

10 437



C	086
E	M10
S	~985x10 (66 SEG/ROW)
M	11 ROWS
	100%

10 439 13



C	070
E	M7x7
S	~980x7 (82 SEG/ROW)
M	13 ROWS
	100%

10 441



C	082
E	M10x3
S	~986x3 (66 SEG/ROW)
M	17 ROWS
	100%

10 513

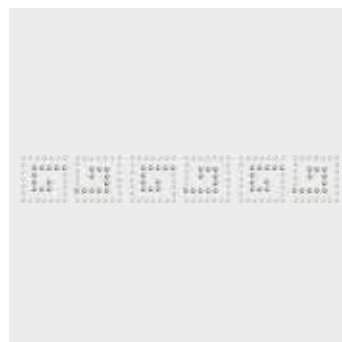

C	092-001SSHA
E	M2-S6
S	~981x18 (24 SEG/ROW)
M	7 ROWS
	35%

10 515



C	001/001AB/001MOL
E	S6/S10/S16
S	~982x32 (94 SEG/ROW)
M	5 ROWS
	100%

10 549

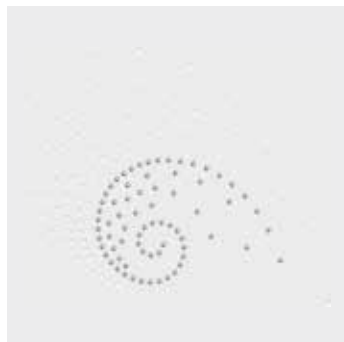

C	001SSHA/001MOL
E	S6/S10
S	~116x98
M	18 PCS
	35%

10 912



C	091-001GSHA/001MOL
E	M2-S6/S10
S	~980x23 (8 SEG/ROW)
M	6 ROWS
	30%

10 933

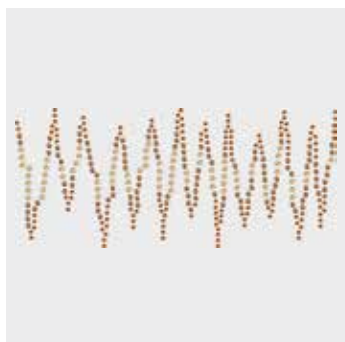

C	220/001COP/246
E	S6/S8/S10
S	~157x68
M	18 PCS
	27%

10 934



C	001AB/001/234
E	S6/S10/S16
S	~63x62
M	42 PCS
	60%

10 937

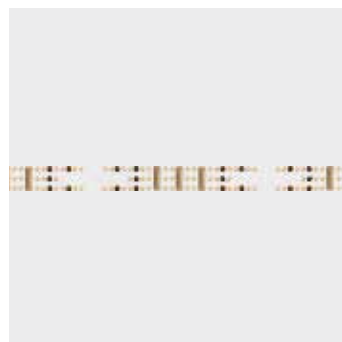

C	094/084-001BRSH
E	M2/M10x3-S8
S	~980x11 (13 SEG/ROW)
M	10 ROWS
	30%

Transfers

Standard Collection

10 950



C	001MOL/234/001COS
E	S6/S10/S16
S	~186x217
M	5 PCS
	20%

10 980



C	001/001AB
E	S6/S10
S	~979x15 (10 SEG/ROW)
M	10 ROWS
	35%

10

10 993

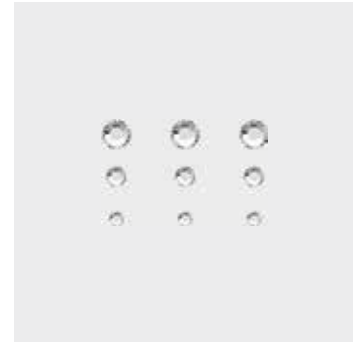

C	001/001/001
E	S6/S10/S16
S	~980x14 (109 SEG/ROW)
M	10 ROWS
	100%

10

11 082



C	001/234
E	S8/S10
S	~75x73
M	39 PCS
	50%

11 092



C	211/266/206SAT/207/001METBL
E	S6/S8/S10/S10/S16
S	~114x63
M	27 PCS
	35%

11

11 094



C	206SAT/001SINI/211/206
E	S10/S10/S10/S10
S	~52x52
M	48 PCS
	70%

11

11 167

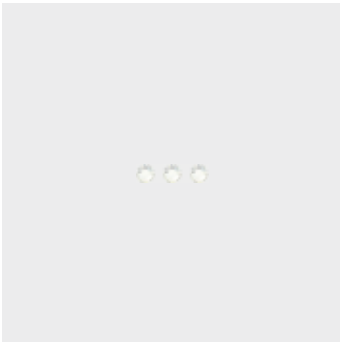

C	001MOL
E	S8
S	~982x2 (281 SEG/ROW)
M	18 ROWS
	100%

13

11 172



C	001GSHA
E	S6
S	~980x23 (20 SEG/ROW)
M	7 ROWS
	30%

12

11 190



C	091-001GSHA
E	M2-S6
S	~984x23 (48 SEG/ROW)
M	7 ROWS
	65%

11 259



C	096/092-001COP/213SAT/227AB
E	M2/M3-S6/S6/S10
S	~76x93
M	22 PCS
	45%

11 473

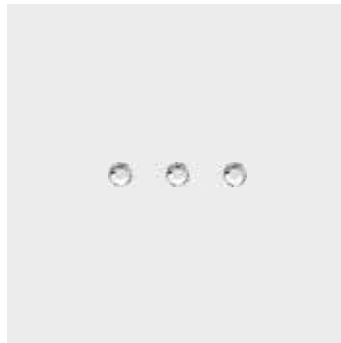

C	001
E	S12
S	~978x3 (131 SEG/ROW)
M	14 ROWS
	100%

11

11 475



C	211
E	S16
S	~32x32
M	84 PCS
	100%

11

11 478 05



C 001AB/001AB/205/319/360
 E CE8x4/S6/S8/S12/S16
 S ~78x163
 M 12 PCS 25%

11 494



C 086/096-001GSHA/277/001SSHA
 E M7x7/M7x3-S6/S8/S8
 S ~53x66
 M 64 PCS 60%

11 539



C 001ANTP/205/204/283/360/283
 E S6/S6/S6/S8/S8/S10
 S ~216x46
 M 17 PCS 20%

11 557



C 362/001AB
 E PP7/S6
 S ~22x62
 M 28 PCS 60%

11 575



C 208/280HEM/001MOL001SSHA/
 001SINI/284
 E S6/S6/S6/S10/S10/S16
 S ~94x94
 M 18 PCS 40%

11 576



C 001MOL/001SSHA/001SINI
 E S6/S8/S10
 S ~980x3 (33 SEG/ROW)
 M 16 ROWS 55%

11 578



C 001BRSH/001SINI/001METBL/288
 E S6/S8/S10/S12
 S ~87x29
 M 50 PCS 45%

11 606



C 001 295/001SSHA/001MOL/
 001GSHA/001MLGLD
 E P3/S6/S8/S10/S16
 S ~977x13 (29 SEG/ROW)
 M 8 ROWS 40%

11 609

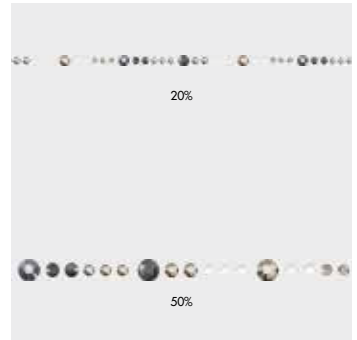

C 001SSHA/284/001MOL/001SINI/001SSHA/
 001MOL/280HEM/001SSHA/001SINI
 E S16/S16/S16/S20/S20/S20/S34/S34/S34
 S ~938x7 (8 SEG/ROW)
 M 9 ROWS

11 625

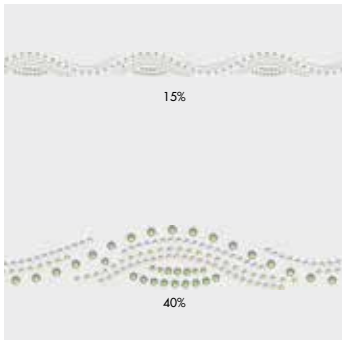

C 234/001/390/390/390
 E S6/S6/S6/S8/S10
 S ~944x21 (9 SEG/ROW)
 M 7 ROWS

11 633



C 220/286/001GSHA/001MOL/280/
 280HEM/001COS
 E S6/S6/S6/S6/S6/S6/S6
 S ~127x170
 M 7 PCS 25%

11 692

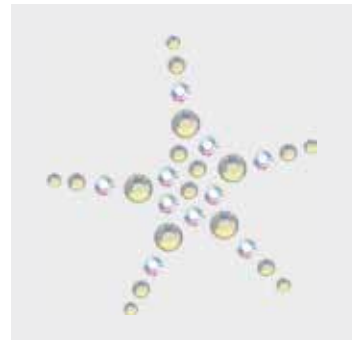

C 234/234/001AB/234
 E S6/S8/S10/S16
 S ~36x37
 M 110 PCS 100%

Transfers

Standard Collection

11 721

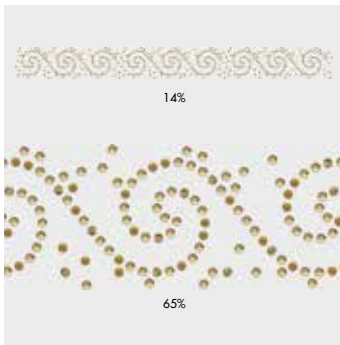

C	081-001GSHA/001MLGLD
E	M2-S6/S6
S	~895x29 (9 SEG/ROW)
M	5 ROWS

11 723



C	081-001GSHA/227	
E	M2.5-S8/S8	
S	~937x39 (11 SEG/ROW)	
M	4 ROWS	35%

11 759

09

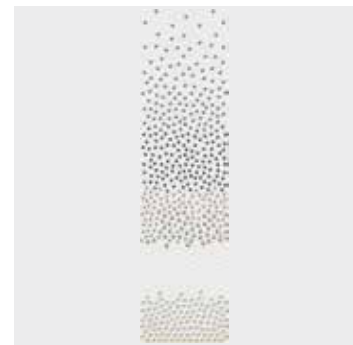

C	001SINI/280HEM/001SSHA/001MOL/ 234/001SSHA/234/001MOL	
E	S6/S6/S6/S8/S8/S8/S10/S10	
S	~51x192	
M	16 PCS	23%

11 762

07

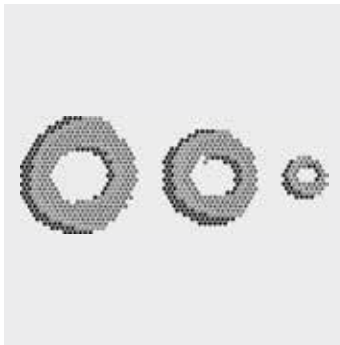

C	001SINI/280/280HEM/001MOL	
E	S8/S8/S8/S8	
S	~177x68	
M	12 PCS	23%

11 770

06



C	246/001GSHA/391	
E	S6/S6/S6	
S	~73x129	
M	21 PCS	33%

11 786

05



C	213SAT/550/001MLGLD/001GSHA	
E	S6/S6/S6/S6	
S	~124x170	
M	10 PCS	25%

11 833

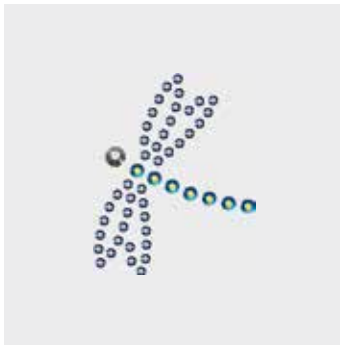

C	001METBL/280AB/280HEM	
E	PP7/S6/S10	
S	~21x27	
M	72 PCS	100%

11 837

03



C	092-001	
E	M2-S6	
S	~17x17	
M	296 PCS	100%

11 870

12



C	001SSHA/280HEM	
E	S6/S6	
S	~977x6 (63 SEG/ROW)	
M	14 ROWS	90%

11 871

04



C	246/001GSHA	
E	PP7/S6	
S	~30x29	
M	45 PCS	100%

11 873

04

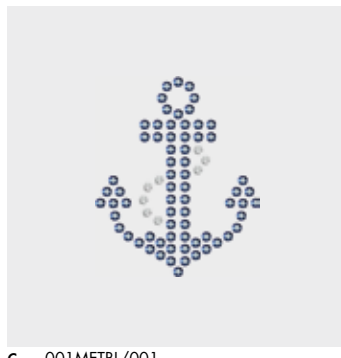

C	001METBL/001	
E	PP7/PP7	
S	~22x26	
M	40 PCS	100%

11 881

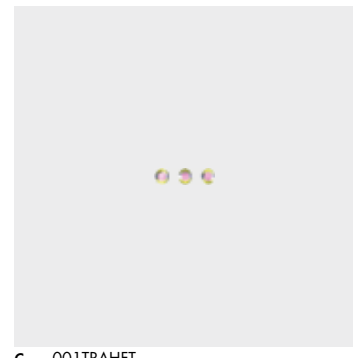

C	001TRAHFT	
E	S6	
S	~986x2 (329 SEG/ROW)	
M	18 ROWS	100%

11 899 11

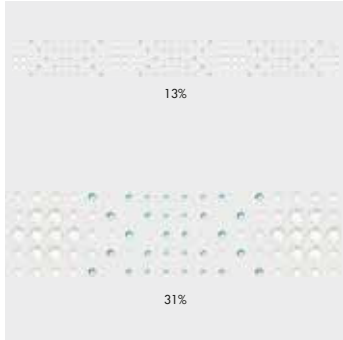

C 202/202/001MOL/202/001MOL/
001MOL/001MOL/001MOL
E S6/S8/S10/S12/S16/S20/S34
S ~331x36
M 8 PCS

11 904



C 082/092-234/001/001TRAHFT
E M2/M2-S6/S6/S6
S ~119x120
M 7 PCS 35%

11 905 03



C 001AB
E PP7
S ~15x17
M 66 PCS 100%

11 911 02



C 092-001MOL/001SSHA/001SINI/280HEM
E M2-S6/S6/S6/S6
S ~139x46
M 24 PCS 30%

11 956



C 001SSHA/391/001AB
E PP7/S6/S10
S ~48x105
M 10 PCS 40%

11 982 11

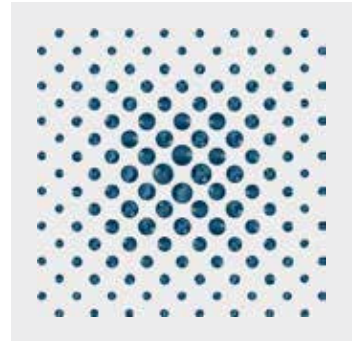

C 266/266/266/266/266/266
E S6/S8/S10/S12/S16/S20
S ~64x64
M 39 PCS 60%

11 983 03



C 502/501
E S6/S10
S ~48x29
M 108 PCS 80%

11 984

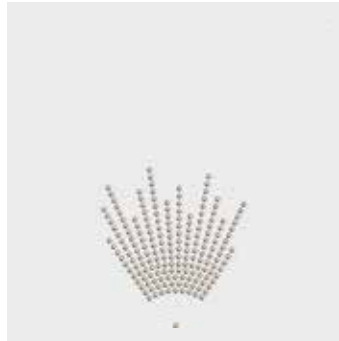

C 001MOL/001SSHA
E S6/S8
S ~139x137
M 6 PCS 30%

11 988 03



C 001AB/001
E S6/S8
S ~37x34
M 105 PCS 100%

12 007



C 234/280HEM/001SSHA/001COS/
383/001AB/001MOL
E S6/S6/S6/S6/S6/S6/S6
S ~76x76
M 22 PCS 55%

12 011 04



C 001AB/001AB/277/283/539/283/
001AB
E CS8x5/S6/S6/S6/S8/S8/S10
S ~49x38
M 68 PCS 85%

12 023 03



C 001AB/289/223/502/001AB/209/
001AB
E S6/S6/S6/S8/S8/S8/S10
S ~209x41
M 19 PCS 20%

Transfers

Standard Collection

12 034 06



C 001DOR/001GSHA/001MLGLD/220/
220SAT/280NUT
E S6/S6/S6/S6/S6/S6
S ~48x143
M 18 PCS 28%

12 051 10

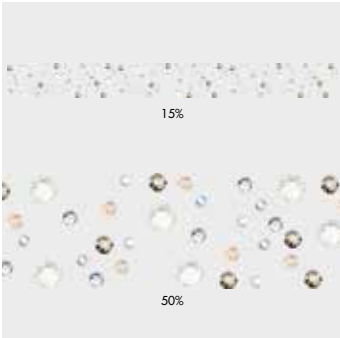

C 001 650/001AB/391/001/001SSHA/
001MOL
E P3/S12/S16/S16/S20/S34
S ~977x30 (10 SEG/ROW)
M 4 ROWS

12 070



C 001MOL/234/001AB/001TRAHFT
E S6/S6/S6/S6
S ~24x24
M 174 PCS 100%

12 111 02



C 319/280HEM/001SINI/391/001ANTP
E S6/S6/S6/S8/S8
S ~210x63
M 13 PCS 20%

12 048 05



C 001 650/001 650/001AB/214/291/
205/294/001AB
E P3/P4/CS8x4/S6/S8/S10/S10/S10
S ~52x54
M 45 PCS 70%

12 055 06



C 246/001MLGLD/001GSHA
E PP7/S6/S10
S ~73x73
M 6 PCS 55%

12 084 11

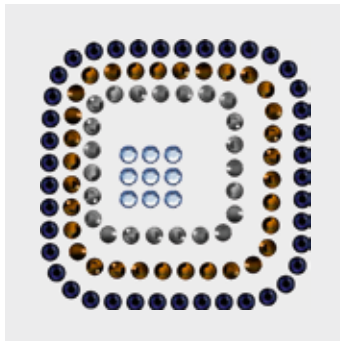

C 288/001BRSH/001SINI/211
E S8/S8/S8/S8
S ~36x36
M 84 PCS 100%

12 116 06



C 001GSHA/001COP/001MLGLD/
001BRSH/001GSHA/220/391
E CS8x4/CS3x3/S6/S8/S10/S10/S12
S ~266x56
M 9 PCS 16%

12 050 07



C 280HEM/280HEM/280/280HEM/284/
001SSHA/001SINI
E CS8x5/CS8x4/CS5x3/S6/S8/S10/S10
S ~82x82
M 20 PCS 45%

12 056 07



C 001MOL/001SSHA/001SINI/383
E S6/S8/S10/S12
S ~61x61
M 42 PCS 65%

12 093 12

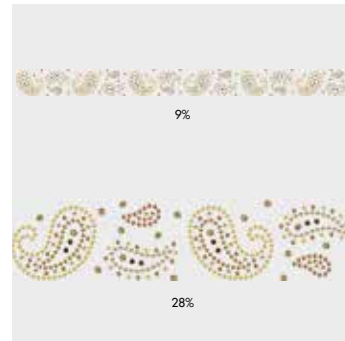

C 091/081-001GSHA/001COP/
001BRSH/001MLGLD
E M2/M2-S6/S6/S8/S12
S ~981x38 (6 SEG/ROW)
M 4 ROWS

12 125 07



C 001MOL/001SSHA/284/001SINI/
001SINI/280HEM/001SSHA/284/001
E S6/S8/S10/S12/S16/S20/S34/S34/S40
S ~103x102
M 16 PCS 45%

12 134

02



C	001AB
E	S5
S	~288x38
M	12 PCS
	15%

12 929

Innovation Box



C	653/215/001SINI/657/001
E	S10/S10/S10/S10/S10
S	~41x23
M	116 PCS
	90%

12 967

Innovation Box

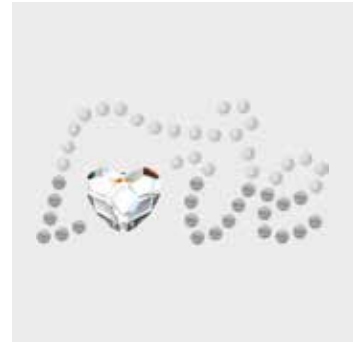

C	092/082-001
E	M2/M2-2808MM100
S	~39x19
M	147 PCS
	100%

18 117



C	092/092-001 191/213SAT/001SSHA/001MOL
E	M2/M2-P4/S6/S10/S16
S	~91x139
M	14 PCS
	30%

18 319

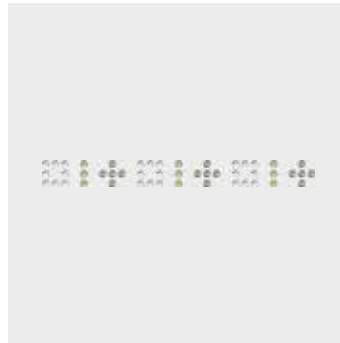

C	001/215/390
E	S6/S6/S6
S	~972x7 (39 SEG/ROW)
M	13 ROWS
	50%

18 320

03

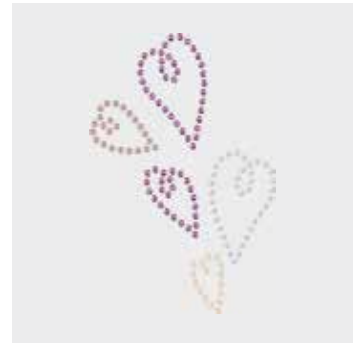

C	092-001ANTP/319/391
E	M2-S6/S6/S6
S	~55x82
M	44 PCS
	45%

18 326

02



C	001SSHA/001SINI/001SSHA
E	S6/S8/S12
S	~172x52
M	16 PCS
	25%

18 335



C	227/001TRAHFT/220/228
E	S6/S6/S6/S6
S	~39x43
M	80 PCS
	80%

18 559

04



C	246/001GSHA
E	PP7/S6
S	~19x45
M	40 PCS
	90%

18 560

04



C	001 291/229/280AB/001AB/001COS
E	P3/S6/S6/S6/S8
S	~49x50
M	64 PCS
	80%

18 563

04



C	291/001AB/205/001COS
E	S6/S6/S8/S8
S	~28x23
M	174 PCS
	100%

18 571



C	223/213AB/236/249
E	S6/S6/S6/S6
S	~37x38
M	84 PCS
	100%

Transfers

Standard Collection

18 585



C	001/234/001GSHA/001
E	S6/S8/S10/S12
S	~60x60
M	42 PCS 60%

18 615



C	319/001TRAHFT
E	S6/S6
S	~65x65
M	45 PCS 60%

18 913

Innovation Box



C	280HEM/001SINI/001SSH
E	2817MM5/S6/S8
S	~63x20
M	99 PCS 65%

18 926

Innovation Box



C	082-001
E	M2-2855MM8
S	~45x11
M	172 PCS 90%

726 198



C	091/081-001 291/213SAT/001DOR/001
E	M2/M2-P4/S6/S10/S10
S	~913x130 (12 SEG/ROW)
M	1 ROW 18%

Transfers

Standard Collection



10 484 **14**



C	001SSHA
E	S10
S	~478x213
M	2 PCS
	100%

10 487 **15**

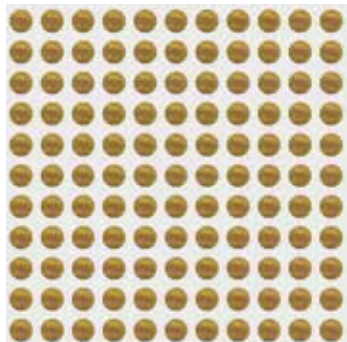

C	081
E	M3
S	~485x218
M	2 PCS
	95%

10 490 **14**



C	280HEM
E	S34
S	~477x207
M	2 PCS
	90%

10 482 **14**

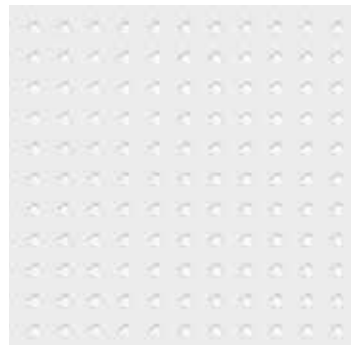

C	001MOL
E	S6
S	~478x214
M	2 PCS
	100%

10 485 **15**

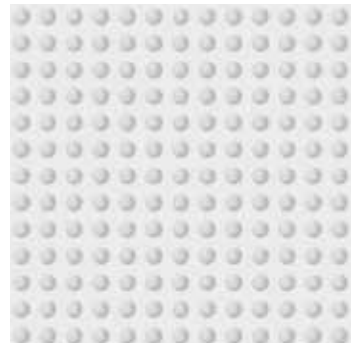

C	092
E	M2.5
S	~486x216
M	2 PCS
	100%

10 488 **14**

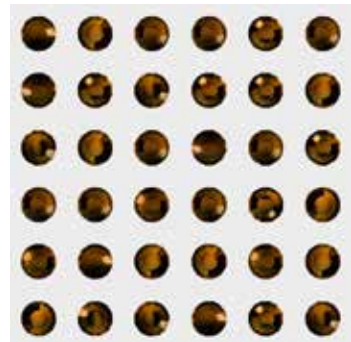

C	001BRSH
E	S20
S	~478x208
M	2 PCS
	100%

10 491 **15**

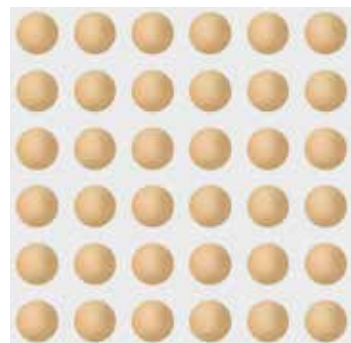

C	094
E	M6
S	~486x214
M	2 PCS
	95%

10 483 **15**



C	091
E	M2
S	~485x218
M	2 PCS
	100%

10 486 **14**



C	001SINI
E	S16
S	~479x212
M	2 PCS
	100%

10 489 **15**

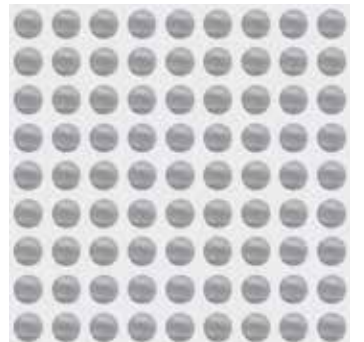

C	082
E	M4
S	~485x218
M	2 PCS
	100%

10 492 **15**

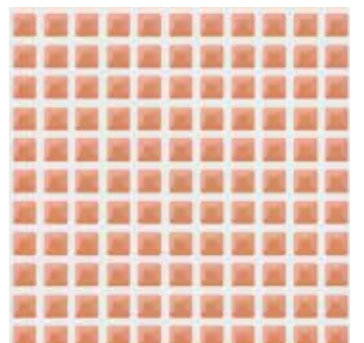

C	086
E	M3x3
S	~486x217
M	2 PCS
	98%

Transfers

Standard Collection

10 493 **15**

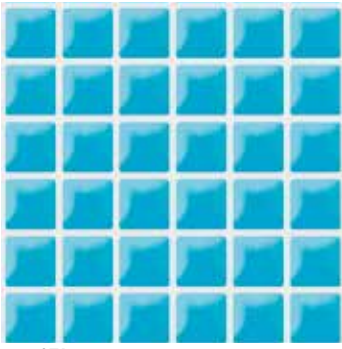

C 071	
E M7x7	
S ~486x215	
M 2 PCS	94%

10 494 **15**

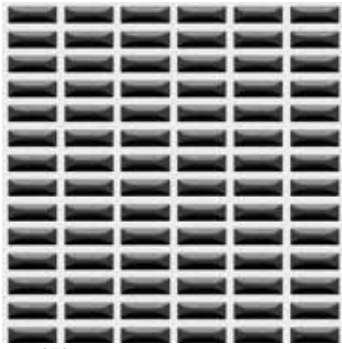

C 070	
E M7x3	
S ~486x216	
M 2 PCS	93%

10 496 **15**

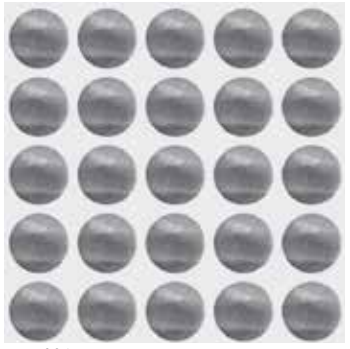

C 086	
E M8	
S ~486x216	
M 2 PCS	100%

11 368 **14**

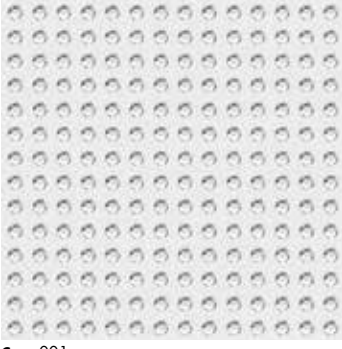

C 001	
E S6	
S ~476x216	
M 2 PCS	100%

11 369 **14**

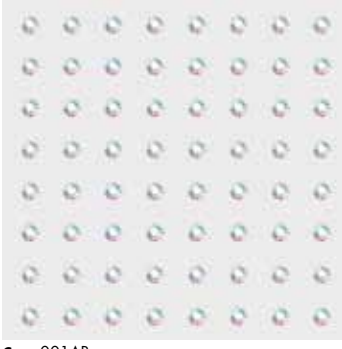

C 001AB	
E S8	
S ~475x217	
M 2 PCS	100%

11 461 **14**



C 001GSHA	
E S10	
S ~478x210	
M 2 PCS	100%

CRYSTAL INSPIRATIONS COLLECTIONS

Extensive trend research allows Swarovski to present its own Crystal Inspirations Collections twice a year. These collections reflect the trends of the coming fashion seasons (Spring/Summer and Fall/Winter) and include new and innovative design ideas, shapes, and colors in tune with those trends.



12 160 S/S 2007 11



C	280HEM/280HEM/001COS/209COS
E	CS3x3/S6/S8/S10
S	~111x13
M	72 PCS
	38%

12 162 S/S 2007 11

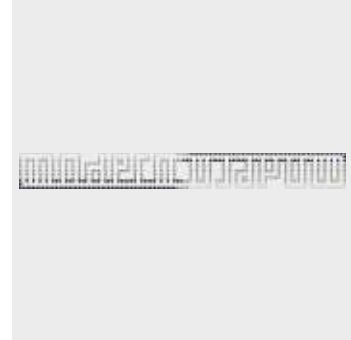

C	280/215/280HEM/001
E	S6/S6/S6/S6
S	~240x26
M	18 PCS
	18%

12 197 S/S 2007 19



C	209/280HEM/542/226/001COS/ 001SSHA/362/360/213AB
E	S5/S5/S6/S6/S6/S6/S6/S8
S	~187x101
M	10 PCS
	23%

12 204 S/S 2007 20



C	001COS/001SSHA/362/001GSHA/ 001GSHA/001SSHA/001COS/362
E	S6/S6/S6/S6/S8/S8/S8/S8
S	~160x160
M	8 PCS
	25%

12 206 F/W 2007/08 07

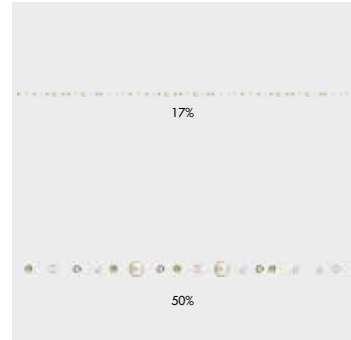

C	001 291/001AB/001GSHA/213SAT/391
E	P4/S5/S6/S6/S8
S	~953x4 (11 SEG/ROW)
M	12 ROWS

12 223 F/W 2007/08 20



C	280HEM/280HEM/515/280AB/ 001SSHA/209COS
E	P3/CS5x3/S8/S8/S12/S16
S	~34x44
M	90 PCS
	100%

12 262 F/W 2007/08 11



C	215/001SSHA/001AB/280HEM
E	S6/S8/S8/S8
S	~206x81
M	10 PCS
	20%

12 265 F/W 2007/08 11

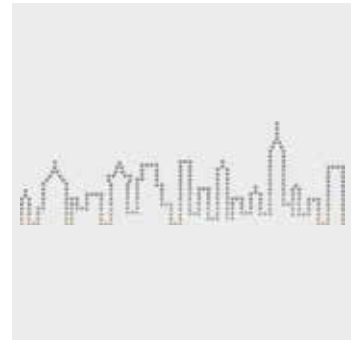

C	280HEM/215/001SSHA
E	S6/S6/S6
S	~171x55
M	15 PCS
	25%

12 276 F/W 2007/08 17

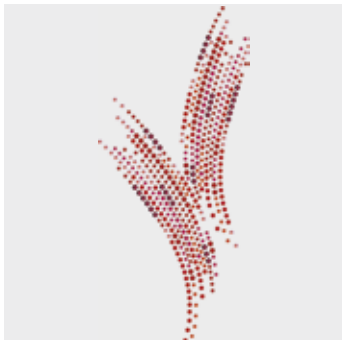

C	208/501/227AB/236/227/501/208/ 227SAT
E	S6/S6/S6/S6/S8/S8/S10/S10
S	~80x177
M	12 PCS
	25%

12 305 S/S 2008 08



C	001AB/001
E	S5/S5
S	~108x111
M	16 PCS
	35%

12 329 S/S 2008 10



C	001/001SSHA
E	PP7/PP7
S	~22x36
M	28 PCS
	100%

12 333 S/S 2008 **12**



C 001/001SSHA
 E CS5x2/S16
 S ~981x15 (117 SEG/ROW)
 M 7 ROWS 100%

12 361 F/W 2008/09 **08**

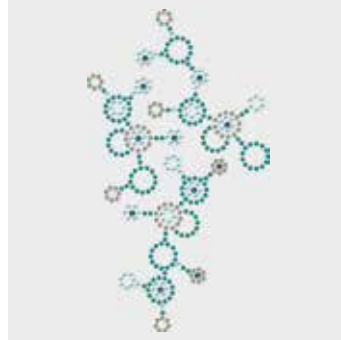

C 229/215/202/207
 E S5/S5/S6/S8
 S ~75x133
 M 18 PCS 32%

12 389 F/W 2008/09 **14**



C 550/229SAT/228/238/360/383/280NUT
 E S6/S6/S6/S6/S6/S6/S8
 S ~106x101
 M 16 PCS 35%

12 416 F/W 2008/09 **10**



C 215/280HEM/001SSHA/001/284/383
 E S5/S5/S6/S6/S8/S8
 S ~91x55
 M 30 PCS 45%

12 476 S/S 2009 **11**



C 001COP/286/001GSHA/220/213SAT/
 515/001MLGD
 E S6/S6/S8/S8/S8/S8/S8
 S ~88x160
 M 12 PCS 25%

12 508 F/W 2009/10 **05**

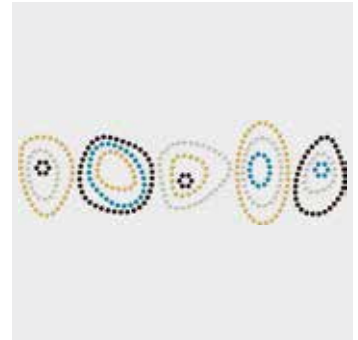

C 091-234/286/394
 E M2-S6/S6/S6
 S ~131x42
 M 28 PCS 33%

12 519 F/W 2009/10 **09**



C 223/209/286/001COP/220/204/
 001BRSH/001ANTP
 E S5/S5/S6/S6/S8/S8/S10/S12
 S ~68x69
 M 24 PCS 55%

12 541 F/W 2009/10 **13**



C 280/280HEM/288/288
 E S5/S6/S10/S12
 S ~81x91
 M 20 PCS 45%

12 566 S/S 2010 **05/09**

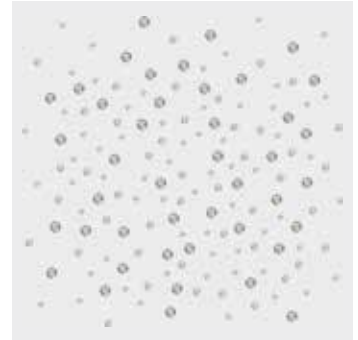

C 001/001/001SSHA
 E PP7/PP12/PP17
 S ~71x68
 M 3 PCS 60%

12 567 S/S 2010 **05**



C 001SSHA/001/391
 E PP7/PP12/S6
 S ~204x82
 M 2 PCS 40%

12 570 S/S 2010 **10**



C 001/001AB/001
 E S6/S8/S10
 S ~920x62 (10 SEG/ROW)
 M 3 ROWS 40%

12 577 S/S 2010 **11**

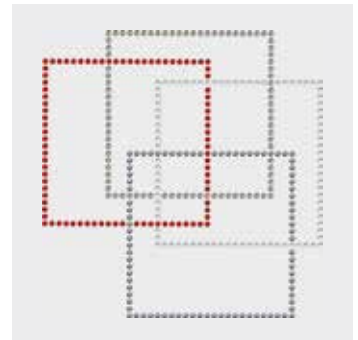

C 227/280HEM/215/001
 E S5/S5/S5/S5
 S ~92x95
 M 18 PCS 40%

12 580 S/S 2010 **11**



C 001/215/280HEM/280
E S5/S5/S5/S6
S ~105x123
M 14 PCS **35%**

12 584 S/S 2010 **13**

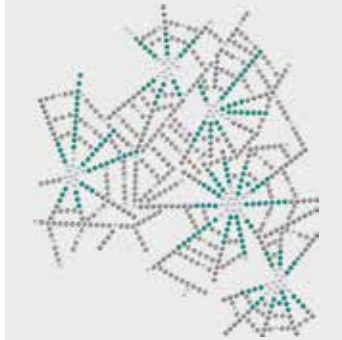

C 215/229/280HEM/001
E S5/S5/S5/S5
S ~108x125
M 8 PCS **35%**

12 585 S/S 2010 **13**

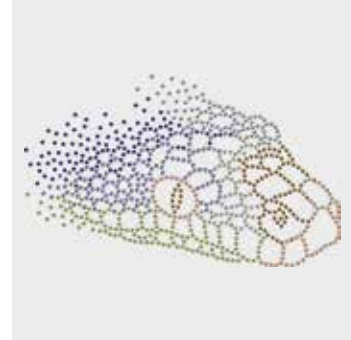

C 280HEM/215/206SAT/550/277/
001DOR/220SAT
E S5/S5/S6/S6/S6/S6
S ~150x91
M 12 PCS **28%**

12 586 S/S 2010 **13**



C 215/001SSHA/206SAT/277
E S5/S6/S8/S10
S ~65x36
M 66 PCS **60%**

12 588 S/S 2010 **13**



C 280HEM/220/206SAT/277/550/
215/220SAT
E S5/S6/S6/S6/S8/S8/S10
S ~88x137
M 12 PCS **30%**

12 605 F/W 2010/11 **09/06**

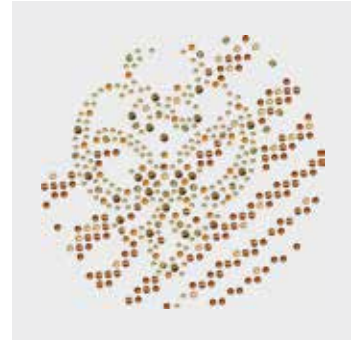

C 001GSHA/220/203/001COP/246/
001MLGLD/001DOR
E S6/S8/S8/S10/S10/S10/S12
S ~107x103
M 16 PCS **35%**

12 606 F/W 2010/11 **09**



C 213AB/539/226/228/289/203/501/
550/542
E S6/S6/S6/S6/S8/S8/S10/S10
S ~75x160
M 12 PCS **25%**

12 614 F/W 2010/11 **09**



C 096/086-229SAT/228/001DOR/
001MLGLD/550
E M2/M2-S6/S6/S6/S6
S ~57x134
M 21 PCS **30%**

12 615 F/W 2010/11 **09**



C 096-001 191/001 191/001/550/
001MLGLD/228/284
E M2-P3/P4/CS8x5/S6/S6/S6/S10
S ~130x97
M 12 PCS **30%**

12 616 F/W 2010/11 **13**

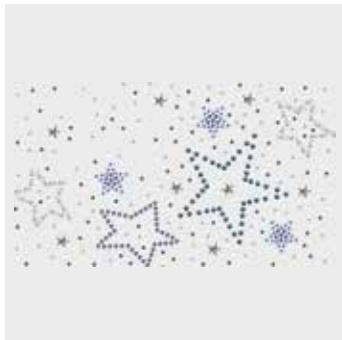

C 096/062-001/001MOL/001COS/206/
206SAT/001METBL
E M2/MST-CS5x2/S6/S6/S6/S8/S10
S ~193x111
M 8 PCS **22%**

12 620 F/W 2010/11 **13**

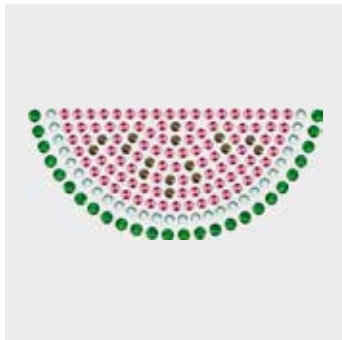

C 289/238/280NUT/291
E S6/S6/S6/S8
S ~56x25
M 90 PCS **70%**

12 630 F/W 2010/11 **07**

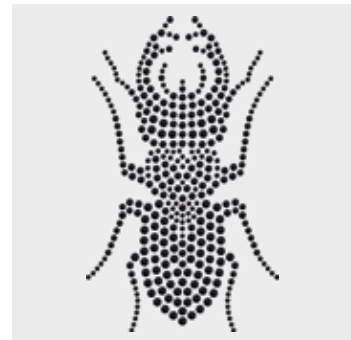

C 280/280/280/280/280
E S5/S6/S8/S10/S12
S ~73x119
M 14 PCS **35%**

12 634 F/W 2010/11 07



C 096-215/280HEM/001/215
 E M10-S3/S5/S5/S5
 S ~80x75
 M 12 PCS 50%

12 635 F/W 2010/11 07



C 284/550/220/215/001TAB/001COP/
 001MLGLD/001GSHA
 E S6/S6/S6/S6/S6/S6/S6/S6
 S ~158x93
 M 12 PCS 25%

12 636 F/W 2010/11 07

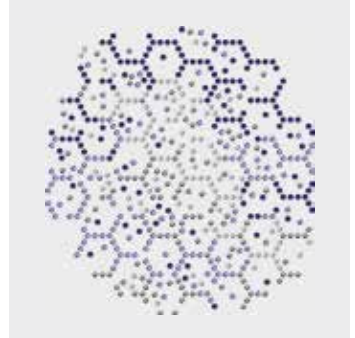

C 096-280HEM/277/539
 E M2-S5/S6/S6
 S ~89x95
 M 20 PCS 40%

12 639 F/W 2010/11 05/12

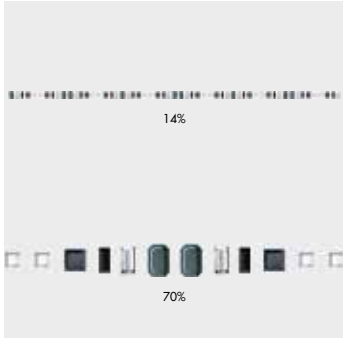

C 280HEM/280/001/001/280HEM
 E CS6x4/CS5x2/CS5x2.5/CS3x3/CS4x4
 S ~937x6 [9 SEG/ROW]
 M 11 ROWS

12 650 F/W 2010/11 11/04



C 001AB/211/266/280HEM
 E S5/S6/S6/S10
 S ~117x151
 M 7 PCS 28%

12 651 F/W 2010/11 11/09



C 001SINI/284/215/280HEM/001MOL/
 001SSHA/001
 E S6/S6/S6/S6/S6/S8/S10
 S ~98x196
 M 9 PCS 20%

12 653 F/W 2010/11 11/10

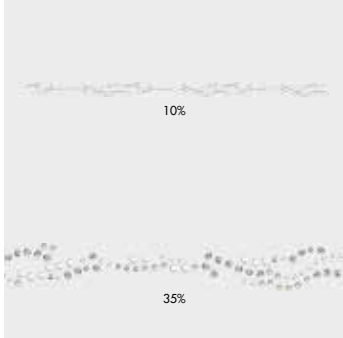

C 001 650/001MOL/001AB/001SSHA/
 234/284
 E P3/S6/S6/S6/S8/S10
 S ~932x18 [7 SEG/ROW]
 M 8 ROWS

12 661 S/S 2011 11

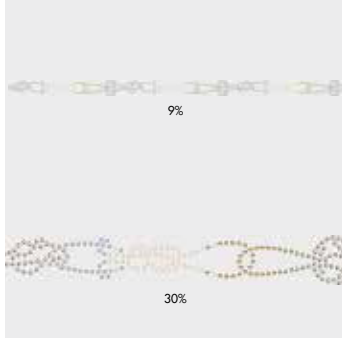

C 096-001SSHA/391/001GSHA
 E M2-S6/S6/S6
 S ~981x22 [6 SEG/ROW]
 M 7 ROWS

12 667 S/S 2011 11/04



C 001GSHA
 E S6
 S ~66x146
 M 18 PCS 28%

12 668 S/S 2011 11/04



C 001/246/243/391
 E S5/S5/S5/S6
 S ~66x84
 M 30 PCS 50%

12 672 S/S 2011 09/06



C 246/001MLGLD/001BRSH/280NUT/
 246/220/001BRSH/001GSHA/220SAT
 E S5/S6/S6/S6/S6/S8/S10/S12/S20
 S ~103x128
 M 14 PCS 33%

12 679 S/S 2011 09/04



C 001AB/280/229/280AB/229/280HEM
 E S3/S3/S5/S8/S10/S10
 S ~60x51
 M 28 PCS 60%

12 680 S/S 2011 09/04

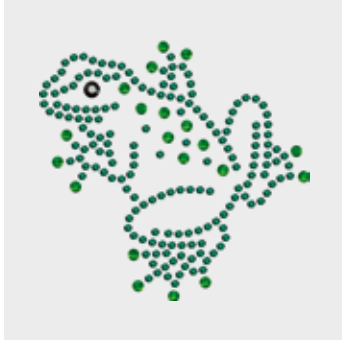

C 205/291/001COS
E PP7/S6/S10
S ~45x43
M 22 PCS 80%

12 681 S/S 2011 05/05



C 001AB/291/229SAT/214
E S5/S6/S6/S6
S ~62x157
M 18 PCS 26%

12 683 S/S 2011 05/04

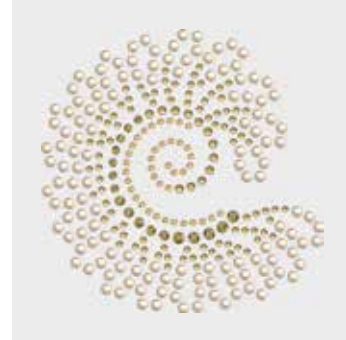

C 001 295/246/001GSHA/001GSHA/
001MLGLD/001MLGLD/001MLGLD
E P3/S5/S6/S8/S8/S10/S12
S ~75x75
M 24 PCS 50%

12 684 S/S 2011 05/05



C 001AB/229SAT/001MOL/001AB
E CS8X5/S6/S6/S8
S ~76x129
M 14 PCS 33%

12 689 S/S 2011 05/10



C 001 650/001AB/001/001MOL/234/
001SINI/001TRAHFT/001SSHA/001TRAHFT
E P3/CS8X5/CE8X4/S6/S6/S6/S6/S6/S12
S ~274x83
M 6 PCS 16%

12 700 S/S 2011 13/11

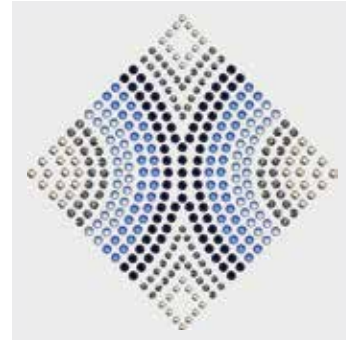

C 001SINI/001SSHA/288/206/211/
001SINI/001SSHA
E S6/S6/S8/S8/S8/S8/S8
S ~82x83
M 42 PCS 50%

12 707 S/S 2011 07/03



C 001/223/001AB/209/001AB/001/
001ANTP/391
E S3/S3/S5/S5/S6/S6/S6/S8
S ~80x76
M 12 PCS 50%

12 710 S/S 2011 07/03



C 001AB/502
E S3/S6
S ~81x64
M 18 PCS 50%

12 716 S/S 2011 07/02

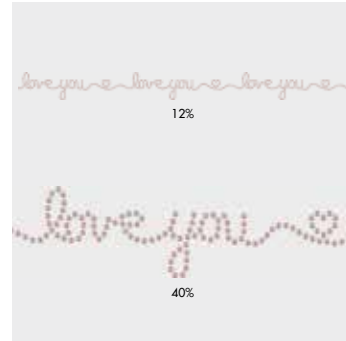

C 319
E S6
S ~966x30 (8 SEG/ROW)
M 5 ROWS

12 721 F/W 2011/12 06



C 234/391/001MOL/001AB
E S6/S6/S6/S6
S ~102x73
M 24 PCS 40%

12 722 F/W 2011/12 06/03



C 001/001AB/234/001AB
E S3/S5/S6/S8
S ~31x27
M 90 PCS 100%

12 727 F/W 2011/12 08

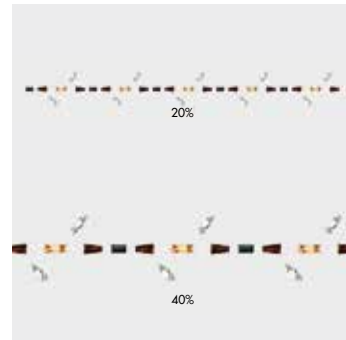

C 280HEM/001/001GSHA/220
E CS5x2.5/2797MM8x4/2555MM8x2.6/
2770MM60x35
S ~207x22
M 27 PCS

12 733 F/W 2011/12 08



C 215/246/001COP/220
E S5/S5/S6/S8
S ~112x74
M 24 PCS 37%

12 740 F/W 2011/12 14

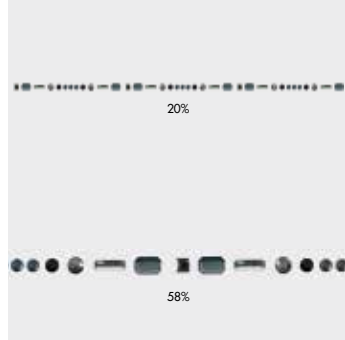

C 096/096-280HEM/280HEM/280/001SINI
E M3X3/M7X3-P3/CS6X4/S12/S16
S ~956x4 (13 SEG/ROW)
M 12 ROWS

12 741 F/W 2011/12 14

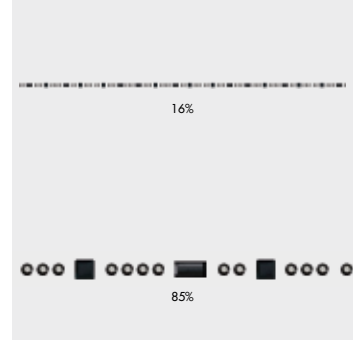

C 280HEM/280/001COS
E CS5X2.5/CS3X3/S6
S ~899x3 (10 SEG/ROW)
M 14 ROWS

12 744 F/W 2011/12 14



C 280HEM/001SINI/001COS
E CS5X2.5/S6/S16
S ~56x62
M 45 PCS 65%

12 747 F/W 2011/12 11

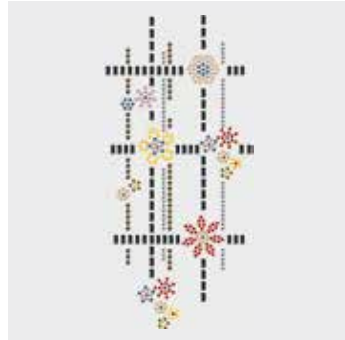

C 280HEM/227/280HEM/246/209/292/
207/001DOR/280NUT
E CS5X2/S5/S5/S5/S6/S6/S6/S8
S ~76x165
M 11 PCS 25%

12 748 F/W 2011/12 11

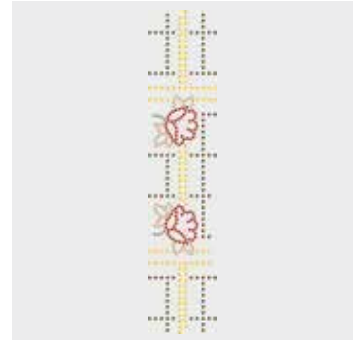

C 223/227/246/215/280NUT/292
E S3/S5/S5/S5/S6/S6
S ~43x204
M 10 PCS 21%

12 751 F/W 2011/12 11



C 246/215/246/227/288/208/
227SAT/550
E S3/S5/S5/S5/S6/S6/S6/S6
S ~97x117
M 8 PCS 35%

12 758 F/W 2011/12 12



C 327/246/229/246/001AB/215/226/
550/001COS
E S3/S3/S5/S5/S5/S5/S6/S6/S12
S ~105x57
M 16 PCS 40%

12 763 F/W 2011/12 12

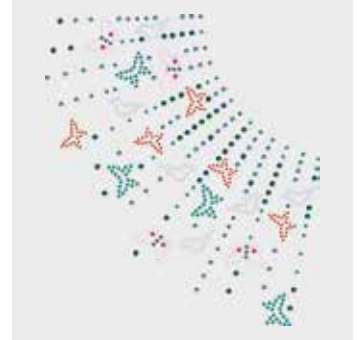

C 280HEM/327/223/001AB/229/
001METBL/280AB/502/229SAT
E P3/S3/S3/S5/S6/S6/S8/S8/S10
S ~145x165
M 4 PCS 25%

12 764 F/W 2011/12 12/04



C 280/001/229/246/280/001COP/
280/001COS
E S3/S3/S5/S5/S5/S6/S6/S8
S ~60x57
M 32 PCS 70%

12 766 S/S 2012 06



C 327/502/308/501
E S3/S6/S6/S6
S ~155x101
M 6 PCS 27%

12 769 S/S 2012 06/12

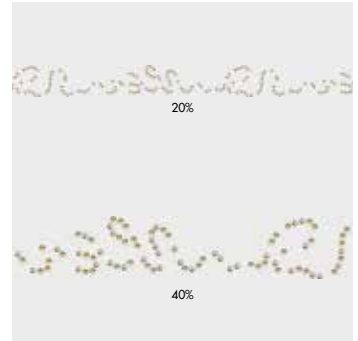

C 001GSHA/001SSHA/001MOL
E S6/S6/S6
S ~976x21 (7 SEG/ROW)
M 7 ROWS

12 770 S/S 2012 **06/09**



C 001/215/280HEM/001/001MOL/
001SSHA/001SINI/280
E S3/S5/S5/S5/S6/S6/S6/S6
S ~62x134
M 10 PCS **32%**

12 771 S/S 2012 **06/06**



C 001GSHA/001BRSH/001COP/001MLGLD/
280NUT/001GSHA/001DOR/220
E CS8X5/S6/S6/S6/S6/S8/S8/S10
S ~50x196
M 16 PCS **22%**

12 772 S/S 2012 **06/09**



C 001SSHA/001MOL/001
E S6/S6/S6
S ~96x37
M 42 PCS **45%**

12 775 S/S 2012 **08**

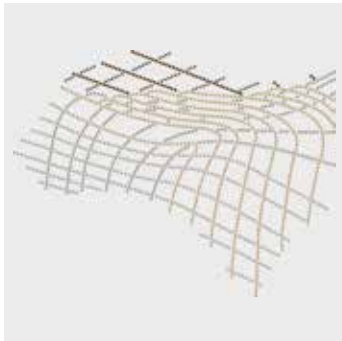

C 084-001SSHA/215/001BRSH/001SINI
E M2-S6/S6/S6/S6
S ~224x171
M 5 PCS **19%**

12 778 S/S 2012 **08/02**



C 215
E S3
S ~114x26
M 24 PCS **35%**

12 783 S/S 2012 **08/12**

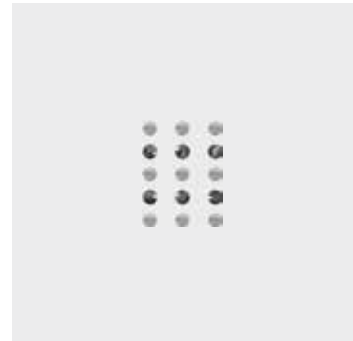

C 082-001SINI
E M2-S6
S ~984x14 (232 SEG/ROW)
M 9 ROWS **100%**

12 784 S/S 2012 **08/11**

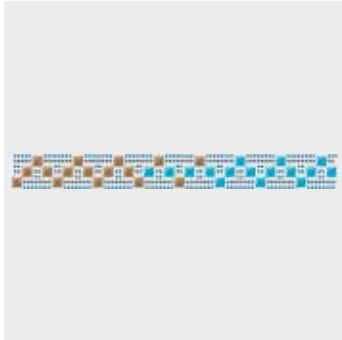

C 084/071-394/207
E M7X7/M7X7-S6/S6
S ~226x23
M 24 PCS **19%**

12 787 S/S 2012 **12**



C 091/081/091-280HEM/280HEM/
001BRSH
E M3X3/M7X3/M7X3-CS6X4/CS5X2.5/S6
S ~210x204
M 6 PCS **20%**

12 788 S/S 2012 **12/06**



C 001GSHA/246/001COP/001DOR/001DOR
E CS3X3/S5/S6/S6/S12
S ~40x40
M 76 PCS **100%**

12 789 S/S 2012 **12/02**



C 001GSHA/001BRSH/001DOR
E 2555MM8X2.6/S6/S6
S ~57x83
M 30 PCS **50%**

12 790 S/S 2012 **12**



C 094-001GSHA/001BRSH/001MLGLD/
001DOR
E M2.5-S6/S6/S8/S12
S ~140x42
M 24 PCS **30%**

12 793 S/S 2012 **10**



C 081/094-515/308/001COP
E M2/M2-S6/S6/S6
S ~58x119
M 21 PCS **34%**

12 794 S/S 2012 **10/02**



C	246/220/246	
E	PP7/PP12/S3	
S	~106x27	
M	12 PCS	40%

12 795 S/S 2012 **10**



C	084/081-001 295/246/001GSHA/220	
E	M2/M2-P3/S5/S6/S6	
S	~208x19	
M	31 PCS	20%

12 797 S/S 2012 **10/09**



C	081-001/280HEM/215/280	
E	M2-S5/S5/S5/S6	
S	~92x180	
M	13 PCS	23%

12 802 S/S 2012 **04/05**

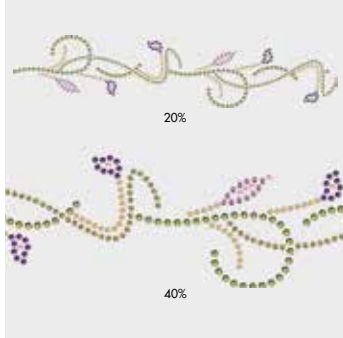

C	246/223/001MLGLD/204/001ANTP/550	
E	S5/S5/S6/S6/S6/S8	
S	~214x48	
M	19 PCS	

12 804 S/S 2012 **04**



C	229/246/550/291/001TAB	
E	S5/S5/S6/S6/S6	
S	~190x69	
M	12 PCS	22%

12 805 S/S 2012 **04/05**



C	001AB/291/214/205	
E	CS8X4/S6/S10/S16	
S	~57x54	
M	45 PCS	70%

12 806 S/S 2012 **04/05**



C	223/212/204/001ANTP/223	
E	S3/S6/S8/S10/S16	
S	~79x59	
M	18 PCS	50%

12 807 S/S 2012 **04**

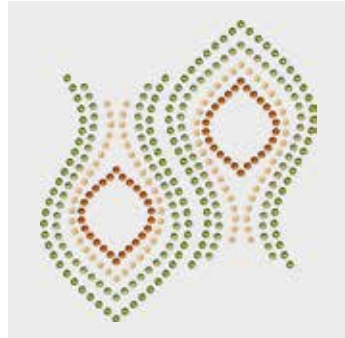

C	094-228/550/220	
E	M2-S6/S6/S6	
S	~73x80	
M	24 PCS	50%

12 809 S/S 2012 **04**



C	209/227/542	
E	S5/S6/S6	
S	~37x77	
M	55 PCS	50%

12 810 F/W 2012/13 **04**

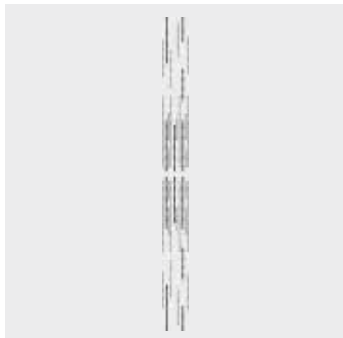

C	215/280/280HEM	
E	S5/S5/S5	
S	~29x343	
M	10 PCS	12%

12 811 F/W 2012/13 **04**



C	234/001SSHA/215/001/001MOL/280HEM/001SINI/280	
E	S6/S6/S6/S6/S6/S6/S6/S6	
S	~58x165	
M	15 PCS	25%

12 812 F/W 2012/13 **04**

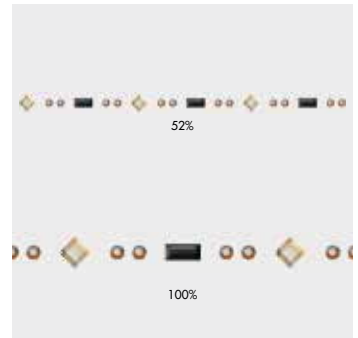

C	280HEM/001GSHA/220SAT	
E	CS5X2/CS3X3/S6	
S	~963x4 (34 SEG/ROW)	
M	14 ROWS	

12 813 F/W 2012/13 04

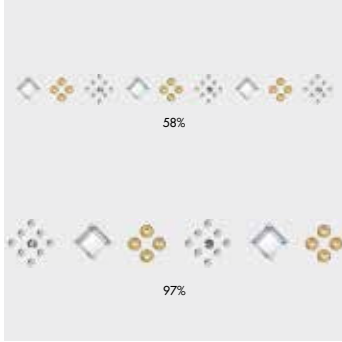

C	001/001/215/246
E	CS4x4/S3/S3/S5
S	~503x7 (21 SEG/ROW)
M	12 ROWS

12 814 F/W 2012/13 04



C	001 414/001GSHA/220/246/ 001GSHA/286	
E	P3/2770MM60x35/S3/S5/S6/S6	
S	~39x51	
M	49 PCS	77%

12 815 F/W 2012/13 04

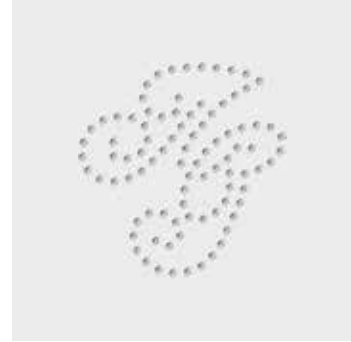

C	001	
E	S3	
S	~28x28	
M	105 PCS	100%

12 816 F/W 2012/13 04



C	280/280/280/280	
E	CS5x2,5/S3/S5/S6	
S	~80x48	
M	20 PCS	50%

12 817 F/W 2012/13 04

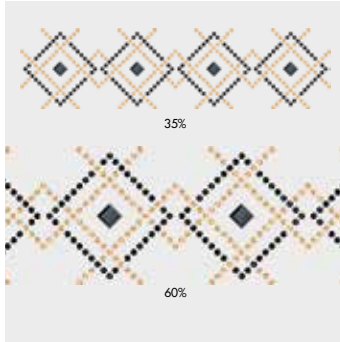

C	280HEM/246/280
E	CS4x4/S3/S3
S	~117x30
M	24 PCS

12 818 F/W 2012/13 04



C	070-215/001/280HEM/215/ 001SSHA/001COS	
E	M2-S3/S3/S5/S5/S6/S8	
S	~154x112	
M	4 PCS	27%

12 819 F/W 2012/13 06



C	096/086/070/082/071-280HEM/ 001SSHA/394	
E	M2,5/M6/M10/M3x3/M7x3-CS5x2,5/S6/S6	
S	~39x216	
M	19 PCS	20%

12 820 F/W 2012/13 06

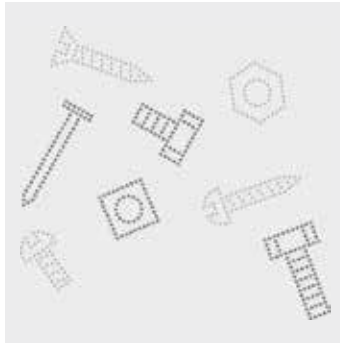

C	215/001	
E	S3/S3	
S	~117x111	
M	8 PCS	35%

12 821 F/W 2012/13 06



C	070/070-280HEM/280/001TAB/ 001MLGLD	
E	M3x3/M12x6-CS6x4/CS7x6/S10/S16	
S	~125x128	
M	7 PCS	32%

12 822 F/W 2012/13 06

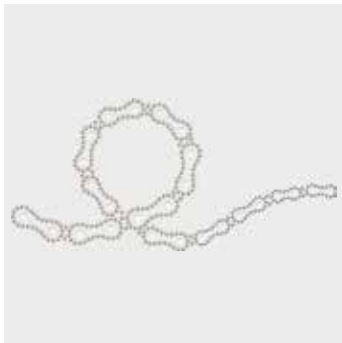

C	215/001SSHA/001SSHA/001MOL/ 001MOL/001MOL/001MOL	
E	S3/S6/S6/S8/S12/S16/S20	
S	~159x74	
M	6 PCS	27%

12 823 F/W 2012/13 06



C	280/215/215/001/266	
E	S3/S3/S5/S5/S6	
S	~60x64	
M	21 PCS	60%

12 824 F/W 2012/13 06



C	246/215/001/215/001SINI	
E	S5/S5/S5/S6/S8	
S	~130x83	
M	14 PCS	30%

12 825 F/W 2012/13 06



C 070/071-280HEM/280HEM
E M3X3/M3X3-CS5X2/CS3X3
S ~974x29 (48 SEG/ROW)
M 5 ROWS 66%

12 826 F/W 2012/13 06

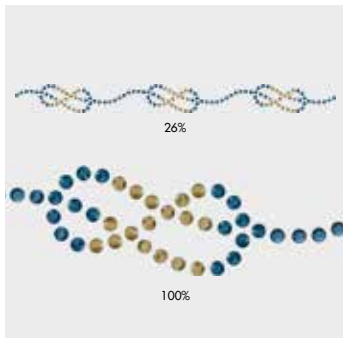

C 266/001MLGLD/207
E S6/S6/S6
S ~977x15 (18 SEG/ROW)
M 9 ROWS 100%

12 828 F/W 2012/13 12



C 071-266/327/001ANTP/243/369
E M2-S6/S6/S8/S10/S12
S ~126x86
M 14 PCS 32%

12 829 F/W 2012/13 12



C 084/071/091/094-001ANTP/243/502/501
E M2/M2/M2.5/M9X4-S6/S6/S6/S8
S ~138x197
M 6 PCS 21%

12 830 F/W 2012/13 12



C 001AB/001GSHA/001AB/327/266/
001GSHA/266/001GSHA
E CS8X5/CS8X5/CS5X2/S20/S20/S20/S34/S34
S ~96x132
M 14 PCS 30%

12 831 F/W 2012/13 12

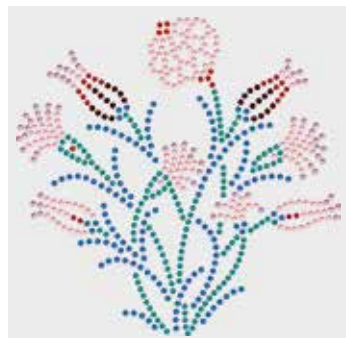

C 223/229/209/227/243/308/223
E S5/S5/S5/S5/S6/S6/S6
S ~107x105
M 18 PCS 40%

12 832 F/W 2012/13 12



C 094-280/207/288/208
E M2-2035MM10/S6/S6/S8
S ~30x88
M 48 PCS 45%

12 833 F/W 2012/13 12



C 071/070-280HEM/229/243/001METBL
E M2/M2.5-CS8X4/S5/S6/S8
S ~71x100
M 24 PCS 40%

12 835 F/W 2012/13 12

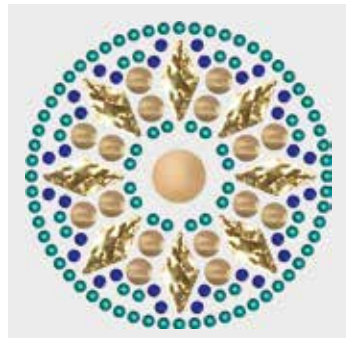

C 084/094/061-229/369
E M4/M8/M12X6-S5/S6
S ~45x45
M 68 PCS 90%

12 836 F/W 2012/13 08



C 094/070-001GSHA/001GSHA/280NUT
E M2/M2.5-CS3X3/S6/S8
S ~204x196
M 5 PCS 20%

12 837 F/W 2012/13 08



C 070-001GSHA/280HEM/001SSHA/220/
280NUT/286/220SAT
E M2-CS8X4/CS8X4/CS8X4/S6/S6/S6/S8
S ~193x129
M 7 PCS 20%

12 838 F/W 2012/13 08



C 246/220
E S3/S3
S ~32x32
M 65 PCS 100%

12 839 F/W 2012/13 **08**

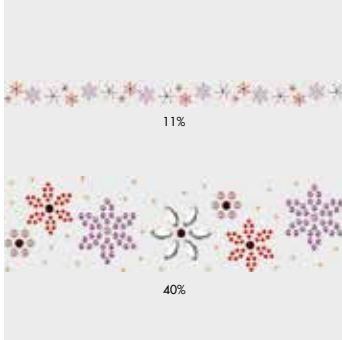

C 001SSHA/327/246/001ANTP/319/308
 E CS8X4/S3/S3/S6/S10/S10
 S ~409x32 (3 SEG/ROW)
 M 5 ROWS

12 840 F/W 2012/13 **08**



C 246/001MLGLD
 E S5/S6
 S ~114x148
 M 15 PCS **30%**

12 841 F/W 2012/13 **08**



C 001 191/001AB/319/001ANTP/223AB/
 204/391/215/001MOL
 E P3/CS8X4/S6/S6/S6/S6/S8/S8
 S ~60x150
 M 18 PCS **28%**

12 843 F/W 2012/13 **10**



C 215/327/391/236
 E S3/S3/S6/S6
 S ~151x68
 M 9 PCS **28%**

12 845 F/W 2012/13 **10**



C 094-001GSHA
 E M7X3-S10
 S ~156x22
 M 30 PCS **27%**

12 846 F/W 2012/13 **10**



C 280HEM/001AB/001AB
 E CS5X2/CS5X2,5/2035MM10
 S ~225x62
 M 12 PCS **19%**

12 847 F/W 2012/13 **10**



C 070-001METBL/001MOL/223/266/236
 E M2-S6/S6/S6/S8/S8
 S ~121x91
 M 16 PCS **35%**

12 848 F/W 2012/13 **10**

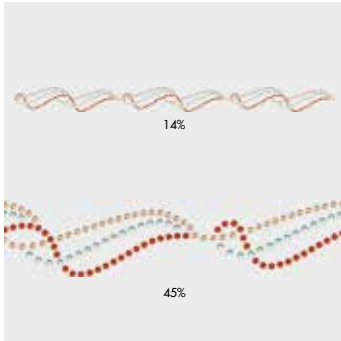

C 362/236/238
 E S6/S6/S6
 S ~910x23 (9 SEG/ROW)
 M 6 ROWS

12 849 F/W 2012/13 **10**



C 094-001GSHA/266/238/001AB/236/
 001ANTP
 E M2-S6/S6/S6/S6/S6/S6
 S ~83x139
 M 18 PCS **30%**

12 850 S/S 2013 **04**

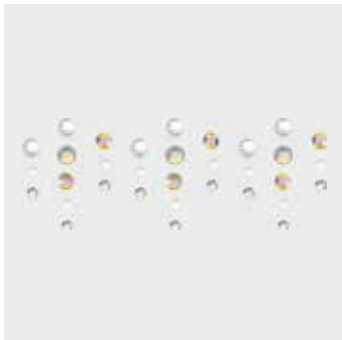

C 001 650/001/001MOL/001TRAHFT/234
 E P3/S5/S6/S10/S12
 S ~977x18 (55 SEG/ROW)
 M 7 ROWS **80%**

12 851 S/S 2013 **04**



C 092-001 191/001/001/001/001/001/001
 E M2-P3/CS8X5/CS5X2/CE8X4/S6/S8/S12
 S ~948x25 (26 SEG/ROW)
 M 6 ROWS **40%**

12 852 S/S 2013 **04**



C 001 191/001 650/001/001
 E P3/P4/2037MM8/2037MM14
 S ~41x40
 M 68 PCS **80%**

12 853 S/S 2013 **04**



C 001 650/001 191/001AB/234
E P3/P4/S5/S10
S ~59x59
M 39 PCS 70%

12 854 S/S 2013 **04**



C 001 191/ 001 191/001/001/001/001
E P3/P4/2037MM8/2037MM14/
2037MM17/S6
S ~128x193
M 7 PCS 22%

12 855 S/S 2013 **04**



C 001 650/001/001AB/234/001MOL
E P3/S3/S5/S6/S10
S ~180x96
M 4 PCS 23%

12 856 S/S 2013 **04**



C 001 650/001 191/001/001AB/234/
001MOL
E P3/P4/S3/S5/S6/S10
S ~179x98
M 4 PCS 23%

12 857 S/S 2013 **06**



C 001LUMG/001VOL/266/001METBL/215
E S6/S8/S16/S20/S30
S ~81x107
M 16 PCS 35%

12 858 S/S 2013 **06**



C 071-001/266/207/001METBL/288
E MST-S3/S6/S6/S6/S6
S ~66x49
M 28 PCS 65%

12 859 S/S 2013 **06**



C 096/092-001/215/001AB/215/
001TRAHFT/001LUMG/213AB
E M2/MSTCS3X3/2035MM6/S3/S3/S6/S10/S16
S ~62x64
M 21 PCS 60%

12 860 S/S 2013 **06**



C 070/070-280HEM/001AB/266/
001VOL/001MOL/280HEM
E M3X3/MST-CS5X2/S5/S6/S6/S8/S10
S ~88x107
M 18 PCS 40%

12 861 S/S 2013 **06**



C 092/070-001/001AB/001VOL/
234/001TRAHFT/266/001METBL
E M2/MSTCS3X3/S3/S6/S8/S8/S10/S20
S ~198x279
M 1 PCS 15%

12 862 S/S 2013 **06**

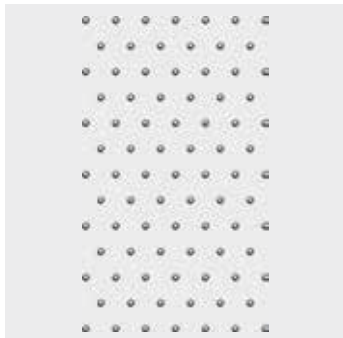

C 280HEM
E S34
S ~175x298
M 3 PCS 14%

12 863 S/S 2013 **10**



C 280/001COP/394/280HEM/266/
280HEM/001COP/394
E P3/S6/S6/S6/S6/S8/S8/S12
S ~67x53
M 42 PCS 60%

12 864 S/S 2013 **10**

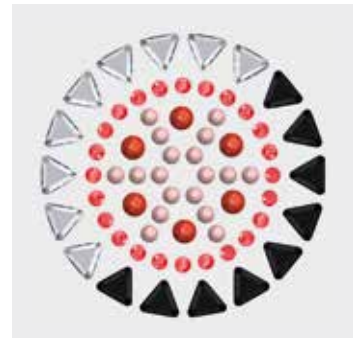

C 001 716/001 718/001/280/262
E P3/P4/CS7X6/CS7X6/S10
S ~47x47
M 45 PCS 80%

12 865 S/S 2013 10

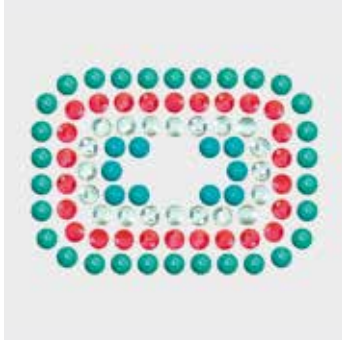

C 001 715/001 709/542/390
E P4/P4/S16/S16
S ~54x39
M 56 PCS 70%

12 866 S/S 2013 10



C 070-280HEM/001 709/390/394
E M3X3-P4/P4/S8/S10
S ~75x25
M 66 PCS 55%

12 867 S/S 2013 10



C 280HEM/220/001MLGLD/001GSHA/
001BRSH
E CS5X2,5/S6/S6/S8/S16
S ~195x93
M 9 PCS 22%

12 868 S/S 2013 10



C 001 709/001 718/246/292/542/
262/360/390
E P4/P4/S10/S16/S16/S16/S20
S ~202x111
M 8 PCS 20%

12 869 S/S 2013 10

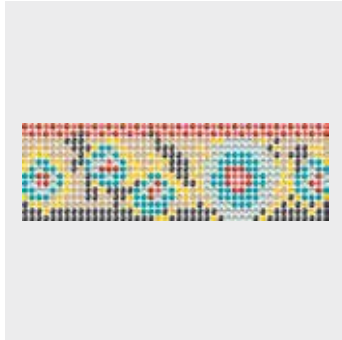

C 070-001 709/001 718/246/292/238/262
E M4-P4/P4/S16/S16/S16/S16
S ~202x64
M 12 PCS 20%

12 870 S/S 2013 10

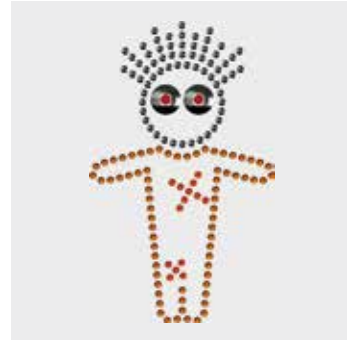

C 070/070-220/236/227
E M2/M8-S6/S6/S10
S ~49x80
M 39 PCS 50%

12 871 S/S 2013 01

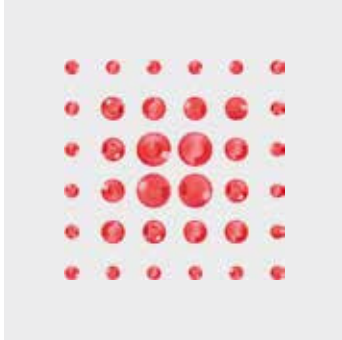

C 262/262/262
E S6/S12/S20
S ~29x29
M 125 PCS 100%

12 872 S/S 2013 03

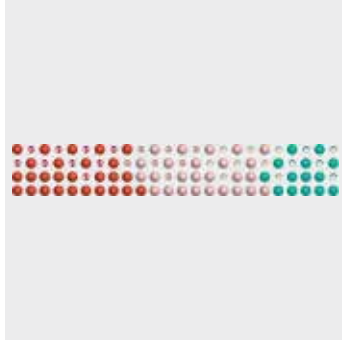

C 001 718/001 716/001 715/289/234/
319/238
E P4/P4/P4/S10/S10/S10/S10
S ~123x20
M 42 PCS 35%

12 873 S/S 2013 08

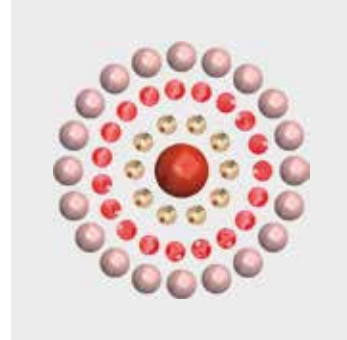

C 001 716/001 718/262/362
E P4/P7/S10/S10
S ~34x34
M 84 PCS 100%

12 874 S/S 2013 08

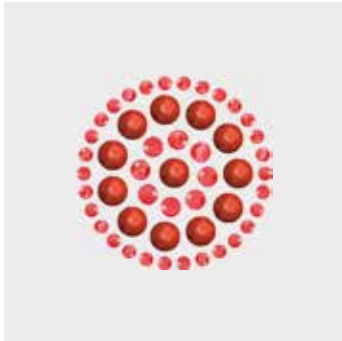

C 001 718/262/262
E P4/S6/S10
S ~26x26
M 162 PCS 100%

12 875 S/S 2013 08



C 223/227/262
E S3/S5/S6
S ~18x18
M 180 PCS 100%

12 877 S/S 2013 08

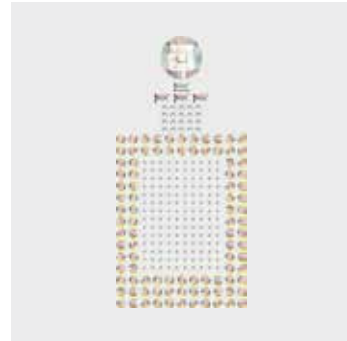

C 001AB/001/001/001/001/001TRAHFT
E CS5X2,5/CS5X2,5/2035MM14/S3/
S6/S12
S ~43x90
M 20 PCS 40%

12 878 S/S 2013 08

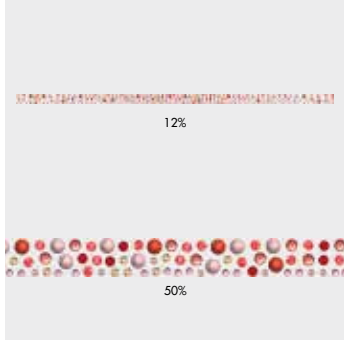

C 001 716/001 718/209/319/362/
262/227/542
E P4/P4/S6/S6/S8/S10/S10/S12
S ~349x10
M 18 PCS

12 880 S/S 2013 08

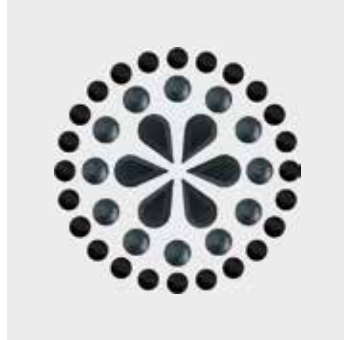

C 280HEM/280HEM/280
E P4/CS8X5/S12
S ~36x36
M 80 PCS 90%

12 881 S/S 2013 08



C 280/280HEM/280
E CS5X2/CS3X3/2035MM10
S ~31x31
M 115 PCS 100%

12 882 S/S 2013 08



C 280/280HEM/280
E 2493MM8/S6/S8
S ~66x26
M 81 PCS 60%

12 883 S/S 2013 08

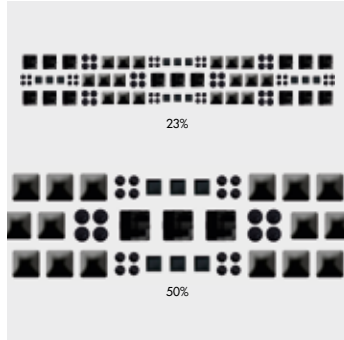

C 070-280/280/280/280
E M7X7-P4/CS4X4/2493MM8/S10
S ~180x29
M 25 PCS

12 884 S/S 2013 08

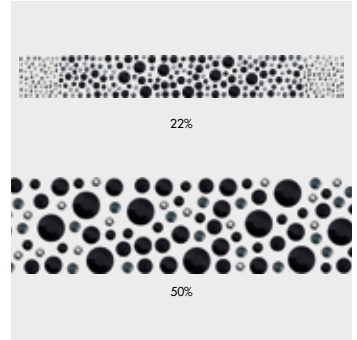

C 070-280HEM/280/215/280HEM/280/
280/280
E M2-P3/P4/S6/S8/S10/S20/S34
S ~195x25
M 23 PCS

12 885 S/S 2013 08

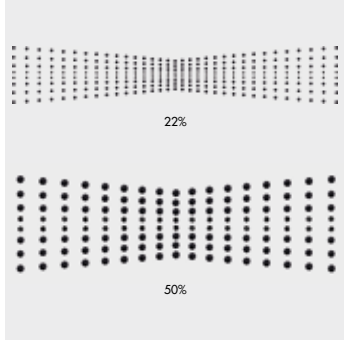

C 280/280/280
E S3/S5/S6
S ~196x34
M 12 PCS

12 886 S/S 2013 08



C 280/280/280
E P3/S5/S8
S ~50x50
M 48 PCS 80%

12 887 F/W 2013/14 04



C 001/001/001/001/001/292
E CS8x4/S3/S5/S6/S8/S16
S ~82x45
M 20 PCS 50%

12 888 F/W 2013/14 04



C 327/246/215
E S3/S3/S3
S ~57x57
M 24 PCS 65%

12 889 F/W 2013/14 04

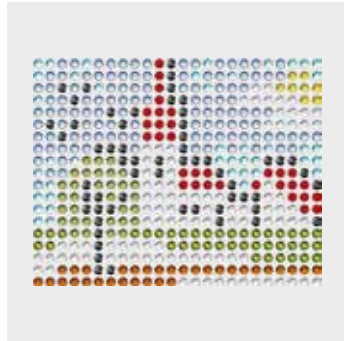

C 070-211/001/202/228/227/550/220/226
E M2-S6/S6/S6/S6/S6/S6/S6/S6
S ~58x46
M 56 PCS 65%

12 890 F/W 2013/14 04



C 246/215/215/001SSHA/001COS/001SSHA
E S3/S3/S3/S6/S6/S8
S ~50x88
M 20 PCS 45%

12 891 F/W 2013/14 04



C	202/214/550
E	S3/S3/S6
S	~79x43
M	24 PCS
	50%

12 892 F/W 2013/14 04

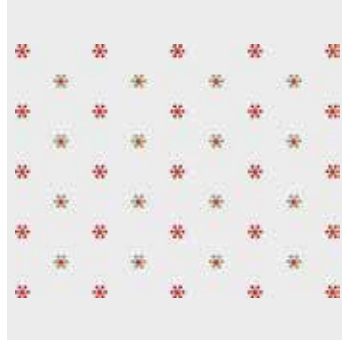

C	001718/227/550
E	P4/S8/S8
S	~225x176
M	4 PCS
	19%

12 893 F/W 2013/14 04



C	001/215/220
E	S3/S5/S6
S	~54x68
M	24 PCS
	60%

12 894 F/W 2013/14 04



C	001HFT
E	S16
S	~179x43
M	20 PCS
	23%

12 895 F/W 2013/14 04



C	094/070-001MLGLD
E	M2/M2,5-S10
S	~117x48
M	21 PCS
	35%

12 896 F/W 2013/14 04



C	001718/001718/001DOR/227SAT/ 327/001MLGLD/550/001TAB
E	P3/P4/S6/S6/S8/S8/S10/S12
S	~138x90
M	12 PCS
	30%

12 897 F/W 2013/14 06



C	070-280HEM/280HEM/215/501
E	M2-CS8x5/CS5x2,5/S5/S8
S	~62x69
M	42 PCS
	60%

12 898 F/W 2013/14 06



C	096-280HEM
E	M2-S6
S	~53x74
M	56 PCS
	55%

12 902 F/W 2013/14 06



C	096-280/215/280HEM/001SSHA/001SSHA
E	M2-S3/S6/S8/S10/S12
S	~164x22
M	21 PCS
	25%

12 904 F/W 2013/14 06

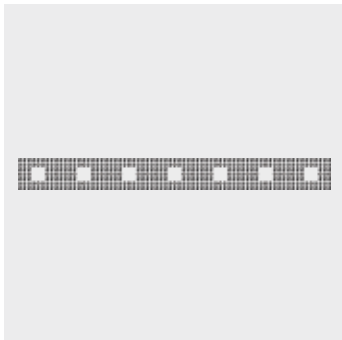

C	070-001COS
E	M2-S6
S	~165x16
M	40 PCS
	25%

12 905 F/W 2013/14 06

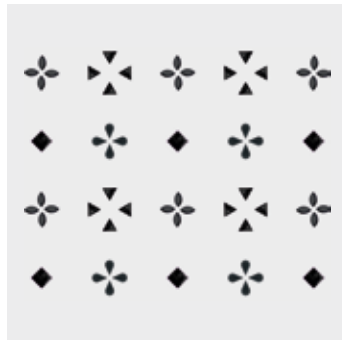

C	280HEM/280/280/280
E	CS8x5/CS8x4/2493MM8/2720MM7,5
S	~162x128
M	6 PCS
	25%

12 906 F/W 2013/14 06



C	001/215/001/280HEM/001SSHA/215
E	S3/S3/S6/S6/S6/S6
S	~71x100
M	12 PCS
	40%

12 907 F/W 2013/14 **10**

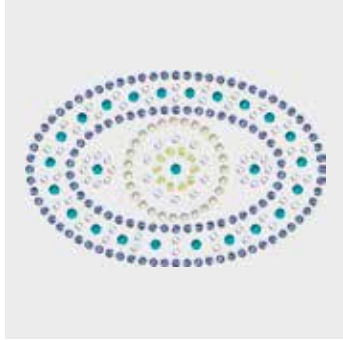

C 001AB/001BLSH/234/001LUMG/263
 E S5/S6/S6/S6/S8
 S ~66x43
 M 54 PCS 60%

12 908 F/W 2013/14 **10**



C 001715/001/390/001LUMG
 E P4/CS8x5/S6/S8
 S ~64x109
 M 27 PCS 35%

12 909 F/W 2013/14 **10**



C 001621/001650/202/001AB/
 001LUMG/266/234
 E P3/P4/S3/S5/S6/S6/S8
 S ~87x56
 M 16 PCS 50%

12 911 F/W 2013/14 **10**



C 001715/001715/001AB/001AB/
 001LUMG/001AB/390/234
 E P3/P4/CS8x5/CS8x4/S6/S8/S8/S8
 S ~97x95
 M 18 PCS 40%

12 912 F/W 2013/14 **10**



C 082/092-001715/001BLSH/001LUMG/
 001SSHA/001SSHA/234
 E M2/M2-P3/S6/S6/S6/S10/S10
 S ~112x181
 M 14 PCS 23%

12 913 F/W 2013/14 **10**



C 001650/001621/001AB/284/263/
 001LUMG/001BLSH
 E P3/P4/CS8x4/S6/S10/S12/S20
 S ~148x40
 M 24 PCS 28%

12 916 F/W 2013/14 **10**



C 001650/234/390/001BLSH
 E P3/S6/S6/S6
 S ~82x127
 M 16 PCS 33%

12 917 F/W 2013/14 **10**



C 082-001650/001LUMG/001TRAHFT
 E M2-P3/S6/S8
 S ~147x36
 M 24 PCS 29%

12 918 F/W 2013/14 **08**



C 071/094/096-001/001AB/001/249
 E M7x7/M7x7/M7x7-CS5x2,5/CS3x3/
 2493MM6/S10
 S ~64x64
 M 39 PCS 55%

12 920 F/W 2013/14 **08**

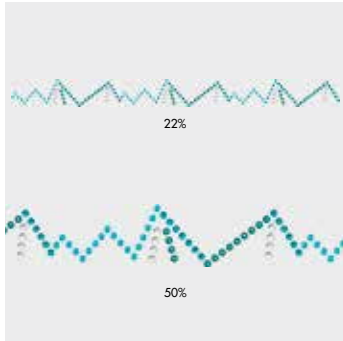

C 071-229/263/001
 E M2-S6/S6/S6
 S ~981x16 [15 SEG/ROW]
 M 8 ROWS

12 922 F/W 2013/14 **08**



C 071/092-001709/001BLSH/001SSHA
 E M3x3/M3x3-P4/S12/S12
 S ~971x4 [43 SEG/ROW]
 M 12 ROWS 60%

12 923 F/W 2013/14 **08**



C 071-279NAC/001709/001BLSH/
 001AB/001SSHA/291/249/263
 E M10P4/P7/2204MM6/S3/S6/S10/S12/S34
 S ~145x160
 M 3 PCS 25%

12 924 F/W 2013/14 08



C	263/001BLSH
E	S10/S10
S	~85x108
M	16 PCS
	35%

12 925 F/W 2013/14 08



C	071/094-001
E	M7x7/M7x7-2483MM10
S	~107x157
M	10 PCS
	25%

12 926 F/W 2013/14 03

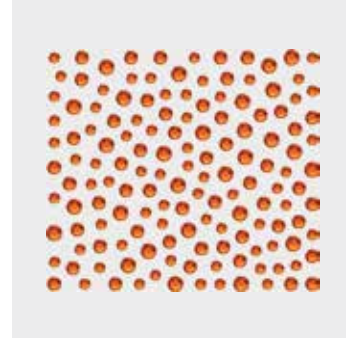

C	248/248/248
E	S6/S8/S10
S	~46x41
M	68 PCS
	78%

12 927 F/W 2013/14 03



C	248/001SSHA/001MOL/657/001SSHA/001SSHA/657/001SSHA/657
E	S6/S8/S8/S10/S10/S12/S16/S16/S20
S	~103x64
M	24 PCS
	40%

12 928 F/W 2013/14 03

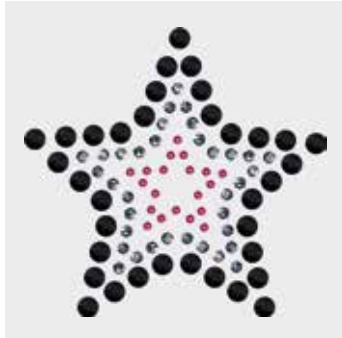

C	502/653/280
E	S6/S10/S20
S	~66x64
M	24 PCS
	60%



12 930 04



C	001616/001/001SSHA/001SINI/001LUMG/001SSHA
E	P3/CS3x3/2770MM60x35/S6/S8/S10
S	~59x59
M	42 PCS
	65%

12 931 04



C	092/096/092-001616/001/001/001/213
E	M3x3/M10x3/M7x3-P4/CS5x2/CS5x2,5/CS4x4/S6
S	~87x23
M	54 PCS
	50%

12 932 04

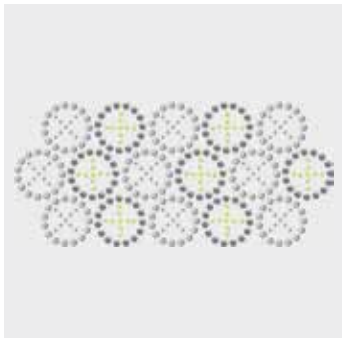

C	096/086-001/213
E	M2/M2-S3/S3
S	~84x38
M	25 PCS
	50%

12 933 04

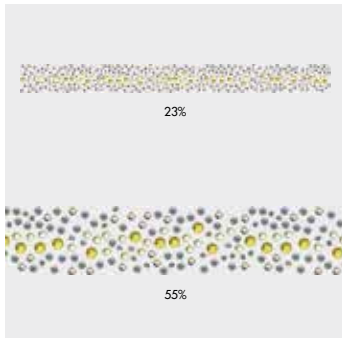

C	086-215/213/001SSHA/226
E	M2-S3/S6/S6/S10
S	~473x16 (8 SEG/ROW)
M	68 PCS 8 ROWS

12 934 04



C	092/096-001/001SINI/213
E	M2/M2-S6/S6/S6
S	~31x88
M	50 PCS
	45%

12 935 04



C 001616/001560/280HEM/280HEM/
001SSHA/001SSHA/001LUMG
E P3/P3/CS3X3/CS4X4/2770MM60X35/S8/S10
S ~67x69
M 36 PCS 55%

12 938 04

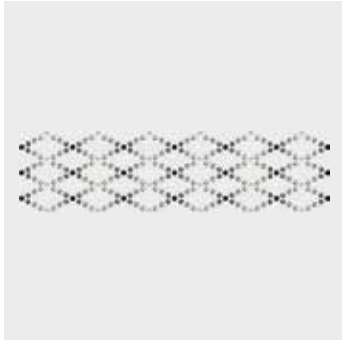

C 001SSHA/215/001SINI/001/280
E S6/S6/S6/S6/S6
S ~117x31
M 35 PCS 35%

12 941 04



C 092/082-001560/001SSHA/001/
001MOL
E M2/M7X3-P3/CS3X3/CS7X6/S8
S ~120x104
M 8 PCS 35%

12 944 10

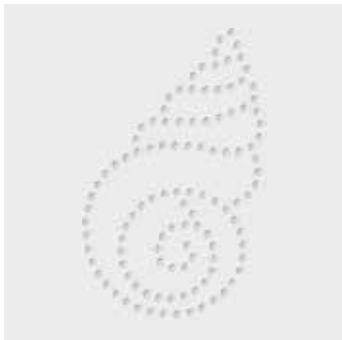

C 001AB
E S3
S ~27x43
M 70 PCS 90%

12 936 04

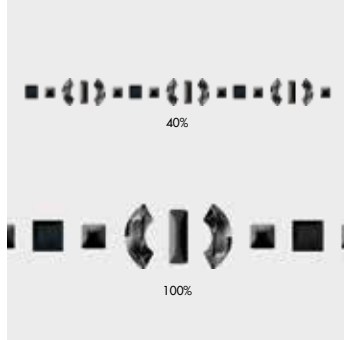

C 070/070-280/280HEM
E M3X3/M7X3-CS4X4/2037MM8
S ~958x8 (28 SEG/ROW)
M 8 ROWS

12 939 04



C 092-001/001SSHA/001SINI
E M2-S5/S8/S10
S ~83x65
M 30 PCS 50%

12 942 05



C 280/280HEM
E CS3X3/CS3X3
S ~198x98
M 9 PCS 20%

12 945 10



C 001/246/261
E S5/S5/S6
S ~34x26
M 144 PCS 100%

12 937 04



C 280/280HEM/001/001SINI/001SSHA/
001MOL
E CS5x2/CS5x2.5/CS4x4/S6/S6/S6
S ~68x25
M 72 PCS 60%

12 940 04

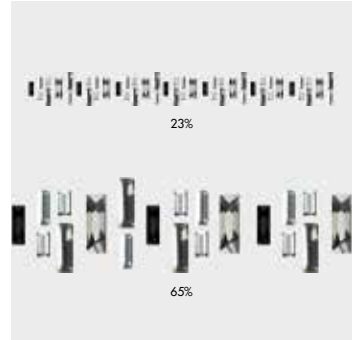

C 096/092-001/280/001SSHA
E M10X3/M7X3-CS5x2.5/2555MM8X2.6/
2555MM12X4
S ~174x19
M 35 PCS

12 943 11



C 001717/001717/211/266/202
E P3/P4/S6/S12/S20
S ~30x22
M 144 PCS 100%

12 946 10



C 001709/001/263
E P3/S3/S6
S ~40x37
M 55 PCS 100%

12 947 10

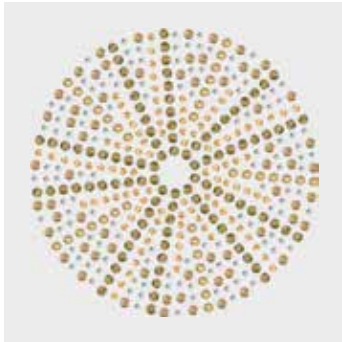

C 084-001/246/246/001MLGLD
E M2/S3/S3/S5/S6
S ~55x55
M 24 PCS 70%

12 948 10



C 001617/246/391/246/001GSHA
E P3/S3/S6/S6/S6
S ~65x87
M 15 PCS 45%

12 949 10



C 202/202/229/266/390/263
E S3/S6/S6/S6/S6/S6
S ~70x94
M 15 PCS 45%

12 950 10

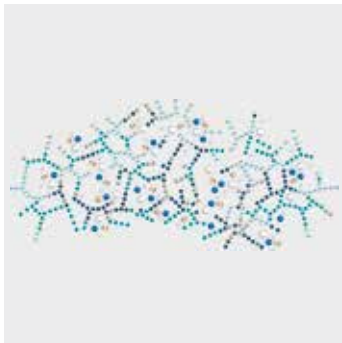

C 001717/001650/263/202/266/
001SSHA/001AB/001TRAHFT
E P3/P4/S6/S6/S6/S6/S12
S ~155x71
M 12 PCS 28%

12 951 10

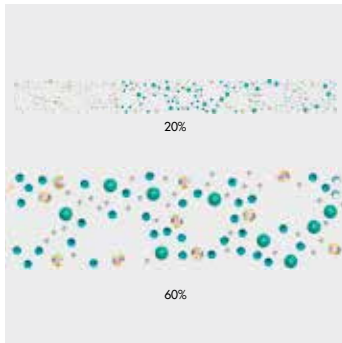

C 001650/001715/001709/001/263/
202/234/261/001TRAHFT
E P3/P3/P3/S3/S6/S6/S6/S6/S10
S ~213x22
M 16 PCS

12 952 10



C 263/234/001HFT
E S6/S6/S6
S ~43x147
M 24 PCS 30%

12 953 10



C 001709/202/263/394
E P3/S3/S6/S8
S ~141x61
M 9 PCS 30%

12 954 10

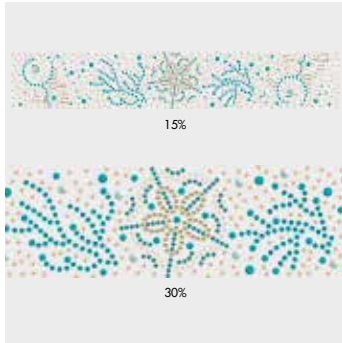

C 094-001709/001616/001709/229/
391/001GSHA/263
E M2-P3/P4/P4/S5/S6/S6/S8
S ~290x50
M 9 PCS

12 955 08

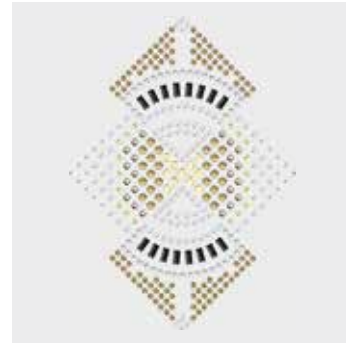

C 280HEM/001/001AB/001/001MLGLD/
001LUMG/001SSHA/001GSHA/261
E CS5X2/S3/S5/S5/S6/S6/S8/S10/S12
S ~75x103
M 15 PCS 40%

12 956 08

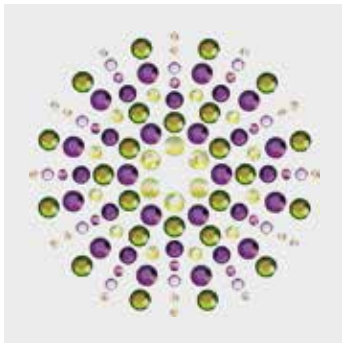

C 001TRAHFT/001ANTP/212/001LUMG/
204/001TAB/001VOL/001LUMG
E S6/S8/S10/S12/S16/S20/S20/S20
S ~64x63
M 39 PCS 60%

12 957 08



C 070/094/090-001VOL/001ANTP/261
E M2/M2/M2-S6/S6/S6
S ~64x87
M 30 PCS 45%

12 958 08

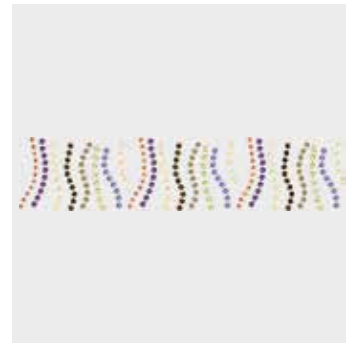

C 952/001VOL/001BRSH/001MLGLD/
539/261/001LUMG
E S6/S8/S8/S8/S8/S10/S10
S ~144x32
M 30 PCS 30%

12 959 08



C 070/096/090-261/952/001LUMG/
001MLGLD
E M2/M2/M2-S6/S6/S6/S6
S ~134x96
M 14 PCS 30%

12 962 08

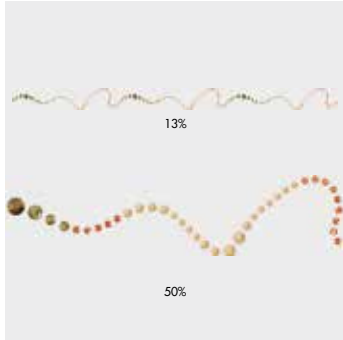

C 094/094/094-952/001MLGLD/
001MLGLD/001DOR
E M2/M2.5/M3-S6/S10/S16/S20
S ~882x21 (8 SEG/ROW)
M 7 ROWS

12 965 07

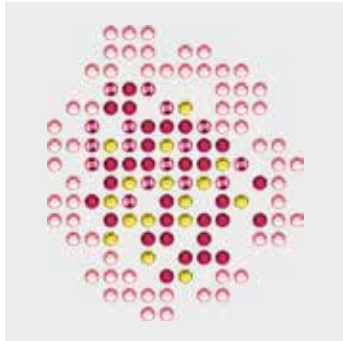

C 223/501/249/289
E S16/S16/S16/S16
S ~68x78
M 24 PCS 50%

12 970 06



C 001296/001AB/223/213/226/291/
001LUMG/289
E P3/S3/S3/S3/S6/S6/S6/S8
S ~82x92
M 15 PCS 45%

12 960 08

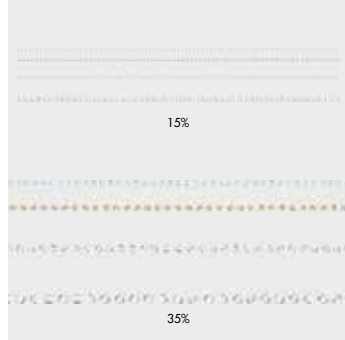

C 001HFT/001TRAHFT/001HFT/001HFT
E S6/S8/S10/S16
S ~285x46
M 9 PCS

12 963 07



C 001/214/291/291/291/291
E 2808MM60/S3/S6/S8/S10/S12
S ~121x74
M 6 PCS 35%

12 968 06

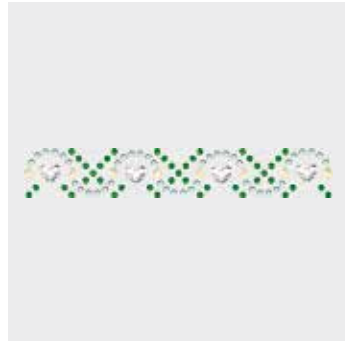

C 001/291/238/261
E 2808MM60/S6/S6/S10
S ~91x15
M 81 PCS 45%

12 971 06

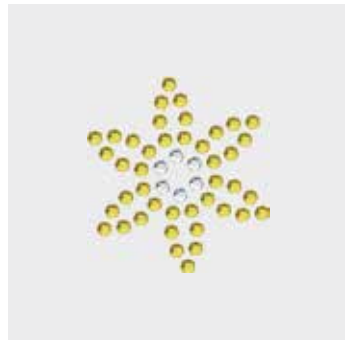

C 226/001
E S6/S6
S ~24x26
M 180 PCS 100%

12 961 08

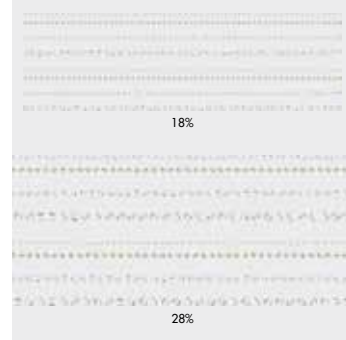

C 001HFT/001TRAHFT/001HFT/001HFT
E S6/S8/S10/S16
S ~234x71
M 8 PCS

12 964 07

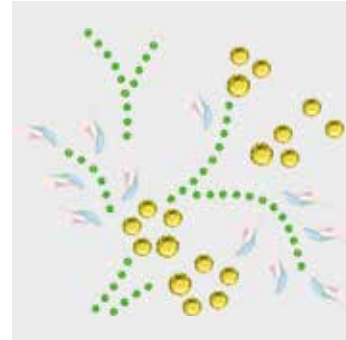

C 001AB/214/249/249
E 2788MM8/S3/S12/S16
S ~55x47
M 24 PCS 80%

12 969 06

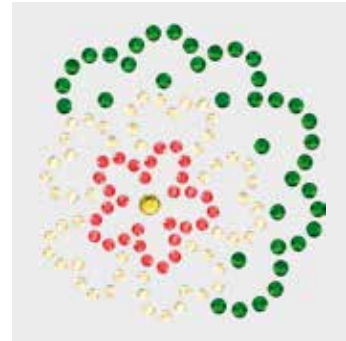

C 261/262/291/249
E S6/S6/S8/S12
S ~42x44
M 76 PCS 90%

12 972 06

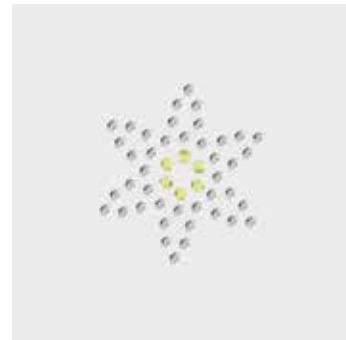

C 001/213
E S3/S3
S ~17x18
M 198 PCS 130%

12 973 06



C 001296/327/280/223/502/
001TRAHFT/289/291/226
E P3/S3/S3/S5/S6/S6/S6/S6/S6
S ~204x62
M 7 PCS 20%

12 976 06



C 001AB
E S3
S ~190x71
M 6 PCS 23%



12 980 04



C 362/001/246
E PP7/PP7/PP12
S ~190x106
M 2 PCS 22%

12 974 06

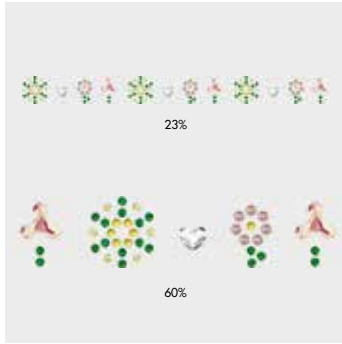

C 001AB/001/291/249/001LUMG/319
E 2708MM8x8,7/2808MM60/S6/S6/S6/S8
S ~960x16 (16 SEG/ROW)
M 8 ROWS

12 977 06



C 001291/001296/001AB/214/001AB/
001/001LUMG/289
E P3/P7/2797MM8x4/2204MM6/
2708MM8x8,7/2808MM60/S8/S34
S ~201x51
M 15 PCS 20%

12 978 04

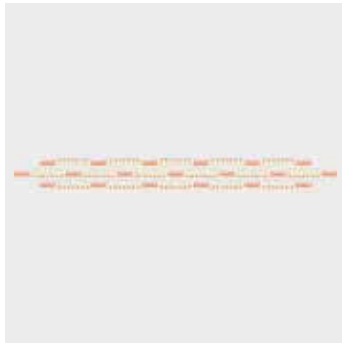

C 080-246/261
E M7X3-S3/S6
S ~142x13
M 33 PCS 30%

12 981 04



C 080-261/001ROGL
E M2-S6/S6
S ~984x7 (202 SEG/ROW)
M 13 ROWS 100%

12 975 06

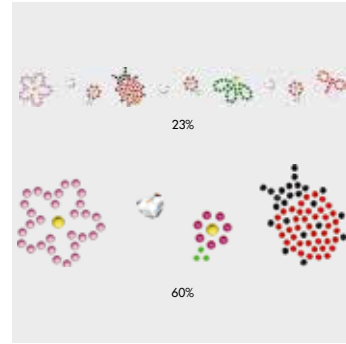

C 001/327/280/223/214/209/291/
502/249
E 2808MM60/S3/S3/S3/S3/S5/S6/S6/S10
S ~188x23
M 17 PCS

12 979 04



C 246/001GSHA/261
E S3/S6/S8
S ~118x11
M 48 PCS 35%

12 982 04



C 001GSHA/001MOL/001ROGL/261
E S6/S6/S6/S6
S ~173x125
M 8 PCS 25%

12 983 04

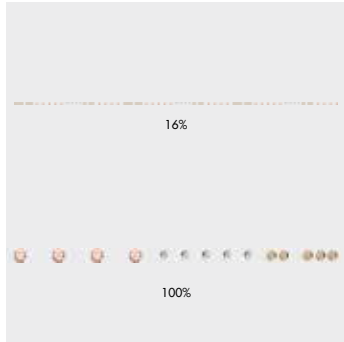

C	246/362/001
E	PP7/PP12/S3
S	~448x2 (5 SEG/ROW)
M	9 ROWS

12 984 04



C	246/001ROGL/261
E	S3/S6/S6
S	~491x3 (24 SEG/ROW)
M	17 ROWS
	65%

12 985 04



C	246/246
E	PP7/S3
S	~468x5 (18 SEG/ROW)
M	7 ROWS
	60%

12 986 04



C	001/246
E	S3/S3
S	~82x349
M	2 PCS
	12%

12 987 04

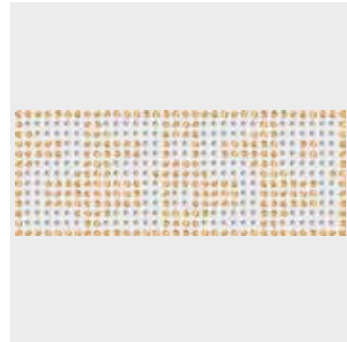

C	246/001
E	S3/S3
S	~62x24
M	49 PCS
	70%

12 988 06



C	001560/215/228/550/284/260/ 001LUMG
E	P3/S5/S6/S6/S6/S8/S10
S	~140x233
M	7 PCS
	18%

12 989 06



C	215/246/228/550/260/001SSHA/ 657HFT/653HFT/652HFT
E	S3/S5/S6/S6/S6/S8/S10/S12/S20
S	~209x98
M	4 PCS
	20%

12 990 06

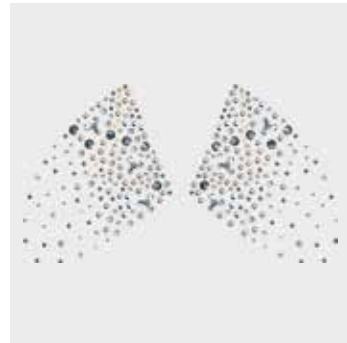

C	001560/001/215/001SINI/001LUMG/ 284/001SSHA/657HFT/653HFT
E	P3/2708MM8x8,7/S3/S6/S6/S8/S10/S12/S20
S	~148x84
M	6 PCS
	28%

12 991 06



C	001/001/260/214/228/360
E	CS4x4/2611MM8/S6/S6/S6/S6
S	~70x42
M	48 PCS
	60%

12 992 06



C	261/261/213/215/001LUMG/261
E	2708MM8x8,7/2708MM12,5x13,6/ S3/S3/S6/S6
S	~71x76
M	18 PCS
	50%

12 993 06



C	261/213/214/291/260/228
E	S6/S6/S6/S6/S6/S6
S	~79x155
M	18 PCS
	25%

12 994 10

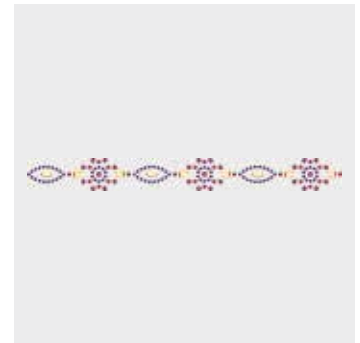

C	001GSHA/001GSHA/204/501/ 001LISH/502
E	CS8x5/CS8x4/S6/S8/S10/S12
S	~951x19 (15 SEG/ROW)
M	7 ROWS
	22%

12 995 10

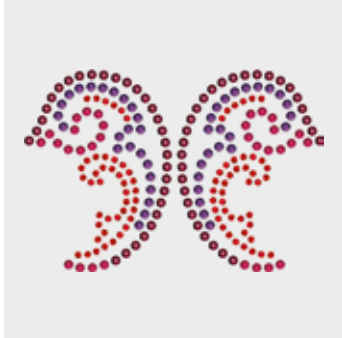

C 327/227SAT/204/501
 E S3/S6/S6/S6
 S ~61x41
 M 30 PCS 65%

12 996 10



C 280HEM/280HEM/308/001/280HEM/
 001LISH/227SAT/515
 E CS8X5/CS5X2/S3/S3/S5/S6/S8/S10
 S ~93x134
 M 8 PCS 30%

12 997 10



C 327/280HEM/227/501/502/001COS/
 327
 E S3/S5/S5/S6/S6/S12/S16
 S ~188x32
 M 12 PCS 22%

12 998 10



C 001718/001617/280HEM/501/501/
 227SAT
 E P3/P4/CS5X2,5/S6/S6/S6
 S ~126x113
 M 14 PCS 33%

12 999 10



C 227/308/501/204/502
 E S5/S6/S6/S6/S6
 S ~132x153
 M 7 PCS 28%

13 000 08

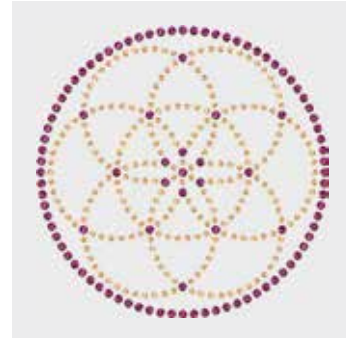

C 246/001LISH
 E S3/S6
 S ~64x64
 M 21 PCS 60%

13 001 08



C 094/084/081-203/001LISH
 E M7X7/M3X3/M7X3-S6/S8
 S ~49x70
 M 36 PCS 55%

13 002 08



C 246/001/203/001MLGLD
 E S5/S5/S8/S8
 S ~63x66
 M 39 PCS 60%

13 003 08



C 084-246/001/203/001COP/246/261
 E M2-S3/S3/S6/S6/S6/S6
 S ~78x78
 M 12 PCS 50%

13 004 08

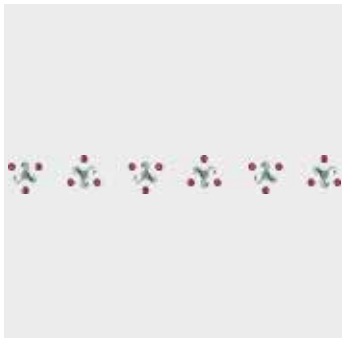

C 001/001LISH
 E 2708MM8X8,7/S10
 S ~940x14 (21 SEG/ROW)
 M 9 ROWS 35%

13 005 08



C 094-246/204/001LISH
 E M2-S3/S3/S6
 S ~498x7 (26 SEG/ROW)
 M 13 ROWS 70%

13 006 08



C 001GSHA/001COP
 E 2770MM60X35/S10
 S ~971x3 (35 SEG/ROW)
 M 11 ROWS 50%

13 007 08



C	220/246/001USH/203/001COP/001BRSH/246	
E	S3/S3/S6/S6/S8/S8	
S	~119x71	
M	10 PCS	35%

13 010 03

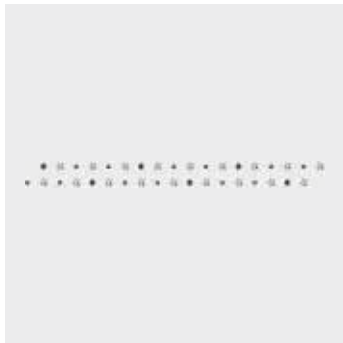

C	280HEM/001/001SINI	
E	P3/2817MM5/S8	
S	~981x13 (19 SEG/ROW)	
M	9 ROWS	25%



13 014 06



C	094-001414/001295/001GSHA/280HEM/280/001GSHA/266/259	
E	M2.5-P3/P4/CS4x4/CS7x6/2493MM12/2611GMM14/S6/S8	
S	~97x135	
M	12 PCS	30%

13 008 08



C	203	
E	S6	
S	~985x2 (299 SEG/ROW)	
M	18 ROWS	100%

13 009 02



C	001/001/001/001/001/001	
E	2611MM8/2611MM8/2611MM10/2611MM10/2611MM14/S10	
S	~115x69	
M	16 PCS	35%

13 011 06



C	280HEM/280/248/001ROGL/203/280HEM/655HFT/207	
E	CS5x2/CS4x4/S6/S6/S6/S6/S8/S16	
S	~78x36	
M	40 PCS	50%

13 012 06



C	090-001GSHA/220/207/248	
E	M7x3-CS4x4/S3/S3/S6	
S	~59x9	
M	98 PCS	70%

13 015 06



C	001414/203/001ROGL/655HFT/001COP	
E	P3/S6/S6/S8/S8	
S	~78x44	
M	34 PCS	55%

13 016 06



C	080/080/080/080-220SAT/001BRSH/001ROGL	
E	M3/M6/M3x3/M7x3-S8/S10/S20	
S	~210x51	
M	14 PCS	20%

13 017 06



C 246/280HEM/220SAT/259/001ROGL
 E S5/S5/S6/S8/S10
 S ~65x65
 M 39 PCS 60%

13 018 06



C 001296/280HEM/220/001ROGL/
 001COP/259
 E P3/CS5x2/S3/S6/S8/S20
 S ~106x79
 M 12 PCS 40%

13 019 04



C 391/261/362
 E S6/S10/S20
 S ~86x98
 M 20 PCS 40%

13 020 04

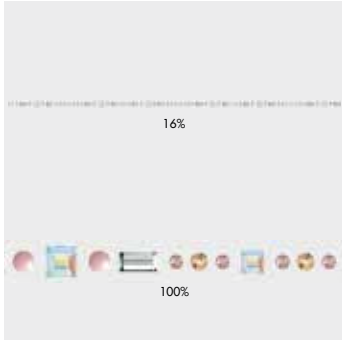

C 001294/001/001AB/001AB/319/362/234
 E P3/CS5x2.5/CS3x3/CS4x4/S6/S8/S8
 S ~950x4 (11 SEG/ROW)
 M 13 ROWS

13 021 04

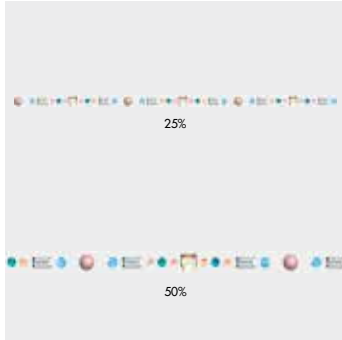

C 001716/001/001AB/362/263/202
 E P4/CS5x2.5/CS4x4/S6/S8/S10
 S ~963x4 (18 SEG/ROW)
 M 12 ROWS

13 022 04

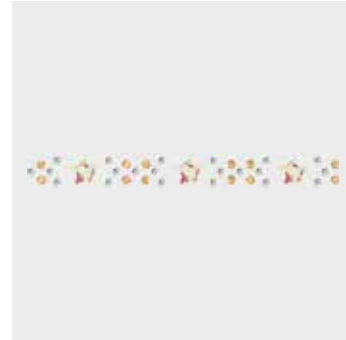

C 001AB/001/246
 E 2817MM5/S3/S3
 S ~502x5 (31 SEG/ROW)
 M 15 ROWS 85%

13 023 04



C 001709/263/229/229/263
 E P3/2708MM8x8.7/
 2708MM12.5x13.6/S10/S12
 S ~61x86
 M 44 PCS 45%

13 024 04



C 080/080-001716/001AB/001/001AB/
 362/259
 E M2/M7x3P3/CS5x2.5/CS3x3/CS7x6/S8/S10
 S ~172x122
 M 7 PCS 25%

13 025 04

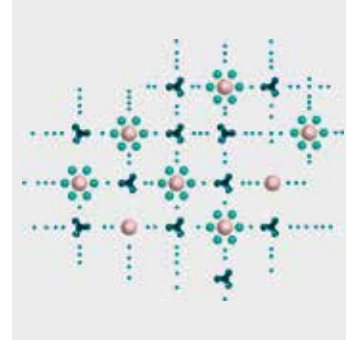

C 001715/001716/229/263
 E P4/P7/2708MM8x8.7/S6
 S ~141x115
 M 8 PCS 30%

13 026 04

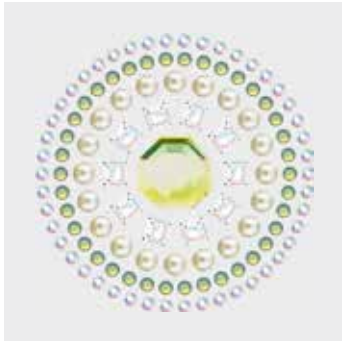

C 001291/001AB/001LUMG/001AB/390
 E P3/CS3x3/2611MM10/S5/S6
 S ~37x37
 M 84 PCS 100%

13 027 04

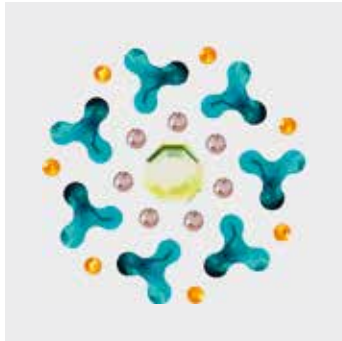

C 263/001LUMG/259/319
 E 2708MM8x8.7/2611MM8/S8/S10
 S ~35x34
 M 84 PCS 100%

13 028 04

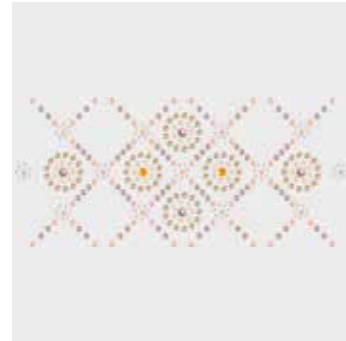

C 080-001716/001AB/362/319/391/259
 E M2-P3/S3/S6/S6/S6/S10
 S ~110x49
 M 16 PCS 40%

13 029 04



C 001716/001AB/001LUMG/391/259/259
E P3/2035MM6/2611MM14/S8/S10/S20
S ~82x34
M 48 PCS 50%

13 030 07

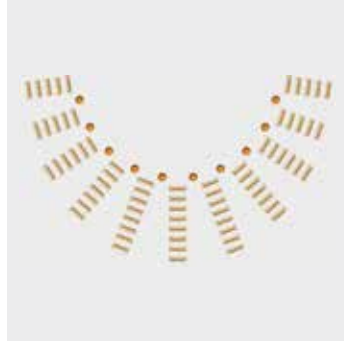

C 094-203
E M10x3-S20
S ~176x106
M 8 PCS 23%

13 031 10



C 001CHRMV/280HEM/280/280HEM/
001MLGLD/280HEM
E P7/P7/CS5x2.5/CS3x3/S12/S12
S ~308x186
M 3 PCS 14%

13 032 10

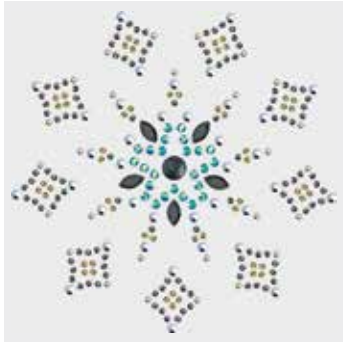

C 001CHRMV/280HEM/280HEM/
001SINI/001MLGLD/001SSHA/001IRIG
E P3/P7/CS8x4/S6/S6/S6/S10
S ~95x94
M 18 PCS 45%

13 033 10



C 070-001CHRMV/280HEM/215/001IRIG
E M12x6-P3/CS7x6/S3/S6
S ~74x74
M 12 PCS 50%

13 034 10

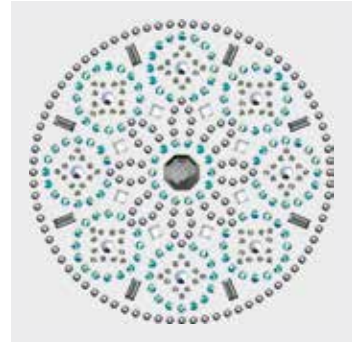

C 001CHRMV/280HEM/001/001SINI/
215/280HEM/001IRIG
E P3/CS5x2/CS3x3/2611MM8/S3/S5/S6
S ~67x67
M 18 PCS 60%

13 035 10



C 001CHRMV/001CHRMV/280HEM/001SSHA/
280HEM/215/001MLGLD/001SSHA/001IRIG
E P3/P7/CS8x4/CS8x4/CS5x2/S3/S6/S6/S10
S ~71x71
M 18 PCS 55%

13 036 10



C 001CHRMV/280HEM/215/001AB/
001MLGLD/001IRIG/001SINI/001COS
E P3/CS5x2/S3/S5/S6/S6/S8/S12
S ~110x110
M 4 PCS 35%

13 037 10



C 070-280HEM/001SINI/001SINI/280HEM
E M12x6-CS5x2/2611MM10/S6/S6
S ~56x56
M 45 PCS 70%

13 040 08



C 070-280HEM/001COS/259/502/260
E M2-2037MM8/S6/S6/S6/S8
S ~151x151
M 8 PCS 25%

13 041 08

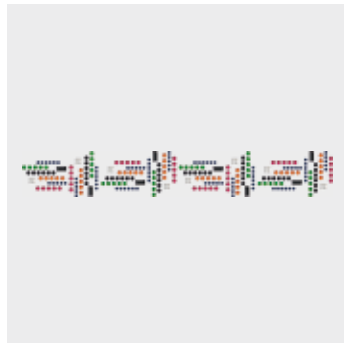

C 280HEM/001/207/280/501/248/291
E CS5x2/CS3x3/S3/S5/S6/S6/S6
S ~147x21
M 21 PCS 28%

13 042 08

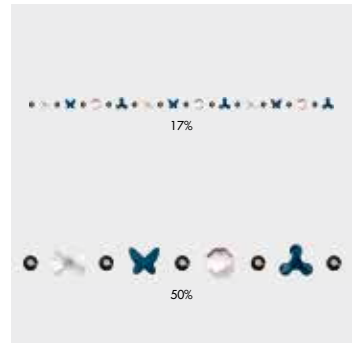

C 266/266/001/001/001COS
E 2708MM8x8.7/2855MM8/2611MM8/
2858MM9x6.5/S16
S ~956x9 (12 SEG/ROW)
M 9 ROWS 35%

13 043 08

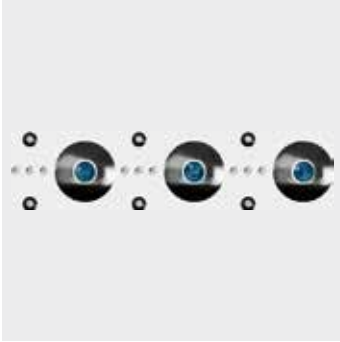

C 070-001/001COS/266
 E M8-S3/S6/S10
 S ~503x10 (35 SEG/ROW)
 M 11 ROWS 100%

13 044 08

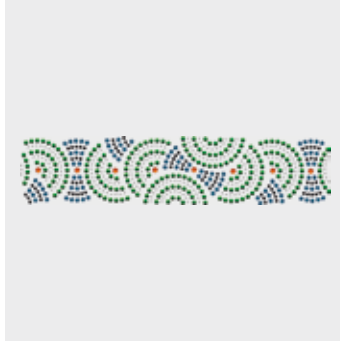

C 001/280/260/266/248/248
 E S3/S3/S6/S6/S8/S8
 S ~137x30
 M 18 PCS 30%

13 045 08

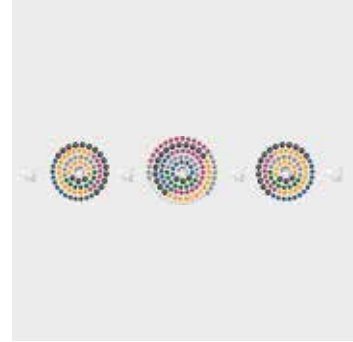

C 001/001/280HEM/259/502/266/
 260/001COS/001
 E 2855MM8/S3/S5/S6/S6/S6/S6/S8/S20
 S ~143x30
 M 18 PCS 30%

13 046 08

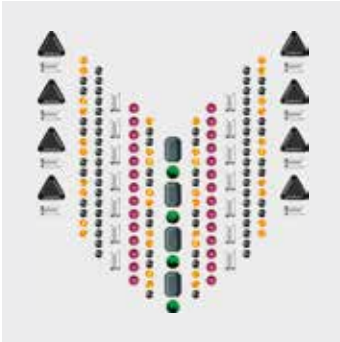

C 070-280HEM/001/280HEM/259/502/260
 E M2-CS6x4/CS5x2/CS7x6/S6/S8/S12
 S ~65x67
 M 24 PCS 55%

13 047 08

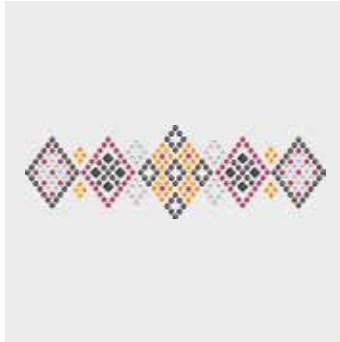

C 280HEM/001/001COS/502/259
 E CS3x3/S5/S6/S6/S6
 S ~113x35
 M 40 PCS 35%

13 048 08

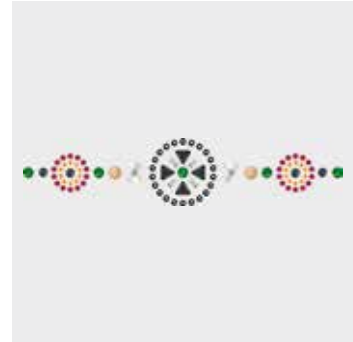

C 094-280HEM/001/280HEM/001/259/
 501/001COS/291
 E M6-P4/CS5x2/CS7x6/2858MM9x6.5/
 S6/S8/S10/S20
 S ~140x30
 M 30 PCS 30%

SPECIAL COLLECTIONS

A wide range of special edition Transfers serve a variety of market segments and very specific needs. Included in the current special edition range are different motifs suitable for lingerie, sports and casual wear, bridal wear, and interior design.



18 525 Romantic 2



C	001/001AB
E	PP7/S6
S	~479x9 (15 SEG/ROW)
M	6 ROWS
	46%

18 541 Glamour 2/04

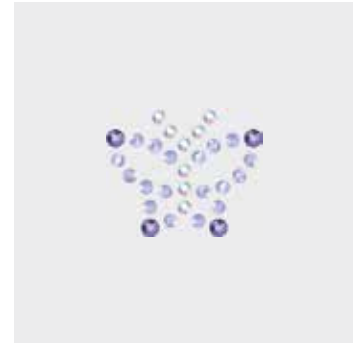

C	283/001AB/539
E	S6/S6/S8
S	~21x17
M	264 PCS
	100%

18 542 Glamour 2/04



C	001ANTP/001AB
E	PP7/S6
S	~18x16
M	120 PCS
	100%

18 910 01



C	001/213/202
E	CS3X3/S8/S10
S	~22x14
M	336 PCS
	100%

18 911 01



C	001560/234/001MOL
E	P3/S6/S6
S	~28x19
M	190 PCS
	100%

18 912 01

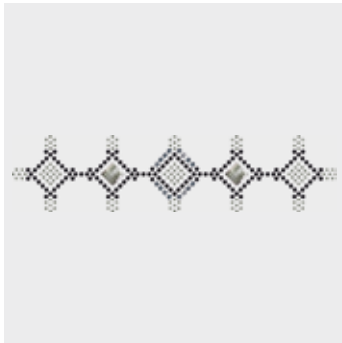

C	001/215/280/653HF
E	2493MM8/S3/S6/S8
S	~153x36
M	15 PCS
	28%

18 914 02



C	001TRAHFT/001AB/319/209
E	S6/S6/S6/S10
S	~26x29
M	189 PCS
	100%

18 915 02



C	001295/001AB/246/213/223/214
E	P3/S3/S3/S3/S3/S3
S	~53x39
M	32 PCS
	80%

18 916 03



C	070-280
E	M2-S3
S	~119x80
M	10 PCS
	35%

18 917 03



C	070-280
E	M2-S3
S	~85x59
M	18 PCS
	50%

18 918 04



C	001295/001/001/001SSHA/ 001ROGL/001SSHA/001ROGL
E	P4/CS8X5/CS8X4/S8/S10/S10/S20
S	~51x56
M	48 PCS
	70%

18 919 04



C	001GSHA/280/246/280/001
E	CS3X3/S3/S3/S5/S5
S	~37x37
M	65 PCS
	100%

18 920 04



C	280/280HEM/001SSHA
E	P3/S6/S8
S	~48x64
M	54 PCS
	60%

18 921 04



C	001GSHA/246/280
E	CS3X3/S3/S6
S	~498x14 (23 SEG/ROW)
M	8 ROWS
	60%

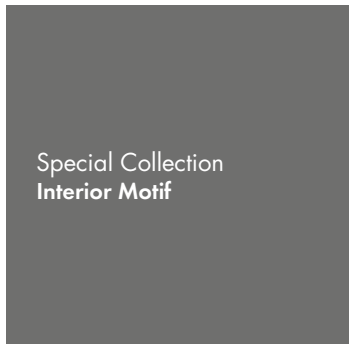

Special Collection
Interior Motif

12 559



C	001/001MOL/001SSHA/215
E	S6/S6/S6/S6
S	~32x32
M	115 PCS
	100%



Special Collection
Playful Motifs

18 680



C	001SSHA
E	PP7
S	~13x13
M	105 PCS
	100%

18 892 01



C	001/001AB/234
E	S3/S5/S6
S	~15x15
M	230 PCS
	100%

18 893 01

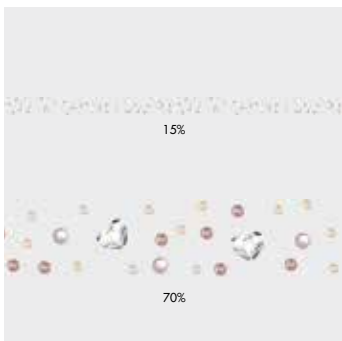

C	001621/001/391/319
E	P3/2808MM60/S6/S8
S	~893x15 (6 SEG/ROW)
M	8 ROWS

18 894 01

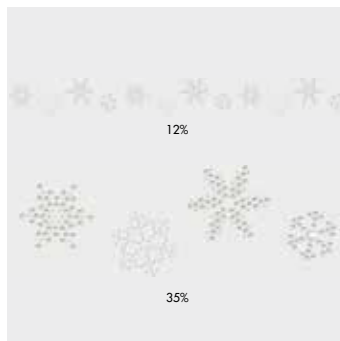

C	001650/001AB/001/234
E	P4/S3/S5/S6
S	~497x42 (4 SEG/ROW)
M	4 ROWS

18 895 01

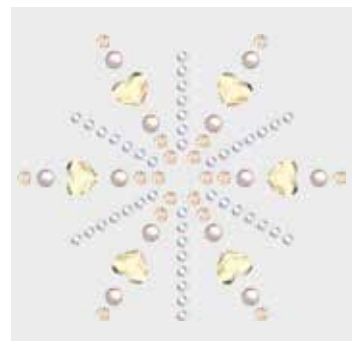

C	001621/261/001AB/391
E	P3/2808MM60/S6/S8
S	~54x47
M	51 PCS
	80%

Transfers

Special Collections

18 896 01



C	001LUMG/001/001AB
E	PP7/S3/S5
S	~49x55
M	18 PCS
	70%

18 897 01

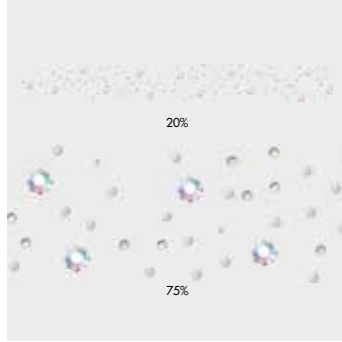

C	092-001AB/001AB/001/234
E	M2-CB20/S3/S5/S6
S	~205x24
M	15 PCS

18 898 01



C	362/001AB
E	PP7/S5
S	~23x22
M	72 PCS
	100%

18 899 01



C	001650/001/001/234/001AB
E	P3/CS5X2/S3/S6/S8
S	~47x54
M	32 PCS
	60%

18 900 02

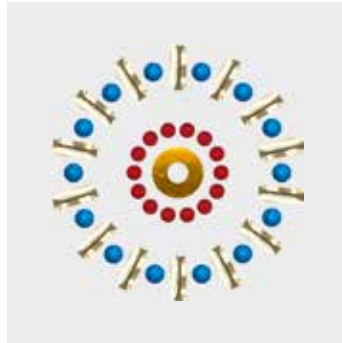

C	091/091-001717/227
E	M8/M7X3-P3/S8
S	~39x40
M	80 PCS
	85%

18 901 02



C	327/246/292/502/227
E	S3/S3/S6/S6/S10
S	~39x34
M	70 PCS
	100%

18 902 02



C	229/001/292/291/238/207/001COS
E	S5/S5/S6/S6/S6/S6/S8
S	~36x60
M	75 PCS
	70%

18 903 02



C	246/220/228/001COS/319
E	S5/S6/S6/S6/S12
S	~65x96
M	27 PCS
	40%

18 904 02



C	227/502
E	S8/S10
S	~47x46
M	68 PCS
	80%



18 905 03

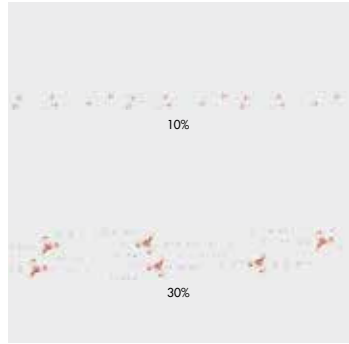

C 001AB/001AB/001AB
E 2708MM8x8.7/S3/S6
S ~448x23 (3 SEG/ROW)
M 6 ROWS

18 906 03

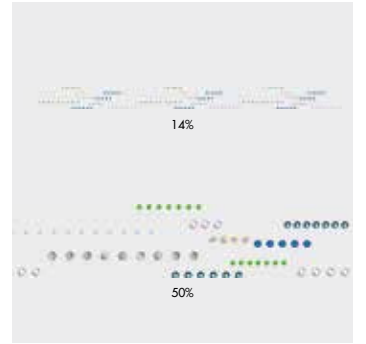

C 214/001AB/280AB/243/001TRAHFT/
001AB/657HFT
E S3/S3/S6/S6/S6/S8/S8
S ~494x19 (5 SEG/ROW)
M 7 ROWS

18 907 03

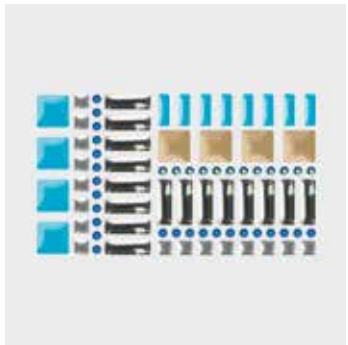

C 071/094/092/096/071-243/280AB
E M7x7/M7x7/M3x3/M10x3/M7x3-S6/S6
S ~61x35
M 66 PCS 60%

18 908 02



C 090/080-001AB/261/001ROGL/261
E M3x3/M7x3-2797MM8x4/S6/S8/S10
S ~50x79
M 32 PCS 50%

18 909 02



C 001650/294/390/213
E P3/S6/S6/S6
S ~115x53
M 24 PCS 38%

18 922 01



C 084/094/094-203/001MLGLD/266/001LISH
E M7x7/M3x3/M7x3-S6/S8/S10/S10
S ~138x115
M 14 PCS 30%

18 923 01



C 084-001MLGLD/220
E M2-S6/S6
S ~148x70
M 18 PCS 30%

18 924 01

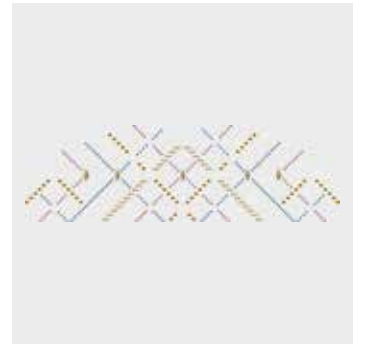

C 091/094/084-266/001LISH
E M3x3/M7x3/M12x6-S6/S6
S ~319x97
M 6 PCS 13%

18 925 01



C 084/096-246/220/001MLGLD
E M2/M2-S3/S6/S6
S ~105x98
M 10 PCS 40%



18 866



C	001GSHA/208/001COP/208	
E	CS8X4/S6/S6/S8	
S	~224x262	
M	4 PCS	15%

18 868



C	001GSHA/246/213SAT/001MLGLD/220SAT	
E	S6/S6/S6/S6/S6	
S	~465x112	
M	2 PCS	9%

A special motif is any individual design created by the customer, which is different from the Transfers Standard, Crystal Inspirations, or Special Collections. This service opens up many customization possibilities. There is also no need to set a motif by hand. You can rely on Swarovski's longtime experience and design expertise and can order a convenient, ready-to-apply design. A range of customization options for existing motifs is available (see "Customization Possibilities" below). You may also submit sketches of a design that will suit your special needs – such as a brand image or an image to suit a particular sales campaign or garment. This will then be made up according to your specifications using Computer Aided Design which allows for easy adjustments according to your needs.

CUSTOMIZATION POSSIBILITIES

- Change of elements of an existing motif
- Change of size of an existing motif
- Logos or brand names
- Creation of pieces or rows
- Up to nine colors possible per Transfer motif

ORDERING PROCESS

Send the request with a drawing you wish to order to your nearest Swarovski sales office. Make sure you include all measurements to the desired motif. Please also indicate, which product group your special motif refers to (Transfers, Crystal-it, Crystal Mesh etc.). You will then receive a quotation including your article number, minimum order quantity, price, and the line drawing of your special motif in PDF format. Please contact your Swarovski sales office again if any changes need to be made. Your special motif will be produced and delivered following your confirmation.

PLEASE NOTE

Please always submit your drawing of the desired motif to represent it in the actual size you require. A small sketch, when enlarged to the desired size, will have blurred lines that will make it difficult to correctly reinterpret. Pictures or drawings representing 100% size of the design or very good quality scans in JPG, BMP or DXF format will ensure that we have clear data to work with. These can also be sent via email or on a CD-ROM. When the sketch is submitted as a hard copy by fax or e-mail, please include a scale legend (e.g. copy/scan with ruler next to the drawing). This will ensure that the desired size of the motif can be identified.

Special productions are generally offered to all our customers if feasibility is given and our General Terms and Conditions are applied. Please note that the simple order of a design does not grant exclusive production of this design to the customer.

CHATON LEATHER

Swarovski has developed and patented a technique that allows the application of Diamond Transfers on leather supplied by the customer. The technique requires a considerable amount of technical know-how and is offered exclusively by Swarovski.

ARTICLE EXPLANATION

Chaton Leather is one of two innovative application solutions developed specially for the leather industry. The technique requires a considerable amount of technical know-how and is offered exclusively by Swarovski.

In general, smooth leather is one of the most captivating but challenging carrier materials when it comes to the application of crystals from Swarovski. A standard Hotfix application is not recommended because of the unique structure of leather and its sensitive treated surface. In response to this, Swarovski has developed and patented a technique that allows the application of Diamond Transfers on leather supplied by the customer. Beside genuine leather, also artificial leather can be used for this technique.

101 611



C	001AB/203
E	PP12/PP12
S	188x188
L	Brown*
M	2 PCS ~30%

101 611	C	E	S	L	M
Article number	Crystal color assortment	Elements	Size of the final leather cut in mm	Color of available standard leather	Minimum order quantity in pieces (PCS)

Product Name	Chaton Leather
Article number range	101 000 – 101 999
Stone	1360 (Diamond Transfers)
Available Diamond Transfers sizes	PP 12 and PP 17 The two crystal sizes can be combined if desired.
Colors and motif selection	This technique can be used for standard motifs and special motifs and offers all the standard colors and effects of the Diamond Transfers range.
Diamond Transfers motif size	The maximum size of the Diamond Transfers motif is 484x340 mm. In general, there is no minimum size for a Diamond Transfers motif.
Type of leather	- Genuine leather - Artificial leather Each leather has to be tested prior to production.
Size of leather	The maximum size of the leather is 500x356 mm. In general, there is no minimum size, though there may be some restrictions in individual cases.
Leather thickness	For crystals of size PP 12, the leather should be between 0.7 and 1.0 mm thick. For crystals of size PP 17, the leather should be between 1.0 and 1.3 mm thick. If both crystal sizes are to be combined in a single motif the leather must be 0.9 to 1.1 mm thick.

ORDERING EXAMPLE & PRODUCT VARIETY EXPLANATION

The order of Chaton Leather includes the Diamond Transfers and the application service. The leather is provided by the customer.

101 611	001 AB	203
Article number	Crystal color according to element 1	Crystal color according to element 2

PROCESS

- Testing and approving the customer's leather for suitability
- Developing the Chaton Leather motif required and drawing up the quotation
- Placing and producing the sample order
- Placing and producing the production order
- Sending the final cut Chaton Leathers to the customer
- Tailored sample and production orders can be requested at your nearest Swarovski sales organization.

DEVELOPING THE CHATON LEATHER MOTIF

- The submission of images and files in an accessible format (JPG, BMP, DXF) that reflect the actual size of the design and are of a good quality, is a major advantage in transforming the design into a Chaton Leather motif.
- Please include the motif size and the dimensions of the leather in your design instructions, while taking into account the final maximum dimensions.

SENDING THE CUSTOMER LEATHER

- To ensure the best possible use of the carrier material, please cut the leather into shape before sending it. Please add an extra 25 mm border on each side, to ensure optimum production results. (Example: if the final piece of leather is to be 100x50 mm, the size submitted must be 150x100 mm.)

AVAILABLE CRYSTAL COLORS & EFFECTS

This technique offers all the standard colors and effects of the Diamond Transfers range.

1360 (with art. 1028 XILION Chaton)

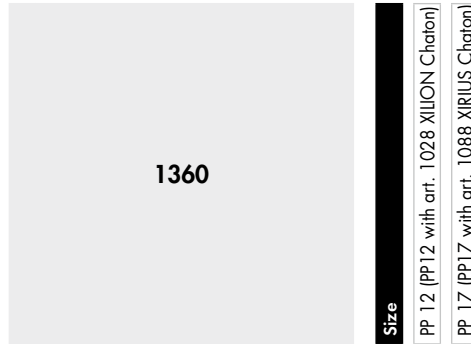
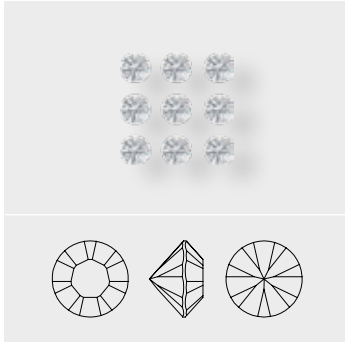

1360 (with art. 1088 XIRIUS Chaton)

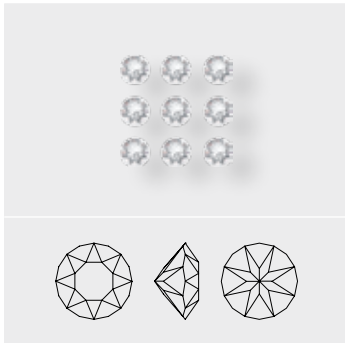

Crystal	
<input type="checkbox"/>	Crystal (001)
Colors	
Plain Colors	
<input type="checkbox"/>	Amethyst (204)
<input type="checkbox"/>	Aquamarine (202)
<input type="checkbox"/>	Dark Indigo (288)
<input type="checkbox"/>	Dark Moss Green F (260)
<input type="checkbox"/>	Denim Blue (266)
<input type="checkbox"/>	Emerald (205)
<input type="checkbox"/>	Fern Green (291)
<input type="checkbox"/>	Jet (280)
<input type="checkbox"/>	Indian Pink (289)
<input type="checkbox"/>	Light Colorado Topaz (246)
<input type="checkbox"/>	Light Peach (362)
<input type="checkbox"/>	Light Rose (223)
<input type="checkbox"/>	Light Sapphire (211)
<input type="checkbox"/>	Light Siam (227)
<input type="checkbox"/>	Light Silk (261)
<input type="checkbox"/>	Light Turquoise (263)
<input type="checkbox"/>	Padparadscha (542)
<input type="checkbox"/>	Peridot (214)
<input type="checkbox"/>	Provence Lavender (283)
<input type="checkbox"/>	Rose Peach (262)
<input type="checkbox"/>	Sapphire (206)
<input type="checkbox"/>	Siam (208)
<input type="checkbox"/>	Smoked Topaz (220)
<input type="checkbox"/>	Sunflower (292)
<input type="checkbox"/>	Tangerine (259)
<input type="checkbox"/>	Tanzanite (539)
<input type="checkbox"/>	Topaz (203)
<input type="checkbox"/>	Vintage Rose (319)

1360

Size

PP 12 (PP12 with art. 1028 XILION Chaton)

PP 17 (PP17 with art. 1088 XIRIUS Chaton)

Crystal Effects

Transparent Effects

- Crystal AB (001 AB)
- Crystal Antique Pink (001 ANTP)
- Crystal Blue Shade (001 BLSH)
- Crystal Lilac Shadow (001 LISH)
- Crystal Luminous Green (001 LUMG)
- Crystal Silver Shade (001 SSHA)

Metallic Effects

- Crystal Iridescent Green (001 IRIG)
- Crystal Metallic Blue (001 METBL)
- Crystal Rose Gold (001 ROGL)

CARE INSTRUCTIONS

- Chaton Leather features natural leather as the carrier material. As leather can be sensitive and react differently to mechanical and chemical stresses, we recommend that it should be cleaned with a soft cotton cloth.
- In general, mild, pH-neutral leather cleaners produced by the leather industry can also be used, although these should be tested before the first application.
- Please obtain further information from your leather supplier in order to achieve the required results.

PLEASE NOTE

Due to technical/production-related tolerances when working with Chaton Leather, the final design may differ slightly from the original. As such, the design or the application (in the wider sense) may be subject to slight variation in each reproduction. As these variations are not considered a defect, no warranty claims may be made against Swarovski.

In addition to the general terms and conditions, special terms and conditions also apply to Chaton Leather. These are included with each quotation.

STANDARD MOTIFS ALREADY APPLIED ON BLACK, BROWN OR WHITE LEATHER

In general the Chaton Leather technique is only offered on leather provided by the customer. However the following standard Chaton Leather motifs are available complete with applied motifs on either standard black, brown or white leather and can be ordered through the Swarovski sales office. Please note that these standard motifs are not available in other sizes or leather colors. Should you require special motifs on your own leather, please contact your Swarovski sales office.

101 601



C	266/001SSHA
E	PP12/PP12
S	96x107
L	Black*
M	4 PCS
	~80%

101 607

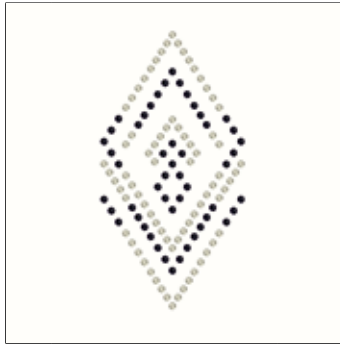

C	001SSHA/280
E	PP17/PP17
S	88x132
L	White*
M	6 PCS
	~70%

101 609



C	001/001AB
E	PP12/PP12
S	84x92
L	Black*
M	8 PCS
	~85%

101 610

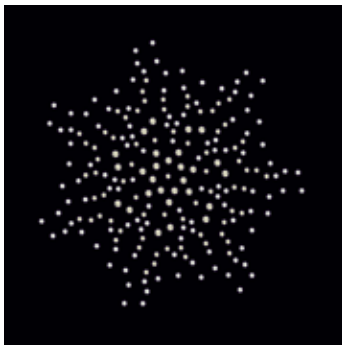

C	001/001SSHA/001SSHA
E	PP12/PP12/PP17
S	120x120
L	Black*
M	3 PCS
	~60%

101 611

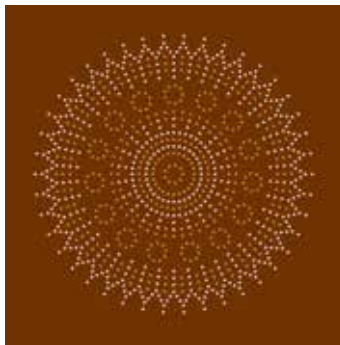

C	001AB/203
E	PP12/PP12
S	188x188
L	Brown*
M	2 PCS
	~30%

101 613

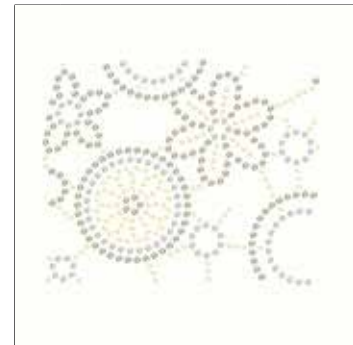

C	001LUMG/001SSHA/001
E	PP12/PP17/PP17
S	125x104
L	White*
M	3 PCS
	~50%

101 732



C	001ROGL
E	PP12
S	118x132
L	Brown*
M	3 PCS
	~40%

101 733

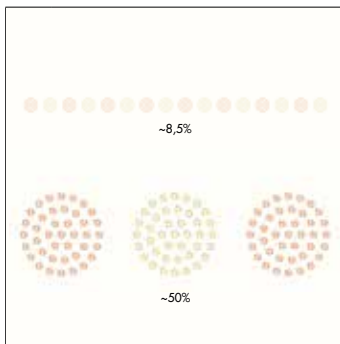

C	362/261
E	PP12/PP12
S	490x30
L	White*
M	3 PCS
	~50%

101 734



C	001/001
E	PP12/PP17
S	490x207
L	Brown*
M	1 PCE
	~10%

* Color of available standard leather.

Synthetics Hotfix

These versatile products open up a multitude of creative design possibilities through their numerous application techniques. They combine elegant crystals from Swarovski that can be applied using Hotfix technology with synthetic carrier materials. They are ideal for use in the textile, interior design, jewelry, and accessories segments.

Crystal Rocks and Crystal Fine Rocks are innovative and stunning design elements that showcase larger and smaller double-pointed chatons.

Crystal Fabric is another inventive product that consists of a carrier material that is completely covered with millions of tiny cut and uncut crystals.

Crystaltex is available in a wide range of colors, effects and a variety of carrier materials to make it the perfect choice for creating a full spectrum of designs.

Small XILION Chatons turn Crystaltex Chaton Bandings and Motifs into an exciting and luxurious statement in the fashion world.

APPLICATION EXAMPLES

Depending on the color and surface of the carrier material, Crystal Fabric with transparent film changes its look dramatically. Please find herein some examples.



Crystal Fabric on a black film creates a deep, mysteriously soft gleam, dressed up with a very alluring sparkle. Surfaces are rendered impenetrably by soft and inky colors that are embellished with shiny crystals.



13 Synthetics Hotfix

57 000	C	W	M	100%
Article number	Color of crystals	Width of the banding	Minimum order quantity in meters (M)	Documentation size in %

OVERVIEW OF AVAILABLE COLORS & EFFECTS

Crystal Aurore Boreale (001 AB)



010 Transparent

012 Black

Crystal Copper (001 COP)



010 Transparent

012 Black

Crystal Golden Shadow (001 GSHA)



010 Transparent

012 Black

Crystal Moonlight Blue (001 MOL)



010 Transparent

012 Black

Crystal Comet Argent Light (001 CAL)



010 Transparent

012 Black

Crystal Dorado (001 DOR)



010 Transparent

012 Black

Crystal Metallic Light Gold (001 MLGLD)



010 Transparent

012 Black

Jet HEM (280 HEM)



012 Black

ORDERING EXAMPLE & PRODUCT VARIETY EXPLANATION

57 000	002	010	001 AB
Article number	3-digit code for width	Color of film	Color of crystals
	001 1 cm	010 Transparent	001 AB Crystal Aurore Boreale
	002 2 cm	012 Black	001 CAL Crystal Comet Argent Light
	003 3 cm		001 COP Crystal Copper
	005 5 cm		001 DOR Crystal Dorado
	010 10 cm		001 GSHA Crystal Golden Shadow
	015 15 cm		001 MLGD Crystal Metallic Light Gold
			001 MOL Crystal Moonlight Blue
			280 HEM Jet Hematite

57 000



W 001, 002, 003, 005, 010, 015
 M 10 M* 100%

57 000

Width in cm	001	002	003	005	010	015	Color of Film	010 Transparent	012 Black
Crystal Effects									
Transparent Effects									
	■	■	■	■	■	■		■	■
	■	■	■	■	■	■		■	■
	■	■	■	■	■	■		■	■
	■	■	■	■	■	■		■	■
Metallic Effects									
	■	■	■	■	■	■		■	■
	■	■	■	■	■	■		■	■
	■	■	■	■	■	■		■	■
Color Effects									
Metallic Effects									
	■	■	■	■	■	■		■	■

* Please note: Bandings can be divided.

ARTICLE EXPLANATION

57 196 S/S 2007 **03**

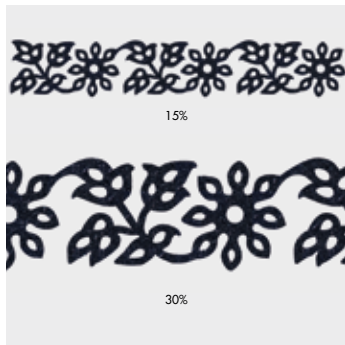

C	012-280HEM
S	~295x50
M	16 PCS

57 196	03	S	M	15%, 30%
Article number	This product is shown on flag number 3.	Motif size in mm	Minimum order quantity in pieces (PCS)	Documentation size in % 15%: total view of motif 30%: enlarged view of motif segment

ORDERING EXAMPLE & PRODUCT VARIETY EXPLANATION

57 196	012	280 HEM
Article number	Color of film	Color of crystals
	010 Transparent 012 Black	001 AB Crystal Aurore Boreale 001 CAL Crystal Comet Argent Light 001 COP Crystal Copper 001 DOR Crystal Dorado 001 GSHA Crystal Golden Shadow 001 MLGD Crystal Metallic Light Gold 001 MOL Crystal Moonlight Blue 280 HEM Jet Hematite

Please note: All motifs are available in certain color/film variations (see colormatrix p. 480).

Synthetics Hotfix

Crystal Fabric Motifs

Standard Collection



57 125



C	012-280HEM	
S	~252x240	
M	3 PCS	17%

57 127



C	012-280HEM	
S	~295x57	
M	15 PCS	15%

57 206



C	012-280HEM	
S	~159x197	
M	8 PCS	20%

57 217



C	012-280HEM	
S	~108x139	
M	18 PCS	30%

57 219



C	012-280HEM	
S	~352x106	
M	7 PCS	12%

57 220

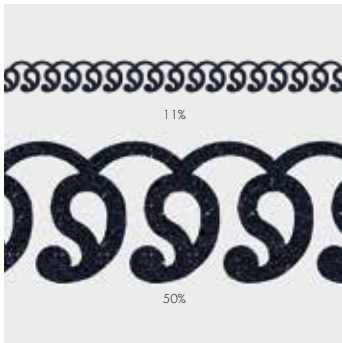

C	012-280HEM	
S	~399x36	
M	14 PCS	

57 305

03



C	012-001MIGLD	
S	~284x60	
M	13 PCS	15%

57 306

03



C	010-001GSHA	
S	~79x76	
M	44 PCS	50%

57 307

03



C	012-001DOR	
S	~83x82	
M	33 PCS	45%

57 308

03



C	012-001DOR	
S	~233x46	
M	24 PCS	18%

57 309

04

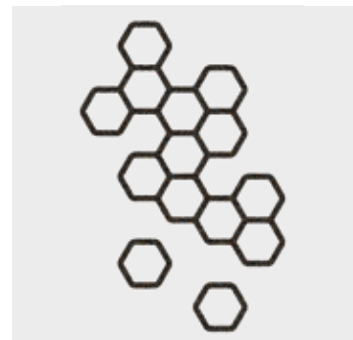

C	012-001DOR	
S	~108x164	
M	16 PCS	25%

Please note: All motifs are available in certain color/film variations (see colormatrix p. 480).

Synthetics Hotfix

Crystal Fabric Motifs

Standard Collection

57 310 **04**



C 010-001GSHA	
S ~95x152	
M 20 PCS	25%

57 311 **04**

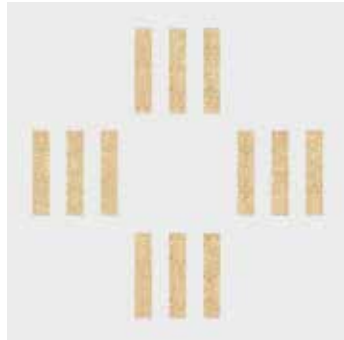

C 010-001GSHA	
S ~85x85	
M 33 PCS	45%

57 312 **04**



C 012-001DOR	
S ~85x85	
M 30 PCS	45%

57 313 **04**

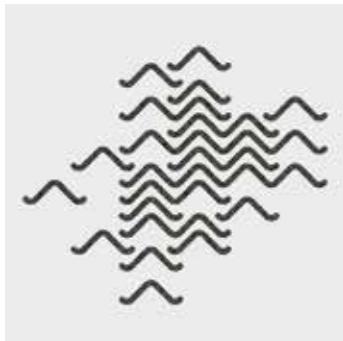

C 012-001MLGLD	
S ~154x131	
M 16 PCS	26%

57 314 **04**



C 010-001GSHA	
S ~52x52	
M 75 PCS	75%

57 315 **04**



C 012-001MLGLD	
S ~62x59	
M 56 PCS	60%

57 316 **03**



C 012-001DOR	
S ~151x208	
M 8 PCS	20%

57 317 **04**



C 012-001DOR	
S ~146x154	
M 12 PCS	25%

57 318 **04**

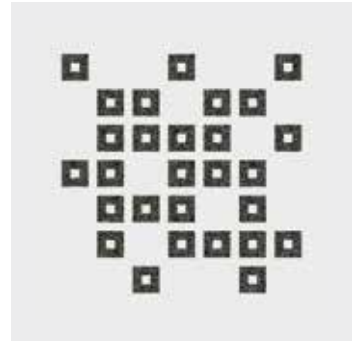

C 012-001MLGLD	
S ~90x90	
M 27 PCS	35%

57 319 **04**



C 010-001GSHA	
S ~116x40	
M 42 PCS	35%

57 320 **04**



C 012-001DOR	
S ~160x40	
M 38 PCS	25%

57 321 **03**



C 012-001MLGLD	
S ~114x86	
M 24 PCS	35%

Please note: All motifs are available in certain color/film variations (see colormatrix p. 480).

Synthetics Hotfix

Crystal Fabric Motifs

Standard Collection

57 322 03



C 010-001GSHA
S ~160x105
M 18 PCS 25%

57 323 04



C 010-001GSHA
S ~293x203
M 4 PCS 15%

57 335 01



C 010-001AB
S ~35x35
M 147 PCS 100%

57 336 01



C 012-001MOL
S ~35x100
M 63 PCS 35%

57 337 01



C 012-001DOR
S ~83x86
M 30 PCS 40%

57 338 01



C 012-001MOL
S ~73x71
M 60 PCS 50%

57 339 01



C 012-001 CAL
S ~75x79
M 44 PCS 50%

57 340 01



C 012-001MIGLD
S ~133x132
M 14 PCS 30%

57 341 01



C 012-001MIGLD
S ~88x149
M 21 PCS 25%

57 342 01



C 012-001MOL
S ~92x109
M 30 PCS 35%

57 343 01



C 010-001AB
S ~52x49
M 102 PCS 80%

57 344 01



C 012-280HEM
S ~109x63
M 32 PCS 35%

Please note: All motifs are available in certain color/film variations (see colormatrix p. 480).

57 345

01



C	010-001GSHA
S	~110x110
M	16 PCS 35%

57 346

01



C	012-001DOR
S	~85x137
M	21 PCS 30%



57 195 S/S 2007 **03**

15%

50%

C	012-280HEM
S	~296x16
M	36 PCS

57 196 S/S 2007 **03**

15%

30%

C	012-280HEM
S	~295x50
M	16 PCS

57 198 S/S 2007 **03**

15%

C	012-280HEM
S	~295x83
M	10 PCS

57 283 S/S 2010 **08**

23%

C	010-001AB
S	~30x174
M	40 PCS

57 300 S/S 2011 **06**

27%

C	012-280HEM
S	~148x120
M	16 PCS

57 302 F/W 2011/12 **06**

80%

C	010-001AB
S	~43x49
M	102 PCS

57 324 S/S 2012 **09**

38%

C	012-001MLGLD
S	~105x107
M	24 PCS

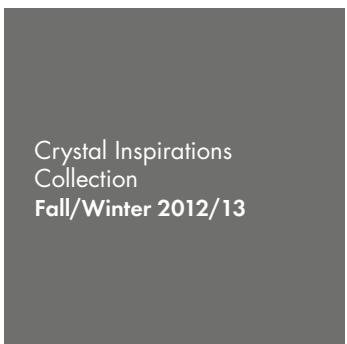

57 325 **09**

50%

C	012-280HEM
S	~80x79
M	33 PCS

57 326 **09**

65%

C	012-280HEM
S	~60x60
M	65 PCS

Please note: All motifs are available in certain color/film variations (see colormatrix p. 480).

57 327 09



C	012-280HEM
S	~51x51
M	96 PCS 80%

57 328 12



C	010-001AB
S	~158x180
M	12 PCS 23%

57 329 12



C	012-001DOR
S	~117x111
M	27 PCS 35%

57 332 09



C	012-280HEM
S	~188x72
M	16 PCS 23%



57 334 04



C	012-001DOR
S	~157x144
M	12 PCS 25%



57 347 11



C	010-001AB
S	~89x158
M	25 PCS 25%

Please note: All motifs are available in certain color/film variations (see colormatrix p. 480).



57 348 03



C	012-001COP	
E	~55x40	
M	95 PCS	70%

57 349 03



C	010-001COP	
E	~55x40	
M	95 PCS	70%



57 350 03



C	012-280HEM	
E	~51x108	
M	33 PCS	40%

A special motif is any individual design created by the customer, which is different from the Crystal Fabric Standard, Crystal Inspirations or Special Collections. This service opens up many customization possibilities and enables you to profit from Swarovski's longtime experience and design expertise. A range of customization options for existing motifs is available (see "Customization Possibilities" below). You may also submit sketches of a design that will suit your special needs – such as a brand image or an image to suit a particular sales campaign. This will then be made up according to your specifications using Computer Aided Design, which allows for easy adjustments according to your needs.

CUSTOMIZATION POSSIBILITIES FOR CRYSTAL FABRIC

- Max. motif size 620x1800 mm
- Min. motif size of 10x10 mm
- Min. width of holes within motifs: 3 mm
- Min. Crystal Fabric surface: 3 mm
- Min. size of the smallest element within a motif: 10x10 mm

ORDERING PROCESS

Send the request with a drawing you wish to order to your nearest Swarovski sales office. Make sure you include all measurements to the desired motif. Please also indicate which product group your special motif refers to (Crystal Fabric). You will then receive a quotation including your article number, minimum order quantity, price, and the line drawing of your special motif in PDF format. Please contact your Swarovski sales office again if any changes need to be made. Your special motif will be produced and delivered following your confirmation.

PLEASE NOTE

Please always submit your drawing of the desired motif to represent it in the actual size you require. A small sketch, when enlarged to the desired size, will have blurred lines that will make it difficult to correctly reinterpret. Pictures or drawings representing 100% size of the design or very good quality scans in JPG, BMP or DXF format will ensure that we have clear data to work with. These can also be sent via email or on a CD-ROM. If sending a sewing pattern, please include the whole pattern and not just cut outs. When the sketch is submitted as a hard copy by fax or e-mail, please include a scale legend (e.g. copy/scan with ruler next to the drawing). This will ensure that the desired size of the motif can be identified.

It is generally possible to draw motifs with a minimum gap of 3 mm between the outlines. However, due to the tolerance level of the crystals being applied onto carrier film, the final Crystal Fabric Motifs may generally differ from the sketches or prints in relation to the motifs' outline, especially with regards to spaces that are smaller than 3 mm. Therefore the motif, and by extension, the product itself, may be subject to individual variations with each reproduction. These variations are caused by technical production-related factors. As these variations are not deemed to be defects, warranty claims shall therefore not be entertained by Swarovski.

Special productions are generally offered to all our customers if feasibility is given and our General Terms and Conditions are applied. Please note that the simple order of a design does not grant exclusive production of this design to the customer.

If detailed information on the possible tolerances is needed (e.g. cavity production for a metal part), please contact Swarovski who will place an application request within our application database.

CRYSTAL ROCKS

The surface and the edges of the innovative and luxurious Crystal Rocks are smooth, which offers a whole new range of application possibilities. Crystal Rocks not only conjures up unique effects on accessories and jewelry, but also enhances textiles in an innovative way.

ARTICLE EXPLANATION

72 000 **01**



C	001 CAL
S	~1.04x98
M	12 PCS 35%

72 000	01	C	S	M	35 %
Article number	This motif is shown on flag number 1.	Color of crystal	Motif size in mm	Minimum order quantity in pieces (PCS)	Documentation size in %

ORDERING EXAMPLE & PRODUCT VARIETY EXPLANATION

72 000	010	001 CAL
Article number	Color of film	Color of crystals
	010 Transparent	001 AB Crystal Aurore Boreale
	012 Black	001 BBL Crystal Bermuda Blue
		001 CAL Crystal Comet Argent Light
		001 GSHA Crystal Golden Shadow
		001 METSI Crystal Metallic Silver
		001 MLGLD Crystal Metallic Light Gold
		001 REDM Crystal Red Magma
		001 SSHA Crystal Silver Shade
		280 Jet
		M 100
		M 101
		M 102
		M 103
		M 104
		M 106
		M 109 Peach Gold

Please note: Crystal Comet Argent Light (001 CAL) is not suitable for swimwear because the effect 001 CAL has a high level of sensitivity to seawater, sweat or chlorine water.

AVAILABLE BASE MATERIALS AND CRYSTAL COLORS & EFFECTS

72 000 onwards

Color of Film

010 Transparent
012 Black

Color

Plain Color

● Jet (280)

Crystal Effects

Transparent Effects

● Crystal Aurore Boreale (001 AB)

● Crystal Bermuda Blue (001 BBL)

● Crystal Golden Shadow (001 GSHA)

● Crystal Red Magma (001 REDM)

● Crystal Silver Shade (001 SSHA)

Metallic Effects

● Crystal Comet Argent Light (001 CAL)

● Crystal Metallic Light Gold (001 MLGLD)

● Crystal Metallic Silver (001 METSI)

72 000 onwards

Color of Film

010 Transparent
012 Black

Multicolors

● Jet & Crystal Metallic Silver (M100)

● Crystal Bermuda Blue & Crystal Metallic Light Gold (M101)

● Crystal Bermuda Blue & Crystal Comet Argent Light (M102)

● Crystal Metallic Light Gold & Crystal Golden Shadow (M103)

● Crystal Metallic Light Gold & Crystal Red Magma (M104)

● Jet & Crystal Comet Argent Light (M106)

Peach Gold (M109)

● Light Peach & Crystal Metallic Light Gold

OVERVIEW OF AVAILABLE COLORS & EFFECTS

Jet (280)



012 Black

Crystal Aurore Boreale (001 AB)



010 Transparent 012 Black

Crystal Bermuda Blue (001 BBL)



012 Black

Crystal Golden Shadow (001 GSHA)



010 Transparent

Crystal Red Magma (001 REDM)



010 Transparent 012 Black

Crystal Silver Shade (001 SSHA)



010 Transparent 012 Black

Synthetics Hotfix

Crystal Rocks

Crystal Comet Argent Light (001 CAL)



010 Transparent

Crystal Metallic Light Gold (001 MLGLD)



010 Transparent

Crystal Metallic Silver (001 METSI)



010 Transparent

012 Black

Jet & Crystal Metallic Silver (M100)



012 Black

Crystal Bermuda Blue & Crystal Metallic Light Gold (M101)



012 Black

Crystal Bermuda Blue & Crystal Comet Argent Light (M102)



012 Black

Crystal Metallic Light Gold & Crystal Golden Shadow (M103)



010 Transparent

012 Black

Crystal Metallic Light Gold & Crystal Red Magma (M104)



010 Transparent

012 Black

Jet & Crystal Comet Argent Light (M106)

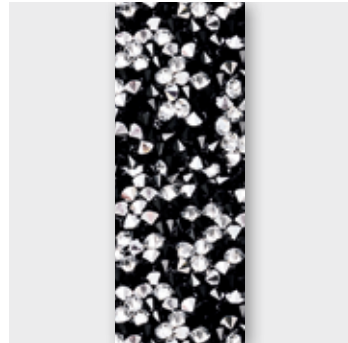

012 Black

Peach Gold (M109)



010 Transparent

012 Black

Synthetics Hotfix

Crystal Rocks

Standard Collection



72 000 01



C	001 GSHA
S	~104x98
M	12 PCS 40%

72 001 01



C	280
S	~80x80
M	12 PCS 45%

72 002 01



C	001 REDM
S	~76x80
M	18 PCS 45%

72 003 01

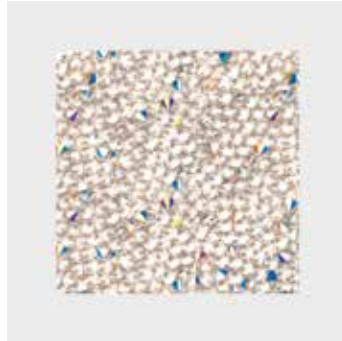

C	001 AB
S	~40x40
M	48 PCS 80%

72 004 01



C	280
S	~43x44
M	42 PCS 80%

72 005 01



C	280
S	~174x48
M	10 PCS 20%

72 006 01



C	001 SSHA
S	~108x138
M	6 PCS 25%

72 007 01



C	001 MLGLD
S	~156x156
M	6 PCS 25%

72 009



C	012-280
S	~35x45
M	54 PCS 80%

72 010

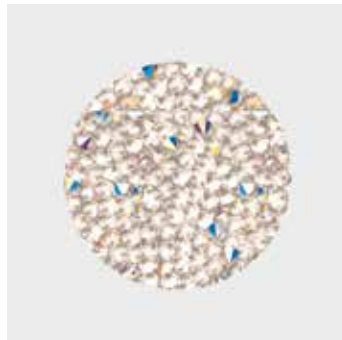

C	001 AB
S	~30x30
M	80 PCS 100%

72 018



C	001 BBL
S	~158x179
M	4 PCS 20%

Please note: All motifs are available in certain color/film variations (see colormatrix p. 491).

Synthetics Hotfix

Crystal Rocks

Standard Collection

72 020



C	280		
S	~40x40		
M	54 PCS	100%	

72 021

02



C	010-001GSHA		
S	~50x50		
M	30 PCS	80%	

72 022

02



C	012-001SSHA		
S	~51x44		
M	54 PCS	70%	

72 023

02

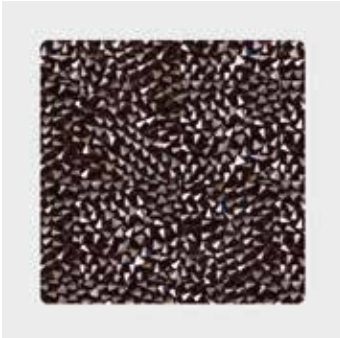

C	012-280		
S	~44x43		
M	42 PCS	80%	

72 024

02

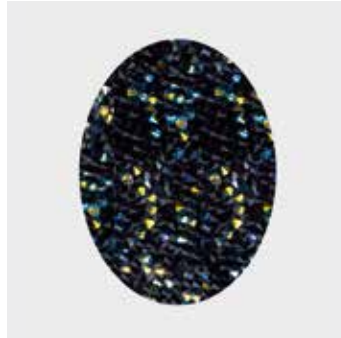

C	012-001AB		
S	~37x50		
M	49 PCS	70%	

72 025

02



C	010-001SSHA		
S	~169x65		
M	8 PCS	25%	

72 026

02

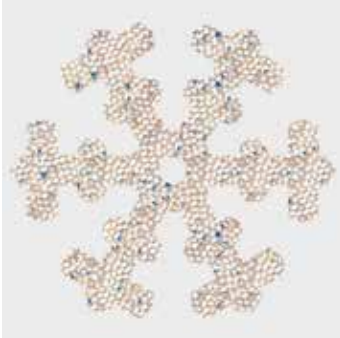

C	010-001AB		
S	~107x98		
M	9 PCS	40%	

72 027

02



C	012-001BBL		
S	~131x132		
M	8 PCS	30%	

72 028

02



C	010-001REDM		
S	~50x41		
M	42 PCS	80%	

72 029

02



C	012-001REDM		
S	~140x153		
M	4 PCS	25%	

72 030

02



C	010-001MLGLD		
S	~124x129		
M	6 PCS	30%	

72 031

02

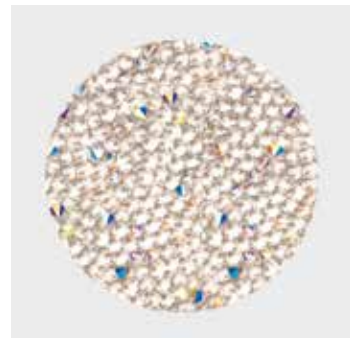

C	010-001AB		
S	~40x40		
M	48 PCS	90%	

Please note: All motifs are available in certain color/film variations (see colormatrix p. 491).

Synthetics Hotfix

Crystal Rocks

Standard Collection

72 032 Innovation Box



SS	010-001AB	
S	~30x30	
M	80 PCS	100%

Synthetics Hotfix

Crystal Rocks

Crystal Inspirations Collections



72 008 S/S 2011 **10**



C	001MLGLD	
S	~58x58	
M	42 PCS	70%

72 011 S/S 2011 **06**

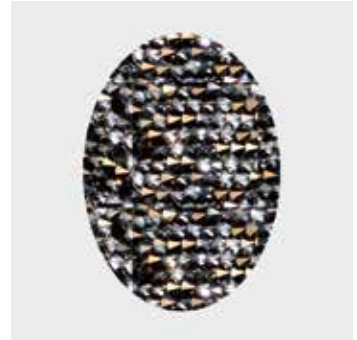

C	001MLGLD	
S	~26x37	
M	81 PCS	100%

72 013 S/S 2011 **14**

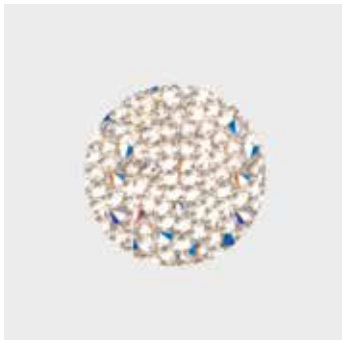

C	001AB	
S	~24x24	
M	120 PCS	100%

72 014 F/W 2011/12 **07**



C	001 SSHA	
S	~23x40	
M	110 PCS	100%

72 015 F/W 2011/12 **09**



C	001 GSHA	
S	~60x20	
M	75 PCS	60%

Please note: All motifs are available in certain color/film variations (see colormatrix p. 491).

72 016 S/S 2012 12



C	001 GSHA	
S	~60x60	
M	20 PCS	60%

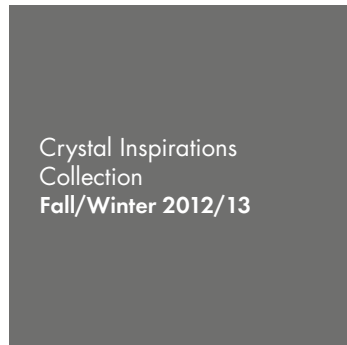

72 017 06



C	001 MLGLD	
S	~102x102	
M	9 PCS	40%



72 012 05



C	012-280	
S	~22x22	
M	143 PCS	100%



72 033 09

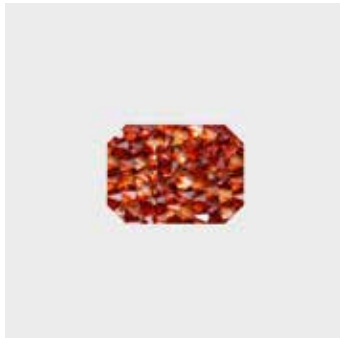

C	010-001REDM	
S	~18x13	
M	204 PCS	100%

Please note: All motifs are available in certain color/film variations (see colormatrix p. 491).

A special motif is a design created by the customer, which is different from the Crystal Rocks Standard Collection. This service opens up many customization possibilities and enables you to profit from Swarovski's longtime experience and design expertise. A range of customization options for existing motifs is available (see "Customization Possibilities" below). You may also submit sketches of a design that will suit your special needs – such as a brand image or an image to suit a particular sales campaign. This will then be made up according to your specifications using Computer Aided Design, which allows for easy adjustments according to your needs.

CUSTOMIZATION POSSIBILITIES FOR CRYSTAL ROCKS

- Min. size: 15x15 mm or effective surface of 2.25 cm²
- Max. size: 400x330 mm
- Min. Crystal Rocks surface: 9 mm
- Min. width of holes within motifs: 3 mm
- Min. size of the smallest element within a motif: 15x15 mm or effective surface of 2.25 cm²

Due to production issues, motifs with edges and angles of less than 90° need to be rounded off. Tolerance value = 3 mm.

ORDERING PROCESS

Send the request with a drawing you wish to order to your nearest Swarovski sales office. Make sure you include all measurements to the desired motif. Please also indicate which product group your special motif refers to (Crystal Rocks). You will then receive a quotation including your article number, minimum order quantity, price, and the line drawing of your special motif in PDF format. Please contact your Swarovski sales office again if any changes need to be made. Your special motif will be produced and delivered following your confirmation.

PLEASE NOTE

Please always submit your drawing of the desired motif to represent it in the actual size you require. A small sketch, when enlarged to the desired size, will have blurred lines that will make it difficult to correctly reinterpret. Pictures or drawings representing 100% size of the design or very good quality scans in JPG, BMP or DXF format will ensure that we have clear data to work with. These can also be sent via email or on a CD-ROM. If sending a sewing pattern, please include the whole pattern and not just cut outs. When the sketch is submitted as a hard copy by fax or e-mail, please include a scale legend (e.g. copy/scan with ruler next to the drawing). This will ensure that the desired size of the motif can be identified.

It is generally possible to draw motifs with a minimum gap of 10 mm between the outlines. However, due to the tolerance level of the crystals being applied onto carrier film, the final Crystal Rocks Motifs may generally differ from the sketches or prints in relation to the motifs' outline, especially with regards to spaces that are smaller than 10 mm. Therefore the motif, and by extension, the product itself, may be subject to individual variations with each reproduction. These variations are caused by technical production-related factors. As these variations are not deemed to be defects, warranty claims shall therefore not be entertained by Swarovski.

Special productions are generally offered to all our customers if feasibility is given and our General Terms and Conditions are applied. Please note that the simple order of a design does not grant exclusive production of this design to the customer.

If detailed information on the possible tolerances is needed (e.g. cavity production for a metal part), please contact Swarovski who will place an application request within our application database.

CRYSTAL FINE ROCKS

Fans of filigree design will love Crystal Fine Rocks. Small double pointed Chatons create a refined surface structure and a flexible texture that is thin and lightweight. Available in a wide selection, the washable Crystal Fine Rocks is set to become the star design element for all segments.

ARTICLE EXPLANATION

74 000 01



C	012-280
S	~97x100
M	9 PCS 40%

74 000	01	C	S	M	40 %
Article number	This motif is shown on flag number 1.	Color of crystal	Motif size in mm	Minimum order quantity in pieces (PCS)	Documentation size in %

ORDERING EXAMPLE & PRODUCT VARIETY EXPLANATION

74 000	010	001 GSHA
Article number	Color of film	Color of crystals
	010 Transparent 012 Black	001 AB Crystal Aurore Boreale 001 BBL Crystal Bermuda Blue 001 CAL Crystal Comet Argent Light 001 GSHA Crystal Golden Shadow 001 METSI Crystal Metallic Silver 001 MLGLD Crystal Metallic Light Gold 001 REDM Crystal Red Magma 001 SSHA Crystal Silver Shade 280 Jet M 100 M 101 M 102 M 103 M 104 M 106 M 109 Peach Gold

Please note: Crystal Comet Argent Light (001 CAL) is not suitable for swimwear because the effect 001 CAL has a high level of sensitivity to seawater, sweat or chlorine water.

AVAILABLE BASE MATERIALS AND CRYSTAL COLORS & EFFECTS

74 000 onwards

Color of Film

010 Transparent
012 Black

Color

Plain Color

● Jet (280)

Crystal Effects

Transparent Effects

● Crystal Aurore Boreale (001 AB)

● Crystal Bermuda Blue (001 BBL)

● Crystal Golden Shadow (001 GSHA)

● Crystal Red Magma (001 REDM)

● Crystal Silver Shade (001 SSHA)

Metallic Effects

● Crystal Comet Argent Light (001 CAL)

● Crystal Metallic Light Gold (001 MLGLD)

● Crystal Metallic Silver (001 METSI)

74 000 onwards

Color of Film

010 Transparent
012 Black

Multicolors

● Jet & Crystal Metallic Silver (M100)

● Crystal Bermuda Blue & Crystal Metallic Light Gold (M101)

● Crystal Bermuda Blue & Crystal Comet Argent Light (M102)

● Crystal Metallic Light Gold & Crystal Golden Shadow (M103)

● Crystal Metallic Light Gold & Crystal Red Magma (M104)

● Jet & Crystal Comet Argent Light (M106)

Peach Gold (M109)

● Light Peach & Crystal Metallic Light Gold

OVERVIEW OF AVAILABLE COLORS & EFFECTS



Synthetic Hotfix

Crystal Fine Rocks

Crystal Comet Argent Light (001 CAL)



010 Transparent

Crystal Metallic Light Gold (001 MLGLD)



010 Transparent

Crystal Metallic Silver (001 METSI)



010 Transparent

012 Black

Jet & Crystal Metallic Silver (M100)



012 Black

Crystal Bermuda Blue & Crystal Metallic Light Gold (M101)



012 Black

Crystal Bermuda Blue & Crystal Comet Argent Light (M102)

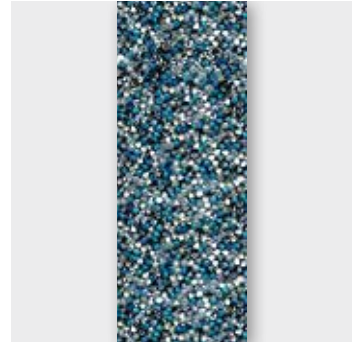

012 Black

Crystal Metallic Light Gold & Crystal Golden Shadow (M103)



010 Transparent

012 Black

Crystal Metallic Light Gold & Crystal Red Magma (M104)



010 Transparent

012 Black

Jet & Crystal Comet Argent Light (M106)



012 Black

Peach Gold (M109)



010 Transparent

012 Black

Synthetics Hotfix

Crystal Fine Rocks

Standard Collection



74 000 01



C	012-280		
S	~97x100		
M	9 PCS		40%

74 001 01



C	012-001SSHA		
S	~130x130		
M	6 PCS		30%

74 002 01



C	010-001CAL		
S	~92x121		
M	12 PCS		30%

74 003 01/Innovation Box



C	010-001GSHA		
S	~24x24		
M	120 PCS		100%

74 004



C	010-001AB		
S	~68x68		
M	20 PCS		60%

74 005



C	010-001REDM		
S	~66x66		
M	20 PCS		60%

74 006



C	010-001MLGLD		
S	~115x114		
M	9 PCS		35%

74 007



C	010-001GSHA		
S	~65x92		
M	20 PCS		40%

74 008 01



C	010-001MLGLD		
S	~52x54		
M	35 PCS		70%

74 009 01



C	010-001SSHA		
S	~65x28		
M	64 PCS		60%

74 010 01



C	010-001GSHA		
S	~31x78		
M	48 PCS		50%

Please note: All motifs are available in certain color/film variations (see colormatrix p. 499).

Synthetics Hotfix

Crystal Fine Rocks

Standard Collection

74 011 01



C	010-001AB
S	~23x22
M	154 PCS
	100%

74 012 01



C	010-001REDM
S	~40x33
M	64 PCS
	90%

74 013 01



C	012-001BBL
S	~90x57
M	22 PCS
	45%

74 014



C	012-001AB
S	~134x38
M	18 PCS
	30%

74 015 01



C	012-001REDM
S	~112x104
M	9 PCS
	35%

74 023 Innovation Box



C	010-001AB
S	~27x19
M	204 PCS
	100%

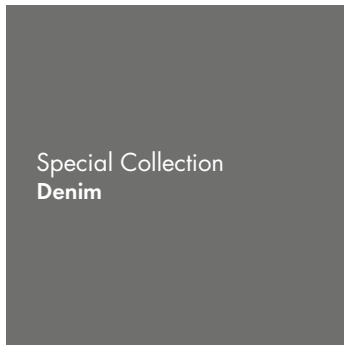

Special Collection
Denim

74 016

03



C	010-001MLGLD	
S	~195x12	
M	32 PCS	100%



Special Collection
Lingerie

74 018

07



C	012-280	
S	~134x69	
M	18 PCS	30%



74 017 07



C	010-001MLGLD
S	~195x12
M	32 PCS 22%

74 019 10

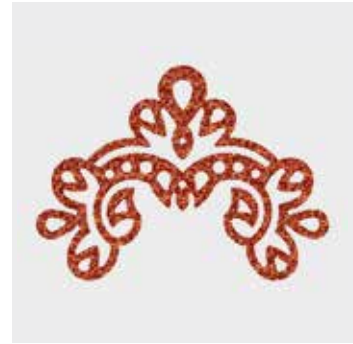

C	010-001MLGLD
S	~195x12
M	32 PCS 25%

74 020 09



C	010-001MLGLD
S	~104x48
M	21 PCS 40%

74 021 03



C	010-001METSJ
S	~55x40
M	40 PCS 70%

74 022 03



C	012-M100
S	~55x40
M	40 PCS 70%

A special motif is a design created by the customer, which is different from the Crystal Fine Rocks Standard Collection. This service opens up many customization possibilities and enables you to profit from Swarovski's longtime experience and design expertise. A range of customization options for existing motifs is available (see "Customization Possibilities" below). You may also submit sketches of a design that will suit your special needs, such as a brand image or an image to suit a particular sales campaign. This will then be made up according to your specifications using Computer Aided Design, which allows for easy adjustments according to your needs.

CUSTOMIZATION POSSIBILITIES FOR CRYSTAL FINE ROCKS

- Min. size: 15x15 mm or effective surface of 2.25 cm²
- Max. size: 400x330 mm
- Min. Crystal Fine Rocks surface: 4 mm
- Min. width of holes within motifs: 3 mm
- Min. size of the smallest element within a motif: 15x15 mm or effective surface of 2.25 cm²

ORDERING PROCESS

Please send a request with the drawing you wish to order to your nearest Swarovski sales office. Make sure you include all measurements of the desired motif. Please also indicate which product group your special motif refers to (Crystal Fine Rocks). You will then receive a quotation including your article number, minimum order quantity, price, and the line drawing of your special motif in PDF format. Please contact your Swarovski sales office again if any changes need to be made. Your special motif will be produced and delivered following your confirmation.

PLEASE NOTE

Please always submit your drawing of the desired motif to represent it in the actual size you require. A small sketch, when enlarged to the desired size, will have blurred lines which will make it difficult to correctly reinterpret. Pictures or drawings representing 100% size of the design or very good quality scans in JPG, BMP or DXF format ensure that we have clear data to work with. These can also be submitted as a hard copy by fax or e-mail. Please include a scale (e.g. copy/scan with ruler next to the drawing). This will ensure that the desired size of the motif can be correctly identified. Generally, it is possible to draw motifs with a minimum gap of 10 mm between the outlines. However, due to the tolerance level of the crystals being applied onto carrier film, the final Crystal Fine Rocks Motifs may differ from the sketches or prints in relation to the motifs' outline, especially with regards to spaces that are smaller than 10 mm. Therefore, the motif, and by extension, the product itself, may be subject to individual variations with each reproduction. These variations are caused by technical production-related factors. As these variations are not deemed to be defects, Swarovski is not in a position to entertain any subsequent warranty claims.

Special productions are generally offered to all our customers if feasibility is given and our General Terms and Conditions are applied. Please note that the simple order of a design does not grant exclusive production of this design to the customer.

If detailed information on the possible tolerances is needed (e.g. cavity production for a metal part), please contact Swarovski who will place an application request within our application database.

ARTICLE EXPLANATION

62 000

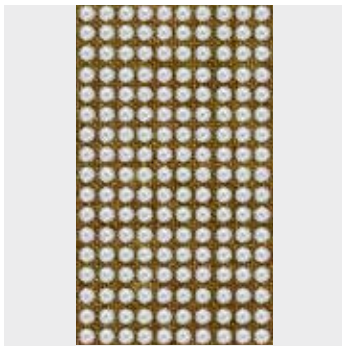

R	001-012; 057
SS	SS 6 (2038)
M	10 M* 100%

62 000	R	SS	M	100%
Article number	This article is available in 1-12 and 57 rows.	Stone size	Minimum order quantity in meters (M)	Documentation size in %

ORDERING EXAMPLE & PRODUCT VARIETY EXPLANATION

62 000	010	F080	001	NOHF
Article number	3-digit code for number of rows	Type and color of base material	Color of crystals	Hotfix Technology
		F Fabric S Synthetic	Please see the respective product matrix for all available code references.	HF With Hotfix glue NOHF Without Hotfix glue**
		010 Transparent 012 Black 080 Antique Gold 081 Gold 082 Silver 083 Antique Silver		

* Please note: Bandings can be divided.

** All Crystaltext articles are available as Hotfix or No Hotfix version, except versions S010 Synthetic Transparent and S012 Synthetic Black (both only as Hotfix).

AVAILABLE BASE MATERIAL & STONE CONFIGURATIONS

Crystaltex Bandings are available in six different base materials. Please see the respective product matrix for all available options.



F082 Fabric Silver



F083 Fabric Antique Silver



F081 Fabric Gold



F080 Fabric Antique Gold

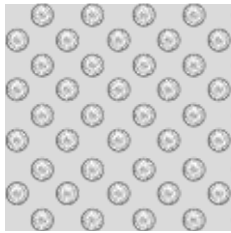

S010 Synthetic Transparent

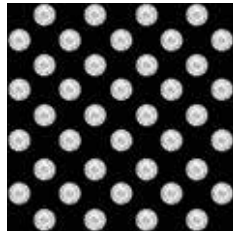

S012 Synthetic Black

62 000

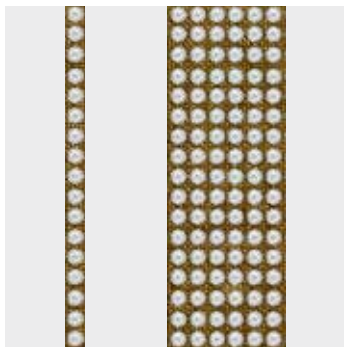

R	001-012; 057
SS	SS 6 (2038)
M	10 M* 100%

62 010

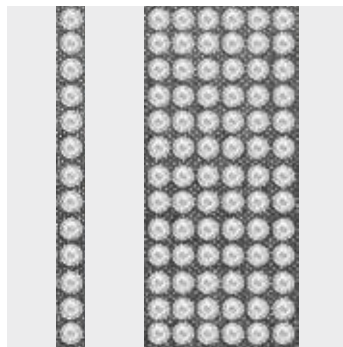

R	001-012; 022; 044
SS	SS 10 (2038)
M	10 M* 100%

62 011



R	001-07; 044
SS	SS 10 (2038)
M	10 M* 100%

62 020

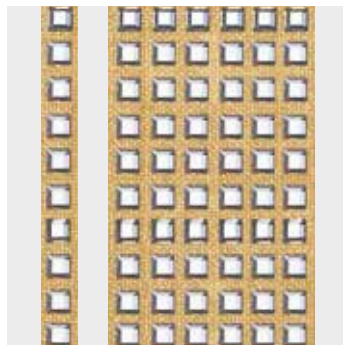

R	001-006; 033
SS	3 mm (2400)
M	10 M* 100%

* Please note: Bandings can be divided.

	Stone Size			Base Material					
	SS 6	SS 10	3 mm	F080 Fabric Antique Gold	F081 Fabric Gold	F082 Fabric Silver	F083 Fabric Antique Silver	S010 Synthetic Transparent*	S012 Synthetic Black*
<div style="display: flex; justify-content: space-between;"> <div style="width: 20%;"> <p>62 000*</p> <p>62 010*</p> <p>62 011*</p> <p>62 020*</p> </div> <div style="width: 80%;"></div> </div>									
Crystal									
Crystal F (001)	■	■	■	■	■	■	■	■	■
Colors									
Plain Colors									
Amethyst F (204)	■	■		■	■	■	■	■	■
Aquamarine F (202)	■	■		■	■	■	■	■	■
Black Diamond F (215)	■	■		■	■	■	■	■	■
Fuchsia F (502)	■	■		■	■	■	■	■	■
Jet F (280)	■	■	■	■	■	■	■	■	■
Light Rose F (223)	■	■		■	■	■	■	■	■
Light Siam F (227)	■	■		■	■	■	■	■	■
Peridot F (214)	■	■		■	■	■	■	■	■
Sapphire F (206)	■	■		■	■	■	■	■	■
Silk F (391)	■	■		■	■	■	■	■	■
Smoked Topaz F (220)	■	■		■	■	■	■	■	■
Crystal Effects									
Transparent Effects									
Crystal AB F (001 AB)	■	■	■	■	■	■	■	■	■
Crystal Golden Shadow F (001 GSHA)	■	■		■	■	■	■	■	■
Crystal Luminous Green F (001 LUMG)	■	■		■	■	■	■	■	■
Crystal Silver Shade F (001 SSHA)	■	■		■	■	■	■	■	■
Metallic Effects									
Crystal Dorado F (001 DOR)	■	■		■	■	■	■	■	■
Crystal Iridescent Green F (001 IRIG)	■	■		■	■	■	■	■	■
Crystal Rose Gold F (001 ROGL)	■	■		■	■	■	■	■	■
Color Effects									
Metallic Effects									
Jet Hematite F (280 HEM)	■	■	■	■	■	■	■	■	■

13 Synthetics Hotfix

* All Crystaltex articles are available as Hotfix or No Hotfix version, except versions S010 Synthetic Transparent and S012 Synthetic Black (both only as Hotfix).

ARTICLE EXPLANATION

66 043 F/W 2010/11 12

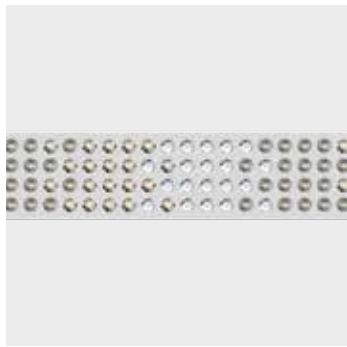

C	S010-001SSHA/001/215
E	S6/S6/S6
S	~39x10
M	32.810 M (840 PCS) 100%

66 043	12	C	E	S	M	100%
Article Number	This motif is shown on flag number 12.	Color assortment Color of base material (S010) is separated from crystal colors with a hyphen. Color code 1 (001 SSHA) corresponds with element 1; color code 2 (001) corresponds with element 2 etc.	Elements Crystaltex Bandings Motifs are available in stone sizes SS 6 and SS 10 in close stone setting.	Motif size in mm	Minimum Order Quantity in meters (M); pieces (PCS)	Documentation size in %

ORDERING EXAMPLE & PRODUCT VARIETY EXPLANATION

66 043	S010	001 SSHA	001	215	HF
Article Number	Type and color of base material	Crystal color corresponding to element 1; color of most frequently used element in the motif	Crystal color corresponding to element 2; color of second most frequently used element in the motif	Crystal color corresponding to element 3; color of third most frequently used element in the motif	Hotfix Technology HF Hotfix NOHF No Hotfix
	F Fabric S Synthetic				
	010 Transparent 012 Black 080 Antique Gold 081 Gold 082 Silver 083 Antique Silver	Please see the respective product matrix for all available code references.			

The Minimum Order Quantity (MOQ) for Standard Motifs is 1 packing unit (approx. 5 meters). Samples can be ordered below 1 packing unit. If the Standard Motifs are modified (color changes), please refer to the detailed MOQ information at the end of this chapter. This product must be ordered in meters.

66 000* to 66 043*		Stone Size	SS 6	SS 10	Base Material	F080 Fabric Antique Gold	F081 Fabric Gold	F082 Fabric Silver	F083 Fabric Antique Silver	S010 Synthetic Transparent *	S012 Synthetic Black *
Crystal											
Crystal F (001)			■	■		■	■	■	■	■	■
Colors											
Plain Colors											
Amethyst F (204)			■	■		■	■	■	■	■	■
Aquamarine F (202)			■	■		■	■	■	■	■	■
Black Diamond F (215)			■	■		■	■	■	■	■	■
Fuchsia F (502)			■	■		■	■	■	■	■	■
Jet F (280)			■	■		■	■	■	■	■	■
Light Rose F (223)			■	■		■	■	■	■	■	■
Light Siam F (227)			■	■		■	■	■	■	■	■
Peridot F (214)			■	■		■	■	■	■	■	■
Sapphire F (206)			■	■		■	■	■	■	■	■
Silk F (391)			■	■		■	■	■	■	■	■
Smoked Topaz F (220)			■	■		■	■	■	■	■	■
Crystal Effects											
Transparent Effects											
Crystal AB F (001 AB)			■	■		■	■	■	■	■	■
Crystal Golden Shadow F (001 GSHA)			■	■		■	■	■	■	■	■
Crystal Luminous Green F (001 LUMG)			■	■		■	■	■	■	■	■
Crystal Silver Shade F (001 SSHA)			■	■		■	■	■	■	■	■
Metallic Effects											
Crystal Dorado F (001 DOR)			■	■		■	■	■	■	■	■
Crystal Iridescent Green F (001 IRIG)			■	■		■	■	■	■	■	■
Crystal Rose Gold F (001 ROGL)			■	■		■	■	■	■	■	■
Color Effects											
Metallic Effects											
Jet Hematite F (280 HEM)			■	■		■	■	■	■	■	■

* All Crystaltext articles are available as Hotfix or No Hotfix version, except versions S010 Synthetic Transparent and S012 Synthetic Black (both only as Hotfix).



66 001 **02**

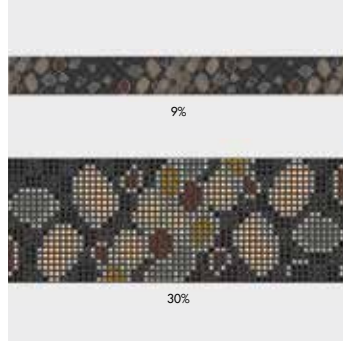

C	I012-280HEM/280/001SSHA/ 001GSHA/220/215/001DOR
E	S6/S6/S6/S6/S6/S6
S	~250X55
M	5 M (20 PCS)

66 003 **02**

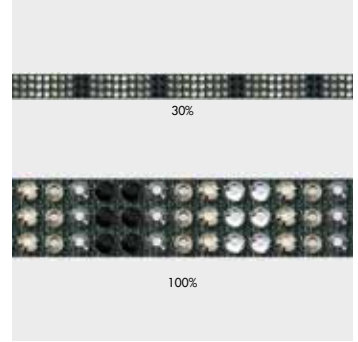

C	F083-001/001SSHA/215/280HEM/280
E	S10CT/S10CT/S10CT/S10CT/S10CT
S	~477x10
M	4.773 M (10 PCS)

66 014 **02**



C	F083-001/001SSHA/215/280HEM/280
E	S10CT/S10CT/S10CT/S10CT/S10CT
S	~68x10
M	4.773 M (70 PCS) 60%



66 043 F/W 2010/11 **12**



C	S010-001SSHA/001/215
E	S6/S6/S6
S	~39x10
M	32.810 M (840 PCS) 100%

PRODUCT DETAILS

Article Number	Standard Motifs (as shown)				Modified Standard Motifs (change of color)			
	Packing Unit = MOQ		MOQ for Samples		MOQ		MOQ for Samples	
	in meters	in pieces	in meters	in pieces	in meters	in pieces	in meters	in pieces
66 001	5.000	20	0.250	1	5.000	20	0.500	2
66 003	4.773	10	0.477	1	33.408	70	6.682	14
66 014	4.773	70	0.068	1	33.408	490	2.864	42
66 043	4.687	120	0.039	1	32.810	840	3.281	84

The MOQ for Standard Motifs is 1 packing unit (approx. 5 meters). Samples can be ordered below 1 packing unit. If the Standard Motifs are modified (color changes) please refer to the detailed MOQ information in the table above. This product must be ordered in meters. All Standard Crystaltex Bandings Motifs are also available as it-version.

ARTICLE EXPLANATION

The extended assortment of colors can be combined with six different base materials and opens up a multitude of options for individual designs. Up to eight different colors can be incorporated in a motif. All Crystaltex Motifs are also available as it-version.

65 322

03



C	S012-001IRIG/001AB/202
E	S6/S6/S6
S	~57x49
M	18PCS
	70%

65 322	03	C	E	S	M	70%
Article number	This product is shown on flag number 3.	Color assortment	Elements	Motif size in mm	Minimum order quantity in pieces (PCS)	Documentation size in %
		Color of base material (S012) is seperated from crystal colors with a hyphen. Color code 1 (001IRIG) corresponds with element 1; color code 2 (001AB) corresponds with element 2 etc.	Crystaltex Motifs are available in stone sizes SS 6 and SS 10.			

ORDERING EXAMPLE & PRODUCT VARIETY EXPLANATION



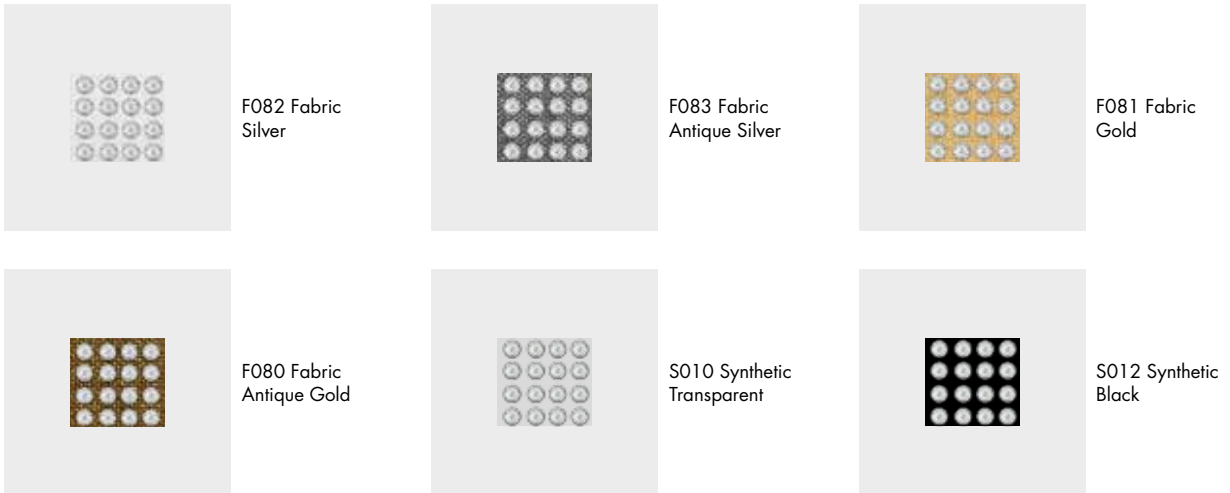

65 322	S012	001IRIG	001AB	202
Article number	Type and color of base material	Crystal color corresponding to element 1; color of most frequently used element in the motif	Crystal color corresponding to element 2; color of second most frequently used element in the motif	Crystal color corresponding to element 3; color of third most frequently used element in the motif
	F Fabric S Synthetic			
	010 Transparent 012 Black 080 Antique Gold 081 Gold 082 Silver 083 Antique Silver	Please see the respective product matrix for all available code references.		

AVAILABLE BASE MATERIAL COLORS

Crystaltex Motifs are available in four different fabric and two different synthetic base material colors. Please see the respective product matrix for all available options.



Crystaltex Motifs 65 000 onwards		Stone Size	SS 6	SS 10	Base Material	F080 Fabric Antique Gold	F081 Fabric Gold	F082 Fabric Silver	F083 Fabric Antique Silver	S010 Synthetic Transparent	S012 Synthetic Black
Crystal											
Crystal F (001)											
Colors											
Plain Colors											
Amethyst F (204)											
Aquamarine F (202)											
Black Diamond F (215)											
Fuchsia F (502)											
Jet F (280)											
Light Rose F (223)											
Light Siam F (227)											
Peridot F (214)											
Sapphire F (206)											
Silk F (391)											
Smoked Topaz F (220)											
Crystal Effects											
Transparent Effects											
Crystal AB F (001 AB)											
Crystal Golden Shadow F (001 GSHA)											
Crystal Luminous Green F (001 LUMG)											
Crystal Silver Shade F (001 SSHA)											

Crystaltex Motifs 65 000 onwards		Stone Size	SS 6	SS 10	Base Material	F080 Fabric Antique Gold	F081 Fabric Gold	F082 Fabric Silver	F083 Fabric Antique Silver	S010 Synthetic Transparent	S012 Synthetic Black
Metallic Effects											
	Crystal Dorado F (001 DOR)		■	■	■	■	■	■	■	■	■
	Crystal Iridescent Green F (001 IRIG)		■	■	■	■	■	■	■	■	■
	Crystal Rose Gold F (001 ROGL)		■	■	■	■	■	■	■	■	■
Color Effects											
Metallic Effects											
	Jet Hematite F (280 HEM)		■	■	■	■	■	■	■	■	■

Synthetics Hotfix

Crystaltex Motifs

Standard Collection



Standard Collection

65 011

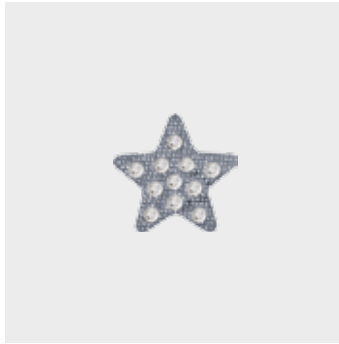

C	F083-001
SS	SS 6
S	~ Ø 17
M	100 PCS
	100%

65 291

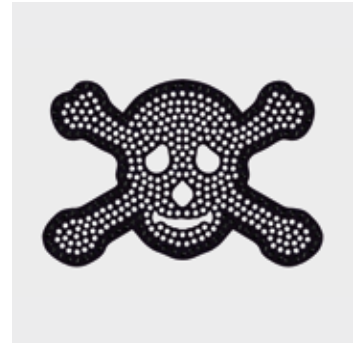

C	S012-001/280
E	S6/S6
S	~93x62
M	6 PCS
	40%

65 295



C	F083-001DOR/391/001AB
E	S6/S6/S6
S	~81x84
M	6 PCS
	50%

65 316

03



C	S010-204
E	S6
S	~78x28
M	24 PCS
	50%

65 317

03



C	S012-001SSHA/001/215
E	S6/S6/S6
S	~49x102
M	15 PCS
	35%

65 318

03



C	S010-223/001
E	S6/S6
S	~71x34
M	21 PCS
	60%

65 319

03



C	S012-001/001AB
E	S6/S6
S	~51x56
M	18 PCS
	60%

65 320

03



C	S010-227
E	S6
S	~70x22
M	24 PCS
	60%

65 321

03

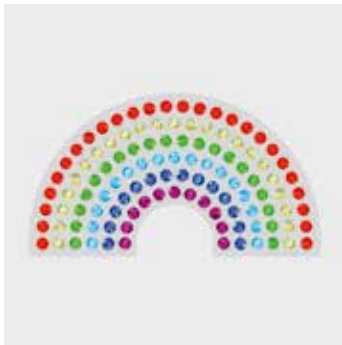

C	S010-227/001LUMG/214/202/206/502
E	S10/S10/S10/S10/S10/S10
S	~64x36
M	18 PCS
	60%

65 322

03



C	S012-001IRIG/001AB/202
E	S6/S6/S6
S	~57x49
M	18PCS
	70%

65 323

03

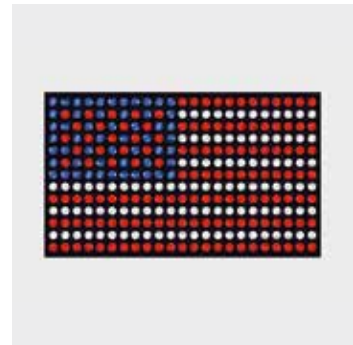

C	S012-227/001/206
E	S6/S6/S6
S	~61x36
M	18 PCS
	60%

Synthetics Hotfix

Crystaltex Motifs

Standard Collection

65 324 03

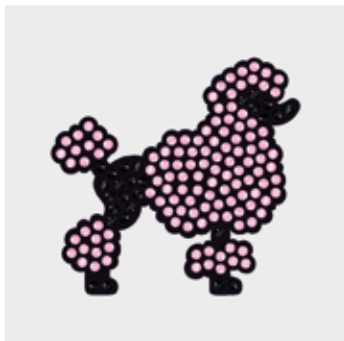

C S012-223/280
E S6/S6
S ~47x45
M 18 PCS 70%

65 325 03

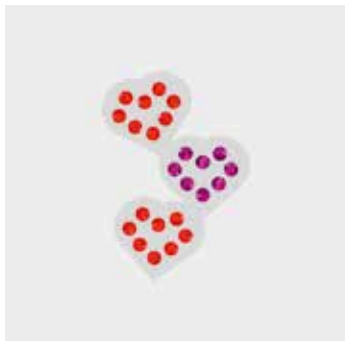

C S010-227/502
E S6/S6
S ~20x28
M 90 PCS 100%

65 326 03



C F081-001
E S6
S ~39x17
M 54 PCS 100%

65 327 03



C F081-001ROGL/001DOR
E S6/S6
S ~34x43
M 36 PCS 100%

65 328 03



C S012-001AB
E S10
S ~44x31
M 36 PCS 80%

65 329 03



C S012-280
E S6
S ~18x39
M 72 PCS 100%

65 330 03



C S010-223/391
E S6/S6
S ~31x42
M 36 PCS 100%

65 331 03



C F081-001DOR
E S6
S ~19x50
M 54 PCS 80%

65 332 03



C S012-001LUMG/214/227/280/001/
280HEM
E S6/S6/S6/S6/S6
S ~42x42
M 24 PCS 80%

65 333 03



C S010-001GSHA/223/391/001LUMG
E S6/S6/S6/S6
S ~29x46
M 36 PCS 80%

65 334 03



C S010-001/001GSHA/001DOR/214
E S6/S6/S6/S6
S ~34x46
M 33 PCS 80%

65 335 03



C S012-001ROGL/001DOR/391/001AB
E S6/S6/S6/S6
S ~84x84
M 9 PCS 50%

Synthetics Hotfix

Crystaltex Motifs

Standard Collection

65 336 03



C	S012-001/280HEM
E	S10/S10
S	~115x24
M	18 PCS
	35%

65 337 03



C	S010-001AB
E	S10
S	~68x60
M	12 PCS
	60%

Synthetics Hotfix

Crystaltex Motifs

Crystal Inspirations Collection

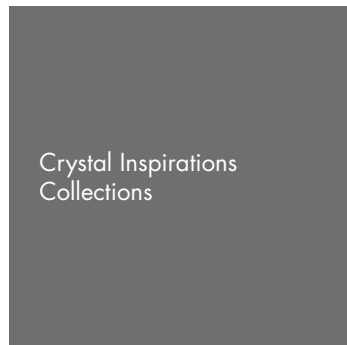

65 282 F/W 2010/11 04



C	S012-227
E	S6
S	~76x50
M	12 PCS
	50%

65 307 S/S 2012 06



C	F082-001SSHA/215
E	S6/S6
S	~142x39
M	9 PCS
	29%

ARTICLE EXPLANATION

Small XILLION Chatons turn this product into an exciting, luxurious and unique statement in the fashion world. Crystaltext Chaton Bandings offer a wide range of design possibilities for the jewelry, fashion accessories, and interior segments.

62 030

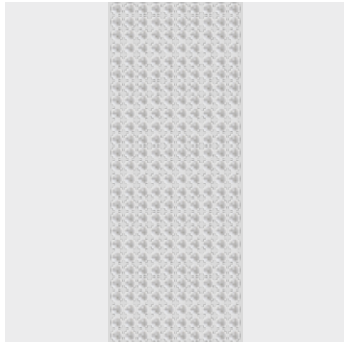

R	002-010, 088
SS	PP 9 (1028)
M	5 M* 100%

62 030	R	SS	M	100 %
Article number	This article is available in 2-10 and in 88 rows.	Stone size	Minimum order quantity in metre (M)	Documentation size in %

ORDERING EXAMPLE & PRODUCT VARIETY EXPLANATION

62 030	010	S010	001
Article number	3-digit code for number of rows	Type and color of base material S Synthetic 010 Transparent 012 Black	Color of crystals Please see the respective product matrix for all available code references.

* Please note: Bandings can be divided.

62 030

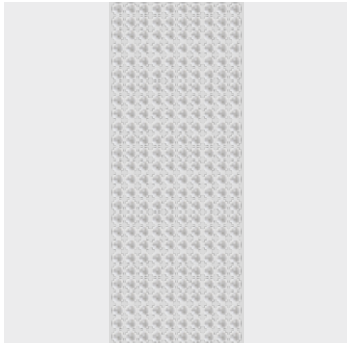

Rows	2 rows	3 rows	4 rows	5 rows	6 rows	7 rows	8 rows	9 rows	10 rows	88 rows	Color of Film	S010 Synthetic Transparent	S012 Synthetic Black
------	--------	--------	--------	--------	--------	--------	--------	--------	---------	---------	---------------	----------------------------	----------------------

Crystal

Crystal F (001)

Colors

Plain Colors

Aquamarine F (202)

Black Diamond F (215)

Dark Indigo F (288)

Fuchsia F (502)

Indicolite F (379)

Jet F (280)

Khaki F (550)

Light Siam F (227)

Rose F (209)

Smoked Topaz F (220)

Tanzanite F (539)

Crystal Effects

Transparent Effects

Crystal AB F (001 AB)

Crystal Golden Shadow F (001 GSHA)

Crystal Silver Shade F (001 SSHA)

Metallic Effects

Crystal Dorado F (001 DOR)

Crystal Iridescent Green F (001 IRIG)

Color Effects

Metallic Effects

Jet Hematite F (280 HEM)

13 Synthetics Hotfix

62 031 (Honeycomb)



	3 rows	4 rows	5 rows	6 rows	10 rows	17 rows	S010 Synthetic Transparent	S012 Synthetic Black
Rows								
Crystal								
Crystal F (001)	■	■	■	■	■	■	■	■
Colors								
Plain Colors								
Aquamarine F (202)	■	■	■	■	■	■	■	■
Black Diamond F (215)	■	■	■	■	■	■	■	■
Jet F (280)	■	■	■	■	■	■	■	■
Dark Indigo F (288)	■	■	■	■	■	■	■	■
Crystal Effects								
Transparent Effects								
Crystal AB F (001 AB)	■	■	■	■	■	■	■	■
Crystal Golden Shadow F (001 GSHA)	■	■	■	■	■	■	■	■
Crystal Silver Shade F (001 SSHA)	■	■	■	■	■	■	■	■
Metallic Effects								
Crystal Dorado F (001 DOR)	■	■	■	■	■	■	■	■
Crystal Iridescent Green F (001 IRIG)	■	■	■	■	■	■	■	■
Color Effects								
Metallic Effects								
Jet Hematite F (280 HEM)	■	■	■	■	■	■	■	■

ARTICLE EXPLANATION

Crystaltex Chaton is also available as Standard Motifs and Special Motifs (customized laser-cut-motifs). Up to four colors can be combined within one motif opening up a multitude of options for individual designs. All Crystaltex Chaton Standard Motifs are also available as it-version.

85 119 F/W 2012/13 **02/04**





















C	S010-001GSHA/001AB
E	PP9/PP9
S	~104x101
M	3 PCS 40%

85 119	02/04	C	E	S	M	40%
Article number	This product is shown on flag number 2 and 4.	Color assortment Color of base material (S010) is seperated from crystal colors with a hyphen. Color code 1 (001 GSHA) corresponds with element 1; color code 2 (001 AB) corresponds with element 2 etc.	Elements Crystaltex Motifs are available in stone sizes PP 9.	Motif size in mm	Minimum order quantity in pieces (PCS)	Documentation size in %

ORDERING EXAMPLE & PRODUCT VARIETY EXPLANATION

85 119	S010	001 GSHA	001 AB
Article number	Type and color of base material S Synthetic 010 Transparent 012 Black	Crystal color corresponding to element 1; color of most frequently used element in the motif Please see the respective product matrix for all available code references.	Crystal color corresponding to element 2; color of second most frequently used element in the motif

Crystaltex Chaton Motifs 85 100 onwards		Color of Film	
		S010 Synthetic Transparent	S012 Synthetic Black
Crystal			
 Crystal F (001)	■	■	■
Colors			
Plain Colors			
 Aquamarine F (202)	■	■	■
 Black Diamond F (215)	■	■	■
 Dark Indigo F (288)	■	■	■
 Fuchsia F (502)	■	■	■
 Indicolite F (379)	■	■	■
 Jet F (280)	■	■	■
 Khaki F (550)	■	■	■
 Light Siam F (227)	■	■	■
 Rose F (209)	■	■	■
 Smoked Topaz F (220)	■	■	■
 Tanzanite F (539)	■	■	■
Crystal Effects			
Transparent Effects			
 Crystal AB F (001 AB)	■	■	■
 Crystal Golden Shadow F (001 GSHA)	■	■	■
 Crystal Silver Shade F (001 SSHA)	■	■	■
Metallic Effects			
 Crystal Dorado F (001 DOR)	■	■	■
 Crystal Iridescent Green F (001 IRIG)	■	■	■
Color Effects			
Metallic Effects			
 Jet Hematite F (280 HEM)	■	■	■

Synthetics Hotfix

Crystaltex Chaton Motifs

Standard Collection



Standard Collection

85 102



C	I010-001
E	PP9
S	~23x14
M	135 PCS
	100%

85 103

02



C	S010-001AB/001
E	PP9/PP9
S	~33x32
M	45 PCS
	100%

85 104

02



C	S010-209
E	PP9
S	~94x67
M	9 PCS
	40%

85 105

02



C	S010-215/280/001
E	PP9/PP9/PP9
S	~40x40
M	27 PCS
	100%

85 106

02

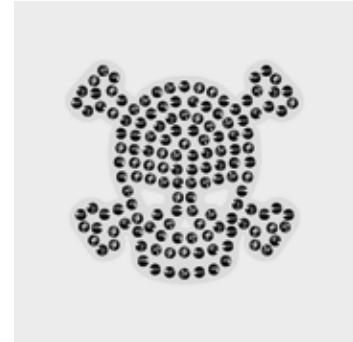

C	S010-280HEM
E	PP9
S	~32x30
M	45 PCS
	100%

85 108

02



C	S010-502/227
E	PP9/PP9
S	~31x30
M	54 PCS
	100%

85 111

02

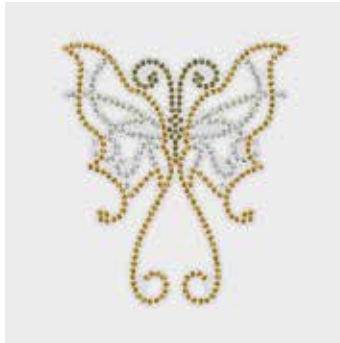

C	S010-001DOR/001SSHA/550
E	PP9/PP9/PP9
S	~61x71
M	9 PCS
	50%

85 112

02



C	S010-001GSHA/001DOR/001SSHA
E	PP9/PP9/PP9
S	~77x75
M	12 PCS
	45%

85 113

02



C	S010-001GSHA
E	PP9
S	~30x26
M	60 PCS
	100%

85 114

02



C	S010-379/001DOR/550
E	PP9/PP9/PP9
S	~84x55
M	9 PCS
	50%

85 116

02



C	S010-001GSHA/001SSHA/001
E	PP9/PP9/PP9
S	~59x54
M	15 PCS
	70%

Synthetics Hotfix

Crystaltex Chaton Motifs

Standard Collection

85 117 **02**

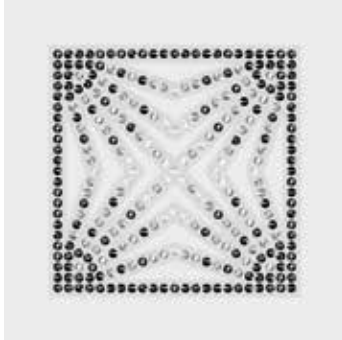

C	S010-280HEM/001SSHA/001
E	PP9/PP9/PP9
S	~42x42
M	18 PCS
	80%

85 118 **02**

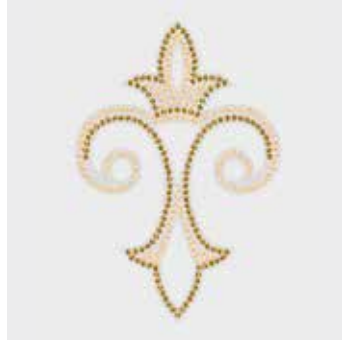

C	S010-001GSHA/001DOR
E	PP9/PP9
S	~56x81
M	12 PCS
	50%

85 119 **02**



C	S010-001GSHA/001AB
E	PP9/PP9
S	~104x101
M	3 PCS
	40%

85 121 **02**

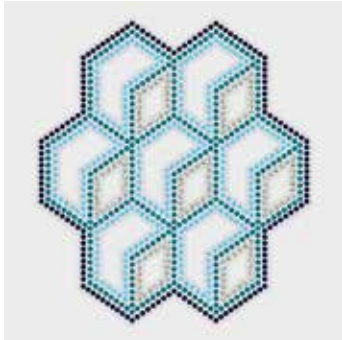

C	S010-379/202/288/001SSHA
E	PP9/PP9/PP9/PP9
S	~81x91
M	6 PCS
	45%

85 122 **02**

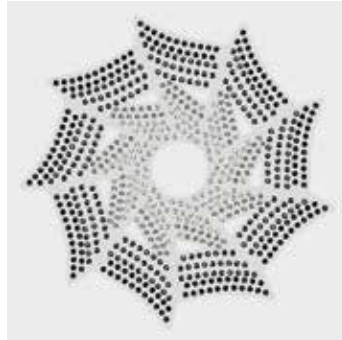

C	S010-280HEM/280/001SSHA/215
E	PP9/PP9/PP9/PP9
S	~83x83
M	6 PCS
	50%

85 127 **02**



C	S010-001AB/001
E	PP9/PP9
S	~60x46
M	18 PCS
	70%

85 134



C	S010-001GSHA/001DOR/220
E	PP9/PP9/PP9
S	~38x50
M	27 PCS
	80%

85 136 **02**



C	S010-220/001DOR/001GSHA
E	PP9/PP9/PP9
S	~77x75
M	12 PCS
	50%

85 137



C	S010-001
E	PP9
S	~24x23
M	99 PCS
	100%



85 100 07



C	S010-001DOR/550/001GSHA
E	PP9/PP9/PP9
S	~132x31
M	9 PCS 30%

85 101 11

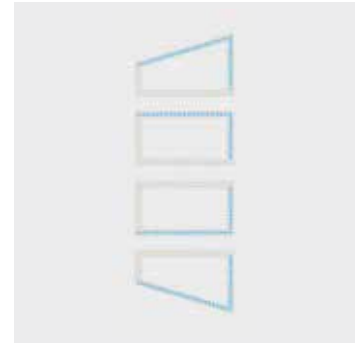

C	S010-202/001AB
E	PP9/PP9
S	~43x124
M	6 PCS 30%

85 135 03



C	S010-379/288/215/280HEM
E	PP9/PP9/PP9/PP9
S	~149x31
M	9 PCS 27%

A special motif is any individual design created by the customer, which is different from the Crystaltext Motifs Standard or Crystal Inspirations Collections. This service opens up many customization possibilities and enables you to profit from Swarovski's longtime experience and design expertise. A range of customization options for existing motifs is available (see "Customization Possibilities" below). You may also submit sketches of a design that will suit your special needs – such as a brand image or an image to suit a particular sales campaign. This will then be made up according to your specifications using Computer Aided Design, which allows for easy adjustments according to your needs. All Standard Crystaltext Motifs are also available as it-version and vice versa.

CUSTOMIZATION POSSIBILITIES FOR CRYSTALTEXT MOTIFS

Min. size: 12x12 mm (4x4 stones)

Max. size: 122x157 mm

Distance between the Flat Backs SS 10 (from stone centre to stone centre):

- Max. 4.8 mm
- Min. 3.4 mm

Distance between the Flat Backs SS 6 (from stone centre to stone centre):

- Max. 3.7 mm
- Min. 2.4 mm

Up to eight colors are possible for Crystaltext Motifs using either SS 6 or SS 10 stones (mix of stone sizes is not possible).

CUSTOMIZATION POSSIBILITIES FOR CRYSTALTEXT CHATON MOTIFS

Min. size: 10x10 mm

Max. size: 122x157 mm

Distance between Chatons art. 1028 PP 9 (from stone center to stone center): min. 1.70 mm – max. 4.5 mm

Up to four colors are possible for Crystaltext and Crystaltext-it Chaton Motifs using stone size PP 9.

ORDERING PROCESS

Send the request with a drawing you wish to order to your nearest Swarovski sales office. Make sure you include all measurements to the desired motif. Please also indicate which product group your special motif refers to. You will then receive a quotation including your article number, minimum order quantity (MOQ), price, and the line drawing of your special motif in PDF format. Please contact your Swarovski sales office again if any changes need to be made. Your special motif will be produced and delivered following your confirmation.

PLEASE NOTE

Please always submit your drawing of the desired motif to represent it in the actual size you require. A small sketch, when enlarged to the desired size, will have blurred lines that will make it difficult to correctly reinterpret. Pictures or drawings representing 100% size of the design or very good quality scans in JPG, BMP or DXF format will ensure that we have clear data to work with. These can also be sent via email or on a CD-ROM. If sending a sewing pattern, please include the whole pattern and not just cut outs. When the sketch is submitted as a hard copy by fax or e-mail, please include a scale legend (e.g. copy/scan with ruler next to the drawing). This will ensure that the desired size of the motif can be identified.

Special productions are generally offered to all our customers if feasibility is given and our General Terms and Conditions are applied.

Please note that the simple order of a design does not grant exclusive production of this design to the customer.

If detailed information on the possible tolerances is needed (e.g. cavity production for a metal part), please contact Swarovski who will place an application request within our application database.

Plastic Trimmings

Plastic Trimmings are plastic carrier materials with integrated crystals. These multi-functional products can either be hand- or machine-sewn or glued onto various surfaces. The range of bandings not only offers a color selection of chatons, but also a variety of casing colors. Plastic components, like Mini Rondelles enable many different designs in all segments.

ARTICLE EXPLANATION

50 004

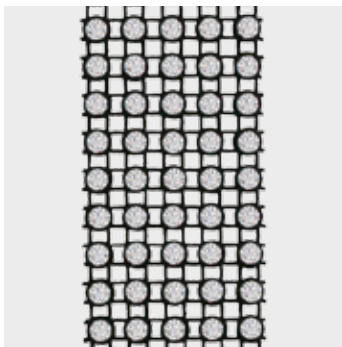

R	001, 005
SS	PP 24
M	10 M
	100%

50 004	R	SS	M	100%
Article number	Number of rows	Stone size	Minimum order quantity in meters (M)	Documentation size in %
	This article is available in 1 and 5 rows			

ORDERING EXAMPLE & PRODUCT VARIETY EXPLANATION

50 004	005	012	012	001
Article number	3-digit code for number of rows	Color of thread & net-edge	Color of casing	Color of crystals
	001 1 row 005 5 rows	(no net-edge): 012 Black 022 White (net-edge on 1 side/ 2 sides): 112/212 Black 122/122 White	010 Transparent 012 Black 022 White	Please see the respective product matrix for all available code references.

AVAILABLE OPTIONS WITH NET-EDGE

Articles 50 002–50 004 can be ordered with net-edge. This option is only available for one row and can be added on one side or on both sides of the banding. Please see the respective product matrix for all available options.

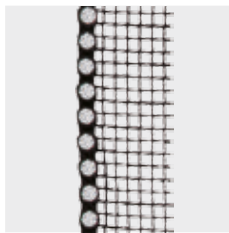

112 Black thread with net-edge on one side

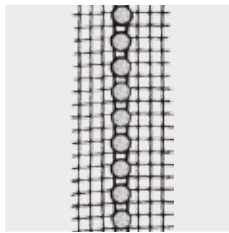

212 Black thread with net-edge on two sides

AVAILABLE THREAD & CASING COLORS

Basic Bandings are available in three different configurations. Please see the respective product matrix for all available options.



012 012
Black thread & casing



022 010
White thread & transparent casing



022 022
White thread & casing

Plastic Trimmings

Basic Bandings

50 002



R	001	
SS	PP 12	
M	10 M	100%

50 003

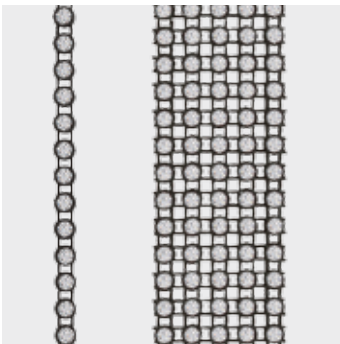

R	001	
SS	PP 18	
M	10 M	100%

50 004

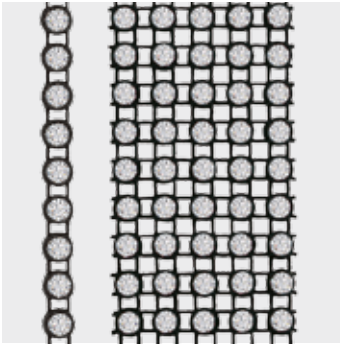

R	001, 005	
SS	PP 24	
M	10 M	100%

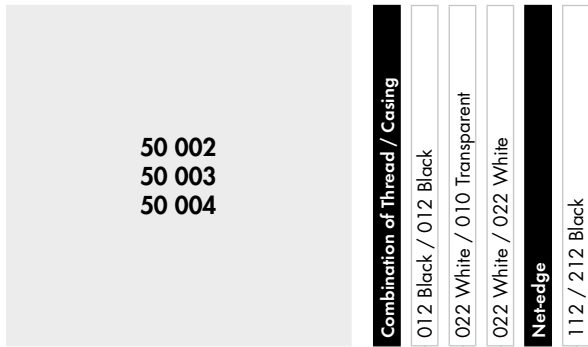

Crystal

Crystal F (001)

Colors

Plain Colors

Black Diamond F (215)

Jet F (280)

Sapphire F (206)

Smoked Topaz F (220)

Crystal Effects

Transparent Effects

Crystal AB F (001 AB)

Crystal Golden Shadow F (001 GSHA)*

* Not available for Basic Banding 50 002.

ARTICLE EXPLANATION

50 300

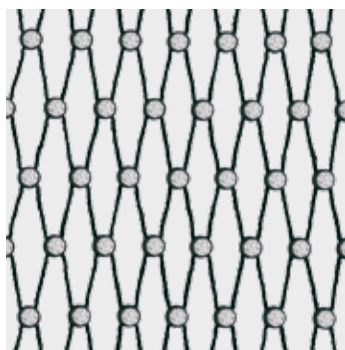

R	055
SS	PP 18
M	10 M
	100%

50 300	R	SS	M	100%
Article number	Number of rows	Stone size	Minimum order quantity in meters (M)	Documentation size in %
	This article is available in 55 rows.			

ORDERING EXAMPLE & PRODUCT VARIETY EXPLANATION

50 300	055	012	012	001
Article number	3-digit code for number of rows	Color of thread	Color of casing	Color of crystals
		012 Black 022 White	010 Transparent 012 Black	Please see the respective product matrix for all available code references.

AVAILABLE THREAD & CASING COLORS

Fishnet Bandings are available in two different configurations. Please see the respective product matrix for all available options.

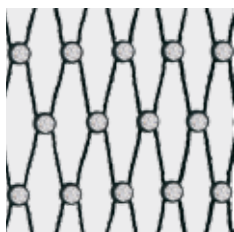

012 012
Black thread & casing



022 010
White thread & transparent casing

Plastic Trimmings

50 300

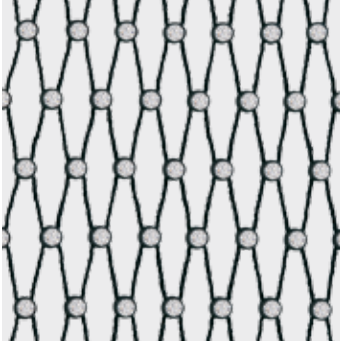

R	055	
SS	PP 18	
M	10 M	100%

Fishnet Bandings

50 300

Combination of Thread / Casing

Crystal	012 Black / 012 Black	022 White / 010 Transparent
Colors		
Plain Colors		
Crystal Effects		
Transparent Effects		
<div style="display: flex; align-items: center;"> <div style="width: 10px; height: 10px; background-color: #cccccc; border-radius: 50%; margin-right: 5px;"></div> Crystal F (001) </div>		
<div style="display: flex; align-items: center;"> <div style="width: 10px; height: 10px; background-color: black; border-radius: 50%; margin-right: 5px;"></div> Jet F (280) </div>		
<div style="display: flex; align-items: center;"> <div style="width: 10px; height: 10px; background-color: #cccccc; border-radius: 50%; margin-right: 5px;"></div> Crystal AB F (001 AB) </div>		
<div style="display: flex; align-items: center;"> <div style="width: 10px; height: 10px; background-color: #8b4513; border-radius: 50%; margin-right: 5px;"></div> Crystal Golden Shadow F (001 GSHA) </div>		

ARTICLE EXPLANATION

50 104

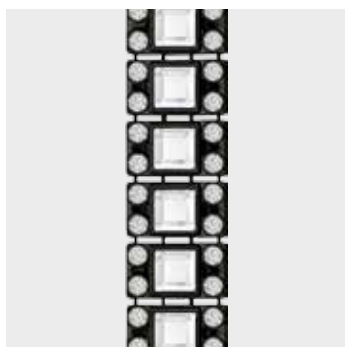

R	001
SS	PP 23, 6 mm (2400/2)
M	10 M* 100%

50 104	R	SS	M	100%
Article number	Number of rows	Stone size	Minimum order quantity in meters (M)	Documentation size in %
	This article is available in 1 row.	PP 23 for Chaton, 6 mm for article 2400/2		

ORDERING EXAMPLE & PRODUCT VARIETY EXPLANATION

50 104	001	012	012	001
Article number	3-digit code for number of rows	Color of thread	Color of casing	Color of crystals
		012 Black 022 White 081 Gold 082 Silver	010 Transparent 012 Black 022 White 081 Gold 082 Silver	Always 001 Crystal

* Please note: Bandings can be divided.

AVAILABLE THREAD & CASING COLORS

Decorative Bandings are generally available in four thread- and five* casing colors.

* Please see the respective product matrix for all available options.

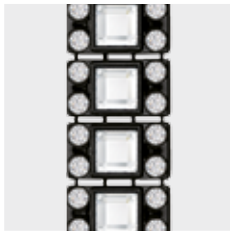

012 012
Black thread
& casing



081 081
Gold thread
& casing



022 010
White thread &
transparent
casing

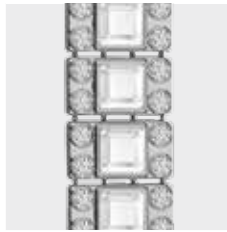

082 082
Silver thread
& casing



022 022
White thread
& casing

* Art. 50 100, 50 105 and 50 108 are only available in three different casing colors.

Plastic Trimmings

Decorative Bandings

50 100



R	001	
SS	6 mm (2400/2)	
M	10 M	100%

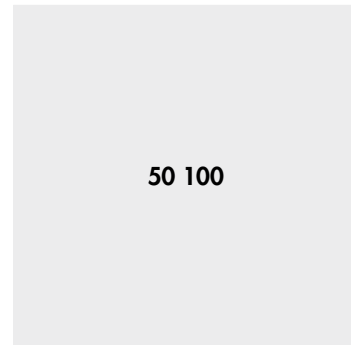

Crystal
Crystal F (001)

Combination of Thread / Casing
012 Black / 012 Black
022 White / 010 Transparent
022 White / 022 White

50 104

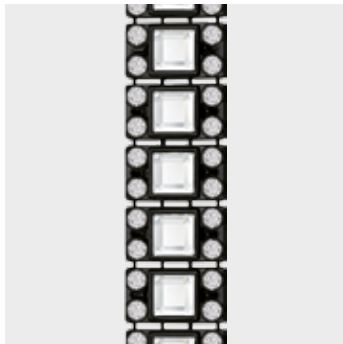

R	001	
SS	PP 23, 6 mm (2400/2)	
M	10 M	100%

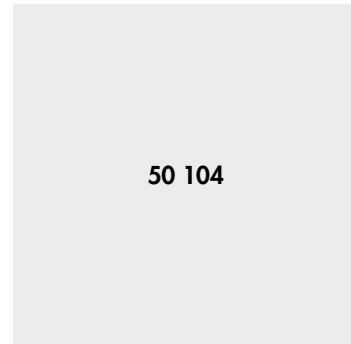

Crystal
Crystal F (001)

Combination of Thread / Casing
012 Black / 012 Black
022 White / 010 Transparent
022 White / 022 White
081 Gold / 081 Gold
082 Silver / 082 Silver

50 105

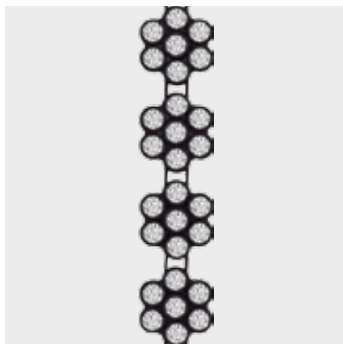

R	001	
SS	PP 25	
M	10 M	100%

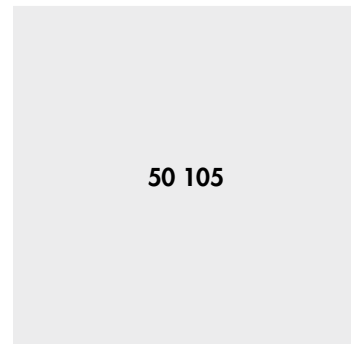

Crystal
Crystal F (001)

Combination of Thread / Casing
012 Black / 012 Black
022 White / 010 Transparent
022 White / 022 White

Plastic Trimmings

50 108

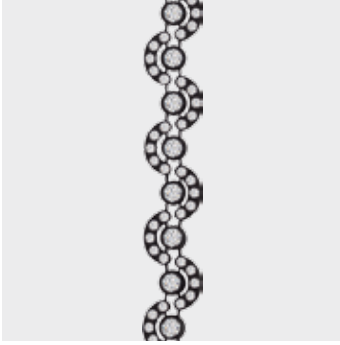

R	001	
SS	PP 10, PP 24	
M	10 M	100%

Decorative Bandings

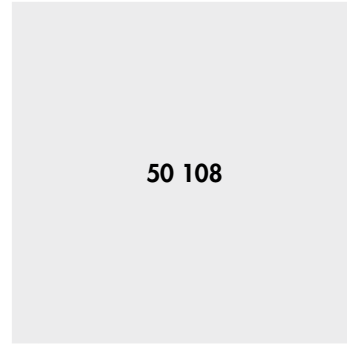

Crystal
Crystal F (001)

Combination of Thread / Casing
012 Black / 012 Black
022 White / 010 Transparent
022 White / 022 White

ARTICLE EXPLANATION

4720/101

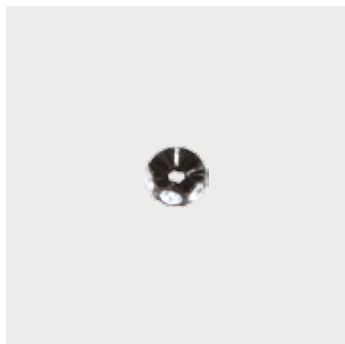

S	~Ø 5.5 mm
SS	PP 14
M	1,440 PCS 150%

4720/101	S	SS	M	150%
Article number	Component size in mm	Stone size	Minimum order quantity in pieces (PCS)	Documentation size in %
	This article has a diameter of 5.5 mm			

ORDERING EXAMPLE & PRODUCT VARIETY EXPLANATION

4720/101	012	001
Article number	Color of casing	Color of crystals
	010 Transparent	001 Crystal
	012 Black	001 AB Crystal AB
	022 White	280 Jet
	081 Gold	202 Aquamarine
	082 Silver	215 Black Diamond
		223 Light Rose
		539 Tanzanite

AVAILABLE CASING COLORS

Mini Rondelles are available in five different casing colors. Please see the respective product matrix for all available options.

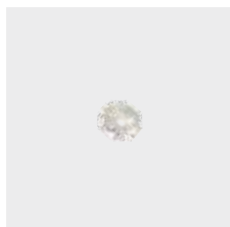

010
Transparent

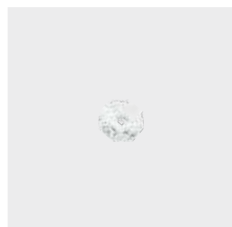

022
White

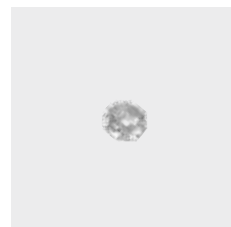

082
Silver

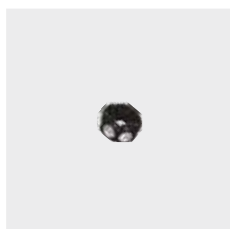

012
Black

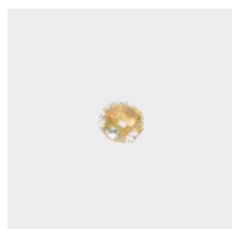

081
Gold

Plastic Trimmings

Plastic Components

Mini Rondelles

4720/101



S	~Ø 5.5 mm	
SS	PP 14	
M	1,440 PCS	150%

4720/102

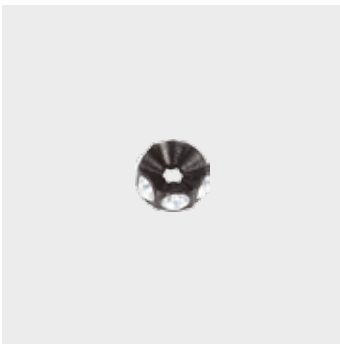

S	~Ø 6.5 mm	
SS	PP 18	
M	1,440 PCS	150%

4720/101
4720/102

Color of Casing

010 Transparent

012 Black

022 White

081 Gold

082 Silver

	010 Transparent	012 Black	022 White	081 Gold	082 Silver
Crystal					
Crystal F (001)	■	■	■	■	■
Colors					
Plain Colors					
Aquamarine F (202)	■	■	■	■	■
Black Diamond F (215)	■	■	■	■	■
Jet F (280)	■	■	■	■	■
Light Rose F (223)	■	■	■	■	■
Tanzanite F (539)	■	■	■	■	■
Crystal Effects					
Transparent Effects					
Crystal AB F (001 AB)	■	■	■		

Buttons, Fasteners & Zippers

Crystal Buttons can be used in exactly the same way as standard buttons. The assortment of available buttons ranges from those for shirts, blouses, jackets, and coats, to buttons for denim and accessories. They are suitable for hand and mechanical application. The assortment includes Crystal Buttons, Buttons with Plastic Shanks, Decorative and Jeans Buttons, as well as Snap Fasteners in a variety of sizes, colors, and effects.

Zippers from our assortment are unique because the crystals are integrated into the zipper teeth, allowing them to be used in the same way as standard zippers.

Buttons, Fasteners & Zippers

SUMMARY

1	2	3	3014 12 mm
			3015 10, 12, 14, 16, 18, 23, 27 mm
			3017 10, 12 mm
			3018 14, 18, 23 mm
			3019 12, 14, 16 mm
			3023 12x10.5, 14x12, 16x14 mm
			3024 23, 32 mm
			3035 10 mm
			3052 17, 26 mm
			3093 21x11, 30x16 mm
			3122 10 mm
			1770 7, 10, 12, 16, 20 mm

1	2	3	4	5	1780/100 11 mm
					1780/114 11 mm
					1781/100 11 mm
					1781/114 11 mm
					1782/190 16 mm
					1783/300 7 mm
					1786/100 11 mm
					1786/101 11 mm
					1790/100 14 mm
					1790/104 17 mm
					1790/114 14 mm
					1790/140 17 mm

1	2	1791/120 17 mm
		1792/100 17 mm
		1796/140 17 mm
		1810/539 9 mm
		1810/547 11 mm
		1810/120 13 mm
		1810/140 15 mm
		1811/100 12 mm
		1811/120 15 mm

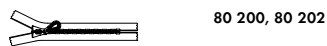

Crystal Buttons

- 1 Top view
- 2 Side view
- 3 Back view

Buttons with Plastic Shank

- 1 Top view
- 2 Side view

Snap Fasteners, Decorative & Jeans Buttons

- 1 Top view Fastener
- 2 Side view Front Part Fastener
- 3 Side view Back Part Fastener
- 4 Side view Front Part Counterpiece
- 5 Side view Back Part Counterpiece

Buttons with Metal Shank

- 1 Top view
- 2 Side view

ARTICLE EXPLANATION

3014

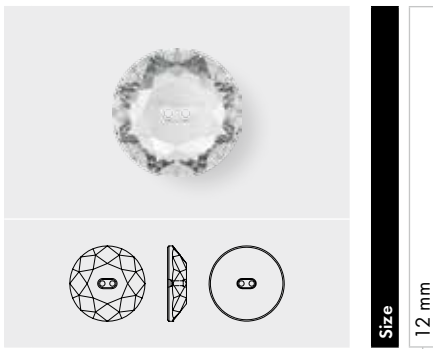

- Crystal**
- Crystal F (001)
- Colors**
- Plain Colors
- Jet (280)
- Crystal Effects**
- Transparent Effects
- Crystal Satin F (001 SAT)
- Color Effects**
- Metallic Effects
- Jet Hematite (280 HEM)

3014	Size	Color
Article number	Diameter or height of the Buttons in mm	Color assortment

ORDERING EXAMPLE & PRODUCT VARIETY EXPLANATION

3014	12	001 SAT
Article number	2-digit code for size	Color of crystal and foiling
	Please see the respective product matrix for all available size references.	Please see the respective product matrix for all available code references. M-Foiling available where indicated.

3014

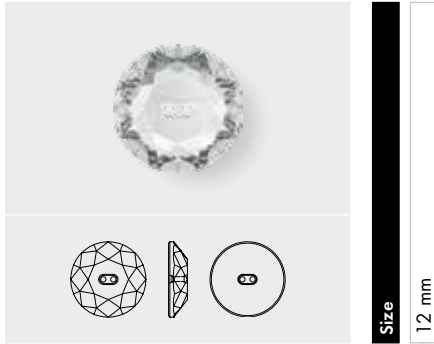

- Crystal**
- Crystal F (001)
- Colors**
- Plain Colors**
- Jet (280)
- Crystal Effects**
- Transparent Effects**
- Crystal Satin F (001 SAT)
- Color Effects**
- Metallic Effects**
- Jet Hematite (280 HEM)

Size
12 mm

3015

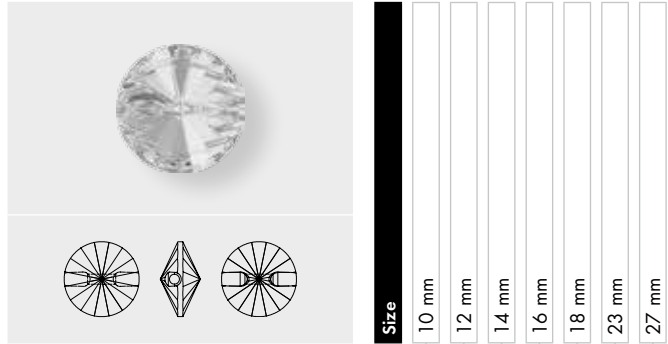

- Crystal**
- Crystal F (001)
- Colors**
- Plain Colors**
- Black Diamond F (215)
- Jet (280)
- Light Colorado Topaz F (246)
- Crystal Effects**
- Transparent Effects**
- Crystal AB F (001 AB)
- Crystal Golden Shadow F (001 GSHA)
- Crystal Satin F (001 SAT)
- Color Effects**
- Metallic Effects**
- Jet Hematite (280 HEM)

Size
10 mm
12 mm
14 mm
16 mm
18 mm
23 mm
27 mm

3017

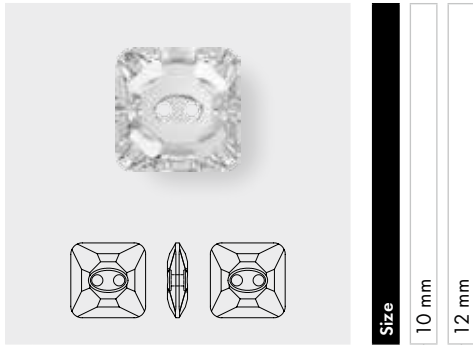

- Crystal**
- Crystal F (001)
- Colors**
- Plain Colors**
- Jet (280)
- Light Amethyst F (212)
- Montana F (207)
- Color Effects**
- Metallic Effects**
- Jet Hematite (280 HEM)

Size
10 mm
12 mm

3018 Rivoli Crystal Button (4 holes)

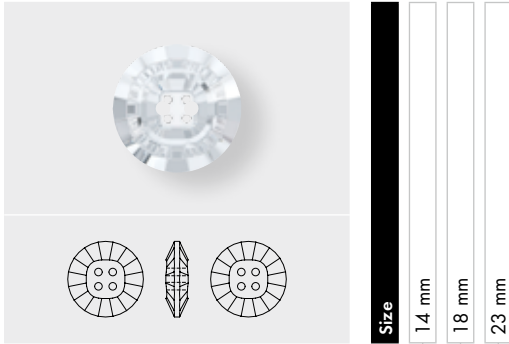

	14 mm	18 mm	23 mm
Crystal			
Crystal (001)	■	■	■
Crystal F (001)	■	■	■
Colors			
Plain Colors			
Jet (280)	■	■	■
Crystal Effects			
Transparent Effects			
Crystal AB (001 AB)	■	■	■
Crystal Antique Pink (001 ANTP)	■	■	■
Crystal Blue Shade (001 BLSH)	■	■	■
Crystal Golden Shadow (001 GSHA)	■	■	■
Crystal Luminous Green (001 LUMG)	■	■	■
Crystal Silver Night (001 SINI)	■	■	■
Metallic Effects			
Crystal Iridescent Green (001 IRIG)	■	■	■
Color Effects			
Metallic Effects			
Jet Hematite (280 HEM)	■	■	■

3019 Rivoli Crystal Button (2 holes)

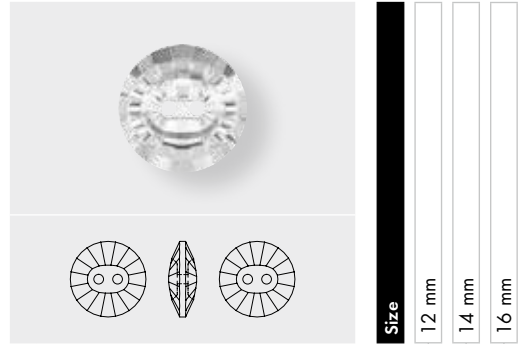

	12 mm	14 mm	16 mm
Crystal			
Crystal (001)	■	■	■
Crystal F (001)	■	■	■
Colors			
Plain Colors			
Dark Moss Green (260)	■	■	■
Jet (280)	■	■	■
Rosaline (508)	■	■	■
Crystal Effects			
Transparent Effects			
Crystal AB (001 AB)	■	■	■
Crystal Antique Pink (001 ANTP)	■	■	■
Crystal Blue Shade (001 BLSH)	■	■	■
Crystal Golden Shadow (001 GSHA)	■	■	■
Crystal Lilac Shadow (001 LISH)	■	■	■
Crystal Luminous Green (001 LUMG)	■	■	■
Crystal Silver Night (001 SINI)	■	■	■
Color Effects			
Metallic Effects			
Jet Hematite (280 HEM)	■	■	■

3023 Heart Crystal Button

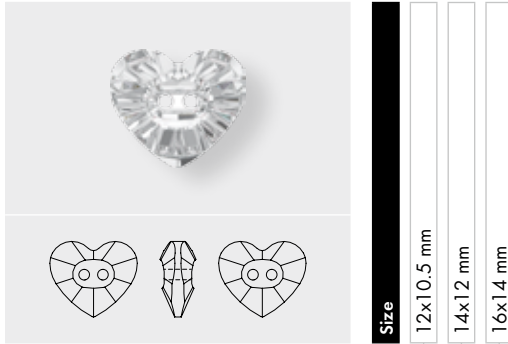

Crystal		12x10.5 mm	14x12 mm	16x14 mm
Crystal (001)	<input type="checkbox"/>	<input type="checkbox"/>	<input type="checkbox"/>	<input type="checkbox"/>
Crystal F (001)	<input type="checkbox"/>	<input type="checkbox"/>	<input type="checkbox"/>	<input type="checkbox"/>
Colors				
Plain Colors				
Dark Moss Green (260)	<input type="checkbox"/>	<input type="checkbox"/>	<input type="checkbox"/>	<input type="checkbox"/>
Fuchsia (502)	<input type="checkbox"/>	<input type="checkbox"/>	<input type="checkbox"/>	<input type="checkbox"/>
Jet (280)	<input type="checkbox"/>	<input type="checkbox"/>	<input type="checkbox"/>	<input type="checkbox"/>
Light Siam (227)	<input type="checkbox"/>	<input type="checkbox"/>	<input type="checkbox"/>	<input type="checkbox"/>
Rosaline (508)	<input type="checkbox"/>	<input type="checkbox"/>	<input type="checkbox"/>	<input type="checkbox"/>
Rose Peach (262)	<input type="checkbox"/>	<input type="checkbox"/>	<input type="checkbox"/>	<input type="checkbox"/>
Crystal Effects				
Transparent Effects				
Crystal AB (001 AB)	<input type="checkbox"/>	<input type="checkbox"/>	<input type="checkbox"/>	<input type="checkbox"/>
Crystal Antique Pink (001 ANTP)	<input type="checkbox"/>	<input type="checkbox"/>	<input type="checkbox"/>	<input type="checkbox"/>
Crystal Blue Shade (001 BLSH)	<input type="checkbox"/>	<input type="checkbox"/>	<input type="checkbox"/>	<input type="checkbox"/>
Crystal Golden Shadow (001 GSHA)	<input type="checkbox"/>	<input type="checkbox"/>	<input type="checkbox"/>	<input type="checkbox"/>
Crystal Lilac Shadow (001 LISH)	<input type="checkbox"/>	<input type="checkbox"/>	<input type="checkbox"/>	<input type="checkbox"/>
Crystal Silver Night (001 SINI)	<input type="checkbox"/>	<input type="checkbox"/>	<input type="checkbox"/>	<input type="checkbox"/>
Metallic Effects				
Crystal Rose Gold (001 ROGL)	<input type="checkbox"/>	<input type="checkbox"/>	<input type="checkbox"/>	<input type="checkbox"/>

3024 Dufflecoat Crystal Button

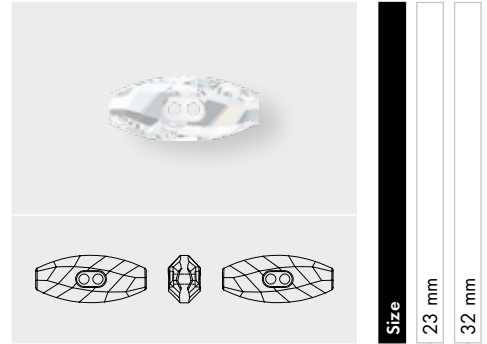

Crystal		23 mm	32 mm
Crystal (001)	<input type="checkbox"/>	<input type="checkbox"/>	<input type="checkbox"/>
Crystal F (001)	<input type="checkbox"/>	<input type="checkbox"/>	<input type="checkbox"/>
Colors			
Plain Colors			
Black Diamond (215)	<input type="checkbox"/>	<input type="checkbox"/>	<input type="checkbox"/>
Jet (280)	<input type="checkbox"/>	<input type="checkbox"/>	<input type="checkbox"/>
Light Colorado Topaz (246)	<input type="checkbox"/>	<input type="checkbox"/>	<input type="checkbox"/>
Light Turquoise (263)	<input type="checkbox"/>	<input type="checkbox"/>	<input type="checkbox"/>
Crystal Effects			
Transparent Effects			
Crystal AB (001 AB)	<input type="checkbox"/>	<input type="checkbox"/>	<input type="checkbox"/>
Crystal Blue Shade (001 BLSH)	<input type="checkbox"/>	<input type="checkbox"/>	<input type="checkbox"/>
Crystal Bronze Shade (001 BRSH)	<input type="checkbox"/>	<input type="checkbox"/>	<input type="checkbox"/>
Crystal Copper (001 COP)	<input type="checkbox"/>	<input type="checkbox"/>	<input type="checkbox"/>
Crystal Luminous Green (001 LUMG)	<input type="checkbox"/>	<input type="checkbox"/>	<input type="checkbox"/>
Crystal Red Magma (001 REDM)	<input type="checkbox"/>	<input type="checkbox"/>	<input type="checkbox"/>
Crystal Tabac (001 TAB)	<input type="checkbox"/>	<input type="checkbox"/>	<input type="checkbox"/>
Crystal Volcano (001 VOL)	<input type="checkbox"/>	<input type="checkbox"/>	<input type="checkbox"/>
Color Effects			
Metallic Effects			
Jet Hematite (280 HEM)	<input type="checkbox"/>	<input type="checkbox"/>	<input type="checkbox"/>

3035

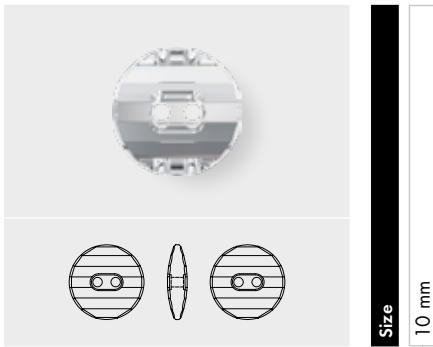

Size

10 mm

Crystal

Crystal F (001)

Colors

Plain Colors

Jet (280)

Crystal Effects

Transparent Effects

Crystal Satin F (001 SAT)

3052 Trapeze Crystal Button

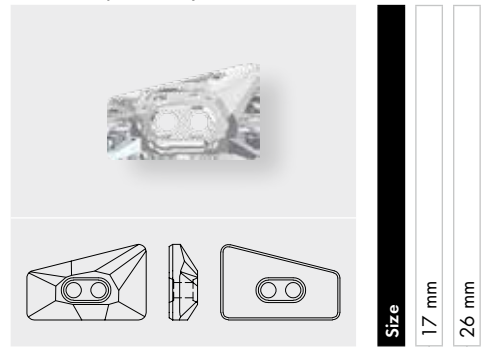

Size

17 mm

26 mm

Crystal

Crystal F (001)

Colors

Plain Colors

Black Diamond F (215)

Jet (280)

Crystal Effects

Transparent Effects

Crystal AB F (001 AB)

Crystal Luminous Green F (001 LUMG)

Color Effects

Metallic Effects

Jet Hematite (280 HEM)

3093 Chessboard Crystal Button

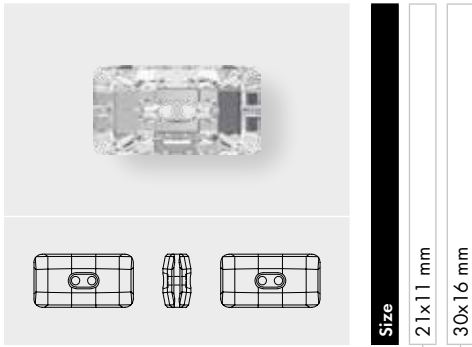

Size

21x11 mm

30x16 mm

Crystal

Crystal F (001)

Colors

Plain Colors

Black Diamond F (215)

Jet (280)

Light Colorado Topaz F (246)

Crystal Effects

Transparent Effects

Crystal Red Magma F (001 REDM)

Crystal Volcano F (001 VOL)

3122

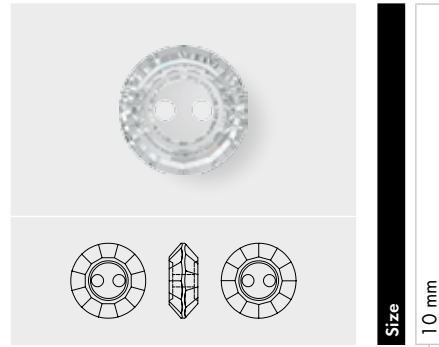

Size

10 mm

Crystal

Crystal F (001)

Colors

Plain Colors

Jet (280)

Crystal Effects

Transparent Effects

Crystal AB (001 AB)

ARTICLE EXPLANATION

1770

The product matrix for button 1770 is structured as follows:

- Color of Casing:** 010 Transparent, 012 Black, 022 White, 081 Gold, 082 Silver
- Size:** 129 (7 mm), 139 (10 mm), 147 (12 mm), 214 (16 mm), 218 (20 mm)
- Crystal:** Crystal F (001)

1770	Color of Casing	Color	Size
Article number	Color assortment	Crystal color assortment	Size code (diameter of the Button in mm)

ORDERING EXAMPLE & PRODUCT VARIETY EXPLANATION

1770	214	012	001
Article number	3-digit code for size	Color of casing	Color of crystal
	Please see the respective product matrix for all available size references.	010 Transparent 012 Black 022 White 081 Gold 082 Silver	Please see the respective product matrix for all available code references.

AVAILABLE CASING COLORS

Buttons with Plastic Shank are available in five different casing colors. Please see the respective product matrix for all available options.

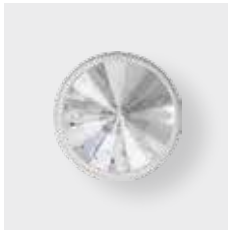

010
Transparent

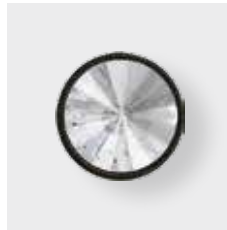

012
Black

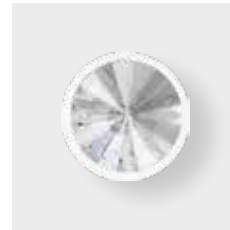

022
White

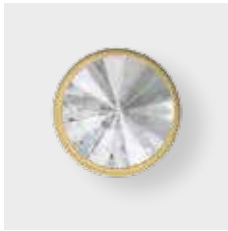

081
Gold

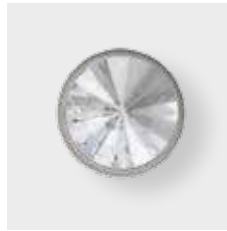

082
Silver

1770

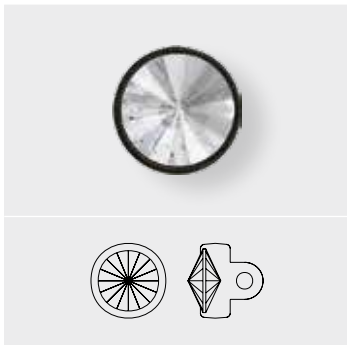

	Color of Casing					Size				
	010 Transparent	012 Black	022 White	081 Gold	082 Silver	129 (7 mm)	139 (10 mm)	147 (12 mm)	214 (16 mm)	218 (20 mm)
Crystal										
Crystal F (001)	■	■	■	■	■	■	■	■	■	■
Colors										
Plain Colors										
Aquamarine F (202)						■	■	■	■	
Jet F (280)	■	■	■	■	■	■	■	■	■	■
Light Rose F (223)	■					■	■	■	■	
Light Siam F (227)	■					■	■	■	■	
Peridot F (214)	■					■	■	■	■	
Crystal Effects										
Transparent Effects										
Crystal AB F (001)	■					■	■	■	■	
Crystal Golden Shadow F (001 GSHA)	■					■	■	■	■	

ARTICLE EXPLANATION

1780/114 Snap Fastener

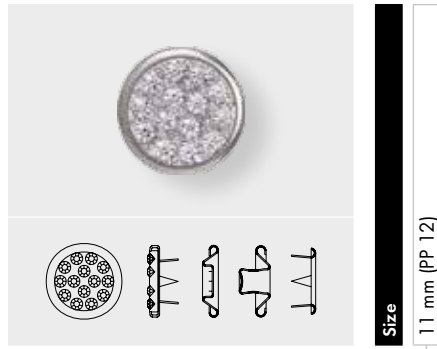

Size
11 mm (PP 12)

- Color of Casing**
- 081 Gold
 - 082 Silver
 - 086 Gun Metal
- Color of Component / Crystal**
- 012 Black / Crystal (001)
 - 082 Silver / Crystal (001)

1781/100 Decorative Button

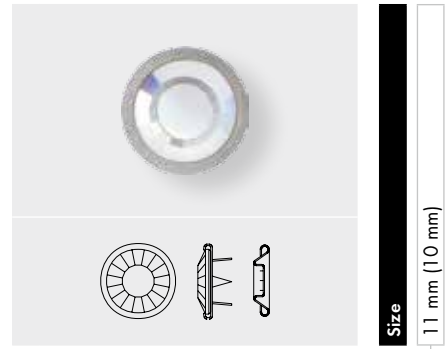

Size
11 mm (10 mm)

- Color of Casing**
- 081 Gold
 - 082 Silver
 - 086 Gun Metal
- Crystal**
- Crystal F (001)
- Crystal Effects**
- Transparent Effects**
- Crystal AB F (001 AB)
 - Crystal Golden Shadow F (001 GSHA)
 - Crystal Silver Shade F (001 SSHA)
- Color Effects**
- Metallic Effects**
- Jet Hematite F (280 HEM)
 - Jet Nut F (280 NUT)

1780/114	Color of Casing	Color of Component / Crystal	Size
Article number	Color assortment	Color of the component in combination with the crystal color	Diameter of the button in mm (stone size)
1781/100	Color of Casing	Color of Crystal	Size
Article number	Color assortment	Please see the respective product matrix for all available code references.	Diameter of the button in mm (stone size)

ORDERING EXAMPLE & PRODUCT VARIETY EXPLANATION

1780/114	082	082	001
Article number	Color of casing	Color of component	Color of crystal
	081 Gold 082 Silver 086 Gun Metal	010 Transparent 012 Black 082 Silver	Always 001 Crystal
1781/100	082	001	
Article number	Color of casing	Color of crystal	
	081 Gold 082 Silver 086 Gun Metal	Please see the respective product matrix for all available code references.	

AVAILABLE CASING COLORS

Snap Fasteners, Decorative and Jeans Buttons are available in three different casing colors. Please see the respective product matrix for all available options.

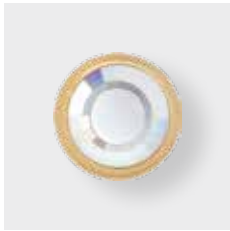

081
Gold



082
Silver

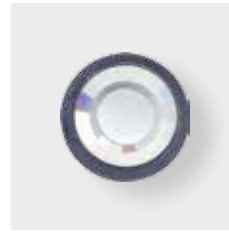

086
Gun Metal

AVAILABLE COMPONENT COLORS

Articles 1780/114, 1781/114, 1790/104 and 1790/114 are available with carrier components in three different colors. Please see the respective product matrix for all available options.



010
Transparent

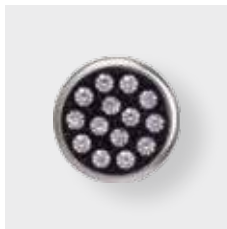

012
Black



082
Silver

1780/100 Snap Fastener

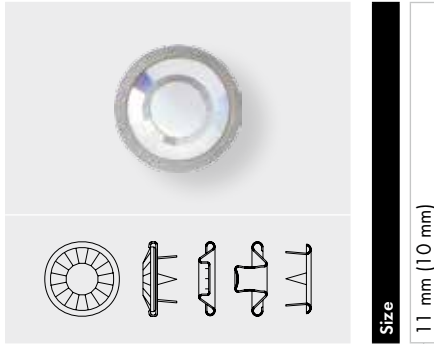

Size
11 mm (10 mm)

Color of Casing

081 Gold

082 Silver

086 Gun Metal

Crystal

Crystal F (001)

Crystal Effects

Transparent Effects

Crystal AB F (001 AB)

Crystal Golden Shadow F (001 GSHA)

Crystal Silver Shade F (001 SSHA)

Color Effects

Metallic Effects

Jet Hematite F (280 HEM)

Jet Nut F (280 NUT)

1780/114 Snap Fastener



Size
11 mm (PP 12)

Color of Casing

081 Gold

082 Silver

086 Gun Metal

Color of Component / Crystal

012 Black / Crystal (001)

082 Silver / Crystal (001)

1781/100 Decorative Button



Size
11 mm (10 mm)

Color of Casing

081 Gold

082 Silver

086 Gun Metal

Crystal

Crystal F (001)

Crystal Effects

Transparent Effects

Crystal AB F (001 AB)

Crystal Golden Shadow F (001 GSHA)

Crystal Silver Shade F (001 SSHA)

Color Effects

Metallic Effects

Jet Hematite F (280 HEM)

Jet Nut F (280 NUT)

1781/114 Decorative Button

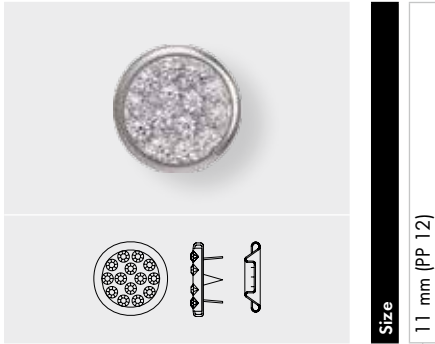

Size

11 mm (PP 12)

Color of Casing

- 081 Gold
- 082 Silver
- 086 Gun Metal

Color of Component / Crystal

- 012 Black / Crystal (001)
- 082 Silver / Crystal (001)

1782/190 Inset Snap Fastener

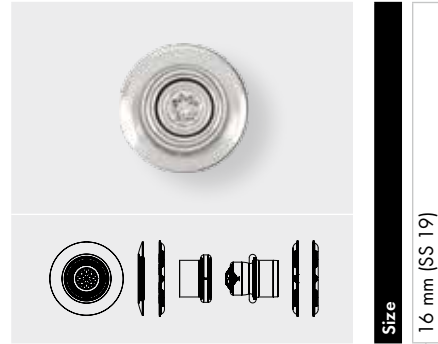

Size

16 mm (SS 19)

Color of Casing

- 082 Silver
- 086 Gun Metal

Crystal

- Crystal F (001)

Colors

Plain Colors

- Amethyst F (204)
- Black Diamond F (215)
- Fuchsia F (502)
- Jet F (280)
- Light Colorado Topaz F (246)
- Light Siam F (227)
- Light Turquoise F (263)
- Padparadscha F (542)
- Peridot F (214)
- Rose F (209)
- Sapphire F (206)
- Siam F (208)
- Smoked Topaz F (220)
- Topaz F (203)
- Vintage Rose F (319)

Opal Colors

- Air Blue Opal F (285)
- Pacific Opal F (390)

Crystal Effects

Transparent Effects

- Crystal AB F (001 AB)
- Crystal Blue Shade F (001 BLSH)
- Crystal Golden Shadow F (001 GSHA)
- Crystal Silver Shade F (001 SSHA)

1783/300 01 & 1783/300 02 XIRIUS FLAT BACK SNAP FASTENER

1783/300 01 XIRIUS Flat Back Snap Fastener



SS	SS 30	
M	72 pcs	100%

1783/300 02 XIRIUS Flat Back Snap Fastener

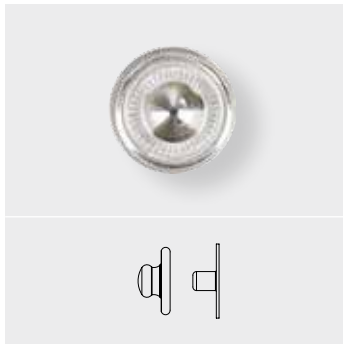

M	72 pcs	100%
---	--------	------

1783/300 01
1783/300 02

Size
7 mm (SS 30)

- Color of Casing**
- 081 Gold
- 082 Silver
- 086 Gun Metal
- Crystal**
- Crystal F (001)
- Colors**
- Plain Colors**
- Amethyst F (204)
- Aquamarine F (202)
- Black Diamond F (215)
- Blue Zircon F (229)
- Dark Indigo F (288)
- Denim Blue F (266)
- Emerald F (205)
- Fuchsia F (502)
- Jet F (280)
- Light Colorado Topaz F (246)
- Light Rose F (223)
- Purple Velvet F (277)
- Rose F (209)
- Siam F (208)
- Smoked Topaz F (220)
- Opal Colors**
- Palace Green Opal F (393)
- Crystal Effects**
- Transparent Effects**
- Crystal AB F (001 AB)
- Crystal Golden Shadow F (001 GSHA)
- Crystal Silver Night F (001 SINI)
- Crystal Silver Shade F (001 SSHA)
- Metallic Effects**
- Crystal Metallic Blue F (001 METBL)
- Color Effects**
- Metallic Effects**
- Jet Hematite F (280 HEM)

ORDERING EXAMPLE & PRODUCT VARIETY EXPLANATION

The XIRIUS Flat Back Snap Fastener is divided into two article parts:

1783/300 01

Decorative (upper) part (with crystal stone)

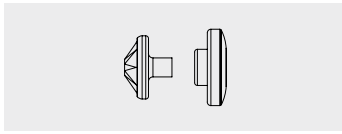

SS SS 30
M 72 pcs

1783/300 02

Closure (lower) part

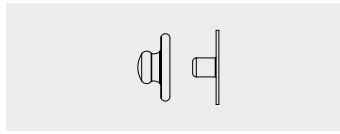

M 72 pcs

Each part has its own article number. Customers have to order both articles to get the complete product. But it's also possible to order only one part.

1783/300 01	082	001
Article number	Color of casing	Color of crystals
	081 Gold 082 Silver 086 Gun Metal	Please see the respective product matrix for all available code references.
1783/300 02	082	
Article number	Color of casing	
	081 Gold 082 Silver 086 Gun Metal	

1786/100 Chessboard Snap Fastener

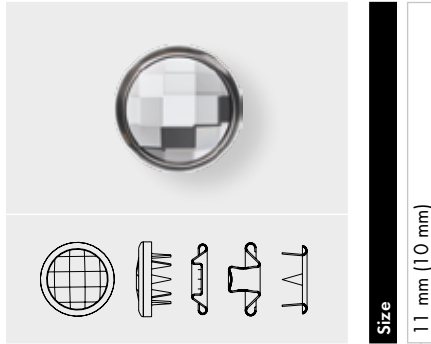

- Color of Casing**
- 081 Gold
- 082 Silver
- 086 Gun Metal
- Crystal**
- Crystal F (001)
- Colors**
- Plain Colors**
- Aquamarine F (202)
- Black Diamond F (215)
- Jet F (280)
- Crystal Effects**
- Transparent Effects**
- Crystal AB F (001 AB)
- Crystal Antique Pink F (001 ANTP)
- Crystal Golden Shadow F (001 GSHA)
- Crystal Red Magma F (001 REDM)

1786/101 Chessboard Decorative Button

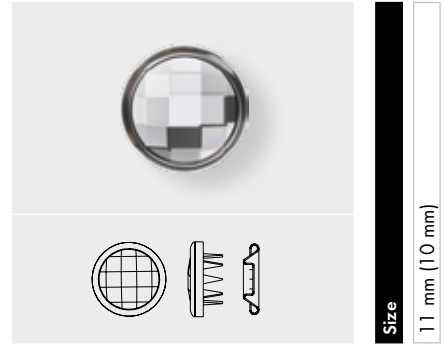

- Color of Casing**
- 081 Gold
- 082 Silver
- 086 Gun Metal
- Crystal**
- Crystal F (001)
- Colors**
- Plain Colors**
- Aquamarine F (202)
- Black Diamond F (215)
- Jet F (280)
- Crystal Effects**
- Transparent Effects**
- Crystal AB F (001 AB)
- Crystal Antique Pink F (001 ANTP)
- Crystal Golden Shadow F (001 GSHA)
- Crystal Red Magma F (001 REDM)

1790/100 Jeans Button

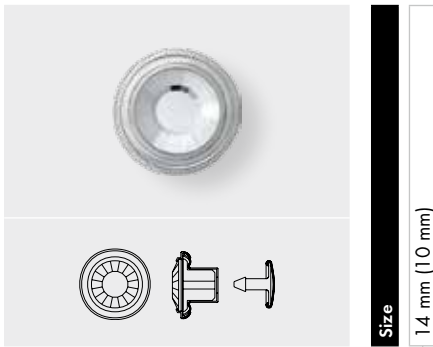

Color of Casing

081 Gold

082 Silver

086 Gun Metal

Crystal

Crystal F (001)

Crystal Effects

Transparent Effects

Crystal AB F (001 AB)

Crystal Golden Shadow F (001 GSHA)

Crystal Silver Shade F (001 SSHA)

Color Effects

Metallic Effects

Jet Hematite F (280 HEM)

Jet Nut F (280 NUT)

1790/104 Jeans Button



Color of Casing

081 Gold

082 Silver

086 Gun Metal

Color of Component / Crystal

010 Transparent / Crystal (001)

012 Black / Crystal (001)

082 Silver / Crystal (001)

1790/114 Jeans Button



Size

14 mm (PP 12)

Color of Casing

081 Gold

082 Silver

086 Gun Metal

Color of Component / Crystal

012 Black / Crystal (001)

082 Silver / Crystal (001)

1790/140 Jeans Button

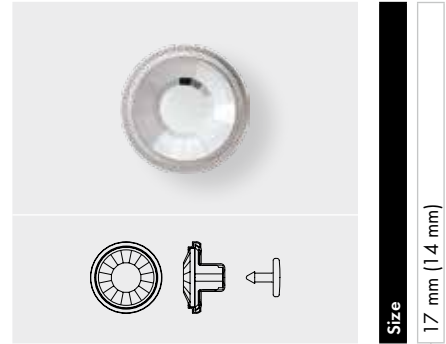

Size

17 mm (1.4 mm)

Color of Casing

081 Gold

082 Silver

086 Gun Metal

Crystal

Crystal F (001)

Crystal Effects

Transparent Effects

Crystal AB F (001 AB)

Crystal Golden Shadow F (001 GSHA)

Crystal Silver Shade F (001 SSHA)

Color Effects

Metallic Effects

Jet Hematite F (280 HEM)

Jet Nut F (280 NUT)

1791/120

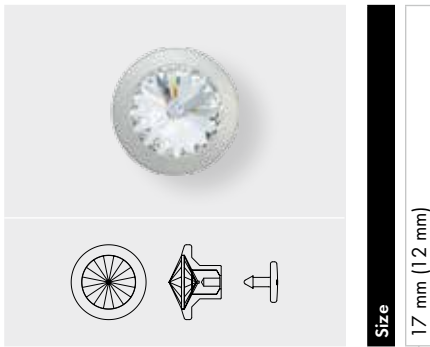

Size

17 mm (12 mm)

- Color of Casing**
- 081 Gold
- 082 Silver
- 086 Gun Metal
- Crystal**
- Crystal F (001)
- Colors**
- Plain Colors**
- Black Diamond F (215)
- Dark Moss Green F (260)
- Jet F (280)
- Light Colorado Topaz F (246)
- Light Peach F (362)
- Light Sapphire F (211)
- Light Silk F (261)
- Tangerine F (259)
- Crystal Effects**
- Transparent Effects**
- Crystal AB F (001 AB)
- Crystal Golden Shadow F (001 GSHA)
- Crystal Lilac Shadow F (001 LISH)
- Crystal Silver Shade F (001 SSHA)
- Crystal Vitrail Light F (001 VL)
- Metallic Effects**
- Crystal Iridescent Green F (001 IRIG)
- Crystal Rose Gold F (001 ROGL)
- Color Effects**
- Metallic Effects**
- Jet Hematite F (280 HEM)

1792/100



Size

17 mm (10 mm)

- Color of Casing**
- 081 Gold
- 082 Silver
- 086 Gun Metal
- Crystal**
- Crystal F (001)
- Colors**
- Plain Colors**
- Black Diamond F (215)
- Dark Moss Green F (260)
- Denim Blue F (266)
- Greige F (284)
- Jet F (280)
- Light Silk F (261)
- Light Turquoise F (263)
- Padparadscha F (542)
- Purple Velvet F (277)
- Rose Peach F (262)
- Tangerine F (259)
- Tanzanite F (539)
- Vintage Rose F (319)
- Opal Colors**
- Chrysolite Opal F (294)
- Palace Green Opal F (393)
- Rose Water Opal F (395)
- Crystal Effects**
- Transparent Effects**
- Crystal Antique Pink F (001 ANTP)
- Crystal Blue Shade F (001 BLSH)
- Crystal Golden Shadow F (001 GSHA)
- Crystal Lilac Shadow F (001 LISH)
- Crystal Luminous Green F (001 LUMG)
- Crystal Silver Shade F (001 SSHA)
- Metallic Effects**
- Crystal Iridescent Green F (001 IRIG)
- Crystal Rose Gold F (001 ROGL)

1796/140 Chessboard Button

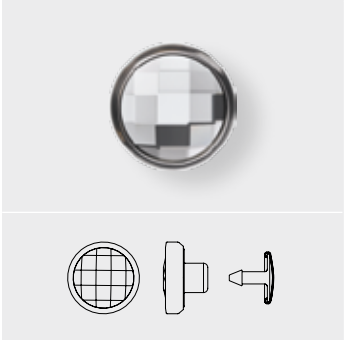

Size
17 mm (14 mm)

Color of Casing

- 081 Gold
- 082 Silver
- 086 Gun Metal

Crystal

- Crystal F (001)

Colors

Plain Colors

- Aquamarine F (202)
- Black Diamond F (215)
- Jet F (280)

Crystal Effects

Transparent Effects

- Crystal Golden Shadow F (001 GSXA)
- Crystal Red Magma F (001 REDM)

ARTICLE EXPLANATION

1810/S47

1810/S47	Color of Casing	Color	Size
Article number	Color assortment	Crystal color assortment	Diameter of the button in mm (stone size)

ORDERING EXAMPLE & PRODUCT VARIETY EXPLANATION

1810/S47	082	001
Article number	Color of casing	Color of crystal
	081 Gold 082 Silver 086 Gun Metal	Please see the respective product matrix for all available code references.

AVAILABLE CASING COLORS

Buttons with Metal Shank are available in three different casing colors. Please see the respective product matrix for all available options.



Buttons, Fasteners & Zippers

Buttons with Metal Shank

1810/S39

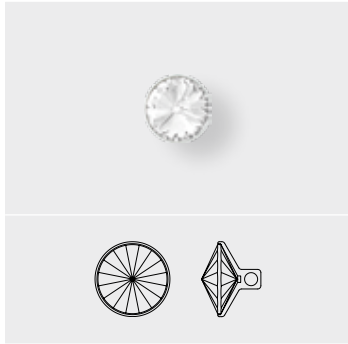

Size
9 mm (SS 39)

1810/S47

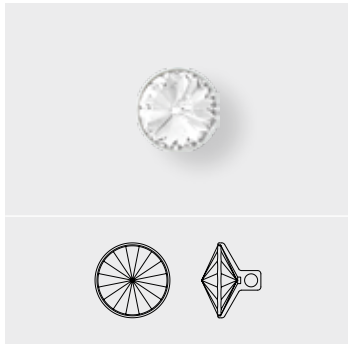

Size
11 mm (SS 47)

1810/120

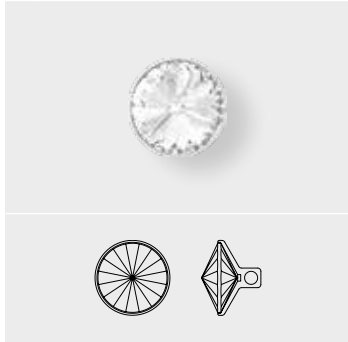

Size
13 mm (12 mm)

1810/140

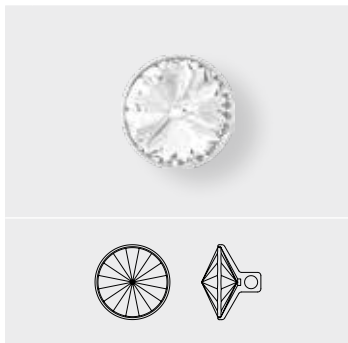

Size
15 mm (14 mm)

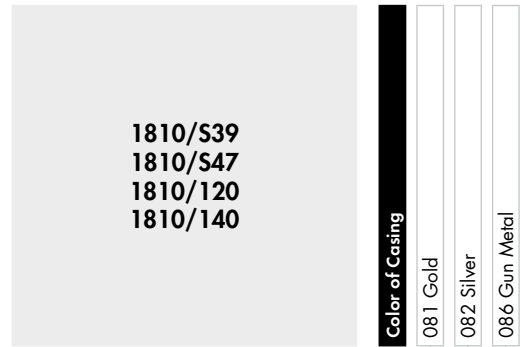

	081 Gold	082 Silver	086 Gun Metal
Crystal			
Crystal F (001)	■	■	■
Colors			
Plain Colors			
Black Diamond F (215)	■	■	■
Dark Moss Green F (260)	■	■	■
Jet F (280)	■	■	■
Light Colorado Topaz F (246)	■	■	■
Light Sapphire F (211)	■	■	■
Light Silk F (261)	■	■	■
Tangerine F (259)	■	■	■
Crystal Effects			
Transparent Effects			
Crystal AB F (001 AB)	■	■	■
Crystal Golden Shadow F (001 GSHA)	■	■	■
Crystal Lilac Shadow F (001 LISH)	■	■	■
Crystal Silver Shade F (001 SSHA)	■	■	■
Crystal Vitrail Light F (001 VL)	■	■	■
Metallic Effects			
Crystal Iridescent Green F (001 IRIG)	■	■	■
Crystal Rose Gold F (001 ROGL)	■	■	■
Color Effects			
Metallic Effects			
Jet Hematite F (280 HEM)	■	■	■

Buttons, Fasteners & Zippers

Buttons with Metal Shank

1811/100



Size

12 mm (10 mm)

1811/120

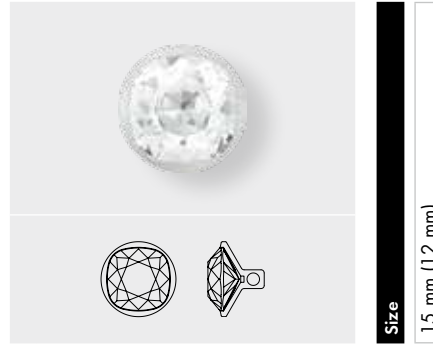

Size

15 mm (12 mm)

1811/100 1811/120	Color of Casing	081 Gold	082 Silver	086 Gun Metal
----------------------	-----------------	----------	------------	---------------

Crystal				
Crystal F (001)	■	■	■	
Colors				
Plain Colors				
Black Diamond F (215)	■	■	■	
Dark Moss Green F (260)	■	■	■	
Denim Blue F (266)	■	■	■	
Greige F (284)	■	■	■	
Jet F (280)	■	■	■	
Light Silk F (261)	■	■	■	
Light Turquoise F (263)	■	■	■	
Padparadscha F (542)	■	■	■	
Purple Velvet F (277)	■	■	■	
Rose Peach F (262)	■	■	■	
Tangerine F (259)*	■	■	■	
Tanzanite F (539)	■	■	■	
Vintage Rose F (319)	■	■	■	
Opal Colors				
Chrysolite Opal F (294)	■	■	■	
Palace Green Opal F (393)	■	■	■	
Rose Water Opal F (395)	■	■	■	

1811/100 1811/120	Color of Casing	081 Gold	082 Silver	086 Gun Metal
----------------------	-----------------	----------	------------	---------------

Crystal Effects				
Transparent Effects				
Crystal Antique Pink F (001 ANTP)	■	■	■	
Crystal Blue Shade F (001 BLSH)	■	■	■	
Crystal Golden Shadow F (001 GSHA)	■	■	■	
Crystal Lilac Shadow F (001 LISH)	■	■	■	
Crystal Luminous Green F (001 LUMG)	■	■	■	
Crystal Silver Shade F (001 SSHA)	■	■	■	
Metallic Effects				
Crystal Iridescent Green F (001 IRIG)	■	■	■	
Crystal Rose Gold F (001 ROGL)	■	■	■	

* Not available for article 1811/120.

AVAILABLE TYPES OF ZIPPERS



801.. Classic Zipper

Stone 1028

Stone size PP 18

DIN 3419 Type 10

100%



802.. Magic Zipper

Stone 1106

Stone size SS 24

DIN 3419 Type 10

100%



804.. Brilliant Zipper

Stone 1088

Stone size PP 24

DIN 3419 Type 20

100%

ARTICLE EXPLANATION

80 102



Open ended		
M	12 PCS	50%

80 102	M	50%
Article number	Minimum order quantity in pieces (PCS)	Documentation size in %

ORDERING EXAMPLE & PRODUCT VARIETY EXPLANATION

80 102	020	012	001	120
Article number	3-digit code for length	Color of material	Color of crystals	Type of puller
801.. Classic Zippers	Standard lengths: 10 to 75 cm	012 Black	Please see respective product matrix for all available code references.	120 Classic Puller
802.. Magic Zippers		022 White		220 Magic Puller
	Please see the respective product matrix for all available options. In-between lengths (e.g. 27 cm) as well as lengths over 75 cm are special productions and available on request.			

80 100



Closed at one end

M	12 PCS	50%
---	--------	-----

80 102



Open ended

M	12 PCS	50%
---	--------	-----



- Crystal**
- Crystal F (001)
- Colors**
- Plain Colors
- Jet F (280)

Standard Length in cm	Color of Material
010	012 Black
015	022 White
020	
025	
030	
035	
040	
045	
050	
055	
060	
065	
070	
075	

80 200



Closed at one end

M	12 PCS	50%
---	--------	-----

80 202



Open ended

M	12 PCS	50%
---	--------	-----

15 Buttons, Fasteners & Zippers



Crystal
Crystal F (001)

Standard Length in cm	010	015	020	025	030	035	040	045	050	055	060	065	070	075
Color of Material	012 Black	022 White												

ARTICLE EXPLANATION

80 400



Closed at one end

M	36 PCS	40%
---	--------	-----

80 400	M	40%
Article number	Minimum order quantity in pieces (PCS)	Documentation size in %

ORDERING EXAMPLE & PRODUCT VARIETY EXPLANATION

80 400	020	Z580	Z580	001
Article number	3-digit code for length	Color of fabric	Color of acrylic	Color of crystals
804.. Brilliant Zipper	Standard lengths: 10 to 75 cm Please see the respective product matrix for all available options. Lengths over 75 cm as well as in-between lengths (e.g. 12.5 cm) are special productions and are available on request.	Please see respective product matrix for all available code references.		

AVAILABLE TYPES OF ZIPPERS



804.. Brilliant Zipper
 Stone 1088
 Stone size PP 24
 DIN 3419 Type 20

	100%
--	------

80 400



Closed at one end

M 36 PCS	40%
----------	-----

80 402



Open ended

M 36 PCS	40%
----------	-----

80 403

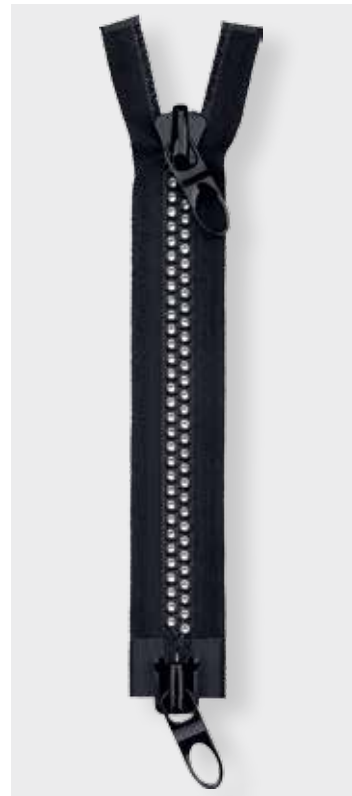

Open ended at one side, "two sliders inside out"
 Closes from inside to outside, pullers in same direction

M 36 PCS	40%
----------	-----



Standard Length in cm	010	015	020	025	030	035	040	045	050	055	060	065	070	075
-----------------------	-----	-----	-----	-----	-----	-----	-----	-----	-----	-----	-----	-----	-----	-----

Crystal	Fabric Color	Acryl Color												
Crystal F (001)	Z580	Z580	■	■	■	■	■	■	■	■	■	■	■	■
Crystal F (001)	Z501	Z501	■	■	■	■	■	■	■	■	■	■	■	■
Colors														
Plain Colors														
Aquamarine F (202)	Z162	Z501	■	■	■	■	■	■	■	■	■	■	■	■
Fern Green F (291)	Z152	Z152	■	■	■	■	■	■	■	■	■	■	■	■
Fuchsia F (502)	Z524	Z524	■	■	■	■	■	■	■	■	■	■	■	■
Hyacinth F (236)	Z819	Z819	■	■	■	■	■	■	■	■	■	■	■	■
Jet F (280)	Z580	Z580	■	■	■	■	■	■	■	■	■	■	■	■
Light Colorado Topaz F (246)	Z868	Z868	■	■	■	■	■	■	■	■	■	■	■	■
Montana F (207)	Z058	Z058	■	■	■	■	■	■	■	■	■	■	■	■
Sunflower F (292)	Z506	Z506	■	■	■	■	■	■	■	■	■	■	■	■
Multi F (M200)*	Z112	Z112	■	■	■	■	■	■	■	■	■	■	■	■

SPECIAL PRODUCTIONS

In addition to the Brilliant Zipper standard assortment, customers can choose from all available colors in the loose XIRIUS Chaton assortment (PP 24) and can combine them with tone-on-tone carrier material. They also have the possibility to create an individual color combination of fabric, acryl and crystal for the zipper. Customers can choose between 600 different fabric and acryl colors from the YKK Color Card provided by their sales representative.

The minimum order quantity for special productions is 180 pcs.

* Multi F (M200) consists of Crystal, Light Topaz, Black Diamond, Denim Blue, Chrysolite.

PRODUCT DETAILS

Article Size	Packing Unit = Minimum Order Quantity in Pieces	Average Net Weight in Gram per Packing Unit Crystal (001)	Average Gross Weight in Gram per Packing Unit Crystal (001)
3014			
12 mm	48	28.8	47.3
3015			
10 mm	72	35.4	54.0
12 mm	48	41.4	59.9
14 mm	36	42.5	59.8
16 mm	24	47.6	64.9
18 mm	24	62.1	79.1
23 mm	8	42.9	64.9
27 mm	8	67.6	89.6
3017			
10 mm	72	39.8	58.4
12 mm	48	39.0	57.6
3018			
14 mm	48	36.29	57.16
18 mm	24	38.30	71.40
23 mm	16	53.76	86.28
3019			
12 mm	48	31.2	51.34
14 mm	36	41.4	59.30
16 mm	24	39.8	62.48
3023			
12x10.5 mm	144	81.043	110.195
14x12 mm	144	131.846	158.337
16x14 mm	72	90.115	98.522
3024			
23 mm	36	78.61	96.33
32 mm	30	138.11	167.21
3035			
10 mm	72	26.7	45.3
3052			
17 mm	48	54.80	69.73
26 mm	20	63.61	89.71
3093			
21x11 mm	36	81.4	112.2
30x16 mm	30	223.5	251.7
3122			
10 mm	72	33.7	52.3
1770			
7 mm	288	61.2	75.8
10 mm	144	50.0	74.0
12 mm	144	120.0	132.9
16 mm	72	120.6	133.5
20 mm	24	82.2	97.7
1780/100			
11 mm	72	108.1	135.3
1780/114			
11 mm	72	125.1	152.3
1781/100			
11 mm	72	67.2	84.3
1781/114			
11 mm	72	84.3	101.4

Article Size	Packing Unit = Minimum Order Quantity in Pieces	Average Net Weight in Gram per Packing Unit Crystal (001)	Average Gross Weight in Gram per Packing Unit Crystal (001)
1782/190 16 mm	72	84.3	101.4
1783/300 01 7 mm	72	43.2	58.7
1783/300 02 7 mm	72	28.8	49.9
1786/100 11 mm	72	108.1	135.3
1786/101 11 mm	72	67.2	84.3
1790/100 14 mm	72	141.4	163.4
1790/104 17 mm	24	54.6	73.6
1790/114 14 mm	72	129.7	148.7
1790/140 17 mm	24	65.8	87.8
1791/120 17 mm	24	65.1	84.1
1792/100 17 mm	24	61.4	80.4
1796/140 17 mm	24	57	73.3
1810/S39 9 mm	24	10.0	26.1
1810/S47 11 mm	24	19.0	35.1
1810/120 13 mm	24	26.1	42.2
1810/140 15 mm	24	40.7	56.8
1811/100 12 mm	24	22.3	38.4
1811/120 15 mm	24	39.3	55.4

Article Length Code	Exact Length in mm	Article Length Code	Exact Length in mm	Article Length Code	Exact Length in mm
Classic Zipper 80 100		Magic Zipper 80 200		Brilliant Zipper 80 400	
010	101.6	010	105.5	010	111
015	152.6	015	151.1	015	161
020	203.6	020	204.3	020	211
025	254.6	025	257.5	025	260
030	305.6	030	303.1	030	310
035	356.6	035	356.3	035	360
040	407.6	040	401.9	040	409
045	458.6	045	455.1	045	459
050	509.6	050	500.7	050	509
055	560.6	055	553.9	055	558
060	611.6	060	607.1	060	608
065	654.1	065	652.7	065	657
070	705.1	070	698.3	070	707
075	747.6	075	751.5	075	757

Metal Trimmings

Metal Trimmings are forward-integrated metal products. They can be sewn by hand or machine and mechanically applied onto different fabrics or other materials. Metal Trimmings are bestsellers among the textile, shoe, and accessories segments because their wide range of application possibilities ensure that they can be used in a multitude of different ways.

ARTICLE EXPLANATION

55 000



R	001-024
SS	SS 20
M	05 M
	100%

55 000	R	SS	M	100%
Article number	Number of rows	Stone size	Minimum order quantity in meters (M)	Documentation size in %
	This article is available from 1 to 24 rows.			

ORDERING EXAMPLE & PRODUCT VARIETY EXPLANATION

55 000	004	012	082	001
Article number	3-digit code for number of rows	Color of thread (without net-edge, on 1 side/2 sides): 012 Black (without net-edge) 022 White (without net-edge) 112 Black (on 1 side) 212 Black (on 2 sides) 122 White (on 1 side) 222 White (on 2 sides)	Color of casing 081 Gold 082 Silver 086 Gun Metal	Color of crystals Please see the respective product matrix for all available code references.

Please note: Articles with 1 row are only available with one or two side net-edge. The articles 52 001, 52 501, 55 001 and 55 501, however, can be ordered without net-edge.

AVAILABLE OPTIONS WITH NET-EDGE

All Chaton & Flat Back Bandings can be ordered with net-edge. This option can be added on one side or on both sides of the banding. Please see the respective product matrix for all available options.

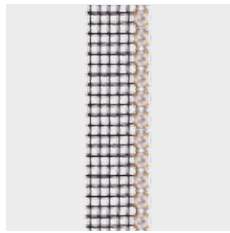

112
Black net-edge
on 1 side

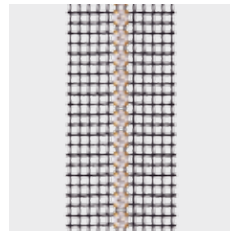

212
Black net-edge
on 2 sides

AVAILABLE COMBINATIONS OF THREAD & CASING

Chaton and Flat Back Bandings are available in three different casing colors and can be combined with two different thread/net-edge colors. Please see the respective product matrix for all available options.

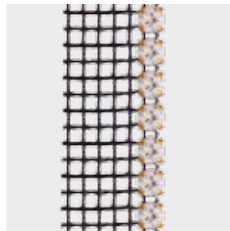

112 081
Black thread,
gold casing

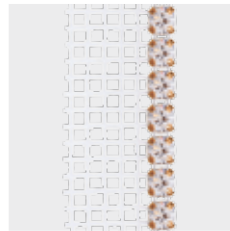

122 081
White thread,
gold casing

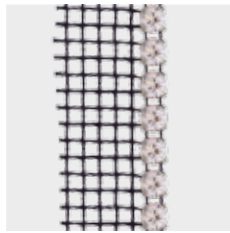

112 082
Black thread,
silver casing

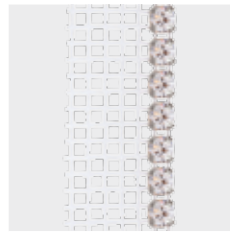

122 082
White thread,
silver casing

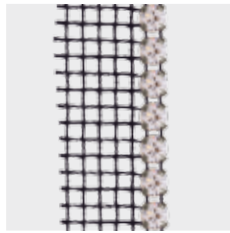

112 086
Black thread,
gun metal casing

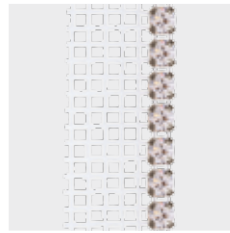

122 086
White thread,
gun metal casing

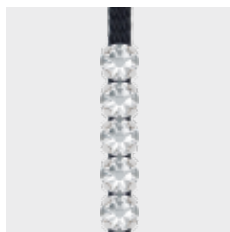

012 082
Black

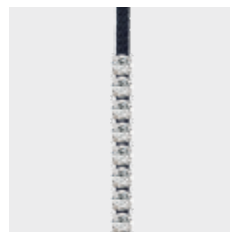

012 082
Black

Please note: The connective cotton thread differs from the net-edge.

Metal Trimmings

Chaton Bandings

52 000



R	001-024	
SS	SS 18	
M	05 M	100%

52 001*

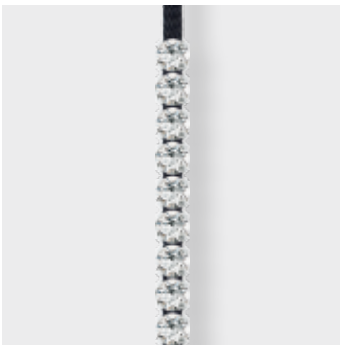

R	001	
SS	SS 18	
M	10 M	100%

52 000 52 001*		Color of Thread / Net-edge			Color of Casing		
		012 / 112 / 212 Black	022 / 122 / 222 White	081 Gold	082 Silver	086 Gun Metal	
Crystal							
<input type="checkbox"/>	Crystal F (001)	<input checked="" type="checkbox"/>	<input checked="" type="checkbox"/>	<input checked="" type="checkbox"/>	<input checked="" type="checkbox"/>	<input checked="" type="checkbox"/>	
Colors							
Plain Colors							
<input type="checkbox"/>	Black Diamond F (215)	<input checked="" type="checkbox"/>	<input checked="" type="checkbox"/>	<input checked="" type="checkbox"/>	<input checked="" type="checkbox"/>	<input checked="" type="checkbox"/>	
<input type="checkbox"/>	Fuchsia F (502)	<input checked="" type="checkbox"/>	<input checked="" type="checkbox"/>	<input checked="" type="checkbox"/>	<input checked="" type="checkbox"/>	<input checked="" type="checkbox"/>	
<input type="checkbox"/>	Greige F (284)	<input checked="" type="checkbox"/>	<input checked="" type="checkbox"/>	<input checked="" type="checkbox"/>	<input checked="" type="checkbox"/>	<input checked="" type="checkbox"/>	
<input type="checkbox"/>	Jet F (280)	<input checked="" type="checkbox"/>	<input checked="" type="checkbox"/>	<input checked="" type="checkbox"/>	<input checked="" type="checkbox"/>	<input checked="" type="checkbox"/>	
<input type="checkbox"/>	Light Colorado Topaz F (246)	<input checked="" type="checkbox"/>	<input checked="" type="checkbox"/>	<input checked="" type="checkbox"/>	<input checked="" type="checkbox"/>	<input checked="" type="checkbox"/>	
<input type="checkbox"/>	Light Peach F (362)	<input checked="" type="checkbox"/>	<input checked="" type="checkbox"/>	<input checked="" type="checkbox"/>	<input checked="" type="checkbox"/>	<input checked="" type="checkbox"/>	
<input type="checkbox"/>	Siam F (208)	<input checked="" type="checkbox"/>	<input checked="" type="checkbox"/>	<input checked="" type="checkbox"/>	<input checked="" type="checkbox"/>	<input checked="" type="checkbox"/>	
<input type="checkbox"/>	Smoked Topaz F (220)	<input checked="" type="checkbox"/>	<input checked="" type="checkbox"/>	<input checked="" type="checkbox"/>	<input checked="" type="checkbox"/>	<input checked="" type="checkbox"/>	
Crystal Effects							
Transparent Effects							
<input type="checkbox"/>	Crystal AB F (001 AB)	<input checked="" type="checkbox"/>	<input checked="" type="checkbox"/>	<input checked="" type="checkbox"/>	<input checked="" type="checkbox"/>	<input checked="" type="checkbox"/>	
<input type="checkbox"/>	Crystal Golden Shadow F (001 GSHA)	<input checked="" type="checkbox"/>	<input checked="" type="checkbox"/>	<input checked="" type="checkbox"/>	<input checked="" type="checkbox"/>	<input checked="" type="checkbox"/>	
<input type="checkbox"/>	Crystal Silver Shade F (001 SSHA)	<input checked="" type="checkbox"/>	<input checked="" type="checkbox"/>	<input checked="" type="checkbox"/>	<input checked="" type="checkbox"/>	<input checked="" type="checkbox"/>	
Metallic Effects							
<input type="checkbox"/>	Crystal Dorado F (001 DOR)	<input checked="" type="checkbox"/>	<input checked="" type="checkbox"/>	<input checked="" type="checkbox"/>	<input checked="" type="checkbox"/>	<input checked="" type="checkbox"/>	
Color Effects							
Metallic Effects							
<input type="checkbox"/>	Jet Hematite F (280 HEM)	<input checked="" type="checkbox"/>	<input checked="" type="checkbox"/>	<input checked="" type="checkbox"/>	<input checked="" type="checkbox"/>	<input checked="" type="checkbox"/>	

* Art. 52 001 is not available with net-edge. When ordering one row with net-edge, art. 52 000 is to be used.

52 500



R	001-024	
SS	PP 24	
M	05 M	100%

52 501*

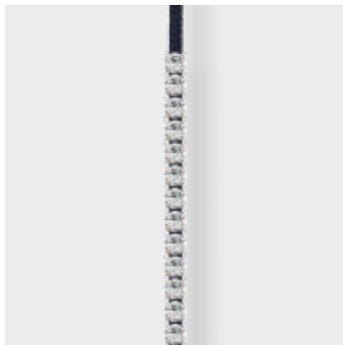

R	001	
SS	PP 24	
M	10 M	100%



	Color of Thread / Net-edge		Color of Casing		
	012 / 112 / 212 Black	022 / 122 / 222 White	081 Gold	082 Silver	086 Gun Metal
Crystal					
Crystal F (001)	■	■	■	■	■
Colors					
Plain Colors					
Black Diamond F (215)	■	■	■	■	■
Dark Moss Green F (260)	■	■	■	■	■
Denim Blue F (266)	■	■	■	■	■
Fuchsia F (502)	■	■	■	■	■
Greige F (284)	■	■	■	■	■
Jet F (280)	■	■	■	■	■
Light Colorado Topaz F (246)	■	■	■	■	■
Light Peach F (362)	■	■	■	■	■
Light Silk F (261)	■	■	■	■	■
Light Turquoise F (263)	■	■	■	■	■
Rose Peach F (262)	■	■	■	■	■
Siam F (208)	■	■	■	■	■
Smoked Topaz F (220)	■	■	■	■	■
Tangerine F (259)	■	■	■	■	■
Crystal Effects					
Transparent Effects					
Crystal AB F (001 AB)	■	■	■	■	■
Crystal Antique Pink F (001 ANTP)	■	■	■	■	■
Crystal Blue Shade F (001 BLSH)	■	■	■	■	■
Crystal Golden Shadow F (001 GSHA)	■	■	■	■	■
Crystal Lilac Shadow F (001 LISH)	■	■	■	■	■
Crystal Luminous Green F (001 LUMG)	■	■	■	■	■
Crystal Silver Night F (001 SINI)	■	■	■	■	■
Crystal Silver Shade F (001 SSHA)	■	■	■	■	■
Metallic Effects					
Crystal Dorado F (001 DOR)	■	■	■	■	■
Crystal Iridescent Green F (001 IRIG)	■	■	■	■	■
Crystal Rose Gold F (001 ROGL)	■	■	■	■	■
Color Effects					
Metallic Effects					
Jet Hematite F (280 HEM)	■	■	■	■	■

* Art. 52 501 is not available with net-edge. When ordering one row with net-edge, art. 52 500 is to be used.

Metal Trimmings

Flat Back Bandings

55 000

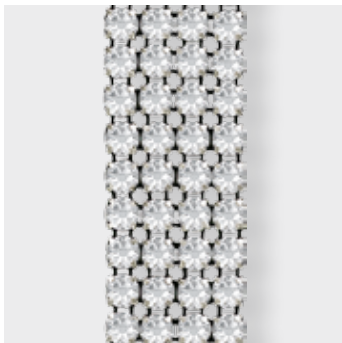

R	001-024	
SS	SS 20	
M	05 M	100%

55 001*

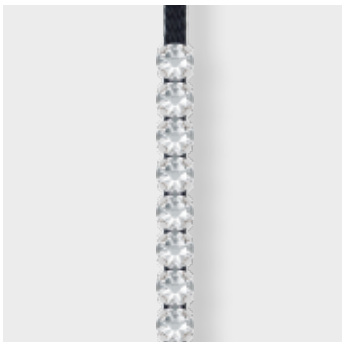

R	001	
SS	SS 20	
M	10 M	100%

	Color of Thread / Net-edge		Color of Casing		
	012 / 112 / 212 Black	022 / 122 / 222 White	081 Gold	082 Silver	086 Gun Metal
Crystal					
Crystal F (001)	■	■	■	■	■
Colors					
Plain Colors					
Black Diamond F (215)	■	■	■	■	■
Dark Moss Green F (260)	■	■	■	■	■
Denim Blue F (266)	■	■	■	■	■
Fuchsia F (502)	■	■	■	■	■
Greige F (284)	■	■	■	■	■
Jet F (280)	■	■	■	■	■
Light Amethyst F (212)	■	■	■	■	■
Light Colorado Topaz F (246)	■	■	■	■	■
Light Silk F (261)	■	■	■	■	■
Light Turquoise F (263)	■	■	■	■	■
Rose Peach F (262)	■	■	■	■	■
Siam F (208)	■	■	■	■	■
Smoked Topaz F (220)	■	■	■	■	■
Tangerine F (259)	■	■	■	■	■
Vintage Rose F (263)	■	■	■	■	■
Opal Colors					
Caribbean Blue Opal F (394)	■	■	■	■	■
Crystal Effects					
Transparent Effects					
Crystal AB F (001 AB)	■	■	■	■	■
Crystal Antique Pink F (001 ANTP)	■	■	■	■	■
Crystal Blue Shade F (001 BLSH)	■	■	■	■	■
Crystal Golden Shadow F (001 GSHA)	■	■	■	■	■
Crystal Lilac Shadow F (001 LISH)	■	■	■	■	■
Crystal Luminous Green F (001 LUMG)	■	■	■	■	■
Crystal Silver Night F (001 SINI)	■	■	■	■	■
Crystal Silver Shade F (001 SSHA)	■	■	■	■	■
Metallic Effects					
Crystal Dorado F (001 DOR)	■	■	■	■	■
Crystal Iridescent Green F (001 IRIG)	■	■	■	■	■
Crystal Rose Gold F (001 ROGL)	■	■	■	■	■
Color Effects					
Metallic Effects					
Jet Hematite F (280 HEM)	■	■	■	■	■

* Art. 55 001 is not available with net-edge. When ordering one row with net-edge, art. 55 000 is to be used.

55 500



R	001-024	
SS	SS 12	
M	10 M	100%

55 501*

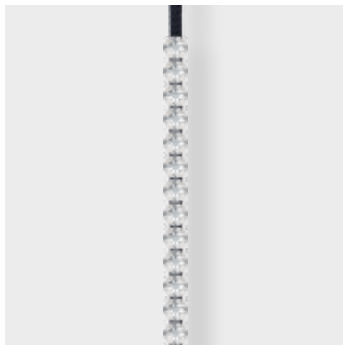

R	001	
SS	SS 12	
M	10 M	100%

	Color of Thread / Net-edge		Color of Casing		
	012 / 112 / 212 Black	022 / 122 / 222 White	081 Gold	082 Silver	086 Gun Metal
Crystal					
Crystal F (001)	■	■	■	■	■
Colors					
Plain Colors					
Black Diamond F (215)	■	■	■	■	■
Dark Moss Green F (260)	■	■	■	■	■
Denim Blue F (266)	■	■	■	■	■
Fuchsia F (502)	■	■	■	■	■
Greige F (284)	■	■	■	■	■
Jet F (280)	■	■	■	■	■
Light Amethyst F (212)	■	■	■	■	■
Light Colorado Topaz F (246)	■	■	■	■	■
Light Silk F (261)	■	■	■	■	■
Light Turquoise F (263)	■	■	■	■	■
Rose Peach F (262)	■	■	■	■	■
Siam F (208)	■	■	■	■	■
Smoked Topaz F (220)	■	■	■	■	■
Tangerine F (259)	■	■	■	■	■
Vintage Rose F (263)	■	■	■	■	■
Opal Colors					
Caribbean Blue Opal F (394)	■	■	■	■	■
Crystal Effects					
Transparent Effects					
Crystal AB F (001 AB)	■	■	■	■	■
Crystal Antique Pink F (001 ANTP)	■	■	■	■	■
Crystal Blue Shade F (001 BLSH)	■	■	■	■	■
Crystal Golden Shadow F (001 GSHA)	■	■	■	■	■
Crystal Lilac Shadow F (001 LISH)	■	■	■	■	■
Crystal Luminous Green F (001 LUMG)	■	■	■	■	■
Crystal Silver Night F (001 SINI)	■	■	■	■	■
Crystal Silver Shade F (001 SSHA)	■	■	■	■	■
Metallic Effects					
Crystal Dorado F (001 DOR)	■	■	■	■	■
Crystal Iridescent Green F (001 IRIG)	■	■	■	■	■
Crystal Rose Gold F (001 ROGL)	■	■	■	■	■
Color Effects					
Metallic Effects					
Jet Hematite F (280 HEM)	■	■	■	■	■

* Art. 55 501 is not available with net-edge. When ordering one row with net-edge, art. 55 500 is to be used.

ARTICLE EXPLANATION

52 300



R	001-024
SS	SS 18
M	05 M
	100%

52 300	R	SS	M	100%
Article number	Number of rows	Stone size	Minimum order quantity in meters (M)	Documentation size in %
	This article is available from 1 to 24 rows			

ORDERING EXAMPLE & PRODUCT VARIETY EXPLANATION

52 300	001	012	082	001
Article number	3-digit code for number of rows	Color of thread (without net-edge, on 1 side/2 sides): 012 Black (without net-edge) 022 White (without net-edge) 112 Black (on 1 side) 212 Black (on 2 sides) 122 White (on 1 side) 222 White (on 2 sides)	Color of casing 081 Gold 082 Silver 086 Gun Metal	Color of crystals Please see the respective product matrix for all available code references.

Metal Trimmings

Spike Bandings

52 300



R	001-024	
SS	SS 18	
M	05 M	100%

52 301*

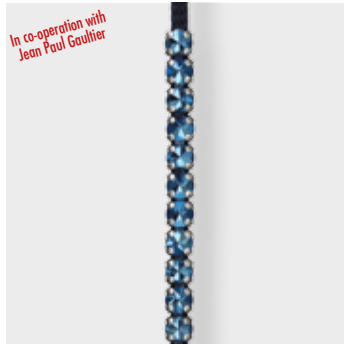

R	001	
SS	SS 18	
M	10 M	100%

52 400

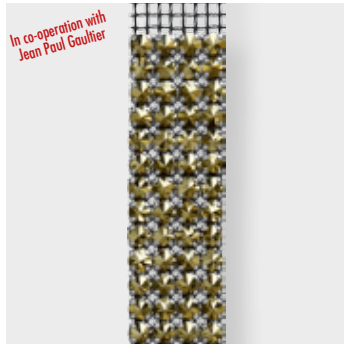

R	001-024	
SS	PP 24	
M	05 M	100%

52 401*

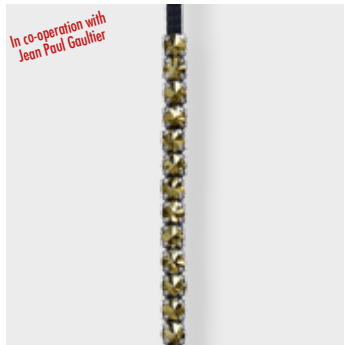

R	001	
SS	PP 24	
M	10 M	100%

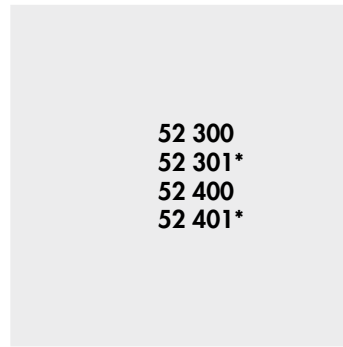

	Color of Thread / Net-edge	012 / 112 / 212 Black	022 / 122 / 222 White	Color of Casing	081 Gold	082 Silver	086 Gun Metal
Crystal Effects							
Metallic Effects							
Crystal Chrom (001 CHR)							
Crystal Dorado (001 DOR)							
Crystal Metallic Blue (001 METBL)							
Crystal Metallic Light Gold (001 MLGLD)							
Crystal Rose Gold (001 ROGL)							
Color Effects							
Metallic Effects							
Jet Hematite (280 HEM)							
Jet Nut (280 NUT)							

* Art. 52 301 and 52 401 are not available with net-edge. When ordering one row with net-edge, art. 52 300 (for 52 301) or 52 400 (for 52 401) is to be used.

ARTICLE EXPLANATION

52 114

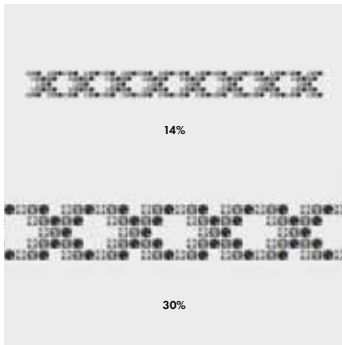

C	086-280HEM/215/001
E	CH SS18/SS18/SS18
S	~280x25
M	10 PCS

52 114	C	E	S	M	40%
Article number	Color assortment	Elements and stone sizes	Motif size in mm without net-edge	Minimum order quantity in pieces (PCS)	Documentation size in %
		This product is a Chaton Motif (CH). For details please refer to the sizes overview at the end of this Collection.	Slight size deviations may occur, +/- 2% or +/- 8% depending on the motif		

ORDERING EXAMPLE & PRODUCT VARIETY EXPLANATION

52 114	001	422	086	280 HEM
Article number	3-digit code for number of rows	Color of thread & net-edge	Color of casing	Crystal color corresponding to element 1; color of most frequently used element in the motif. Please see the respective product matrix for all available code references.
	Always 001	Chaton Motifs by piece. Chaton Motifs by meter. Please see the respective product tables for all available net-edge options.	081 Gold 082 Silver 086 Gun Metal	
>>	215	001		
	Crystal color corresponding to element 2; color of second most frequently used element in the motif	Crystal color corresponding to element 3; color of third most frequently used element in the motif		

AVAILABLE OPTIONS WITH NET-EDGE

Depending on the motif, Chaton and Flat Back Motifs can be ordered with net-edge on 0, 1, 2, 3 or 4 sides.* Please see the respective product matrix for all available options and tolerances.



122
White net-edge
on one side



322
White net-edge
on three sides



222
White net-edge
on two sides



422
White net-edge
on four sides

AVAILABLE THREAD / NET-EDGE & CASING COLORS

Chaton and Flat Back Motifs are available in three different casing colors and can be combined with two different thread/net-edge colors. Please see the respective product matrix for all available options.

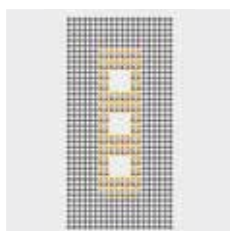

412 081
Black thread
& net-edge
on four sides,
gold casing

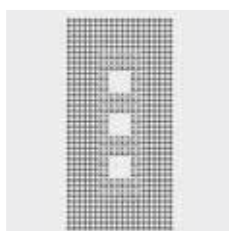

412 086
Black thread
& net-edge
on four sides,
gun metal
casing

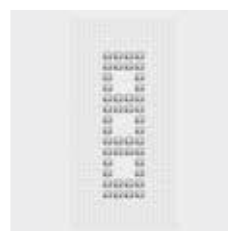

422 082
White thread
& net-edge
on four sides,
silver casing

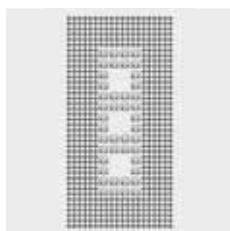

412 082
Black thread
& net-edge
on four sides,
silver casing



422 081
White thread
& net-edge
on four sides,
gold casing

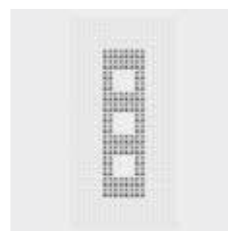

422 086
White thread
& net-edge
on four sides,
gun metal
casing

* Please note: depending on the motif, Chaton and Flat Back Motifs by the metre are only available with net-edge on none, one or two sides.

52 100 to 52 608		Color of Thread / Netedge		Color of Casing		
		012 / 112 / 212 Black	022 / 122 / 222 White	081 Gold	082 Silver	086 Gun Metal
Crystal						
Crystal F (001)		■	■	■	■	■
Colors						
Plain Colors						
Black Diamond F (215)		■	■	■	■	■
Dark Moss Green F (260)*		■	■	■	■	■
Denim Blue F (266)*		■	■	■	■	■
Fuchsia F (502)		■	■	■	■	■
Greige F (284)		■	■	■	■	■
Jet F (280)		■	■	■	■	■
Light Colorado Topaz F (246)		■	■	■	■	■
Light Peach F (362)		■	■	■	■	■
Light Silk F (261)*		■	■	■	■	■
Light Turquoise F (263)*		■	■	■	■	■
Rose Peach F (262)*		■	■	■	■	■
Siam F (208)		■	■	■	■	■
Smoked Topaz F (220)		■	■	■	■	■
Tangerine F (259)*		■	■	■	■	■
Crystal Effects						
Transparent Effects						
Crystal AB F (001 AB)		■	■	■	■	■
Crystal Antique Pink F (001 API)*		■	■	■	■	■
Crystal Blue Shade F (001 BLSH)*		■	■	■	■	■
Crystal Golden Shadow F (001 GSHA)		■	■	■	■	■
Crystal Lilac Shadow F (001 LISH)*		■	■	■	■	■
Crystal Luminous Green F (001 LUMG)*		■	■	■	■	■
Crystal Silver Night F (001 SINI)*		■	■	■	■	■
Crystal Silver Shade F (001 SSHA)		■	■	■	■	■
Metallic Effects						
Crystal Dorado F (001 DOR)		■	■	■	■	■
Crystal Iridescent Green F (001 IRIG)*		■	■	■	■	■
Crystal Rose Gold F (001 ROGL)*		■	■	■	■	■
Color Effects						
Metallic Effects						
Jet Hematite F (280 HEM)		■	■	■	■	■

* only available for store size PP 24



52 114

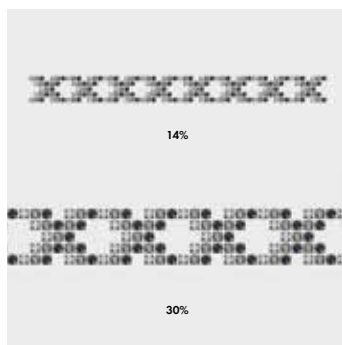

C 086-280HEM/215/001
 E CH SS18/SS18/SS18
 S ~280x25
 M 10 PCS

52 204

02

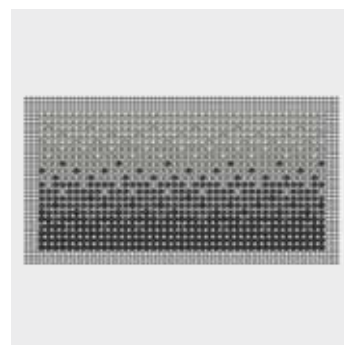

C 086-280/280HEM/215/001SSHA
 E CH PP24/PP24/PP24/PP24
 S ~189x92
 M 10 PCS | 20%

52 609

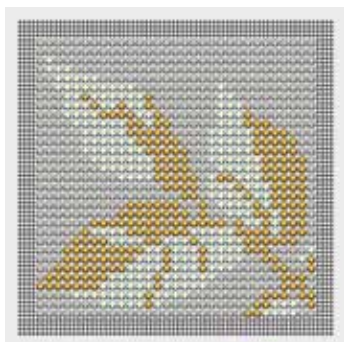

C 082-001SSHA/001IRIG/001DOR
 E CH PP24/PP24/PP24
 S ~105X105 (EXCL. NET-EDGE)
 M 10 PCS | 35%

52 610

02

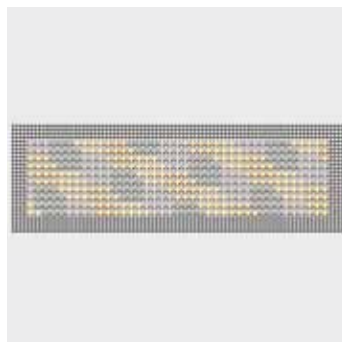

C 082-284/001ROGL/001SSHA/001GSHA
 E CH PP24/PP24/PP24/PP24
 S ~133x34
 M 10 PCS | 30%

AVAILABLE OPTIONS WITH NET-EDGE

Article Number	1 Side	2 Sides	3 Sides	4 Sides	Tolerance
52 114	112 Black / 122 White	212 Black / 222 White	312 Black / 322 White	412 Black / 422 White	+/- 8%
52 204	112 Black / 122 White	212 Black / 222 White	312 Black / 322 White	412 Black / 422 White	+/- 8%
52 609	112 Black / 122 White	212 Black / 222 White	312 Black / 322 White	412 Black / 422 White	+/- 8%
52 610	112 Black / 122 White	212 Black / 222 White	312 Black / 322 White	412 Black / 422 White	+/- 8%

55 100 to 55 618		Color of Thread / Netedge		012 / 112 / 212 Black	022 / 122 / 222 White	Color of Casing		081 Gold	082 Silver	086 Gun Metal
Crystal										
Colors										
Plain Colors										
Crystal F (001)				■	■	■	■	■	■	■
Plain Colors										
Black Diamond F (215)				■	■	■	■	■	■	■
Dark Moss Green F (260)				■	■	■	■	■	■	■
Denim Blue F (266)				■	■	■	■	■	■	■
Fuchsia F (502)				■	■	■	■	■	■	■
Greige F (284)				■	■	■	■	■	■	■
Jet F (280)				■	■	■	■	■	■	■
Light Amethyst F (212)				■	■	■	■	■	■	■
Light Colorado Topaz F (246)				■	■	■	■	■	■	■
Light Silk F (261)				■	■	■	■	■	■	■
Light Turquoise F (263)				■	■	■	■	■	■	■
Rose Peach F (262)				■	■	■	■	■	■	■
Siam F (208)				■	■	■	■	■	■	■
Smoked Topaz F (220)				■	■	■	■	■	■	■
Tangerine F (259)				■	■	■	■	■	■	■
Vintage Rose F (263)				■	■	■	■	■	■	■
Opal Colors										
Caribbean Blue Opal F (394)				■	■	■	■	■	■	■
Crystal Effects										
Transparent Effects										
Crystal AB F (001 AB)				■	■	■	■	■	■	■
Crystal Antique Pink F (001 ANTP)				■	■	■	■	■	■	■
Crystal Blue Shade F (001 BLSH)				■	■	■	■	■	■	■
Crystal Golden Shadow F (001 GSHA)				■	■	■	■	■	■	■
Crystal Lilac Shadow F (001 LISH)				■	■	■	■	■	■	■
Crystal Luminous Green F (001 LUMG)				■	■	■	■	■	■	■
Crystal Silver Night F (001 SINI)				■	■	■	■	■	■	■
Crystal Silver Shade F (001 SSHA)				■	■	■	■	■	■	■
Metallic Effects										
Crystal Dorado F (001 DOR)				■	■	■	■	■	■	■
Crystal Iridescent Green F (001 IRIG)				■	■	■	■	■	■	■
Crystal Rose Gold F (001 ROGL)				■	■	■	■	■	■	■
Color Effects										
Metallic Effects										
Jet Hematite F (280 HEM)				■	■	■	■	■	■	■

Metal Trimmings

Flat Back Motifs

Standard Collection



55 126 **02**

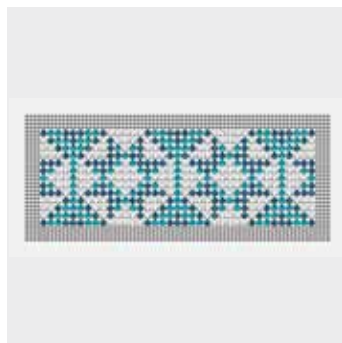

C	082-001/266/263
E	FB SS20/SS20/SS20
S	~182x64 (EXCL. NET-EDGE)
M	10 PCS 20%

55 127 **02**



C	086-280/215/220/246/208/001GSHA/ 280HEM/001SINI
E	FB SS20
S	~231x80 (EXCL. NET-EDGE)
M	10 PCS 17%

55 616



C	082-001BLSH/263/266/280HEM/280
E	SS12/SS12/SS12/SS12/SS12
S	~196x59 (EXCL. NET-EDGE)
M	10 PCS 20%

55 619 **02**

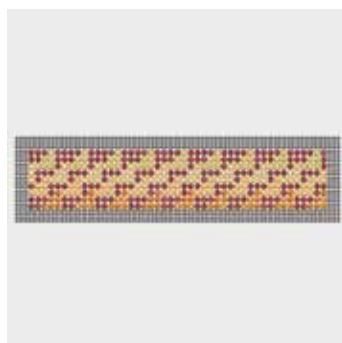

C	081-001LISH/001LUMG/261/001GSHA/ 001ROGL
E	SS12/SS12/SS12/SS12/SS12
S	~157x31 (EXCL. NET-EDGE)
M	10 PCS 25%

55 621 **02**



C	081-261/502/260/208
E	FB SS12/SS12/SS12/SS12
S	~164x59 (EXCL. NET-EDGE)
M	10 PCS 24%



55 620

04



C	086-001ROGL/280/001SSHA/246	
E	SS12/SS12/SS12/SS12	
S	~31x73 (EXCL. NET-EDGE)	
M	10 PCS	45%

AVAILABLE OPTIONS WITH NET-EDGE

Article Number	1 Side	2 Sides	3 Sides	4 Sides	Tolerance
55 126	112 Black / 122 White	212 Black / 222 White	312 Black / 322 White	412 Black / 422 White	+/- 8%
55 127				412 Black / 422 White	+/- 8%
55 616	112 Black / 122 White	212 Black / 222 White	312 Black / 322 White	412 Black / 422 White	+/- 8%
55 619	112 Black / 122 White	212 Black / 222 White	312 Black / 322 White	412 Black / 422 White	+/- 8%
55 621	112 Black / 122 White	212 Black / 222 White	312 Black / 322 White	412 Black / 422 White	+/- 8%

SPECIAL MOTIF SERVICE

A special motif is any individual design created by the customer, which is different from the Metal Trimmings Standard or Crystal Inspirations Collection. This service opens up many customization possibilities and enables you to profit from Swarovski's longtime experience and design expertise. A range of customization options for existing motifs is available (see "Customization Possibilities" below). You may also submit sketches of a design that will suit your special needs – such as a brand image or an image to suit a particular sales campaign. This will then be made up according to your specifications using Computer Aided Design, which allows for easy adjustments according to your needs.

CUSTOMIZATION POSSIBILITIES

- Change of size of an existing motif
- Logos or brand names
- Creation of pieces or rows
- Up to nine colors/elements possible per Metal Trimming
- For thread- and net-edge options please see the respective matrix for all available options.

ORDERING PROCESS

Send the request with a drawing you wish to order to your nearest Swarovski sales office. Make sure you include all measurements to the desired motif. Please also indicate which product group your special motif refers to (Flat Back Motifs, Chaton Motifs etc.). You will then receive a quotation including your article number, minimum order quantity, price, and the line drawing of your special motif in PDF format. Please contact your Swarovski sales office again if any changes need to be made. Your special motif will be produced and delivered following your confirmation.

PLEASE NOTE

Please always submit your drawing of the desired motif to represent it in the actual size you require. A small sketch, when enlarged to the desired size, will have blurred lines that will make it difficult to correctly reinterpret. Pictures or drawings representing 100% size of the design or very good quality scans in JPG, BMP or DXF format will ensure that we have clear data to work with. These can also be sent via email or on a CD-ROM. If sending a sewing pattern, please include the whole pattern and not just cut outs. When the sketch is submitted as a hard copy by fax or e-mail, please include a scale legend (e.g. copy/scan with ruler next to the drawing). This will ensure that the desired size of the motif can be identified.

Special productions are generally offered to all our customers if feasibility is given and our General Terms and Conditions are applied. Please note that the simple order of a design does not grant exclusive production of this design to the customer.

ARTICLE EXPLANATION

53 000



SS SS 18	
M 1,000 PCS	100%

53 000	SS	M	100%
Article number	Stone size	Minimum order quantity in pieces (PCS)	Documentation size in %

ORDERING EXAMPLE & PRODUCT VARIETY EXPLANATION

53 000	082	001
Article number	Color of casing	Color of crystals
	081 Gold 082 Silver 086 Gun Metal 088 Stainless Steel	Please see the respective product matrix for all available code references.

Please note that the Back Parts for Rivets have to be ordered separately. Please see the respective product matrix for all available Back Parts on page 605.

Metal Trimmings

Metal Components

Rivets

53 000 Rivets



SS SS 18	
M 1,000 PCS	100%

53 002* Rivets

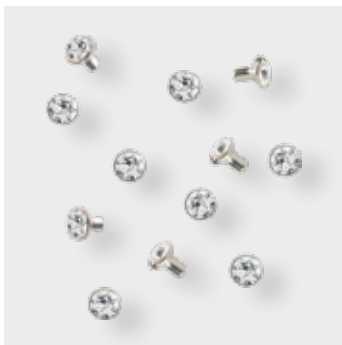

SS SS 18	
M 1,000 PCS	100%

	Color of Casing			
	081 Gold	082 Silver	086 Gun Metal	088 Stainless Steel
53 000 53 002**				
Crystal				
Crystal F (001)	■	■	■	■
Colors				
Plain Colors				
Amethyst F (204)	■	■	■	■
Black Diamond F (215)	■	■	■	■
Dark Indigo F (288)	■	■	■	■
Fuchsia F (502)	■	■	■	■
Greige F (284)	■	■	■	■
Jet F (280)	■	■	■	■
Light Colorado Topaz F (246)	■	■	■	■
Light Siam F (227)	■	■	■	■
Peridot F (214)	■	■	■	■
Rose F (209)	■	■	■	■
Sapphire F (206)	■	■	■	■
Siam F (208)	■	■	■	■
Smoked Topaz F (220)	■	■	■	■
Topaz F (203)	■	■	■	■
Vintage Rose F (319)	■	■	■	■
Crystal Effects				
Transparent Effects				
Crystal AB F (001 AB)	■	■	■	■
Crystal Golden Shadow F (001 GSHA)	■	■	■	■
Crystal Silver Shade F (001 SSHA)	■	■	■	■

* Please note that art. 53 002 was especially developed for an application without back part.

** Please note that art. 53 002 is not available in Stainless Steel.

53 001 Rivets



SS SS 29	
M 500 PCS	100%

53 005 Rivets



SS SS 34	
M 500 PCS	100%

53 006 Rivets

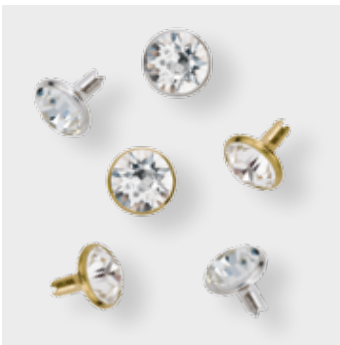

SS SS 39	
M 300 PCS	100%

53 001*
53 005*
53 006*

Color of Casing	081 Gold	082 Silver	086 Gun Metal	088 Stainless Steel
-----------------	----------	------------	---------------	---------------------

Crystal	081 Gold	082 Silver	086 Gun Metal	088 Stainless Steel
Crystal				
Crystal F (001)	■	■	■	■
Colors				
Plain Colors				
Amethyst F (204)	■	■	■	■
Black Diamond F (215)	■	■	■	■
Dark Indigo F (288)	■	■	■	■
Dark Moss Green F (260)	■	■	■	■
Denim Blue F (266)	■	■	■	■
Fuchsia F (502)	■	■	■	■
Greige F (284)	■	■	■	■
Jet F (280)	■	■	■	■
Light Colorado Topaz F (246)	■	■	■	■
Light Siam F (227)	■	■	■	■
Light Silk F (261)	■	■	■	■
Light Turquoise F (263)	■	■	■	■
Peridot F (214)	■	■	■	■
Rose F (209)	■	■	■	■
Sapphire F (206)	■	■	■	■
Siam F (208)	■	■	■	■
Smoked Topaz F (220)	■	■	■	■
Tangerine F (259)	■	■	■	■
Topaz F (203)	■	■	■	■
Vintage Rose F (319)	■	■	■	■
Crystal Effects				
Transparent Effects				
Crystal AB F (001 AB)	■	■	■	■
Crystal Blue Shade F (001 BLSH)	■	■	■	■
Crystal Golden Shadow F (001 GSHA)	■	■	■	■
Crystal Lilac Shadow F (001 LISH)	■	■	■	■
Crystal Luminous Green F (001 LUMG)	■	■	■	■
Crystal Silver Night F (001 SINI)	■	■	■	■
Crystal Silver Shade F (001 SSHA)	■	■	■	■
Metallic Effects				
Crystal Iridescent Green F (001 IRIG)	■	■	■	■
Crystal Rose Gold F (001 ROGL)	■	■	■	■

* For respective Back Parts please refer to the chapter "Metal Trimmings" on page 605.

53 008 Rivets

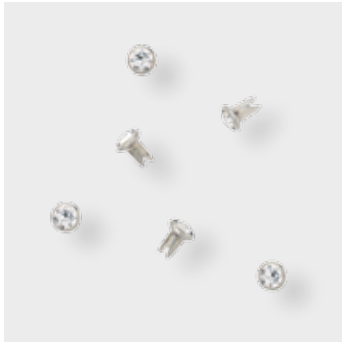

SS PP 24	
M 500 PCS	100%

53 008*

Color of Casing

088 Stainless Steel

Crystal

Crystal F (001)

Colors

Plain Colors

Amethyst F (204)

Black Diamond F (215)

Dark Indigo F (288)

Dark Moss Green F (260)

Denim Blue F (266)

Fuchsia F (502)

Greige F (284)

Jet F (280)

Light Colorado Topaz F (246)

Light Siam F (227)

Light Silk F (261)

Light Turquoise F (263)

Peridot F (214)

Rose F (209)

Sapphire F (206)

Siam F (208)

Smoked Topaz F (220)

Tangerine F (259)

Topaz F (203)

Vintage Rose F (319)

Crystal Effects

Transparent Effects

Crystal AB F (001 AB)

Crystal Blue Shade F (001 BLSH)

Crystal Golden Shadow F (001 GSHA)

Crystal Lilac Shadow F (001 LISH)

Crystal Luminous Green F (001 LUMG)

Crystal Silver Night F (001 SINI)

Crystal Silver Shade F (001 SSHA)

Metallic Effects

Crystal Iridescent Green F (001 IRIG)

Crystal Rose Gold F (001 ROGL)

* For respective Back Parts please refer to the chapter "Metal Trimmings" on page 605.

53 400 Crystal Pearl Rivets



SS 6 mm	
M 500 PCS	100%

53 401 Crystal Pearl Rivets



SS 8 mm	
M 300 PCS	100%

53 402 Crystal Pearl Rivets



SS 10 mm	
M 300 PCS	100%

53 400
53 401
53 402

Color of Casing	081 Gold	082 Silver	086 Gun Metal
Colors			
<input type="checkbox"/> Crystal Bronze Pearl (001 295)	■	■	■
<input type="checkbox"/> Crystal Cream Pearl (001 620)	■	■	■
<input type="checkbox"/> Crystal Light Creamrose Pearl (001 618)	■	■	■
<input type="checkbox"/> Crystal Grey Pearl (001 731)	■	■	■
<input type="checkbox"/> Crystal Rose Gold Pearl (001 769)	■	■	■
<input type="checkbox"/> Crystal White Pearl (001 650)	■	■	■
Gemcolors			
<input type="checkbox"/> Crystal Ivory Pearl (001 708)	■	■	■
<input type="checkbox"/> Crystal Mystic Black Pearl (001 335)	■	■	■

* For respective Back Parts please refer to the chapter "Metal Trimmings" on page 605.

53 500 Square Rivets

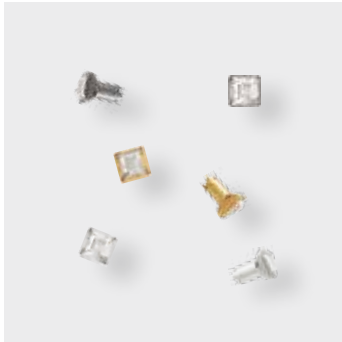

SS 4 mm
M 500 PCS 100%

53 501 Square Rivets

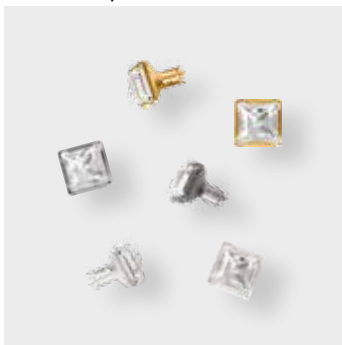

SS 6 mm
M 300 PCS 100%

53 502 Square Rivets

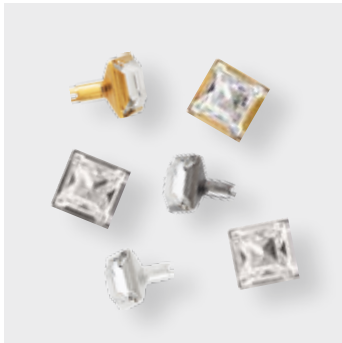

SS 8 mm
M 300 PCS 100%

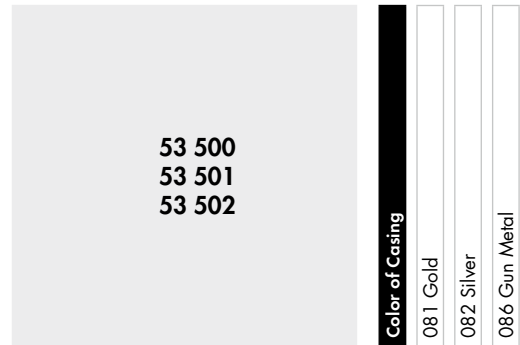

	Color of Casing		
	081 Gold	082 Silver	086 Gun Metal
Crystal			
Crystal F (001)	■	■	■
Colors			
Plain Colors			
Amethyst F (204)	■	■	■
Black Diamond F (215)	■	■	■
Dark Moss Green F (260)	■	■	■
Denim Blue F (266)	■	■	■
Fuchsia F (502)	■	■	■
Greige F (284)	■	■	■
Jet F (280)	■	■	■
Light Colorado Topaz F (246)	■	■	■
Light Silk F (261)	■	■	■
Light Turquoise F (263)	■	■	■
Rose F (209)	■	■	■
Rose Peach F (262)	■	■	■
Siam F (208)	■	■	■
Smoked Topaz F (220)	■	■	■
Tangerine F (259)	■	■	■
Crystal Effects			
Transparent Effects			
Crystal AB F (001 AB)	■	■	■
Crystal Antique Pink F (001 ANTP)	■	■	■
Crystal Blue Shade F (001 BLSH)	■	■	■
Crystal Golden Shadow F (001 GSHA)	■	■	■
Crystal Lilac Shadow F (001 LISH)	■	■	■
Crystal Luminous Green F (001 LUMG)	■	■	■
Crystal Silver Shade F (001 SSHA)	■	■	■
Metallic Effects			
Crystal Iridescent Green F (001 IRIG)	■	■	■
Crystal Rose Gold F (001 ROGL)	■	■	■

* For respective Back Parts please refer to the chapter "Metal Trimmings" on page 605.

53 600 Chessboard Rivets



SS 6 mm	
M 300 PCS	100%

53 600		Color of Casing		
		081 Gold	082 Silver	086 Gun Metal
Crystal				
Crystal F (001)				
Colors				
Plain Colors				
Aquamarine F (202)				
Black Diamond F (215)				
Jet F (280)				
Crystal Effects				
Transparent Effects				
Crystal AB F (001 AB)				
Crystal Antique Pink F (001 ANTP)				
Crystal Golden Shadow F (001 GSHA)				
Crystal Red Magma F (001 REDM)				

* For respective Back Parts please refer to the chapter "Metal Trimmings" on page 605.

53 700 Star Rivets

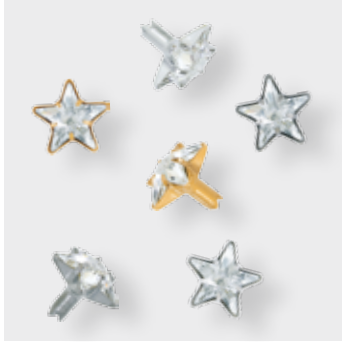

SS	10 mm	
M	300 PCS	100%

53 700		Color of Casing		
		081 Gold	082 Silver	086 Gun Metal
Crystal				
Crystal F (001)				
Colors				
Plain Colors				
Jet F (280)				
Crystal Effects				
Transparent Effects				
Crystal AB F (001 AB)				
Crystal Bermuda Blue F (001 BBL)				
Crystal Golden Shadow F (001 GSHA)				
Crystal Silver Shade F (001 SSHA)				
Crystal Vitrail Light F (001 VL)				
Crystal Vitrail Medium F (001 VM)				
Color Effects				
Metallic Effects				
Jet Hematite F (280 HEM)				

* For respective Back Parts please refer to the chapter "Metal Trimmings" on page 605.

53 010 Spike Rivets

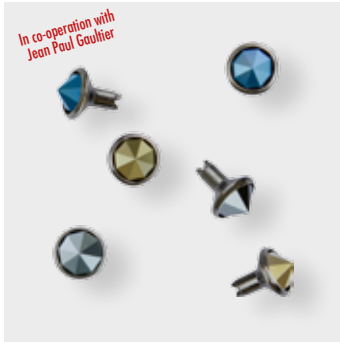

SS SS 29	
M 144 PCS	100%

53 011 Spike Rivets



SS SS 39	
M 144 PCS	100%

53 503 Spike Rivets



SS 8 mm	
M 144 PCS	100%

53 010 53 011 53 503	Color of Casing	081 Gold	082 Silver	086 Gun Metal
Crystal Effects				
Metallic Effects				
Crystal Chrom (001 CHRM)				
Crystal Dorado (001 DOR)				
Crystal Metallic Blue (001 METBL)				
Crystal Metallic Light Gold (001 MLGLD)				
Crystal Rose Gold (001 ROGL)				
Color Effects				
Metallic Effects				
Jet Hematite (280 HEM)				
Jet Nut (280 NUT)				

* For respective Back Parts please refer to the chapter "Metal Trimmings" on page 605.

53 007



M 1,000 PCS | 100%

53 009



M 1,000 PCS | 100%

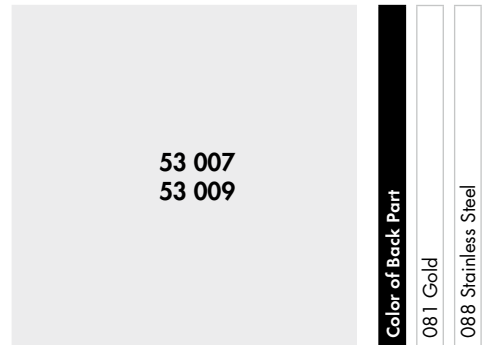

53 007
53 009

Color of Back Part

081 Gold

088 Stainless Steel

Rivets (Color of Casing)

53 000 (081/082/086)	■	■
53 000 (088)	■	■
53 001 (081/082/086)	■	■
53 001 (088)	■	■
53 005 (081/082/086)	■	■
53 005 (088)	■	■
53 006 (081/082/086)	■	■
53 006 (088)	■	■
53 008 (088)	■	■
53 010 (081/082/086)	■	■
53 011 (081/082/086)	■	■
53 400 (081/082/086)	■	■
53 401 (081/082/086)	■	■
53 402 (081/082/086)	■	■
53 500 (081/082/086)	■	■
53 501 (081/082/086)	■	■
53 502 (081/082/086)	■	■
53 503 (081/082/086)	■	■
53 600 (081/082/086)	■	■
53 700 (081/082/086)	■	■

ORDERING EXAMPLE & PRODUCT VARIETY EXPLANATION

53 007

Article number

081

Color of casing

081 Gold

088 Stainless Steel

53 100 Rose Montées



SS SS 12
M 1,440 PCS 100%

53 102 Rose Montées



SS SS 16
M 1,440 PCS 100%

53 103 Rose Montées



SS SS 30
M 720 PCS 100%

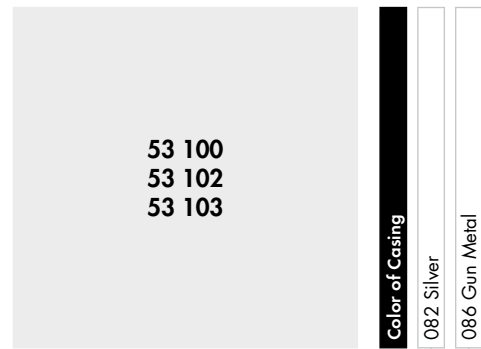

	Color of Casing	082 Silver	086 Gun Metal
Crystal			
Crystal F (001)		<input checked="" type="checkbox"/>	<input checked="" type="checkbox"/>
Colors			
Plain Colors			
Amethyst F (204)		<input checked="" type="checkbox"/>	<input checked="" type="checkbox"/>
Black Diamond F (215)		<input checked="" type="checkbox"/>	<input checked="" type="checkbox"/>
Dark Moss Green F (260)		<input checked="" type="checkbox"/>	<input checked="" type="checkbox"/>
Dark Indigo F (288)		<input checked="" type="checkbox"/>	<input checked="" type="checkbox"/>
Denim Blue F (266)		<input checked="" type="checkbox"/>	<input checked="" type="checkbox"/>
Fuchsia F (502)		<input checked="" type="checkbox"/>	<input checked="" type="checkbox"/>
Greige F (284)		<input checked="" type="checkbox"/>	<input checked="" type="checkbox"/>
Jet F (280)		<input checked="" type="checkbox"/>	<input checked="" type="checkbox"/>
Light Colorado Topaz F (246)		<input checked="" type="checkbox"/>	<input checked="" type="checkbox"/>
Light Siam F (227)		<input checked="" type="checkbox"/>	<input checked="" type="checkbox"/>
Light Silk F (261)		<input checked="" type="checkbox"/>	<input checked="" type="checkbox"/>
Light Turquoise F (263)		<input checked="" type="checkbox"/>	<input checked="" type="checkbox"/>
Peridot F (214)		<input checked="" type="checkbox"/>	<input checked="" type="checkbox"/>
Rose F (209)		<input checked="" type="checkbox"/>	<input checked="" type="checkbox"/>
Sapphire F (206)		<input checked="" type="checkbox"/>	<input checked="" type="checkbox"/>
Siam F (208)		<input checked="" type="checkbox"/>	<input checked="" type="checkbox"/>
Tangerine F (259)		<input checked="" type="checkbox"/>	<input checked="" type="checkbox"/>
Topaz F (203)		<input checked="" type="checkbox"/>	<input checked="" type="checkbox"/>
Vintage Rose F (319)		<input checked="" type="checkbox"/>	<input checked="" type="checkbox"/>
Crystal Effects			
Transparent Effects			
Crystal AB F (001 AB)		<input checked="" type="checkbox"/>	<input checked="" type="checkbox"/>
Crystal Blue Shade F (001 BLSH)		<input checked="" type="checkbox"/>	<input checked="" type="checkbox"/>
Crystal Golden Shadow F (001 GSHA)		<input checked="" type="checkbox"/>	<input checked="" type="checkbox"/>
Crystal Lilac Shadow F (001 LISH)		<input checked="" type="checkbox"/>	<input checked="" type="checkbox"/>
Crystal Luminous Green F (001 LUMG)		<input checked="" type="checkbox"/>	<input checked="" type="checkbox"/>
Crystal Silver Night F (001 SINI)		<input checked="" type="checkbox"/>	<input checked="" type="checkbox"/>
Crystal Silver Shade F (001 SSHA)		<input checked="" type="checkbox"/>	<input checked="" type="checkbox"/>
Metallic Effects			
Crystal Iridescent Green F (001 IRIG)		<input checked="" type="checkbox"/>	<input checked="" type="checkbox"/>
Crystal Rose Gold F (001 ROGL)		<input checked="" type="checkbox"/>	<input checked="" type="checkbox"/>

53 200 Chaton Montées

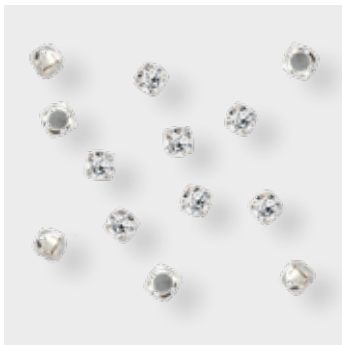

SS PP 31
M 1,440 PCS 100%

53 201 Chaton Montées

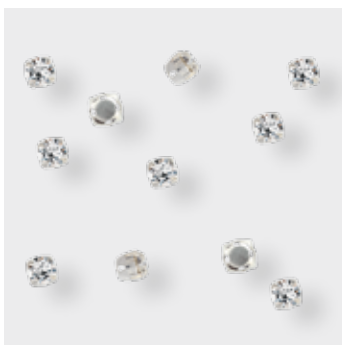

SS SS 18
M 1,440 PCS 100%

53 203 Chaton Montées

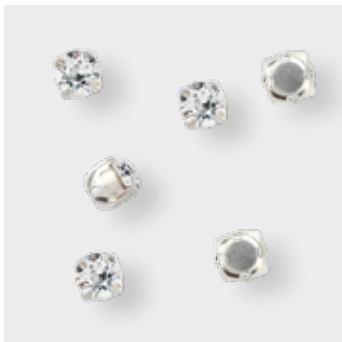

SS SS 29
M 720 PCS 100%

53 200
53 201
53 203

Color of Casing
082 Silver
086 Gun Metal

Crystal	082 Silver	086 Gun Metal
Crystal F (001)	■	■
Colors		
Plain Colors		
Amethyst F (204)	■	■
Black Diamond F (215)	■	■
Dark Indigo F (288)	■	■
Dark Moss Green F (260)*	■	■
Denim Blue F (266)*	■	■
Fuchsia F (502)	■	■
Greige F (284)	■	■
Jet F (280)	■	■
Light Colorado Topaz F (246)	■	■
Light Siam F (227)	■	■
Light Silk F (261)*	■	■
Light Turquoise F (263)*	■	■
Peridot F (214)	■	■
Rose F (209)	■	■
Sapphire F (206)	■	■
Siam F (208)	■	■
Smoked Topaz F (220)	■	■
Tangerine F (259)*	■	■
Topaz F (203)	■	■
Vintage Rose F (319)	■	■
Crystal Effects		
Transparent Effects		
Crystal AB F (001 AB)	■	■
Crystal Blue Shade F (001 BLSH)*	■	■
Crystal Golden Shadow F (001 GSHA)	■	■
Crystal Lilac Shadow F (001 LISH)*	■	■
Crystal Luminous Green F (001 LUMG)*	■	■
Crystal Silver Night F (001 SINI)*	■	■
Crystal Silver Shade F (001 SSHA)	■	■
Metallic Effects		
Crystal Iridescent Green F (001 IRIG)*	■	■
Crystal Rose Gold F (001 ROGL)*	■	■

* These colors are not available for art. 53 201.

53 301 Rose Pins

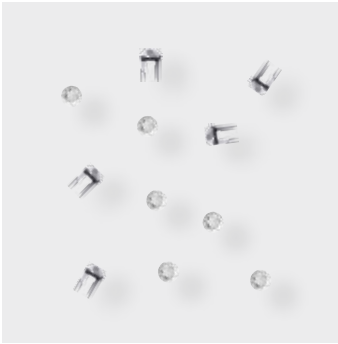

SS SS 10
M 1,440 PCS 100%

53 302 Rose Pins



SS SS 16
M 1,440 PCS 100%

53 303 Rose Pins



SS SS 20
M 720 PCS 100%

53 304 Rose Pins



SS SS 34
M 288 PCS 100%

53 301
53 302
53 303
53 304

Color of Casing
088 Stainless Steel

- Crystal**
- Crystal F (001)
- Colors**
- Plain Colors**
- Black Diamond F (215)
- Denim Blue F (266)
- Fern Green F (291)
- Greige F (284)
- Jet F (280)
- Khaki F (550)
- Light Colorado Topaz F (246)
- Light Siam F (227)
- Peridot F (214)
- Rose F (209)
- Sapphire F (206)
- Smoked Topaz F (220)
- Vintage Rose F (319)
- Crystal Effects**
- Transparent Effects**
- Crystal AB F (001 AB)
- Crystal Antique Pink F (001 ANTP)
- Crystal Blue Shade F (001 BLSH)
- Crystal Golden Shadow F (001 GSHA)
- Crystal Lilac Shadow F (001 LISH)
- Crystal Luminous Green F (001 LUMG)
- Crystal Silver Night F (001 SINI)
- Crystal Silver Shade F (001 SSHA)
- Metallic Effects**
- Crystal Iridescent Green F (001 IRIG)
- Crystal Metallic Light Gold F (001 MLGLD)
- Crystal Rose Gold F (001 ROGL)
- Color Effects**
- Metallic Effects**
- Jet Hematite F (280 HEM)
- Jet Nut F (280 NUT)

53 310 Chessboard Pin

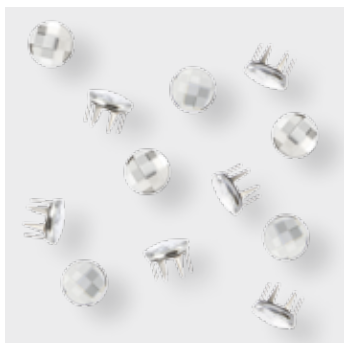

SS 6 mm
M 288 PCS 100%

53 311 Chessboard Pin



SS 10 mm
M 72 PCS 100%

53 320 Rhombus Pin



SS 10x6 mm
M 288 PCS 100%

53 310
53 311

Color of Casing
088 Stainless Steel

- Crystal**
- Crystal F (001)
- Colors**
- Plain Colors**
- Aquamarine F (202)
- Black Diamond F (215)
- Jet F (280)
- Peridot F (214)
- Topaz F (203)
- Crystal Effects**
- Transparent Effects**
- Crystal AB F (001 AB)
- Crystal Dorado F (001 DOR)
- Crystal Golden Shadow F (001 GSHA)
- Crystal Silver Shade F (001 SSHA)

53 320

Color of Casing
088 Stainless Steel

- Crystal**
- Crystal F (001)
- Colors**
- Plain Colors**
- Aquamarine F (202)
- Black Diamond F (215)
- Jet F (280)
- Light Rose F (223)
- Light Siam F (227)
- Crystal Effects**
- Transparent Effects**
- Crystal AB F (001 AB)
- Crystal Golden Shadow F (001 GSHA)
- Crystal Silver Shade F (001 SSHA)

53 730 Crystal Stud (long shaft)

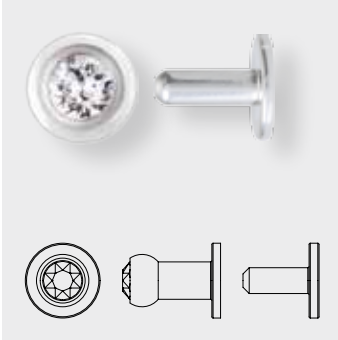

SS PP 24
M 48 PCS 100%

53 731 Crystal Stud (short shaft)



SS PP 24
M 48 PCS 100%

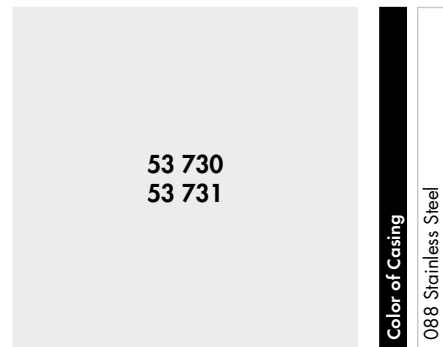

- Crystal**
- Crystal F (001)
- Colors**
- Plain Colors**
- Amethyst F (204)
- Black Diamond F (215)
- Dark Indigo F (288)
- Denim Blue F (266)
- Fuchsia F (502)
- Greige F (284)
- Jet F (280)
- Light Colorado Topaz F (246)
- Light Siam F (227)
- Light Turquoise F (263)
- Peridot F (214)
- Rose F (209)
- Sapphire F (206)
- Siam F (208)
- Smoked Topaz F (220)
- Topaz F (203)
- Vintage Rose F (319)
- Crystal Effects**
- Transparent Effects**
- Crystal AB F (001 AB)
- Crystal Blue Shade F (001 BLSH)
- Crystal Golden Shadow F (001 GSHA)
- Crystal Luminous Green F (001 LUMG)
- Crystal Silver Night F (001 SINI)
- Crystal Silver Shade F (001 SSHA)

Crystal Mesh

Crystal Mesh is a flexible metal mesh carrier with integrated loose crystals. The product is available in a wide range of colors and casings, either as a Hotfix version, which can be applied using heat, or as a No Hotfix version that can be hand- or machine-sewn. Customized solutions are possible and customers are able to choose special motifs incorporating up to nine colors. Crystal Mesh is suitable for use in a wide range of segments such as the textile and accessories segments.

ARTICLE EXPLANATION - SHEETS

40 000

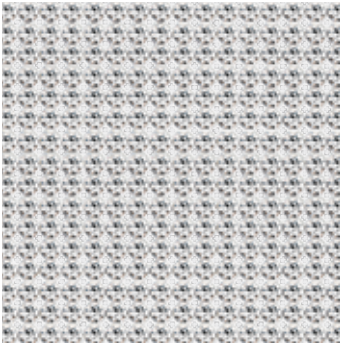

SH 100	
S ~500x200	
SS PP 21	
M 1 SH	100%

40 000	SH	S	SS	M	100%
Article number	Sheet	Sheet size in mm	Stone size	Minimum order quantity in sheets (SH)	Documentation size in %

ORDERING EXAMPLE & PRODUCT VARIETY EXPLANATION

40 000	100	082	001	NOHF
Article number	Sheet	Color of casing	Color of crystals	Hotfix Technology
	100 Standard sheet (~500x200 mm)	012 Black* 081 Gold** 082 Silver**	Please see the respective product matrix for all available code references.	HF With Hotfix glue NOHF Without Hotfix glue

* Alu: 012 Black
**Brass: 081 Gold, 082 Silver

ARTICLE EXPLANATION - ROWS

40 001

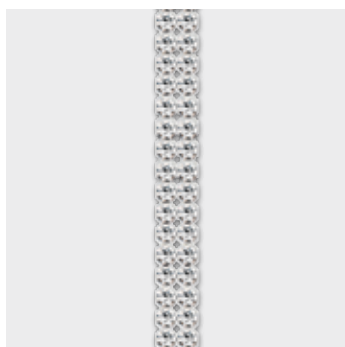

R	002-033
SS	PP 21
M	10 M
	100%

40 001	R	SS	M	100%
Article number	Number of rows	Stone size	Minimum order quantity in meters (M)	Documentation size in %
This article is available from 2 to 33 rows.				

ORDERING EXAMPLE & PRODUCT VARIETY EXPLANATION

40 001	002	082	001	HF
Article number	3-digit code for number of rows	Color of casing	Color of crystals	Hofix Technology
		012 Black*	Please see the respective product matrix for all available code references.	HF With Hofix glue
		081 Gold**		NOHF Without Hofix glue
		082 Silver**		

* Alu: 012 Black
 **Brass: 081 Gold, 082 Silver

Crystal Mesh

40 000

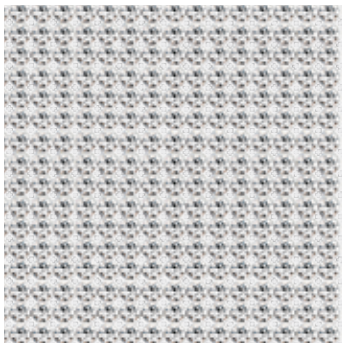

SH 100	
S ~500x200	
SS PP 21	
M 1 SH	100%

40 001

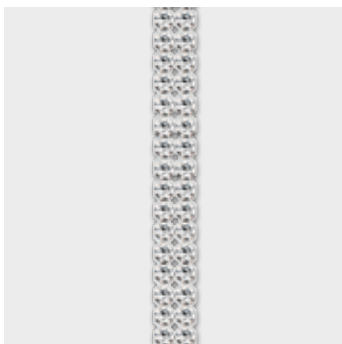

R 002-033	
SS PP 21	
M 10 M	100%

Crystal Mesh Standard

	Color of Casing		
	012 Black	081 Gold	082 Silver
40 000 40 001			
Crystal			
Crystal F (001)	■	■	■
Colors			
Plain Colors			
Amethyst F (204)	■	■	■
Aquamarine F (202)	■	■	■
Black Diamond F (215)	■	■	■
Blue Zircon F (229)	■	■	■
Dark Indigo F (288)	■	■	■
Dark Moss Green F (260)	■	■	■
Denim Blue F (266)	■	■	■
Emerald F (205)	■	■	■
Fern Green F (291)	■	■	■
Fuchsia F (502)	■	■	■
Greige F (284)	■	■	■
Indian Pink F (289)	■	■	■
Jet F (280)	■	■	■
Jonquil F (213)	■	■	■
Light Amethyst F (212)	■	■	■
Light Colorado Topaz F (246)	■	■	■
Light Rose F (223)	■	■	■
Light Sapphire F (211)	■	■	■
Light Siam F (227)	■	■	■
Light Silk F (261)	■	■	■
Light Turquoise F (263)	■	■	■
Padparadscha F (542)	■	■	■
Peridot F (214)	■	■	■
Provence Lavender F (283)	■	■	■
Purple Velvet F (277)	■	■	■
Rose F (209)	■	■	■
Rose Peach F (262)	■	■	■
Sapphire F (206)	■	■	■
Sunflower F (292)	■	■	■
Siam F (208)	■	■	■
Silk F (391)	■	■	■
Smoked Topaz F (220)	■	■	■
Tangerine F (259)	■	■	■
Tanzanite F (539)	■	■	■
Topaz F (203)	■	■	■
Vintage Rose F (319)	■	■	■
Light Multi F (908)*	■	■	■
Rainbow Multi F (909)**	■	■	■

* Light Multi F consists of Crystal, Peridot, Light Amethyst, Jonquil, Aquamarine.

** Rainbow Multi F consists of Topaz, Light Siam, Fuchsia, Peridot, Sapphire.

40 000
40 001

Color of Casing	012 Black	081 Gold	082 Silver
Opal Colors			
Palace Green Opal F (393)	■	■	■
Rose Water Opal F (395)	■	■	■
Ceramic Colors			
Marbled Black (653)	■	■	■
Marbled Blue (654)	■	■	■
Marbled Light Grey (657)	■	■	■
Marbled Terracotta (655)	■	■	■
Marbled Yellow (652)	■	■	■
Crystal Effects			
Transparent Effects			
Crystal AB F (001 AB)	■	■	■
Crystal Antique Pink F (001 ANTP)	■	■	■
Crystal Blue Shade F (001 BLSH)	■	■	■
Crystal Bronze Shade F (001 BRSH)	■	■	■
Crystal Golden Shadow F (001 GSHA)	■	■	■
Crystal Lilac Shadow F (001 LISH)	■	■	■
Crystal Luminous Green F (001 LUMG)	■	■	■
Crystal Moonlight F (001 MOL)	■	■	■
Crystal Silver Night F (001 SINI)	■	■	■
Crystal Silver Shade F (001 SSHA)	■	■	■

40 000
40 001

Color of Casing	012 Black	081 Gold	082 Silver
Metallic Effects			
Crystal Dorado F (001 DOR)	■	■	■
Crystal Iridescent Green F (001 IRIG)	■	■	■
Crystal Metallic Blue F (001 METBL)	■	■	■
Crystal Metallic Light Gold F (001 MLGLD)	■	■	■
Crystal Rose Gold F (001 ROGL)	■	■	■
Color Effects			
Metallic Effects			
Jet Hematite F (280 HEM)	■	■	■
Jet Nut F (280 NUT)	■	■	■

AVAILABLE CASING COLORS

Crystal Mesh Standard is available with black, gold and silver casing. Please see the product matrix for all available options.

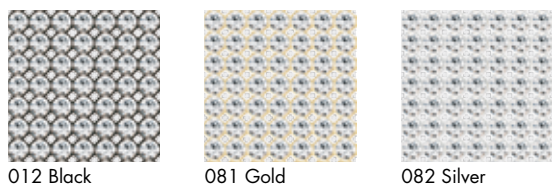

Crystal Mesh

Crystal Mesh XL

40 100



SH	100
S	~500x200
SS	SS 24
M	1 SH 100%

40 101



R	002-018
SS	SS 24
M	10 M 100%

40 100
40 101

Color of Casing	012 Black	081 Gold	082 Silver
Crystal			
Crystal F (001)	■	■	■
Colors			
Plain Colors			
Black Diamond F (215)	■	■	■
Jet F (280)	■	■	■
Light Colorado Topaz F (246)	■	■	■
Light Peach F (362)	■	■	■
Light Sapphire F (211)	■	■	■
Light Siam F (227)	■	■	■
Rose F (209)	■	■	■
Ceramic Colors			
Marbled Black (653)	■	■	■
Marbled Blue (654)	■	■	■
Marbled Light Grey (657)	■	■	■
Marbled Terracotta (655)	■	■	■
Marbled Yellow (652)	■	■	■
Crystal Effects			
Transparent Effects			
Crystal AB F (001 AB)	■	■	■
Crystal Golden Shadow F (001 GSHA)	■	■	■
Crystal Silver Shade F (001 SSHA)	■	■	■
Color Effects			
Metallic Effects			
Jet Hematite F (280 HEM)	■	■	■

AVAILABLE COLORS & EFFECTS

Colors



Crystal F
(001)



Rose F
(209)

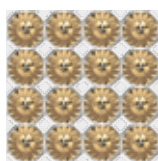

Light Colorado
Topaz F (246)

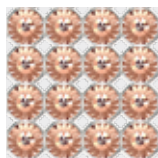

Light Peach F
(362)

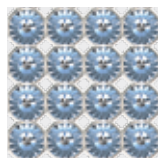

Light Sapphire F
(211)



Jet
(280)



Light Siam F
(227)

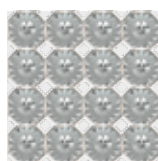

Black Diamond F
(215)

Effects

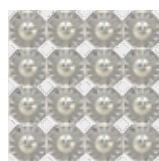

Crystal Silver Shade F
(001_SSHA)

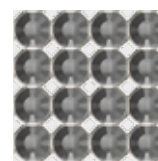

Jet Hematite
(280_HEM)



Crystal Aurore Boreale F
(001_AB)

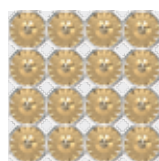

Crystal Golden Shadow F
(001_GSHA)

AVAILABLE CERAMICS COLORS

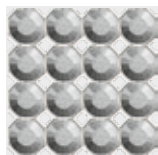

Marbled Light
Grey (657)

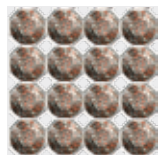

Marbled Terracotta
(655)

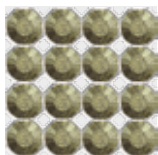

Marbled Yellow
(652)



Marbled Blue
(654)

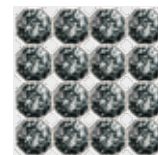

Marbled Black
(653)

AVAILABLE CASING COLORS

Crystal Mesh XL is available with black, gold and silver casing. Please see the product matrix for all available options.



012 Black

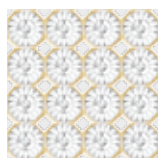

081 Gold



082 Silver

Crystal Mesh

40 200

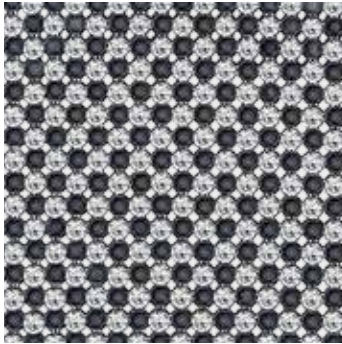

SH 100	
S ~500x200	
SS PP 21	
M 1 SH	100%

40 201

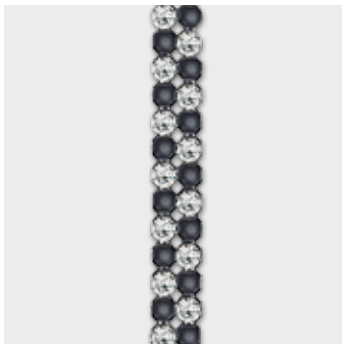

R 002-033	
SS PP 21	
M 10 M	100%

Crystal Mesh Metallisée



	Color of Casing		
	012 Black	081 Gold	082 Silver
Crystal			
Crystal F (001)	■	■	■
Colors			
Plain Colors			
Amethyst F (204)	■	■	■
Black Diamond F (215)	■	■	■
Dark Moss Green F (260)	■	■	■
Denim Blue F (266)	■	■	■
Greige F (284)	■	■	■
Jet F (280)	■	■	■
Light Colorado Topaz F (246)	■	■	■
Light Sapphire F (211)	■	■	■
Light Silk F (261)	■	■	■
Light Turquoise F (263)	■	■	■
Tangerine F (259)	■	■	■
Ceramic Colors			
Marbled Black (653)	■	■	■
Marbled Blue (654)	■	■	■
Marbled Light Grey (657)	■	■	■
Marbled Terracotta (655)	■	■	■
Marbled Yellow (652)	■	■	■
Crystal Effects			
Transparent Effects			
Crystal AB F (001 AB)	■	■	■
Crystal Blue Shade F (001 BLSH)	■	■	■
Crystal Bronze Shade F (001 BRSH)	■	■	■
Crystal Golden Shadow F (001 GSHA)	■	■	■
Crystal Lilac Shadow F (001 LISH)	■	■	■
Crystal Luminous Green F (001 LUMG)	■	■	■
Crystal Moonlight F (001 MOL)	■	■	■
Crystal Silver Night F (001 SINI)	■	■	■
Crystal Silver Shade F (001 SSHA)	■	■	■
Metallic Effects			
Crystal Dorado F (001 DOR)	■	■	■
Crystal Iridescent Green F (001 IRIG)	■	■	■
Crystal Metallic Blue F (001 METBL)	■	■	■
Crystal Metallic Light Gold F (001 MGLD)	■	■	■
Crystal Rose Gold F (001 ROGL)	■	■	■
Color Effects			
Metallic Effects			
Jet Hematite F (280 HEM)	■	■	■
Jet Nut F (280 NUT)	■	■	■

AVAILABLE CASING COLORS

Crystal Mesh Métallisée is available with black, gold and silver casing. Please see the respective product matrix for all available options.

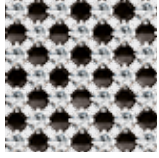

012 Black

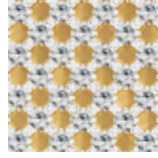

081 Gold



082 Silver

Crystal Mesh

40 400

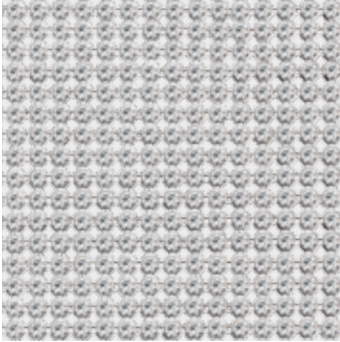

SH	100	
S	~500x200	
SS	PP 14	
M	1 SH	100%

40 401



R	002-033	
SS	PP 14	
M	10 M	100%

Crystal Aerial Mesh



40 400
40 401

Color of Casing

012 Black
081 Gold
082 Silver

Crystal	012 Black	081 Gold	082 Silver
Crystal			
Crystal F (001)	■	■	■
Colors			
Plain Colors			
Amethyst F (204)	■	■	■
Black Diamond F (215)	■	■	■
Dark Moss Green F (260)	■	■	■
Denim Blue F (266)	■	■	■
Greige F (284)	■	■	■
Jet F (280)	■	■	■
Light Colorado Topaz F (246)	■	■	■
Light Sapphire F (211)	■	■	■
Light Silk F (261)	■	■	■
Light Turquoise F (263)	■	■	■
Tangerine F (259)	■	■	■
Crystal Effects			
Transparent Effects			
Crystal AB F (001 AB)	■	■	■
Crystal Blue Shade F (001 BLSH)	■	■	■
Crystal Bronze Shade F (001 BRSH)	■	■	■
Crystal Golden Shadow F (001 GSHA)	■	■	■
Crystal Lilac Shadow F (001 LISH)	■	■	■
Crystal Luminous Green F (001 LUMG)	■	■	■
Crystal Moonlight F (001 MOL)	■	■	■
Crystal Silver Night F (001 SINI)	■	■	■
Crystal Silver Shade F (001 SSHA)	■	■	■
Metallic Effects			
Crystal Dorado F (001 DOR)	■	■	■
Crystal Iridescent Green F (001 IRIG)	■	■	■
Crystal Metallic Blue F (001 METBL)	■	■	■
Crystal Metallic Light Gold F (001 MLGLD)	■	■	■
Crystal Rose Gold F (001 ROGL)	■	■	■
Color Effects			
Metallic Effects			
Jet Hematite F (280 HEM)	■	■	■
Jet Nut F (280 NUT)	■	■	■

AVAILABLE CASING COLORS

Crystal Aerial Mesh is available with black, gold and silver casing. Please see the respective product matrix for all available options.

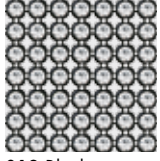

012 Black



081 Gold



082 Silver

AVAILABLE COLORS & EFFECTS

Please see all available casings and crystal colors & effects on the next pages.

Crystal Mesh

Crystal Aerial Mesh

Crystal F (001)



012 Black



081 Gold

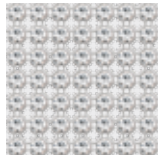

082 Silver

Greige F (284)

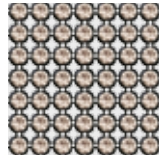

012 Black



081 Gold

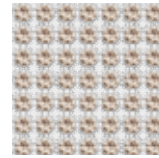

082 Silver

Light Silk F (261)

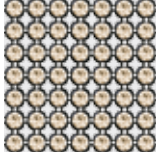

012 Black



081 Gold

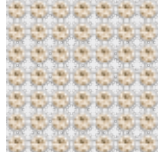

082 Silver

Light Colorado Topaz F (246)

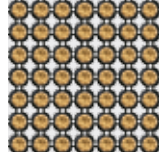

012 Black

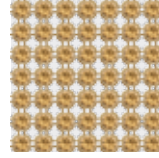

081 Gold



082 Silver

Amethyst F (204)

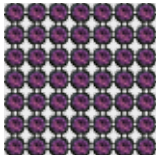

012 Black

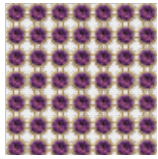

081 Gold

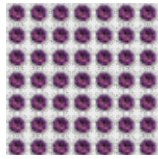

082 Silver

Tangerine F (259)

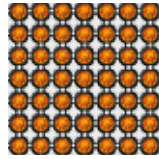

012 Black

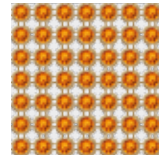

081 Gold

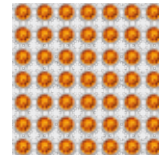

082 Silver

Light Sapphire F (211)

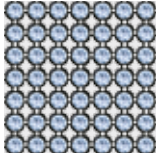

012 Black

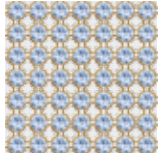

081 Gold

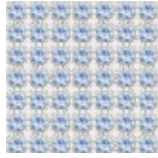

082 Silver

Jet F (280)

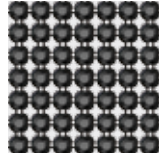

012 Black

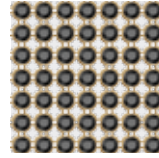

081 Gold

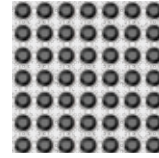

082 Silver

Light Turquoise F (263)

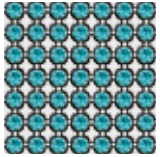

012 Black

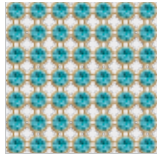

081 Gold

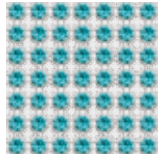

082 Silver

Denim Blue F (266)

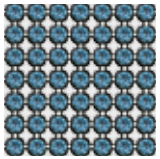

012 Black

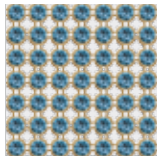

081 Gold

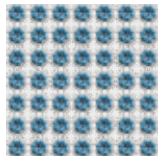

082 Silver

Black Diamond F (215)



012 Black

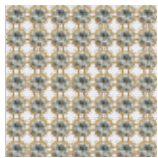

081 Gold

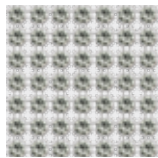

082 Silver

Dark Moss Green F (260)



012 Black

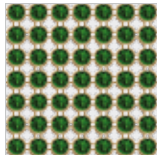

081 Gold

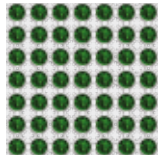

082 Silver

Classic Colors
Exclusive Colors

Crystal Mesh

Crystal Aerial Mesh

Crystal Silver Shade F (001 SSHA)



012 Black



081 Gold



082 Silver

Crystal Blue Shade F (001 BLSH)

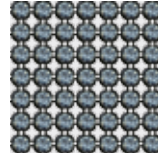

012 Black

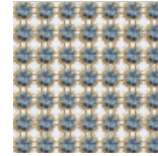

081 Gold

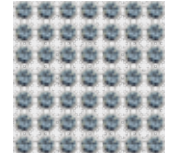

082 Silver

Crystal Moonlight F (001 MOL)



012 Black



081 Gold



082 Silver

Crystal Iridescent Green F (001 IRIG)

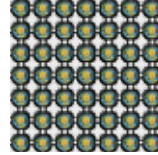

012 Black

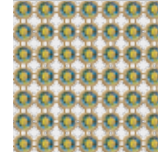

081 Gold

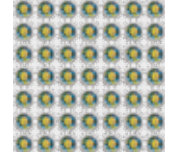

082 Silver

Crystal Aurore Boreale F (001 AB)

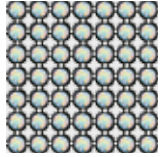

012 Black

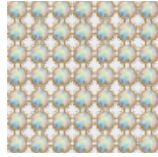

081 Gold



082 Silver

Crystal Dorado F (001 DOR)

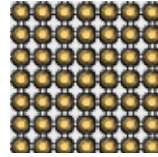

012 Black

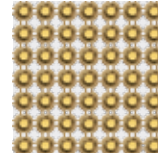

081 Gold

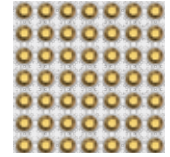

082 Silver

Crystal Luminous Green F (001 LUMG)



012 Black



081 Gold



082 Silver

Crystal Metallic Light Gold F (001 MLGLD)

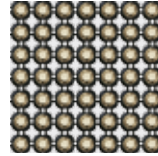

012 Black

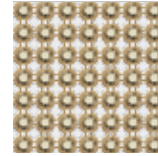

081 Gold

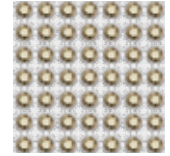

082 Silver

Crystal Golden Shadow F (001 GSHA)



012 Black

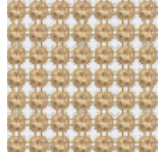

081 Gold

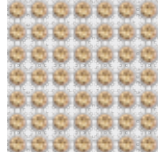

082 Silver

Crystal Bronze Shade F (001 BRSH)

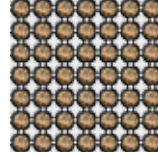

012 Black

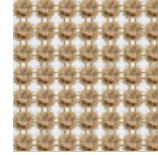

081 Gold

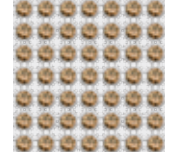

082 Silver

Crystal Rose Gold F (001 ROGL)

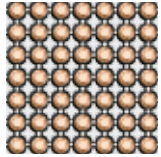

012 Black

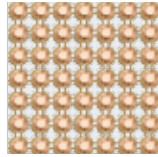

081 Gold

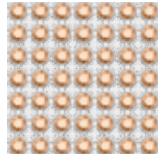

082 Silver

Crystal Silver Night F (001 SINI)

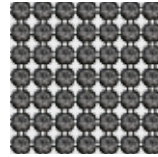

012 Black

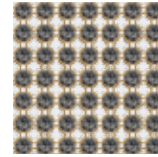

081 Gold

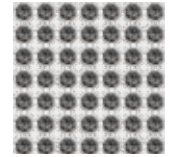

082 Silver

Crystal Lilac Shadow F (001 LISH)

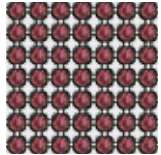

012 Black

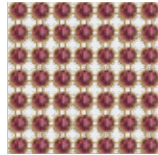

081 Gold

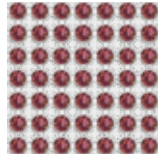

082 Silver

Jet Nut F (280 NUT)

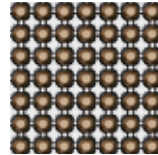

012 Black

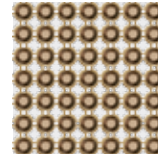

081 Gold

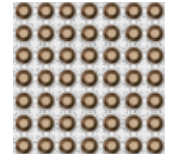

082 Silver

Crystal Metallic Blue F (001 METBL)

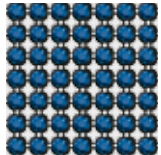

012 Black

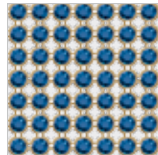

081 Gold

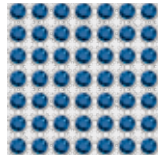

082 Silver

Jet Hematite F (280 HEM)

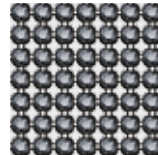

012 Black

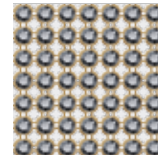

081 Gold

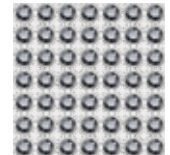

082 Silver

Classic Colors
Exclusive Colors

ARTICLE EXPLANATION

40 701 Crystal Mesh Banding



R 006	
SS PP 21	
M 22 PCS	100%

40 701	R	SS	M
Article number	Number of rows	Stone size	Minimum order quantity in pieces (PCS)
This article is available with between four and six rows.			

ORDERING EXAMPLE & PRODUCT VARIETY EXPLANATION

40 701	004	S	B022	082	001
Article number	3-digit code for number of rows	Size	Color of banding	Color of casing	Color of crystals
	004 rows	S (151 mm)		012 Black	Please see the respective product matrix for all available code references.
	005 rows	M (162 mm)		081 Gold	
	006 rows	L (174 mm)		082 Silver	

AVAILABLE ROWS



4 rows (004)



5 rows (005)

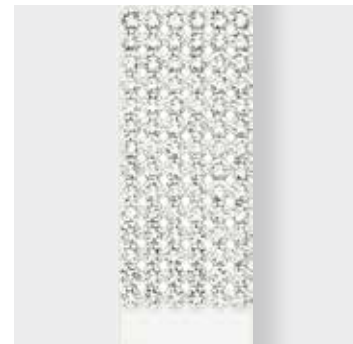

6 rows (006)

40 701		Color of Casing			Available Rows		
		012 Black	081 Gold	082 Silver	4 rows (004)	5 rows (005)	6 rows (006)
Crystal		Fabric Color					
Crystal F (001)					B022		
Colors							
Plain Colors							
Amethyst F (204)					B019		
Amethyst F (204)					B023		
Aquamarine F (202)					B009		
Black Diamond F (215)					B002		
Blue Zircon F (229)					B011		
Dark Indigo F (288)					B013		
Denim Blue F (266)					B010		
Emerald F (205)					B014		
Fuchsia F (502)					B025		
Jet F (280)					B012		
Light Colorado Topaz F (246)					B006		
Light Colorado Topaz F (246)					B016		
Light Rose F (223)					B021		
Purple Velvet F (277)					B026		
Rose F (209)					B018		
Siam F (208)					B017		
Smoked Topaz F (220)					B008		
Opal Colors							
Palace Green Opal F (393)					B015		
Crystal Effects							
Transparent Effects							
Crystal AB F (001 AB)					B004		
Crystal AB F (001 AB)					B020		
Crystal Golden Shadow F (001 GSHA)					B005		
Crystal Silver Night F (001 SINI)					B001		
Crystal Silver Shade F (001 SSHA)					B003		
Metallic Effects							
Crystal Metallic Blue F (001 METBL)					B024		
Color Effects							
Metallic Effects							
Jet Hematite F (280 HEM)					B012		
Jet Nut F (280 NUT)					B008		

ARTICLE EXPLANATION

40 769 **04**



C	012-206/266/280/001METBL/288
E	PP21/PP21/PP21/PP21/PP21
S	~239x82
M	4 PCS 17%

40 769	04	C	E	S	M	17%
Article number	This product is shown on flag number 04	Color assortment	Elements For details, please refer to the sizes overview at the end of the Collection.	Motif size in mm	Minimum order quantity in pieces (PCS)	Documentation size in %

ORDERING EXAMPLE & PRODUCT VARIETY EXPLANATION

40 769	012	206	266	280	001METBL	288
Article number	Color of casing	Crystal color corresponding to element 1; color of most frequently used element in the motif	Crystal color corresponding to element 2; color of second most frequently used element in the motif	Crystal color corresponding to element 3; color of third most frequently used element in the motif	Crystal color corresponding to element 4; color of fourth most frequently used element in the motif	Crystal color corresponding to element 5; color of fifth most frequently used element in the motif

Please see the respective product matrix for all available code references.

* Alu: 012 Black
 **Brass: 081 Gold, 082 Silver

Crystal Mesh

Motifs

Standard Collection



Standard Collection

40 756

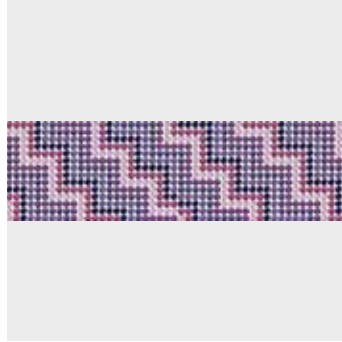

C	012-277/204/502/212/539/288
E	PP21/PP21/PP21/PP21/PP21/PP21
S	~200x41
M	8 PCS
	20%

40 761

04



C	012-280/280HEM/001IRIG/001DOR/ 393/001MLGLD/291/213/391
E	PP21/PP21/PP21/PP21/PP21/PP21/
S	~253x68
M	2 PCS
	10%

40 764

04



C	012-280/284/001MLGLD/001GSHA/ 246/280HEM
E	PP21/PP21/PP21/PP21/PP21/PP21
S	~168x192
M	2 PCS
	13%

40 765

04



C	012-280HEM/246/284/001GSHA/ 001MLGLD/280
E	PP21/PP21/PP21/PP21/PP21/PP21
S	~168x192
M	2 PCS
	13%

40 768



C	012-206/284/001METBL/001MLGLD/288
E	PP21/PP21/PP21/PP21/PP21
S	~239x62
M	6 PCS
	17%

40 769

04



C	012-206/266/280/001METBL/288
E	PP21/PP21/PP21/PP21/PP21
S	~239x82
M	4 PCS
	17%

40 770



C	012-001METBL/280HEM/539/277/280
E	PP21/PP21/PP21/PP21/PP21
S	~253x118
M	1 PCS
	16%

40 774

06



C	082-001SSHA/001METBL/288/654
E	PP21/PP21/PP21/PP21
S	~109x62
M	12 PCS
	35%

40 775

06



C	012-653/001SSHA/280
E	PP21/PP21/PP21
S	~130x65
M	9 PCS
	30%

40 776

06



C	082-657/MBBK/001SSHA/280HEM
E	PP21/PP21/PP21/PP21
S	~177x35
M	10 PCS
	23%

40 777

06

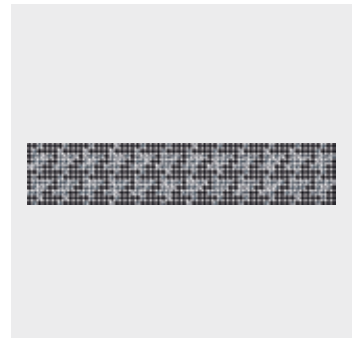

C	012-280/653
E	PP21/PP21
S	~177x35
M	10 PCS
	23%

Crystal Mesh

Motifs

Standard Collection

40 778 06



C 081-652/246/213/001DOR
E PP21/PP21/PP21/PP21
S ~177x97
M 4 PCS 23%

40 779 06

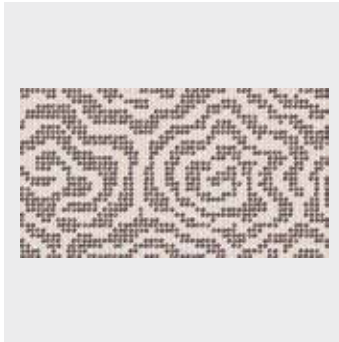

C 082-655/391
E PP21/PP21
S ~177x97
M 4 PCS 23%

40 786 05



C 012-001MOL/266/001METBL/288
E PP21/PP21/PP21/PP21
S ~212x174
M 2 PCS 20%

40 787 05

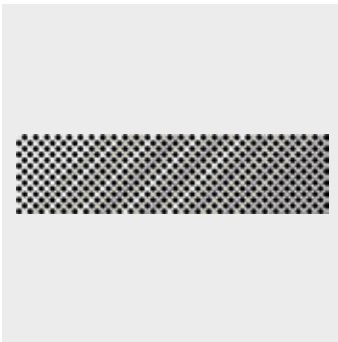

C 012-001SSHA/001MOL/001SINI
E PP21/PP21/PP21
S ~165x41
M 12 PCS 25%

40 788 05

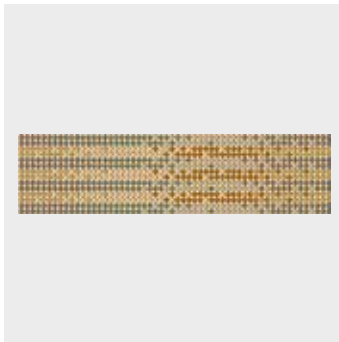

C 081-001METBL/266/211/001MLGLD/
284/001BRSH
E PP14/PP14/PP14/PP14/PP14/PP14
S ~165x41
M 12 PCS 25%

40 789 05



C 082-284/277/539/283
E PP21/PP21/PP21/PP21
S ~165x71
M 6 PCS 25%

40 790 05



C 082-001MOL/204/001GSHA/001SINI/
212/001MLGLD
E PP21/PP21/PP21/PP21/PP21/PP21
S ~168x71
M 4 PCS 25%

40 791 05



C 012-280HEM/001SINI/284/001SSHA/
001MOL/280/215
E PP21/PP21/PP21/PP21/PP21/PP21
S ~289x74
M 2 PCS 15%

40 909 02

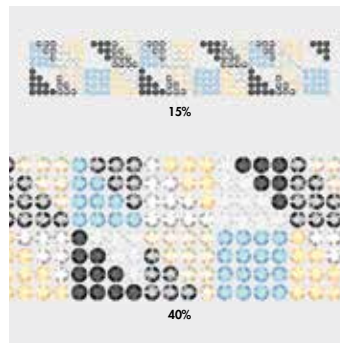

C 082-211/280HEM/001/280/001SSHA/
001AB/001GSHA
E SS24/SS24/SS24/SS24/SS24/SS24
S ~263x47
M 4 PCS

40 910 02



C 012280HEM7001AB/362/001SSHA/209/246
E SS24/SS24/SS24/SS24/SS24/SS24
S ~107x119
M 4 PCS 30%

40 919* 07

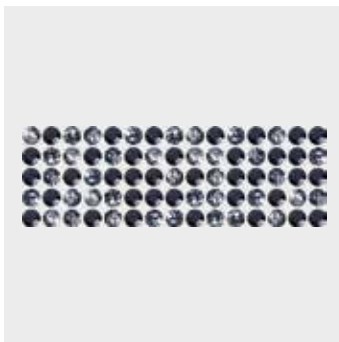

C 012-653/280HEM
E SS24/SS24
S ~89x29
M 35 PCS 45%

40 920 07

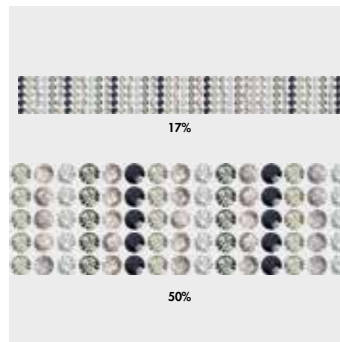

C 082-657/280HEM/001SSHA/215/001
E SS24/SS24/SS24/SS24/SS24
S ~251x29
M 7 PCS

* Motif can be ordered in different color combinations. Please refer to the Standard Flag no. 08 for inspiration.

Crystal Mesh

40 921

07

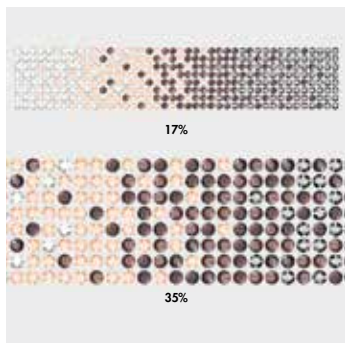

C	081-655/280HEM/001SSHA/362
E	SS24/SS24/SS24/SS24
S	~251x47
M	4 PCS

40 924

07

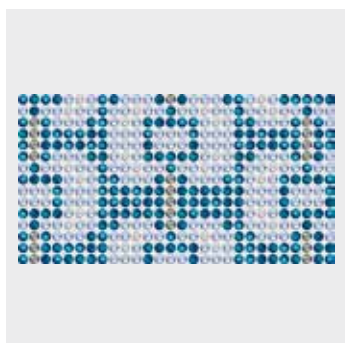

C	082-654/211/001/215
E	SS24/SS24/SS24/SS24
S	~167x89
M	4 PCS
	25%

Motifs

40 922

07

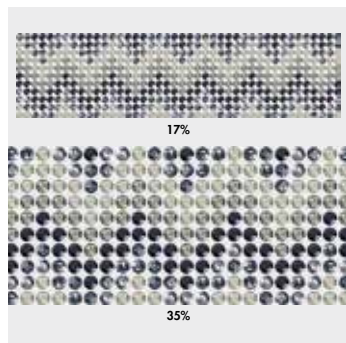

C	012-653/001SSHA/280HEM/215
E	SS24/SS24/SS24/SS24
S	~251x65
M	3 PCS

Standard Collection

40 923

07



C	081-652/220/001GSHA/215
E	SS24/SS24/SS24/SS24
S	~167x89
M	4 PCS
	25%

Crystal Mesh

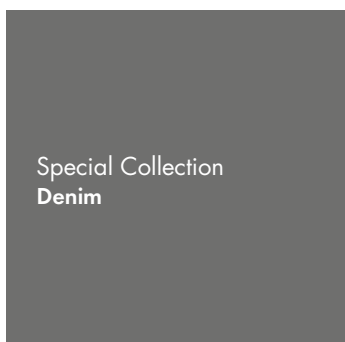

Motifs

40 792

03

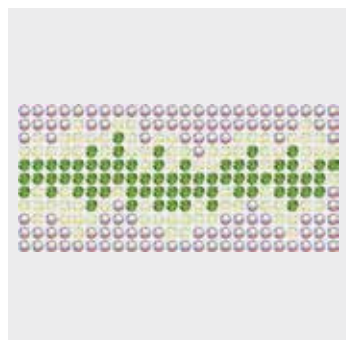

C	082-001AB/001LUMG/214
E	PP21/PP21/PP21
S	~71x32
M	42 PCS
	60%

Special Collection

Crystal Mesh

PRODUCT DETAILS

Article Size	Packing Unit = Minimum Order Quantity	Average Net Weight in Gram per Packing Unit Alu*	Average Net Weight in Gram per Packing Unit Brass**
40 000 100	1 sheet	270 g	440 g
40 001 002-033	10 meters	8.3 g per row/meter	13 g per row/meter
40 100 100	1 sheet	448 g	672 g
40 101 002-018	10 meters	24.8 g per row/meter	37.2 g per row/meter
40 200 100	1 sheet	180 g	332 g
40 201 002-033	10 meters	5.5 g per row/meter	10 g per row/meter
40 400 100	1 sheet	170 g	327 g
40 401 022-033	10 meters	5.2 g per row/meter	9.9 g per row/meter

* Alu: 012 Black

**Brass: 081 Gold, 082 Silver

A special motif is any individual design created by the customer, which is different from the Crystal Mesh Standard or Crystal Inspirations Collection. This service opens up many customization possibilities and enables you to profit from Swarovski's longtime experience and design expertise. A range of customization options for existing motifs is available (see "Customization Possibilities" below). You may also submit sketches of a design that will suit your special needs – such as a brand image or an image to suit a particular sales campaign. This will then be made up according to your specifications using Computer Aided Design, which allows for easy adjustments according to your needs.

CUSTOMIZATION POSSIBILITIES

- Change of size of an existing motif
- Logos or brand names
- Creation of single motifs or rows
- Up to nine colors are possible per Crystal Mesh Motif.

ORDERING PROCESS

Send the request with a drawing you wish to order to your nearest Swarovski sales office. Make sure you include all measurements to the desired motif. Please also indicate which product group your special motif refers to (Crystal Mesh Standard, Crystal Aerial Mesh etc.). You will then receive a quotation including your article number, minimum order quantity, price, and the line drawing of your special motif in PDF format. Please contact your Swarovski sales office again, if any changes need to be made. Your special motif will be produced and delivered following your confirmation.

PLEASE NOTE

Please always submit your drawing of the desired motif to represent it in the actual size you require. A small sketch, when enlarged to the desired size, will have blurred lines that will make it difficult to correctly reinterpret. Pictures or drawings representing 100% size of the design or very good quality scans in JPG, BMP or DXF format will ensure that we have clear data to work with. These can also be sent via email or on a CD-ROM. If sending a sewing pattern, please include the whole pattern and not just cut outs. When the sketch is submitted as a hard copy by fax or e-mail, please include a scale legend (e.g. copy/scan with ruler next to the drawing). This will ensure that the desired size of the motif can be identified.

Special productions are generally offered to all our customers if feasibility is given and our General Terms and Conditions are applied. Please note that the simple order of a design does not grant exclusive production of this design to the customer.

Cupchains & Findings

These products are metal chains and findings that can integrate either Round or Fancy Stones and Beads into any creative design. They can be divided into seven sub-categories: Single Stone Settings, Cupchains and Brass Components, Multi Stone Settings, Channels, Metal Buttons, Rondelles, and Linked Findings. Each of these groupings is available in a wide variety of shapes, sizes, colors, and platings.

SINGLE STONE SETTINGS

CUPCHAINS & BRASS COMPONENTS

MULTI STONE SETTINGS

CHANNELS

METAL BUTTONS

RONDELLES

LINKED FINDINGS

COLORS & EFFECTS

Colors



Crystal
001



White Opal
234



Light Silk
261



Silk
391



Light Peach
362

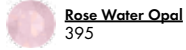

Rose Water Opal
395



Vintage Rose
319



Light Rose
223



Rose Peach
262

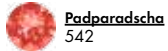

Padparadscha
542



Indian Pink
289



Hyacinth
236



Light Siam
227



Rose
209



Fuchsia
502



Ruby
501



Siam
208



Burgundy
515



Garnet
241



Amethyst
204

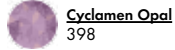

Cyclamen Opal
398



Purple Velvet
277



Tanzanite
539



Violet
371



Light Amethyst
212

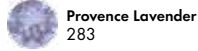

Provence Lavender
283



Light Sapphire
211



Light Azure
361



Aquamarine
202



Air Blue Opal
285



Sapphire
206



Capri Blue
243



Dark Indigo
288



Montana
207



Turquoise
267

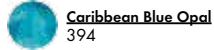

Caribbean Blue Opal
394



Light Turquoise
263



Blue Zircon
229



Indicolite
379

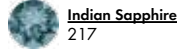

Indian Sapphire
217



Denim Blue
266

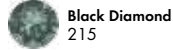

Black Diamond
215



Pacific Opal
390

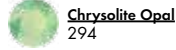

Chrysolite Opal
294



Chrysolite
238



Peridot
214



Erinite
360



Fern Green
291

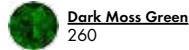

Dark Moss Green
260



Emerald
205



Palace Green Opal
393



Khaki
550

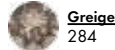

Greige
284

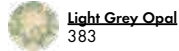

Light Grey Opal
383



Sand Opal
287



Light Colorado Topaz
246



Jonquil
213



Light Topaz
226



Sunflower
292



Topaz
203



Tangerine
259

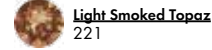

Light Smoked Topaz
221



Smoked Topaz
220



Smoky Quartz
225



Jet
280

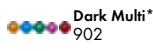

Dark Multi*
902



Light Multi**
907

Effects

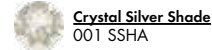

Crystal Silver Shade
001 SSHA

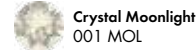

Crystal Moonlight
001 MOL

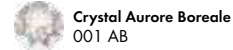

Crystal Aurora Boreale
001 AB



Crystal Golden Shadow
001 GSHA

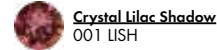

Crystal Lilac Shadow
001 LISH

Numerical Order

001	Crystal	215	Black Diamond	262	Rose Peach	362	Light Peach
001 AB	Crystal Aurore Boreale	217	Indian Sapphire	263	Light Turquoise	371	Violet
001 GSHA	Crystal Golden Shadow	220	Smoked Topaz	266	Denim Blue	379	Indicolite
001 LISH	Crystal Lilac Shadow	221	Light Smoked Topaz	267	Turquoise	383	Light Grey Opal
001 MOL	Crystal Moonlight	223	Light Rose	277	Purple Velvet	390	Pacific Opal
001 SSHA	Crystal Silver Shade	225	Smoky Quartz	280	Jet	391	Silk
202	Aquamarine	226	Light Topaz	283	Provence Lavender	393	Palace Green Opal
203	Topaz	227	Light Siam	284	Greige	394	Caribbean Blue Opal
204	Amethyst	229	Blue Zircon	285	Air Blue Opal	395	Rose Water Opal
205	Emerald	234	White Opal	287	Sand Opal	398	Cyclamen Opal
206	Sapphire	236	Hyacinth	288	Dark Indigo	501	Ruby
207	Montana	238	Chrysolite	289	Indian Pink	502	Fuchsia
208	Siam	241	Garnet	291	Fern Green	515	Burgundy
209	Rose	243	Capri Blue	292	Sunflower	539	Tanzanite
211	Light Sapphire	246	Light Colorado Topaz	294	Chrysolite Opal	542	Padparadscha
212	Light Amethyst	259	Tangerine	319	Vintage Rose	550	Khaki
213	Jonquil	260	Dark Moss Green	360	Erinite	902	Dark Multi*
214	Peridot	261	Light Silk	361	Light Azore	907	Light Multi**

Alphabetical Order

Air Blue Opal (285)	Dark Moss Green (260)	Light Colorado Topaz (246)	Rose (209)
Amethyst (204)	Dark Multi* (902)	Light Grey Opal (383)	Rose Peach (262)
Aquamarine (202)	Denim Blue (266)	Light Multi** (907)	Rose Water Opal (395)
Black Diamond (215)	Emerald (205)	Light Peach (362)	Ruby (501)
Blue Zircon (229)	Erinite (360)	Light Rose (223)	Sand Opal (287)
Burgundy (515)	Fern Green (291)	Light Sapphire (211)	Sapphire (206)
Capri Blue (243)	Fuchsia (502)	Light Siam (227)	Siam (208)
Caribbean Blue Opal (394)	Garnet (241)	Light Silk (261)	Silk (391)
Chrysolite (238)	Greige (284)	Light Smoked Topaz (221)	Smoked Topaz (220)
Chrysolite Opal (294)	Hyacinth (236)	Light Topaz (226)	Smoky Quartz (225)
Crystal (001)	Indian Pink (289)	Light Turquoise (263)	Sunflower (292)
Crystal Aurore Boreale (001 AB)	Indian Sapphire (217)	Montana (207)	Tangerine (259)
Crystal Golden Shadow (001 GSHA)	Indicolite (379)	Pacific Opal (390)	Tanzanite (539)
Crystal Lilac Shadow (001 LISH)	Jet (280)	Padparadscha (542)	Topaz (203)
Crystal Moonlight (001 MOL)	Jonquil (213)	Palace Green Opal (393)	Turquoise (267)
Crystal Silver Shade (001 SSHA)	Khaki (550)	Peridot (214)	Vintage Rose (319)
Cyclamen Opal (398)	Light Amethyst (212)	Provence Lavender (283)	Violet (371)
Dark Indigo (288)	Light Azore (361)	Purple Velvet (277)	White Opal (234)

This color chart is valid for the product group Cupchains & Findings.

The displayed assortment is not entirely available for all products within the product group. For details on available colors and effects, please see the product matrix for the respective item.

Classic Colors: This color range offers a wide choice of traditional Swarovski crystal colors.

Exclusive Colors: This color range is offered exclusively by Swarovski.

The standard assortment of colors and effects may vary according to the product group.

Slight changes in shades are unavoidable. Colors may vary according to cut and shape.

The plating resistance of effects is tested according to Swarovski's plating guidelines (WWW.SWAROVSKI.COM/PROFESSIONAL). Customers are advised to carry out their own tests if customers' plating parameters diverge from Swarovski plating guidelines.

* Dark Multi consists of Topaz, Sapphire, Emerald, Amethyst and Siam.

** Light Multi consists of Jonquil, Light Amethyst, Light Sapphire, Light Rose and Peridot.

Cupchains & Findings

PLATING DETAILS

Article Group	Available Plating Options
01 Single Stone Settings	(G) Gun Metal
02 & 09 Cupchains & Brass Components	(H) Rhodium
03 & 04 Multi Stone Settings*	(3) Gold
05 Channels	(R) Rose Gold
06 Metal Buttons	
07 Rondelles	
08 Linked Findings	

* Stretch articles 37 E00, 37 E04, 38 E02 and 31 E02 are only available with plating.

Cupchains & Findings

BASE ITEMS

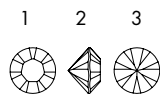

1028
PP 11, 13

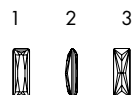

4547
15x5, 21x7 mm



1088
PP 14, 16, 18, 20, 24,
25, 28, 32
SS 19, 24, 29, 39



4565
14x10, 18x13 mm



1122
SS 29, 47



4627
27x18.5, 37x25.5 mm



1128
SS 29, 39



4744
10 mm



4127
30x22 mm



4884
6.6x6, 8.8x8 mm



4128
6x4, 8x6, 10x8 mm

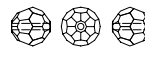

5000
6 mm



4161
15x5 mm

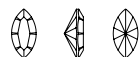

4228
10x5, 15x7 mm



4320
14x10, 18x13 mm



4327
30x20 mm



4328
8x4.8, 10x6 mm

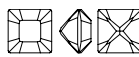

4428
2, 4, 6 mm



4470
12 mm



4501
4x2, 5x2.5, 7x3 mm

SINGLE STONE SETTINGS

These products are Round or Fancy Stones set in a metal cup, available in a variety of ring combinations as well as back configurations. Single Stone Settings come in a wide range of shapes and sizes. DIY Findings are also part of this product group.

ARTICLE EXPLANATION - BASE ITEM NUMBER

17 704 Round

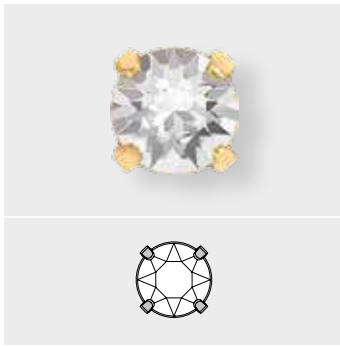

1	7	7	04
Product category	Stone code (type of stone used)	Setting code	Number of prongs in the setting (always 2-digit code)
1 Single Stone Settings	1 Baguette 2 Heart 3 Navette 4 Octagon 5 Oval 6 Pear 7 Round 8 Square 9 Other	2 Heart 3 Navette 5 Oval 6 Pear 7 Round 8 Square 9 Other 0 Basic	04 05 09 10

ORDERING EXAMPLE & PRODUCT VARIETY EXPLANATION

1	17 704	P18	00	C
Material type	Base item number	Stone size	Ring configuration	Back configuration
1 Brass		3-digit code from respective product matrix	H2 2 Holes 00 None 1C 1 Ring/Corner 1T 1 Ring/Top	A Headpin (0.05x3.81 cm) C Closed E Headpin (0.07x3.81 cm) L Large hole distance
F1	3	1088	F	001
Stone pattern	Plating	Base item art. no.	Foiling	Color of crystal
F1 Crystal/color/ effect	Can be added at an additional charge	1088 4127 4128 4161 4228 4320 4327 4328 4428 4470 4547 4565 4627 4744 4884	F Foiled	Please see the respective color chart at the beginning of this chapter for all available code references.
	Z No Plating G Gun Metal* 3 Gold* H Rhodium* R Rose Gold* * Anti nickel allergenic			

Not all configurations are available for all articles. Please refer to the respective product matrix for all available options.

11 004 Princess Baguette

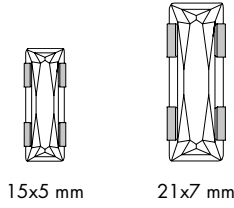

Stone Size		Ring Configuration		Back Configuration		Stone Art. No.
Code	Description	Code	Description	Code	Description	
15M	15x5 mm	1T	1R, Top	C	Closed	4547
15M	15x5 mm	H2	2 Holes	C	Closed	
21M	21x7 mm	1T	1R, Top	C	Closed	
21M	21x7 mm	H2	2 Holes	C	Closed	
21M	21x7 mm	H2	2 Holes	L	Large	

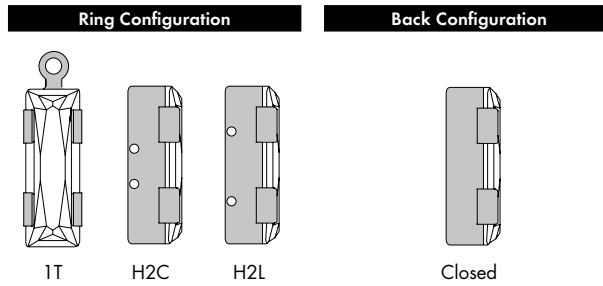

11 004

Size

15x5 mm

21x7 mm

- Crystal**
- Crystal F (001)
- Colors**
- Plain Colors**
- Aquamarine F (202)
- Black Diamond F (215)
- Jet F (280)
- Light Rose F (223)
- Tanzanite F (539)
- Crystal Effects**
- Transparent Effects**
- Crystal Golden Shadow F (001 GSHA)
- Crystal Silver Shade F (001 SSHA)

11 504 Classical Baguette

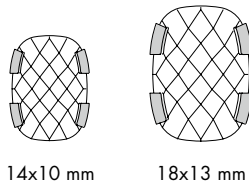
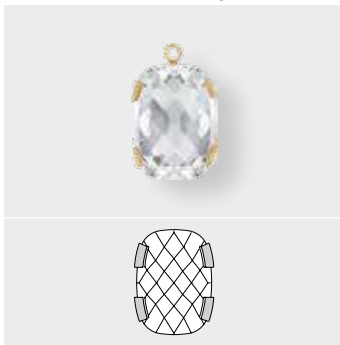

Stone Size		Ring Configuration		Back Configuration		Stone Art. No.
Code	Description	Code	Description	Code	Description	
14M	14x10 mm	1T	1R, Top	C	Closed	4565
14M	14x10 mm	H2	2 Holes	C	Closed	
18M	18x13 mm	1T	1R, Top	C	Closed	
18M	18x13 mm	H2	2 Holes	C	Closed	
18M	18x13 mm	H2	2 Holes	L	Large	

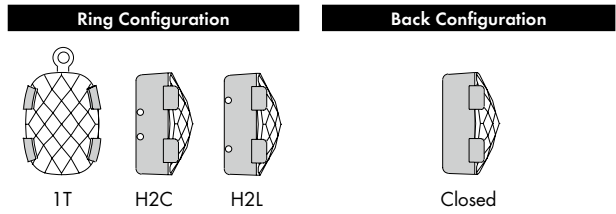

11 504	Size	14x10 mm	18x13 mm
	Crystal		
	Crystal F (001)		
	Colors		
	Plain Colors		
	Aquamarine F (202)		
	Jet F (280)		
	Light Rose F (223)		
	Tanzanite F (539)		
	Crystal Effects		
	Transparent Effects		
	Crystal Golden Shadow F (001 GSHA)		
	Crystal Silver Shade F (001 SSHA)		

12 204 Heart

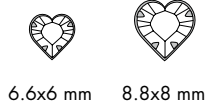
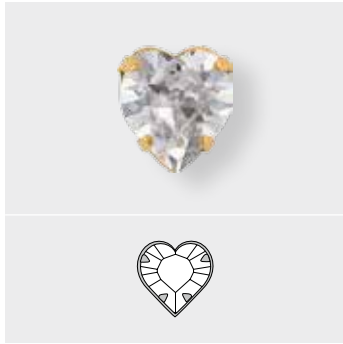

Stone Size		Ring Configuration		Back Configuration		Stone Art. No.
Code	Description	Code	Description	Code	Description	
06M	6.6x6 mm	1T	1 R, Top	C	Closed	4884
08M	8.8x8 mm	1T	1 R, Top	C	Closed	
08M	8.8x8 mm	H2	2 Holes	C	Closed	

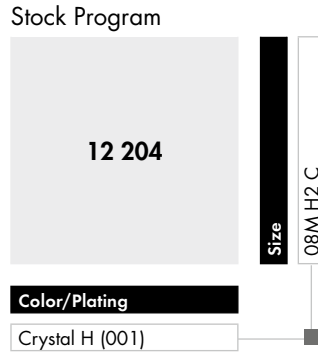
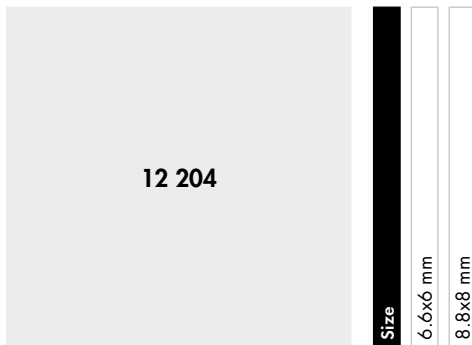
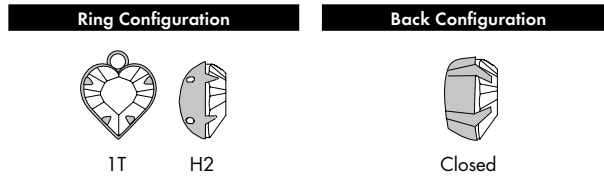

- Crystal**
- Crystal F (001)
- Colors**
- Plain Colors**
- Aquamarine F (202)
- Amethyst F (204)
- Black Diamond F (215)
- Emerald F (205)
- Fuchsia F (502)
- Light Amethyst F (212)
- Light Rose F (223)
- Montana F (207)
- Siam F (208)
- Tanzanite F (539)
- Opal Colors**
- Rose Water Opal F (395)
- White Opal F (234)
- Crystal Effects**
- Crystal AB F (001 AB)
- Crystal Golden Shadow F (001 GSHA)

13 304 Navette



Stone Size		Ring Configuration		Back Configuration		Stone Art. No.
Code	Description	Code	Description	Code	Description	
10M	10x5 mm	00	None	C	Closed	4228
10M	10x5 mm	1T	1R, Top	C	Closed	
10M	10x5 mm	H2	2 Holes	C	Closed	
X7M	15x7 mm	00	None	C	Closed	
X7M	15x7 mm	1T	1R, Top	C	Closed	
X7M	15x7 mm	H2	2 Holes	C	Closed	



Cupchains & Findings

13 304

Size
10x5 mm
15x7 mm

Crystal

Crystal F (001)

Colors

Plain Colors

Aquamarine F (202)

Amethyst F (204)

Black Diamond F (215)

Emerald F (205)

Fuchsia F (502)

Jet F (280)

Light Amethyst F (212)

Light Colorado Topaz F (246)

Light Rose F (223)

Montana F (207)

Siam F (208)

Tanzanite F (539)

Opal Colors

White Opal F (234)

Crystal Effects

Transparent Effects

Crystal AB F (001 AB)

Crystal Golden Shadow F (001 GSHA)

Crystal Lilac Shadow F (001 LISH)

Crystal Silver Shade F (001 SSHA)

Single Stone Settings

Stock Program

13 304

Size
10M H2 C
X7M H2 C

Color/Plating

Crystal H (001)

Crystal AB H (001 AB)

Jet H (280)

14 904

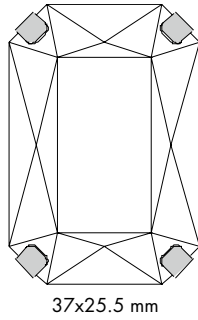
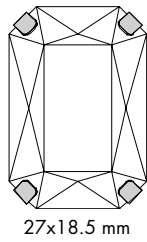
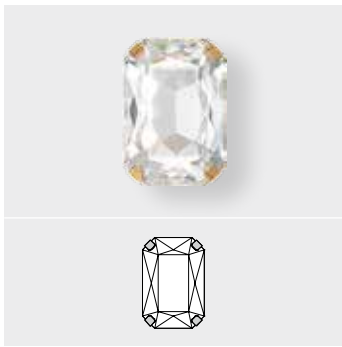

Stone Size		Ring Configuration		Back Configuration		Stone Art. No.
Code	Description	Code	Description	Code	Description	
27M	27x18.5 mm	1T	1R, Top	C	Closed	4627
27M	27x18.5 mm	H2	2 Holes	C	Closed	
27M	27x18.5 mm	H2	2 Holes	L	Large	
37M	37x25.5 mm	1T	1R, Top	C	Closed	
37M	37x25.5 mm	H2	2 Holes	C	Closed	
37M	37x25.5 mm	H2	2 Holes	L	Large	

Ring Configuration Back Configuration

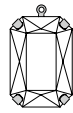

1T



H2C



H2L



Closed

14 904

Size: 27x18.5 mm, 37x25.5 mm

Crystal

- Crystal F (001)

Colors

Plain Colors

- Aquamarine F (202)
- Amethyst F (204)
- Black Diamond F (215)
- Emerald F (205)
- Fuchsia F (502)
- Jet F (280)
- Light Colorado Topaz F (246)
- Light Rose F (223)

14 904

Size: 27x18.5 mm, 37x25.5 mm

- Montana F (207)
- Tanzanite F (539)

Opal Colors

- White Opal F (234)

Crystal Effects

Transparent Effects

- Crystal AB F (001 AB)
- Crystal Golden Shadow F (001.GSHA)
- Crystal Silver Shade F (001.SSHA)

15 004 Oval

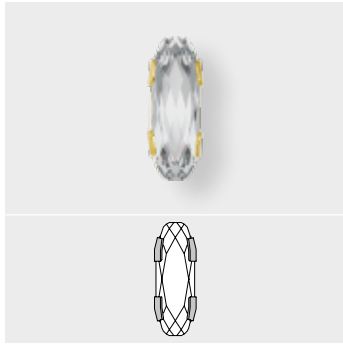

15x5 mm

Stone Size		Ring Configuration		Back Configuration		Stone Art. No.
Code	Description	Code	Description	Code	Description	
15M	15x5 mm	1T	1R, Top	C	Closed	4161
15M	15x5 mm	H2	2 Holes	C	Closed	

Ring Configuration Back Configuration

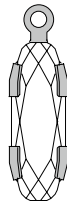

1T

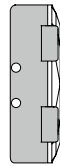

H2C



Closed

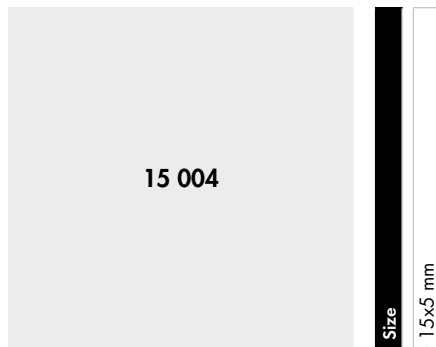

15 004

Size
15x5 mm

- Crystal**
- Crystal F (001)
- Colors**
- Plain Colors**
- Aquamarine F (202)
- Amethyst F (204)
- Black Diamond F (215)
- Light Colorado Topaz F (246)
- Light Rose F (223)

15 504 Oval

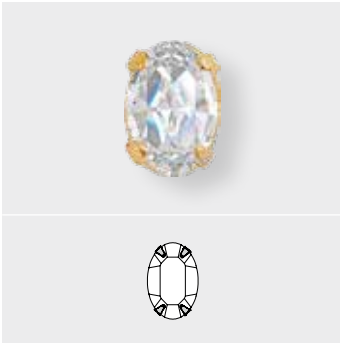

8x6 mm

10x8 mm

Stone Size		Ring Configuration		Back Configuration		Stone Art. No.
Code	Description	Code	Description	Code	Description	
08M	8x6 mm	1T	1R, Top	C	Closed	4128
08M	8x6 mm	H2	2 Holes	C	Closed	
10M	10x8 mm	1T	1R, Top	C	Closed	
10M	10x8 mm	H2	2 Holes	C	Closed	



15 504

Size

8x6 mm

10x8 mm

Crystal

- Crystal F (001)

Colors

Plain Colors

- Aquamarine F (202)
- Amethyst F (204)
- Black Diamond F (215)
- Emerald F (205)
- Fuchsia F (502)
- Jet F (280)
- Light Amethyst F (212)
- Light Rose F (223)
- Montana F (207)
- Siam F (208)

Crystal Effects

Transparent Effects

- Crystal AB F (001 AB)

15 504

Size

08M H2 C

10M H2 C

Color/Plating

- Crystal H (001)
- Crystal AB H (001 AB)

15 904

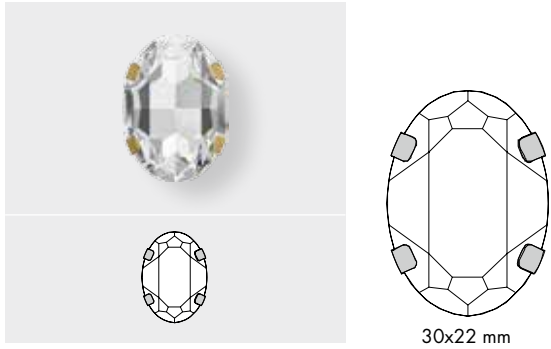

Stone Size		Ring Configuration		Back Configuration		Stone Art. No.
Code	Description	Code	Description	Code	Description	
30M	30x22 mm	1T	1R, Top	C	Closed	4127
30M	30x22 mm	H2	2 Holes	C	Closed	
30M	30x22 mm	H2	2 Holes	L	Large	

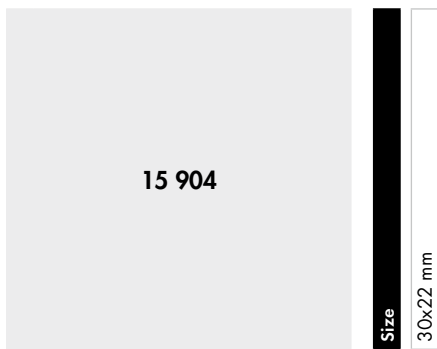
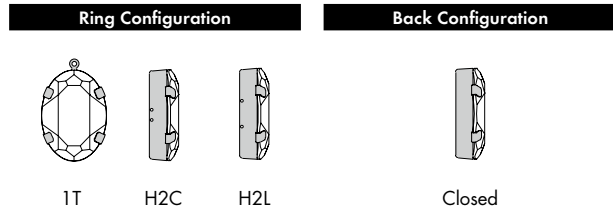

- Crystal**
- Crystal F (001)
- Colors**
- Plain Colors**
- Aquamarine F (202)
- Amethyst F (204)
- Black Diamond F (215)
- Fuchsia F (502)
- Jet F (280)
- Light Colorado Topaz F (246)
- Light Rose F (223)
- Montana F (207)
- Crystal Effects**
- Transparent Effects**
- Crystal AB F (001 AB)
- Crystal Golden Shadow F (001 GSHA)
- Crystal Lilac Shadow F (001 LISH)
- Crystal Silver Shade F (001 SSHA)

16 004 Pear

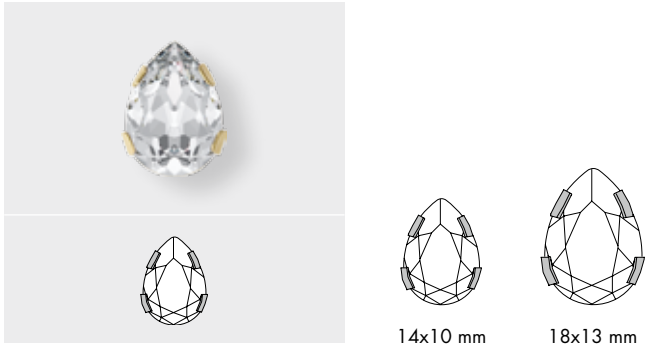

Stone Size		Ring Configuration		Back Configuration		Stone Art. No.
Code	Description	Code	Description	Code	Description	
14M	14x10 mm	1T	1R, Top	C	Closed	4320
14M	14x10 mm	H2	2 Holes	C	Closed	
18M	18x13 mm	1T	1R, Top	C	Closed	
18M	18x13 mm	H2	2 Holes	C	Closed	
18M	18x13 mm	H2	2 Holes	L	Large	

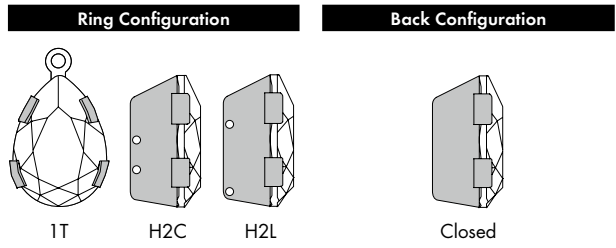

16 004

Size

14x10 mm

18x13 mm

Crystal

Crystal F (001)

Colors

Plain Colors

Aquamarine F (202)

Amethyst F (204)

Black Diamond F (215)

Emerald F (205)

Jet F (280)

Light Colorado Topaz F (246)

Montana F (207)

Siam F (208)

Tanzanite F (539)

16 004

Size

14x10 mm

18x13 mm

Opal Colors

Rose Water Opal F (395)

White Opal F (234)

Crystal Effects

Transparent Effects

Crystal AB F (001 AB)

Crystal Golden Shadow F (001 GSHA)

Crystal Lilac Shadow F (001 LISH)

Crystal Silver Shade F (001 SSHA)

16 604 Pear

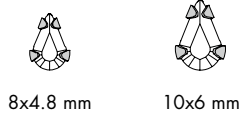
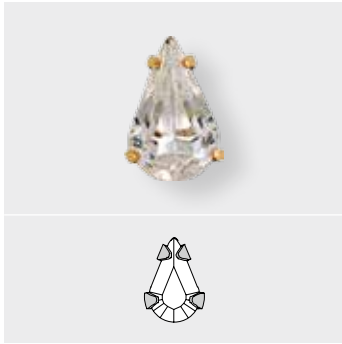

Stone Size		Ring Configuration		Back Configuration		Stone Art. No.
Code	Description	Code	Description	Code	Description	
08M	8x4.8 mm	1T	1R, Top	C	Closed	4328
08M	8x4.8 mm	H2	2 Holes	C	Closed	
10M	10x6 mm	1T	1R, Top	C	Closed	
10M	10x6 mm	H2	2 Holes	C	Closed	



16 604

Size

- 8x4.8 mm
- 10x6 mm

Crystal

- Crystal F (001)

Colors

Plain Colors

- Aquamarine F (202)
- Amethyst F (204)
- Black Diamond F (215)
- Jet F (280)
- Light Amethyst F (212)
- Light Colorado Topaz F (246)
- Light Rose F (223)
- Montana F (207)
- Siam F (208)
- Tanzanite F (539)

Crystal Effects

Transparent Effects

- Crystal Golden Shadow F (001 GSHA)

Stock Program

16 604

Color/Plating

- Crystal H (001)

Size

- 08M H2 C
- 10M H2 C

16 904



Stone Size		Ring Configuration		Back Configuration		Stone Art. No.
Code	Description	Code	Description	Code	Description	
30M	30x20 mm	1T	1R, Top	C	Closed	4327
30M	30x20 mm	H2	2 Holes	C	Closed	
30M	30x20 mm	H2	2 Holes	L	Large	

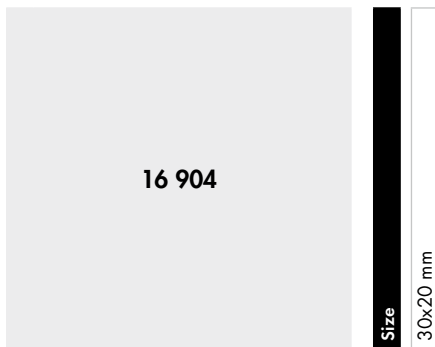
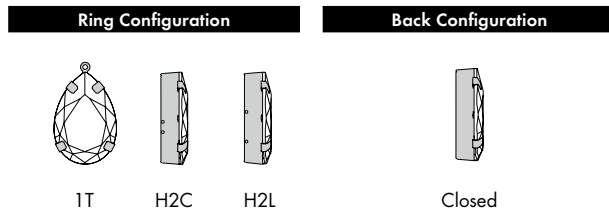

- Crystal**
- Crystal F (001)
- Colors**
- Plain Colors**
- Aquamarine F (202)
- Amethyst F (204)
- Black Diamond F (215)
- Fuchsia F (502)
- Jet F (280)
- Light Colorado Topaz F (246)
- Light Rose F (223)
- Montana F (207)
- Siam F (208)
- Tanzanite F (539)

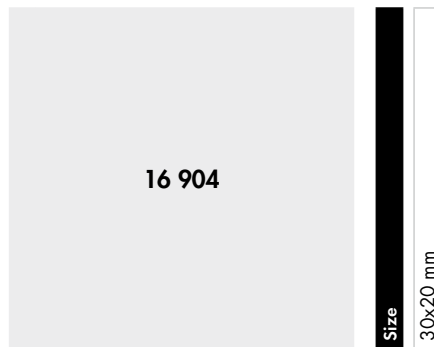

- Opal Colors**
- White Opal F (234)
- Crystal Effects**
- Transparent Effects**
- Crystal AB F (001 AB)
- Crystal Golden Shadow F (001 GSHA)
- Crystal Silver Shade F (001 SSHA)

17 009 Round

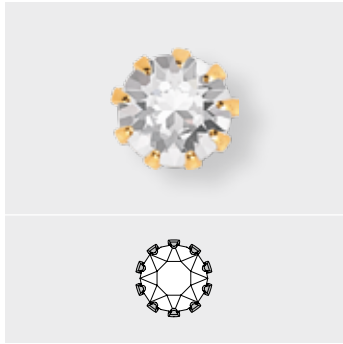

Stone Size		Ring Configuration		Back Configuration		Stone Art. No.
Code	Description	Code	Description	Code	Description	
P32	PP 32	00	None	C	Closed	1088
S19	SS 19	00	None	C	Closed	
S24	SS 24	00	None	C	Closed	

Back Configuration



Closed

17 009

Size

PP 32

SS 19

SS 24

Crystal	PP 32	SS 19	SS 24
Crystal F (001)	■	■	■
Colors			
Plain Colors			
Amethyst F (204)	■	■	■
Aquamarine F (202)	■	■	■
Black Diamond F (215)	■	■	■
Emerald F (205)	■	■	■
Fuchsia F (502)	■	■	■
Jet F (280)	■	■	■
Light Amethyst F (212)	■	■	■
Light Colorado Topaz F (246)	■	■	■
Light Rose F (223)	■	■	■
Montana F (207)	■	■	■
Siam F (208)	■	■	■
Tanzanite F (539)	■	■	■
Opal Colors			
Rose Water Opal F (395)	■	■	■
White Opal F (234)	■	■	■

17 009

Size

PP 32

SS 19

SS 24

Crystal Effects	PP 32	SS 19	SS 24
Transparent Effects			
Crystal AB F (001 AB)	■	■	■
Crystal Golden Shadow F (001 GSHA)	■	■	■
Crystal Lilac Shadow F (001 LISH)	■	■	■
Crystal Silver Shade F (001 SSHA)	■	■	■

Stock Program

17 009

Size

P32.00 C

S19.00 C

S24.00 C

Color/Plating

Crystal Z (001)

17 010 Round

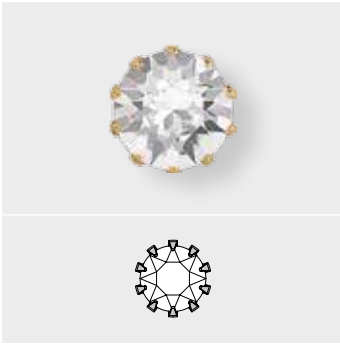

Stone Size		Ring Configuration		Back Configuration		Stone Art. No.
Code	Description	Code	Description	Code	Description	
S29	SS 29	00	None	C	Closed	1088

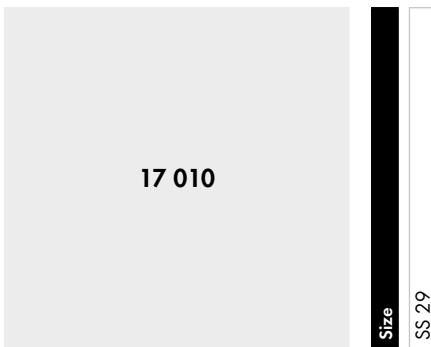
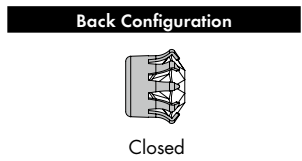

- Crystal**
- Crystal F (001)
- Colors**
- Plain Colors**
- Amethyst F (204)
- Aquamarine F (202)
- Black Diamond F (215)
- Emerald F (205)
- Fuchsia F (502)
- Jet F (280)
- Light Amethyst F (212)
- Light Colorado Topaz F (246)
- Light Rose F (223)
- Montana F (207)
- Siam F (208)
- Tanzanite F (539)
- Opal Colors**
- Rose Water Opal F (395)
- White Opal F (234)

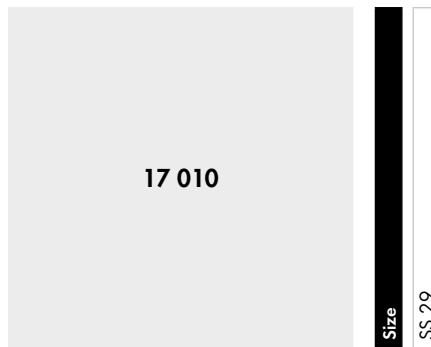

- Crystal Effects**
- Transparent Effects**
- Crystal AB F (001 AB)
- Crystal Golden Shadow F (001 GSHA)
- Crystal Lilac Shadow F (001 LISH)
- Crystal Silver Shade F (001 SSHA)

Stock Program

- Color/Plating**
- Crystal Z (001)

17 704 Round

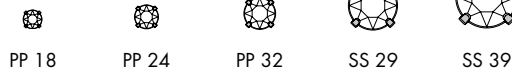
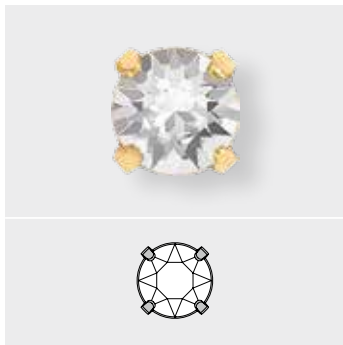

Stone Size		Ring Configuration		Back Configuration		Stone Art. No.
Code	Description	Code	Description	Code	Description	
P18	PP 18	00	None	A	Headpin (3.81x0.05 cm)	1088
P18	PP 18	00	None	E	Headpin (3.81x0.07 cm)	
P24	PP 24	1T	1R, Top	C	Closed	
P24	PP 24	00	None	A	Headpin (0.05x3.81 cm)	
P24	PP 24	00	None	E	Headpin (0.07x3.81 cm)	
P32	PP 32	1T	1R, Top	C	Closed	
P32	PP 32	00	None	A	Headpin (3.81x0.05 cm)	
P32	PP 32	00	None	E	Headpin (3.81x0.07 cm)	
S29	SS 29	1T	1R, Top	C	Closed	
S29	SS 29	H2	2 Holes	C	Closed	
S39	SS 39	1T	1R, Top	C	Closed	
S39	SS 39	H2	2 Holes	C	Closed	

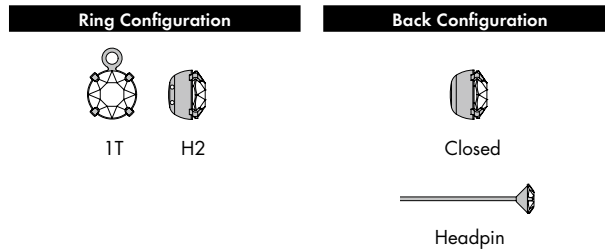

17 704		Size	PP 18	PP 24	PP 32	SS 29	SS 39
Crystal		Crystal F (001)	■	■	■	■	■
Colors							
Plain Colors		Amethyst F (204)	■	■	■	■	■
		Aquamarine F (202)	■	■	■	■	■
		Black Diamond F (215)	■	■	■	■	■
		Emerald F (205)	■	■	■	■	■
		Fuchsia F (502)	■	■	■	■	■
		Jet F (280)	■	■	■	■	■
		Light Amethyst F (212)	■	■	■	■	■
		Light Colorado Topaz F (246)	■	■	■	■	■
		Light Rose F (223)	■	■	■	■	■
		Montana F (207)	■	■	■	■	■
		Siam F (208)	■	■	■	■	■
		Tanzanite F (539)	■	■	■	■	■
Opal Colors		Rose Water Opal F (395)	■	■	■	■	■
		White Opal F (234)	■	■	■	■	■
Crystal Effects							
Transparent Effects		Crystal AB F (001 AB)	■	■	■	■	■
		Crystal Golden Shadow F (001 GSHA)	■	■	■	■	■
		Crystal Lilac Shadow F (001 LISH)	■	■	■	■	■
		Crystal Silver Shade F (001 SSHA)	■	■	■	■	■

17 704		Size	P18 00 A	P18 00 E	P24 00 A	P24 00 E	P24 1TC	P32 00 E	P32 1TC	S29 1TC	S29 H2 C
Color/Plating		Crystal 3 (001)	■	■	■	■	■	■	■	■	■
		Crystal H (001)	■	■	■	■	■	■	■	■	■
		Crystal Z (001)	■	■	■	■	■	■	■	■	■
		Crystal AB H (001 AB)	■	■	■	■	■	■	■	■	■

18 704 Antique Square

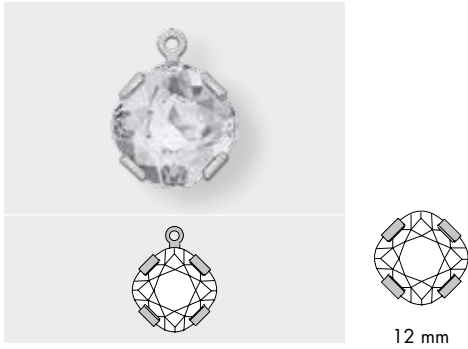

Stone Size		Ring Configuration		Back Configuration		Stone Art. No.
Code	Description	Code	Description	Code	Description	
12M	12 mm	1T	1R, Top	C	Closed	4470
12M	12 mm	H2	2 Holes	C	Closed	

Ring Configuration	Back Configuration
 1T	 H2
	 Closed

18 704

Size
12 mm

Crystal

Crystal F (001)

Colors

Plain Colors

Aquamarine F (202)

Black Diamond F (215)

Jet F (280)

Light Colorado Topaz F (246)

Siam F (208)

Tanzanite F (539)

Opal Colors

Rose Water Opal F (395)

White Opal F (234)

Crystal Effects

Transparent Effects

Crystal Golden Shadow F (001 GSHA)

Crystal Silver Shade F (001 SSHA)

18 704

Size
12M 1T C

Color/Plating

Crystal H (001)

18 804 Square

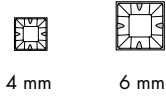

Stone Size		Ring Configuration		Back Configuration		Stone Art. No.
Code	Description	Code	Description	Code	Description	
04M	4 mm	1C	1R, Corner	C	Closed	4428
06M	6 mm	1C	1R, Corner	C	Closed	
06M	6 mm	H2	2 Holes	C	Closed	

Ring Configuration	Back Configuration
1C H2	Closed

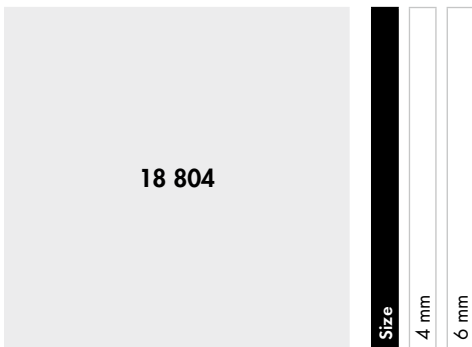

- Crystal**
- Crystal F (001)
- Colors**
- Plain Colors**
- Amethyst F (204)
- Aquamarine F (202)
- Black Diamond F (215)
- Emerald F (205)
- Fuchsia F (502)
- Jet F (280)
- Light Amethyst F (212)
- Light Colorado Topaz F (246)
- Light Rose F (223)
- Montana F (207)
- Siam F (208)
- Tanzanite F (539)
- Opal Colors**
- White Opal F (234)

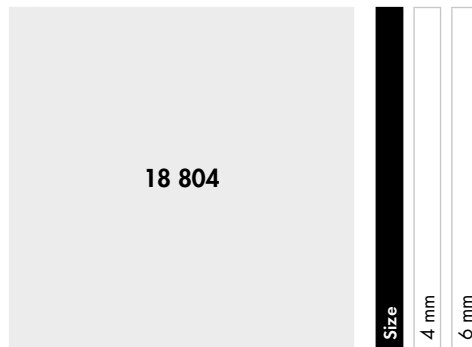

- Crystal Effects**
- Transparent Effects**
- Crystal AB F (001 AB)
- Crystal Golden Shadow F (001 GSHA)
- Crystal Lilac Shadow F (001 LISH)
- Crystal Silver Shade F (001 SSHA)

Stock Program

Size: 04M 1C C, 06M H2 C

Color/Plating

Crystal H (001)

19 905 Flower Finding

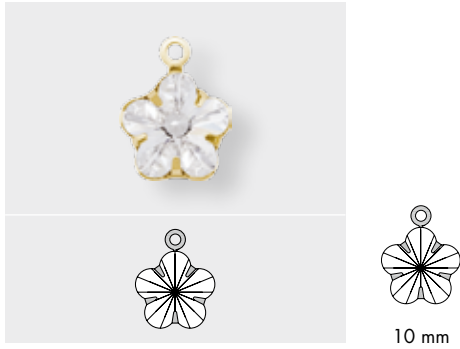

Stone Size		Ring Configuration		Back Configuration		Stone Art. No.
Code	Description	Code	Description	Code	Description	
10M	10 mm	1T	1R, Top	C	Closed	4744
10M	10 mm	H2	2 Holes	C	Closed	

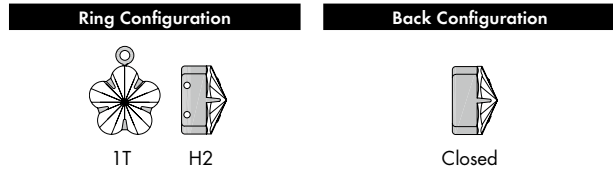

19 905

Size 10 mm

Crystal

- Crystal F (001)

Colors

Plain Colors

- Amethyst F (204)
- Fuchsia F (502)
- Light Rose F (223)

Crystal Effects

Transparent Effects

- Crystal AB F (001 AB)

Stock Program

19 905

Size 10M 1T C

Size 10M H2 C

Color/Plating

Crystal H (001)

CUPCHAINS & BRASS COMPONENTS

Cupchains are metal chains that integrate Round or Fancy Stones. Cupchains are offered in a large variety of shapes, sizes, colors, and platings.

Brass Components are end fasteners that match Cupchains from our assortment on offer. Also offered are Lobster Claws for Channel and Bead Chains, which are attractive components that are easy to apply.

ARTICLE EXPLANATION - BASE ITEM NUMBER

27 004 Round



2	7	0	04
Product category	Stone code (type of stone used)	Setting code	Number of prongs in the setting (always 2-digit code)
2 Cupchains	1 Baguette 3 Navette 7 Round 8 Square	0 Basic 1 Extended 2 Skip/String 3 Tiffany	02 04 D4 Snake R4 08 00 Bezel

ORDERING EXAMPLE & PRODUCT VARIETY EXPLANATION

1	27 004	P24	00	C
Material type	Base item number	Stone size	Ring configuration	Back configuration
1 Brass		3-digit code from respective product matrix	00 None	C Closed O Open
>> C1	Z	1028	F	202
Stone pattern	Plating	Base item art. no.	Foiling	Color of crystal
A1 Crystal with effect C1 Color K1 Crystal 02 2 alternate colors 03 3 alternate colors 04 4 alternate colors	Can be added at an additional charge Z No Plating G Gun Metal* 3 Gold* H Rhodium* R Rose Gold*	1028 1088 4228 4428 4501	F Foiled	Please see the respective color chart at the beginning of this chapter for all available code references.

* Anti nickel allergenic

Not all configurations are available for all articles. Please refer to the respective product matrix for available combinations.

ORDERING EXAMPLE & PRODUCT VARIETY EXPLANATION

00 011

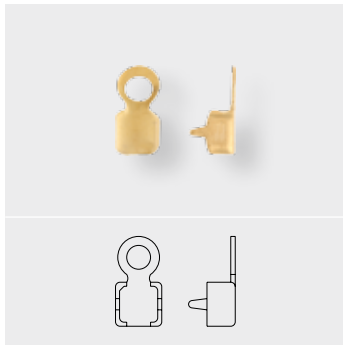

1	00 011	000	00	0	G
Material type	Base item number	No stone	No ring configuration	No back configuration	Plating
1 Brass	Number above product picture always starting with 0				Can be added at an additional charge. Z No Plating G Gun Metal* 3 Gold* H Rhodium* R Rose Gold*

* Anti nickel allergenic

21 004 Baguette

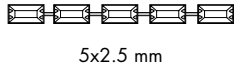

Stone Size		Ring Configuration		Back Configuration		Stone Art. No.
Code	Description	Code	Description	Code	Description	
05M	5x2.5 mm	00	None	C	Closed	4501

Back Configuration	
Code	Description
	Closed

21 004

Size 5x2.5 mm

Stock Program

21 004

Size 05M

Color/Plating

Crystal Z (001)

- Crystal**
- Crystal F (001)
- Colors**
- Plain Colors**
- Amethyst F (204)
- Aquamarine F (202)
- Black Diamond F (215)
- Jet F (280)
- Light Amethyst F (212)
- Light Sapphire F (211)
- Montana F (207)
- Peridot F (214)
- Rose F (209)
- Sapphire F (206)
- Siam F (208)
- Topaz F (203)
- Crystal Effects**
- Transparent Effects**
- Crystal AB F (001 AB)

21 OD4 Snake Chain

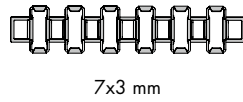
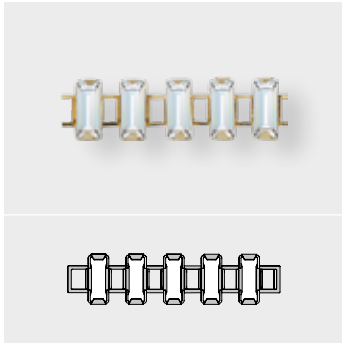

Stone Size		Ring Configuration		Back Configuration		Stone Art. No.
Code	Description	Code	Description	Code	Description	
07M	7x3 mm	00	None	C	Closed	4501

Back Configuration	
Code	Description
	Closed

21 OD4		Size	7x3 mm
Crystal			
<input type="radio"/>	Crystal F (001)		
Colors			
Plain Colors			
<input type="radio"/>	Amethyst F (204)		
<input type="radio"/>	Aquamarine F (202)		
<input type="radio"/>	Black Diamond F (215)		
<input type="radio"/>	Fuchsia F (502)		
<input type="radio"/>	Jet F (280)		
<input type="radio"/>	Light Amethyst F (212)		
<input type="radio"/>	Light Sapphire F (211)		
<input type="radio"/>	Montana F (207)		
<input type="radio"/>	Peridot F (214)		
<input type="radio"/>	Rose F (209)		
<input type="radio"/>	Sapphire F (206)		
<input type="radio"/>	Siam F (208)		
<input type="radio"/>	Topaz F (203)		
Crystal Effects			
Transparent Effects			
<input type="radio"/>	Crystal AB F (001 AB)		
<input type="radio"/>	Crystal Golden Shadow F (001 GSHA)		

Stock Program

21 OD4		Size	07M
Color/Plating			
<input type="radio"/>	Crystal 3 (001)		
<input type="radio"/>	Crystal H (001)		

02 095 Snake Chain Foldover

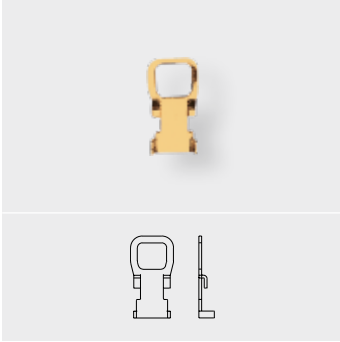

Base Item No.		Ring Configuration		Back Configuration		For Stone Size
Code	Description	Code	Description	Code	Description	
000	None	00	None	0	None	7x3 mm

05 955 Snake Chain Spring Ring

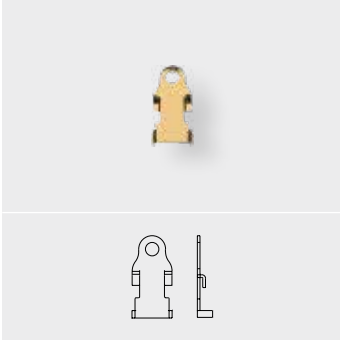

Base Item No.		Ring Configuration		Back Configuration		For Stone Size
Code	Description	Code	Description	Code	Description	
000	None	00	None	0	None	7x3 mm

23 004 Navette Chain

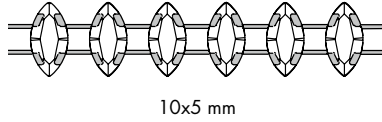

Stone Size		Ring Configuration		Back Configuration		Stone Art. No.
Code	Description	Code	Description	Code	Description	
10M	10x5 mm	00	None	C	Closed	4228

Back Configuration
Closed

23 004

Size 10x5 mm

- Crystal**
- Crystal F (001)
- Colors**
- Plain Colors**
- Amethyst F (204)
- Aquamarine F (202)
- Black Diamond F (215)
- Fuchsia F (502)
- Jet F (280)
- Light Amethyst F (212)
- Light Colorado Topaz F (246)
- Light Sapphire F (211)
- Light Siam F (227)
- Montana F (207)
- Peridot F (214)
- Purple Velvet F (277)
- Rose F (209)
- Sapphire F (206)
- Siam F (208)
- Topaz F (203)

23 004

Size 10x5 mm

- Opal Colors**
- Pacific Opal F (390)
- White Opal F (234)
- Crystal Effects**
- Transparent Effects**
- Crystal AB F (001 AB)
- Crystal Golden Shadow F (001 GSHA)
- Crystal Lilac Shadow F (001 LISH)
- Crystal Silver Shade F (001 SSHA)

27 000 Bezel Chain

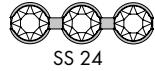
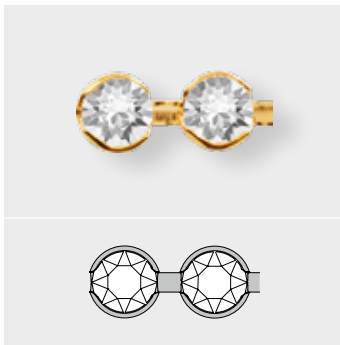

Stone Size		Ring Configuration		Back Configuration		Stone Art. No.
Code	Description	Code	Description	Code	Description	
P18	PP 18	00	None	C	Closed	1088
P24	PP 24	00	None	C	Closed	
P32	PP 32	00	None	C	Closed	
S24	SS 24	00	None	C	Closed	

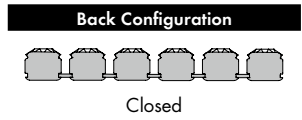

Cupchains & Findings

27 000		Size	PP 18	PP 24	PP 32	SS 24
Crystal						
Crystal F (001)			■	■	■	■
Colors						
Plain Colors						
Amethyst F (204)			■	■	■	■
Aquamarine F (202)			■	■	■	■
Black Diamond F (215)			■	■	■	■
Fuchsia F (502)			■	■	■	■
Indian Pink F (289)			■	■	■	■
Jet F (280)			■	■	■	■
Light Amethyst F (212)			■	■	■	■
Light Colorado Topaz F (246)			■	■	■	■
Light Sapphire F (211)			■	■	■	■
Light Siam F (227)			■	■	■	■
Montana F (207)			■	■	■	■
Peridot F (214)			■	■	■	■
Purple Velvet F (277)			■	■	■	■
Rose F (209)			■	■	■	■
Ruby F (501)			■	■	■	■
Sapphire F (206)			■	■	■	■
Siam F (208)			■	■	■	■
Silk F (391)			■	■	■	■
Smoky Quartz F (225)			■	■	■	■
Topaz F (203)			■	■	■	■
Opal Colors						
Pacific Opal F (390)			■	■	■	■
White Opal F (234)			■	■	■	■
Crystal Effects						
Transparent Effects						
Crystal AB F (001 AB)			■	■	■	■
Crystal Golden Shadow F (001 GSHA)			■	■	■	■
Crystal Lilac Shadow F (001 LISH)			■	■	■	■
Crystal Silver Shade F (001 SSHA)			■	■	■	■

Cupchains & Brass Components

27 000		Size	P18	P24	P32	S24
Color/Plating						
Crystal Z (001)			■	■	■	■
Crystal H (001)			■	■	■	■
Crystal 3 (001)			■	■	■	■

02 08B Bezel Crimp Foldover

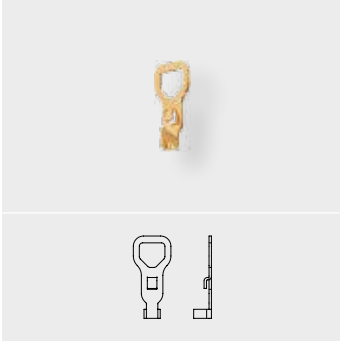

Base Item No.		Ring Configuration		Back Configuration		For Stone Size
Code	Description	Code	Description	Code	Description	
000	None	00	None	0	None	PP 32

05 81B Bezel Crimp Foldover

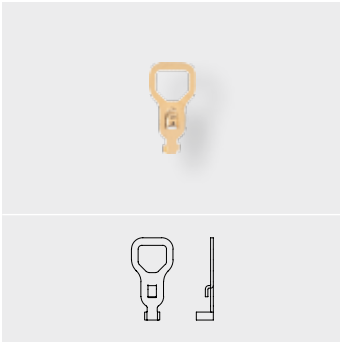

Base Item No.		Ring Configuration		Back Configuration		For Stone Size
Code	Description	Code	Description	Code	Description	
000	None	00	None	0	None	PP 24

05 82B Bezel Crimp Spring Ring

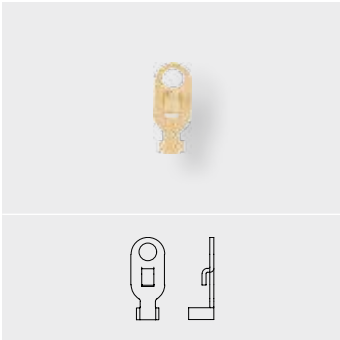

Base Item No.		Ring Configuration		Back Configuration		For Stone Size
Code	Description	Code	Description	Code	Description	
000	None	00	None	0	None	PP 24

05 83B Bezel Crimp Spring Ring

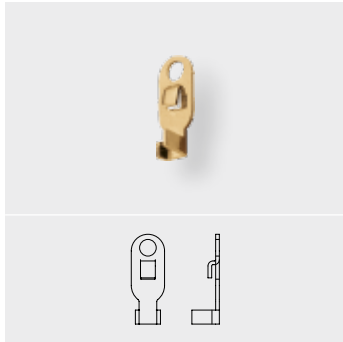

Base Item No.		Ring Configuration		Back Configuration		For Stone Size
Code	Description	Code	Description	Code	Description	
000	None	00	None	0	None	PP 32

05 94B Bezel Crimp Spring Ring

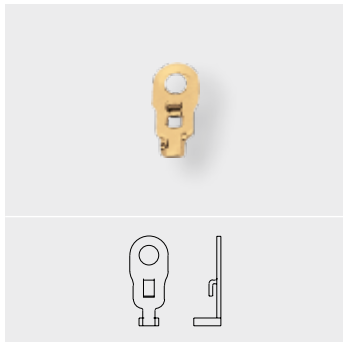

Base Item No.		Ring Configuration		Back Configuration		For Stone Size
Code	Description	Code	Description	Code	Description	
000	None	00	None	0	None	PP 18

07 41B Bezel Crimp Foldover

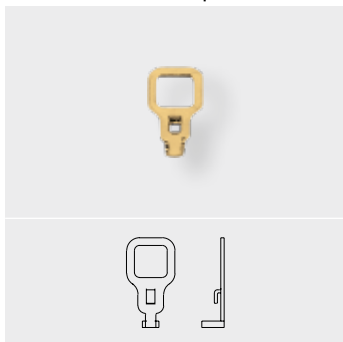

Base Item No.		Ring Configuration		Back Configuration		For Stone Size
Code	Description	Code	Description	Code	Description	
000	None	00	None	0	None	PP 18

Cupchains & Findings

Cupchains & Brass Components

27 001 Catch-free Cupchain



Stone Size		Ring Configuration		Back Configuration		Stone Art. No.
Code	Description	Code	Description	Code	Description	
P18	PP 18	00	None	C	Closed	1088
P24	PP 24	00	None	C	Closed	
P32	PP 32	00	None	C	Closed	

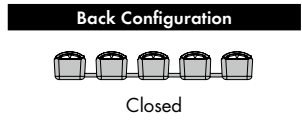

18 Cupchains & Findings Cupchains & Brass Components

27 001		Size	PP 18	PP 24	PP 32
Crystal					
Crystal F (001)			■	■	■
Colors					
Plain Colors					
Amethyst F (204)			■	■	■
Aquamarine F (202)			■	■	■
Black Diamond F (215)			■	■	■
Fuchsia F (502)			■	■	■
Indian Pink F (289)			■	■	■
Jet F (280)			■	■	■
Light Amethyst F (212)			■	■	■
Light Colorado Topaz F (246)			■	■	■
Light Sapphire F (211)			■	■	■
Light Siam F (227)			■	■	■
Montana F (207)			■	■	■
Peridot F (214)			■	■	■
Purple Velvet F (277)			■	■	■
Rose F (209)			■	■	■

27 001		Size	PP 18	PP 24	PP 32
Ruby F (501)			■	■	■
Sapphire F (206)			■	■	■
Siam F (208)			■	■	■
Silk F (391)			■	■	■
Smoky Quartz F (225)			■	■	■
Topaz F (203)			■	■	■
Opal Colors					
Pacific Opal F (390)			■	■	■
White Opal F (234)			■	■	■
Crystal Effects					
Transparent Effects					
Crystal AB F (001 AB)			■	■	■
Crystal Golden Shadow F (001 GSHA)			■	■	■
Crystal Lilac Shadow F (001 LISH)			■	■	■
Crystal Silver Shade F (001 SSHA)			■	■	■

27 004 Round

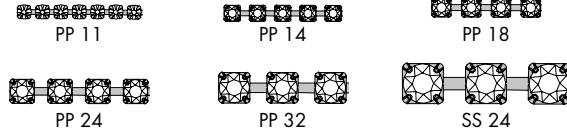



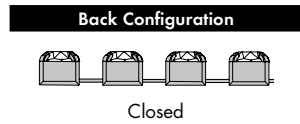











Stone Size		Ring Configuration		Back Configuration		Stone Art. No.	
Code	Description	Code	Description	Code	Description		
P11	PP 11	00	None	C	Closed	1028	1088
P14	PP 14	00	None	C	Closed		
P18	PP 18	00	None	C	Closed		
P24	PP 24	00	None	C	Closed		
P32	PP 32	00	None	C	Closed		
S24	SS 24	00	None	C	Closed		



27 004	Size	PP 11	PP 14	PP 18	PP 24	PP 32	SS 24
Crystal							
Crystal F (001)		■	■	■	■	■	■
Colors							
Plain Colors							
Amethyst F (204)		■	■	■	■	■	■
Aquamarine F (202)		■	■	■	■	■	■
Black Diamond F (215)		■	■	■	■	■	■
Fuchsia F (502)		■	■	■	■	■	■
Indian Pink F (289)		■	■	■	■	■	■
Jet F (280)		■	■	■	■	■	■
Light Amethyst F (212)		■	■	■	■	■	■
Light Colorado Topaz F (246)		■	■	■	■	■	■
Light Sapphire F (211)		■	■	■	■	■	■
Light Siam F (227)		■	■	■	■	■	■
Montana F (207)		■	■	■	■	■	■

Stock Program

27 004	Size	P11	P14	P18	P24	P32	S24
Color/Plating							
Crystal Z (001)		■	■	■	■	■	■
Crystal H (001)		■	■	■	■	■	■
Crystal 3 (001)		■	■	■	■	■	■
Crystal AB Z (001 AB)		■	■	■	■	■	■
Cr. Golden Shadow Z (001 GSHA)			■	■	■	■	■
Amethyst Z (204)			■	■	■	■	■
Aquamarine Z (202)			■	■	■	■	■
Black Diamond Z (215)		■	■	■	■	■	■
Jet Z (280)		■	■	■	■	■	■
Light Amethyst Z (212)			■	■	■	■	■
Light Colorado Topaz Z (246)			■	■	■	■	■
Montana Z (207)			■	■	■	■	■
Peridot Z (214)			■	■	■	■	■
Sapphire Z (206)			■	■	■	■	■
Siam Z (208)			■	■	■	■	■
Topaz Z (203)			■	■	■	■	■
White Opal Z (234)			■	■	■	■	■

27 004		Size	PP 11	PP 14	PP 18	PP 24	PP 32	SS 24
	Peridot F (214)		■	■	■	■	■	■
	Purple Velvet F (277)		■	■	■	■	■	■
	Rose F (209)		■	■	■	■	■	■
	Ruby F (501)		■	■	■	■	■	■
	Sapphire F (206)		■	■	■	■	■	■
	Siam F (208)		■	■	■	■	■	■
	Silk F (391)		■	■	■	■	■	■
	Smoky Quartz F (225)		■	■	■	■	■	■
	Topaz F (203)		■	■	■	■	■	■
Opal Colors								
	Pacific Opal F (390)		■	■	■	■	■	■
	White Opal F (234)		■	■	■	■	■	■
Crystal Effects								
Transparent Effects								
	Crystal AB F (001 AB)		■	■	■	■	■	■
	Crystal Golden Shadow F (001 GSHA)		■	■	■	■	■	■
	Crystal Lilac Shadow F (001 LISH)		■	■	■	■	■	■
	Crystal Silver Shade F (001 SSHA)		■	■	■	■	■	■

00 011 Crimp Foldover

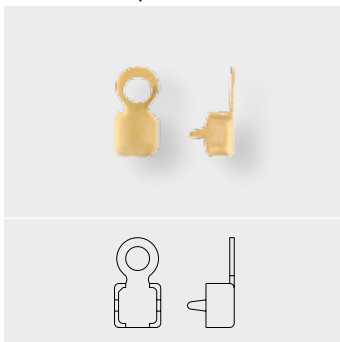

Base Item No.		Ring Configuration		Back Configuration		For Stone Size	
Code	Description	Code	Description	Code	Description		
000	None	00	None	0	None	PP 11	

00 248 Crimp Foldover

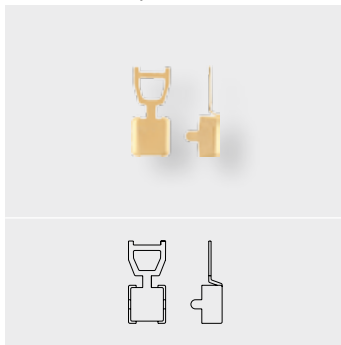

Base Item No.		Ring Configuration		Back Configuration		For Stone Size
Code	Description	Code	Description	Code	Description	
000	None	00	None	0	None	SS 24

00 286 Crimp Spring Ring

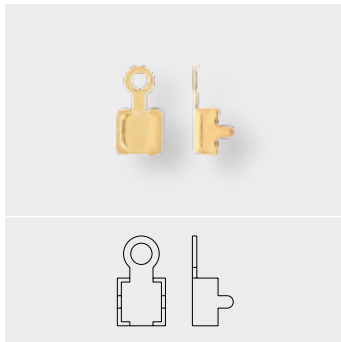

Base Item No.		Ring Configuration		Back Configuration		For Stone Size
Code	Description	Code	Description	Code	Description	
000	None	00	None	0	None	PP 14

00 582 Crimp Spring Ring

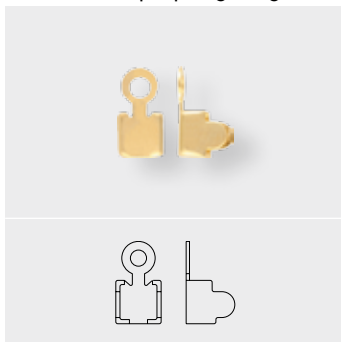

Base Item No.		Ring Configuration		Back Configuration		For Stone Size
Code	Description	Code	Description	Code	Description	
000	None	00	None	0	None	PP 24

Stock Program

00 582	For Stone Size	PP 24
Color/Plating		
Gold (3)	Rhodium (H)	

00 594 Crimp Spring Ring

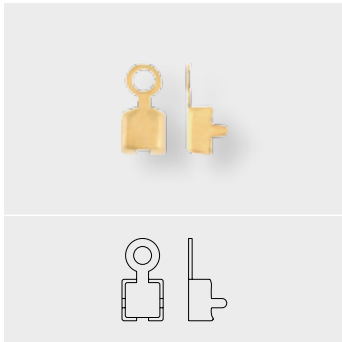

Base Item No.		Ring Configuration		Back Configuration		For Stone Size	
Code	Description	Code	Description	Code	Description		
000	None	00	None	0	None	PP 18	■

27 104 Round Extended

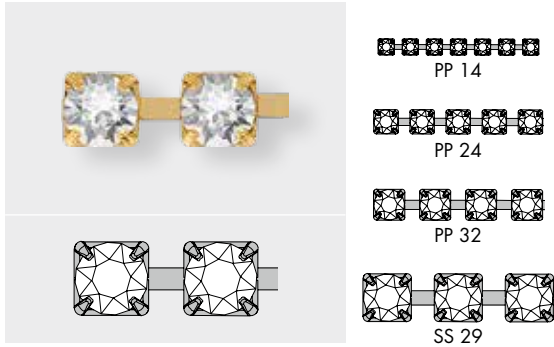

Stone Size		Ring Configuration		Back Configuration		Stone Art. No.
Code	Description	Code	Description	Code	Description	
P14	PP 14	00	None	C	Closed	1088
P24	PP 24	00	None	C	Closed	
P32	PP 32	00	None	C	Closed	
S29	SS 29	00	None	C	Closed	

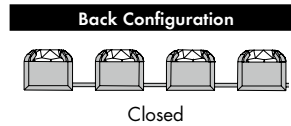

27 104	Size	PP 14	PP 24	PP 32	SS 29
		Crystal			
Crystal F (001)		■	■	■	■
Colors					
Plain Colors					
Amethyst F (204)		■	■	■	■
Aquamarine F (202)		■	■	■	■
Black Diamond F (215)		■	■	■	■
Fuchsia F (502)		■	■	■	■
Indian Pink F (289)		■	■	■	■
Jet F (280)		■	■	■	■
Light Amethyst F (212)		■	■	■	■
Light Colorado Topaz F (246)		■	■	■	■
Light Sapphire F (211)		■	■	■	■
Light Siam F (227)		■	■	■	■
Montana F (207)		■	■	■	■
Peridot F (214)		■	■	■	■
Purple Velvet F (277)		■	■	■	■

27 104	Size
	P14
	P24
	P32
	S29
Color/Plating	
Crystal Z (001)	■

27 104		Size	PP 14	PP 24	PP 32	SS 29
	Rose F (209)		■	■	■	■
	Ruby F (501)		■	■	■	■
	Sapphire F (206)		■	■	■	■
	Siam F (208)		■	■	■	■
	Silk F (391)		■	■	■	■
	Smoky Quartz F (225)		■	■	■	■
	Topaz F (203)		■	■	■	■
Opal Colors						
	Pacific Opal F (390)		■	■	■	■
	White Opal F (234)		■	■	■	■
Crystal Effects						
Transparent Effects						
	Crystal AB F (001 AB)		■	■	■	■
	Crystal Golden Shadow F (001 GSHA)		■	■	■	■
	Crystal Lilac Shadow F (001 LISH)		■	■	■	■
	Crystal Silver Shade F (001 SSHA)		■	■	■	■

00 029 Crimp Foldover

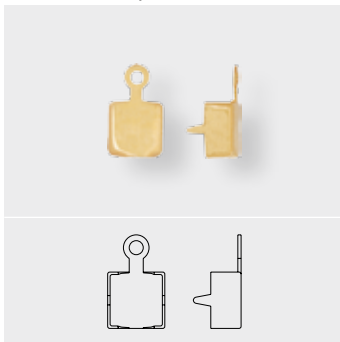

Base Item No.		Ring Configuration		Back Configuration		For Stone Size	
Code	Description	Code	Description	Code	Description		
000	None	00	None	0	None	SS 29	■

00 286 Crimp Spring Ring

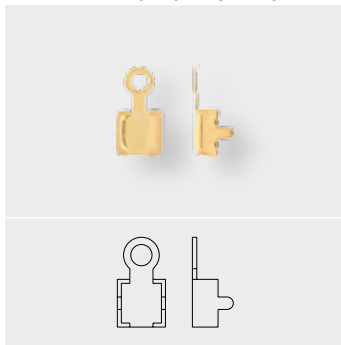

Base Item No.		Ring Configuration		Back Configuration		For Stone Size
Code	Description	Code	Description	Code	Description	
000	None	00	None	0	None	PP 14

00 582 Crimp Spring Ring

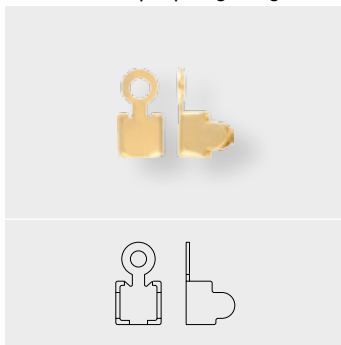

Base Item No.		Ring Configuration		Back Configuration		For Stone Size
Code	Description	Code	Description	Code	Description	
000	None	00	None	0	None	PP 24

00 594 Crimp Spring Ring

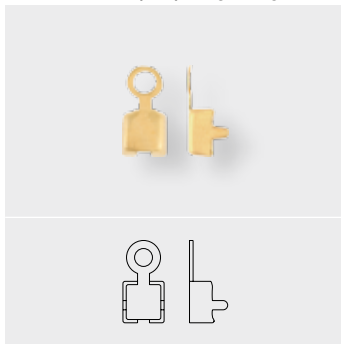

Base Item No.		Ring Configuration		Back Configuration		For Stone Size
Code	Description	Code	Description	Code	Description	
000	None	00	None	0	None	PP 18

27 2R4 Round String

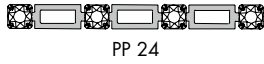
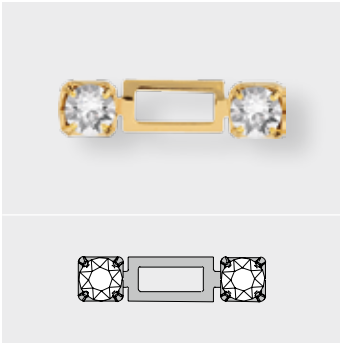

Stone Size		Ring Configuration		Back Configuration		Stone Art. No.
Code	Description	Code	Description	Code	Description	
P24	PP 24	00	None	C	Closed	1088

Back Configuration	
Code	Description
	Closed



- Crystal**
- Crystal F (001)
- Colors**
- Plain Colors**
- Amethyst F (204)
- Aquamarine F (202)
- Black Diamond F (215)
- Fuchsia F (502)
- Indian Pink F (289)
- Jet F (280)
- Light Amethyst F (212)
- Light Colorado Topaz F (246)
- Light Sapphire F (211)
- Light Siam F (227)
- Montana F (207)
- Peridot F (214)
- Purple Velvet F (277)

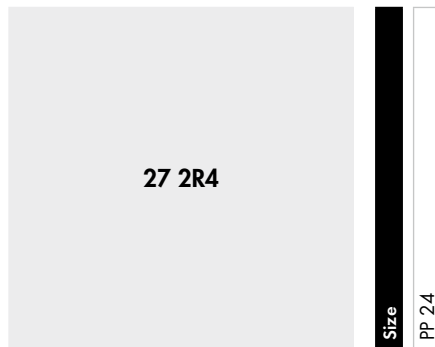

- Rose F (209)
- Ruby F (501)
- Sapphire F (206)
- Siam F (208)
- Silk F (391)
- Smoky Quartz F (225)
- Topaz F (203)
- Opal Colors**
- Pacific Opal F (390)
- White Opal F (234)
- Crystal Effects**
- Transparent Effects**
- Crystal AB F (001 AB)
- Crystal Golden Shadow F (001 GSHA)
- Crystal Lilac Shadow F (001 LISH)
- Crystal Silver Shade F (001 SSHA)

00 582 Crimp Spring Ring

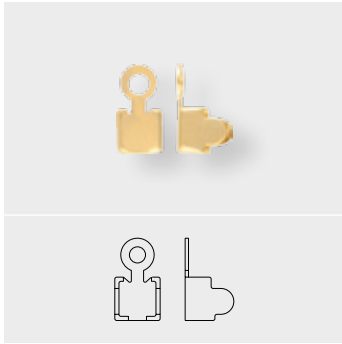

Base Item No.		Ring Configuration		Back Configuration		For Stone Size
Code	Description	Code	Description	Code	Description	
000	None	00	None	0	None	PP 24

27 308 Round Tiffany

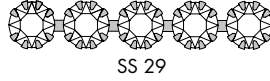
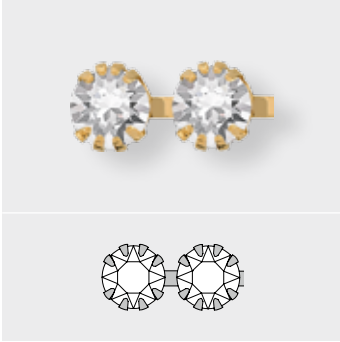

Stone Size		Ring Configuration		Back Configuration		Stone Art. No.
Code	Description	Code	Description	Code	Description	
S29	SS 29	00	None	C	Closed	1088

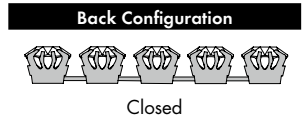

27 308

Size SS 29

- Crystal**
- Crystal F (001)
- Colors**
- Plain Colors**
- Amethyst F (204)
- Aquamarine F (202)
- Black Diamond F (215)
- Fuchsia F (502)
- Indian Pink F (289)
- Jet F (280)
- Light Amethyst F (212)
- Light Colorado Topaz F (246)
- Light Sapphire F (211)
- Light Siam F (227)
- Montana F (207)
- Peridot F (214)
- Purple Velvet F (277)

27 308

Size SS 29

- Rose F (209)
- Ruby F (501)
- Sapphire F (206)
- Siam F (208)
- Silk F (391)
- Smoky Quartz F (225)
- Topaz F (203)
- Opal Colors**
- Pacific Opal F (390)
- White Opal F (234)
- Crystal Effects**
- Transparent Effects**
- Crystal AB F (001 AB)
- Crystal Golden Shadow F (001 GSHA)
- Crystal Lilac Shadow F (001 LISH)
- Crystal Silver Shade F (001 SSHA)

Stock Program

27 308	Size S29
Color/Plating	
Crystal Z (001)	<input type="checkbox"/>
Crystal 3 (001)	<input type="checkbox"/>

00 029 Crimp Foldover

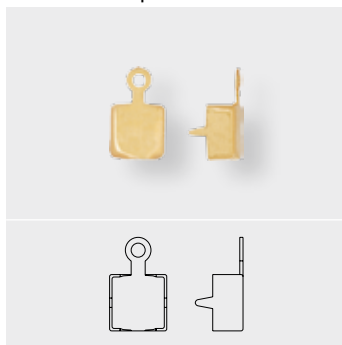

Base Item No.		Ring Configuration		Back Configuration		For Stone Size
Code	Description	Code	Description	Code	Description	
000	None	00	None	0	None	SS 29

28 002 Square

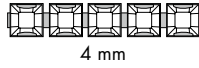
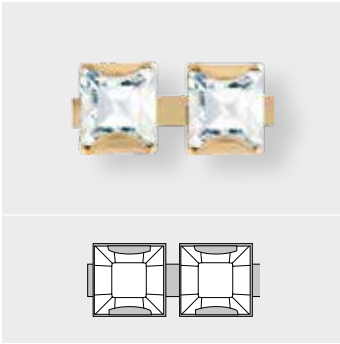

Stone Size		Ring Configuration		Back Configuration		Stone Art. No.
Code	Description	Code	Description	Code	Description	
04M	4 mm	00	None	C	Closed	4428

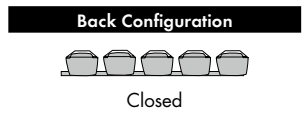

28 002

Size 4 mm

- Crystal**
 - Crystal F (001)
- Colors**
- Plain Colors**
 - Amethyst F (204)
 - Aquamarine F (202)
 - Black Diamond F (215)
 - Fuchsia F (502)
 - Jet (280)
 - Light Amethyst F (212)
 - Light Colorado Topaz F (246)
 - Light Sapphire F (211)
 - Light Siam F (227)
 - Montana F (207)
 - Peridot F (214)
 - Rose F (209)
 - Sapphire F (206)
 - Siam F (208)
 - Smoky Quartz F (225)
 - Topaz F (203)
- Opal Colors**
 - White Opal F (234)

28 002

Size 4 mm

- Crystal Effects**
- Transparent Effects**
 - Crystal AB F (001 AB)
 - Crystal Golden Shadow F (001 GSHA)
 - Crystal Lilac Shadow F (001 LISH)
 - Crystal Silver Shade F (001 SSHA)

Stock Program

28 002

Size 04M

- Color/Plating**
 - Crystal Z (001)
 - Crystal H (001)
 - Jet Z (280)

00 256 Crimp Foldover

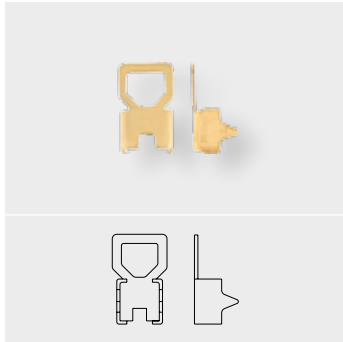

Base Item No.		Ring Configuration		Back Configuration		For Stone Size
Code	Description	Code	Description	Code	Description	
000	None	00	None	0	None	4 mm

00 578 Solder End

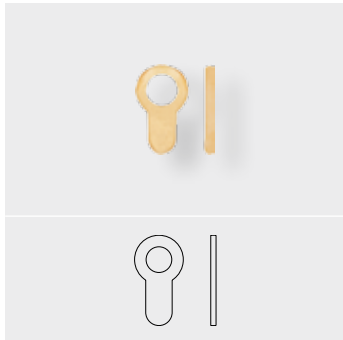

Base Item No.		Ring Configuration		Back Configuration	
Code	Description	Code	Description	Code	Description
000	None	00	None	0	None

01 013 Foldover Raw

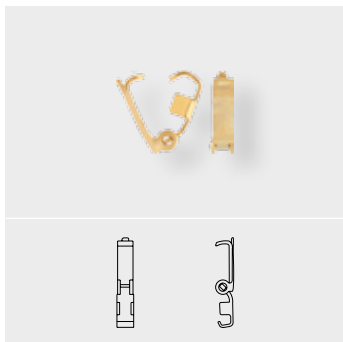

Base Item No.		Ring Configuration		Back Configuration	
Code	Description	Code	Description	Code	Description
000	None	00	None	0	None

01 014 Solder End

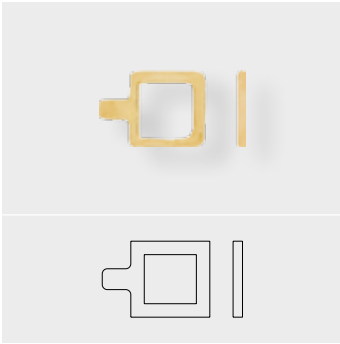

Base Item No.		Ring Configuration		Back Configuration	
Code	Description	Code	Description	Code	Description
000	None	00	None	0	None

01 255 Lobster Claw Small

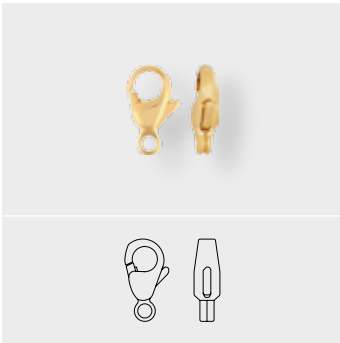

Base Item No.		Ring Configuration		Back Configuration	
Code	Description	Code	Description	Code	Description
000	None	00	None	0	None

01 256 Lobster Claw Large

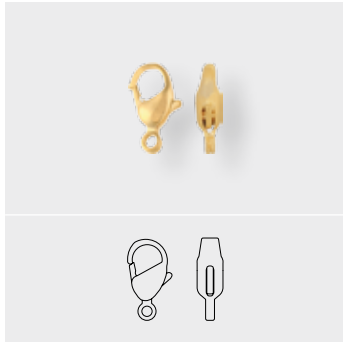

Base Item No.		Ring Configuration		Back Configuration	
Code	Description	Code	Description	Code	Description
000	None	00	None	0	None

Stock Program

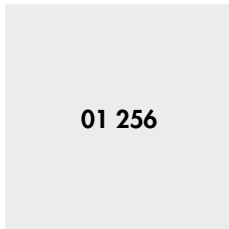

Color/Plating
Gold (3)

PRODUCT DETAILS

Article Stone Article Number	Stone Size	Stones per meter	Stones per foot
21 004			
4501	5x2.5 mm	143	44
21 0D4			
4501	7x3 mm	186	57
23 004			
4228	10x5 mm	128	39
27 000			
1088	PP 18	273	83
1088	PP 24	220	67
1088	PP 32	171	52
1088	SS 24	139	42
27 001			
1088	PP 18	275	84
1088	PP 24	223	68
1088	PP 32	177	54
27 004			
1028	PP 11	392	119
1088	PP 14	344	105
1088	PP 18	273	83
1088	PP 24	222	68
1088	PP 32	169	52
1088	SS 24	139	42
27 104			
1088	PP 14	326	99
1088	PP 24	201	61
1088	PP 32	157	48
1088	SS 29	132	41
27 2R4			
1088	PP 24	99	30
27 308			
1088	SS 29	125	38
28 002			
4428	4 mm	204	62

MULTI STONE SETTINGS

These products incorporate Round or Fancy Stones, set in special metal forms such as circles, crosses or balls. Stretch Bracelets are also part of this group.

ARTICLE EXPLANATION - BASE ITEM NUMBER

37 E00 Bezel Stretch Chain

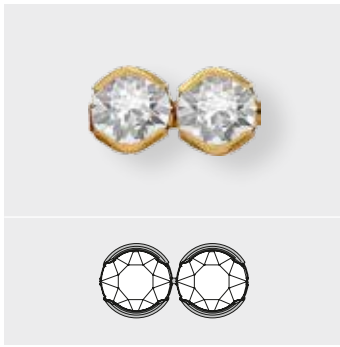

3	7	E	00
Product category	Stone code (type of stone used)	Setting code	Number of prongs or stones in the setting (always 2 digit code)
3 Multi Stone Settings	1 Baguette 7 Round 8 Square	E Stretch Chain 1 Double Setting 7 Circle	00 Bezel 02 04 08 14 20

ORDERING EXAMPLE & PRODUCT VARIETY EXPLANATION

1	37 E00	P32	18	C
Material type	Base item number	Stone size	Ring configuration	Back configuration
1 Brass		3-digit code from respective product matrix.	00 None 18 18 cm 1T 1 Ring/Top	1 Channel C Closed O Open
>> F1	G	1088	F	220
Stone pattern	Plating	Base item art. no.	Foiling	Color of crystal
F1 Crystal/color/effect	Can be added at an additional charge Z No Plating G Gun Metal* 3 Gold* H Rhodium* R Rose Gold* Stretch articles 31 E02, 37 E00, 37 E04 and 38 E02 are only available with plating.	1088 4428 4501	F Foiled	Please see the respective color chart at the beginning of this chapter for all available code references.

* Anti nickel allergenic

Not all configurations are available for all articles. Please refer to the respective product matrix for available combinations.

ARTICLE EXPLANATION – BASE ITEM NUMBER

41 205 Cross Baguette

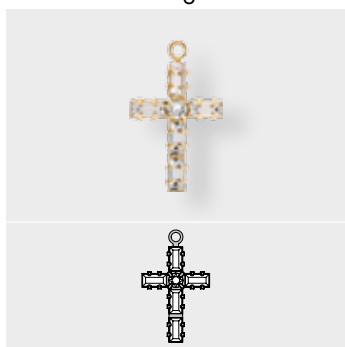

4	1	2	05
Product category	Stone code (type of stone used)	Setting code	Number of stones in the setting (always 2-digit code)
4 Fancy Multi Settings	1 Baguette 7 Round	2 Cross 4 Rondelle Ball 5 Ball 6 Graduated	03 05 08 10 12

ORDERING EXAMPLE & PRODUCT VARIETY EXPLANATION

1	41 205	04M	1T	C
Material type	Base item number	Stone size	Ring configuration	Back configuration
1 Brass		3-digit code from respective product matrix	00 None 1T 1 Ring/Top TB 2 Rings/Top & Bottom	C Closed H Hole (1 mm)
>> F1	S	1088	F	001 AB
Stone pattern	Plating	Base item art. no.	Foiling	Color of crystal
F1 Crystal/color/effect	Can be added at an additional charge. Z No Plating G Gun Metal* 3 Gold* H Rhodium* R Rose Gold*	1088 4501	F Foiled	Please see the respective color chart at the beginning of this chapter for all available code references.

* Anti nickel allergenic

31 E02 Snake Chain Stretch Bracelet

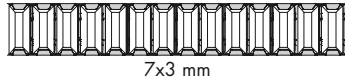

Stone Size		Ring Configuration		Back Configuration		Stone Art. No.	Diameter
Code	Description	Code	Description	Code	Description	4501	55.0 mm
07M	7x3 mm	18	170.0 mm	C	Closed		

Back Configuration



31 E02

Size 7x3 mm

- Crystal**
- Crystal F (001)
- Colors**
- Plain Colors**
- Amethyst F (204)
- Aquamarine F (202)
- Black Diamond F (215)
- Fuchsia F (502)
- Jet F (280)
- Light Amethyst F (212)
- Light Sapphire F (211)
- Sapphire F (206)
- Siam F (208)
- Smoky Quartz F (225)
- Tanzanite F (539)
- Violet F (371)
- Crystal Effects**
- Transparent Effects**
- Crystal AB F (001 AB)
- Crystal Golden Shadow F (001 GSHA)
- Crystal Silver Shade F (001 SSHA)

Stock Program

31 E02

Size 07M 18 C

Color/Plating

- Crystal H (001)
- Jet H (280)

37 E00 Bezel Stretch Chain

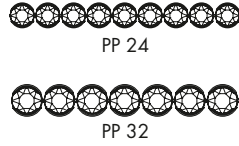
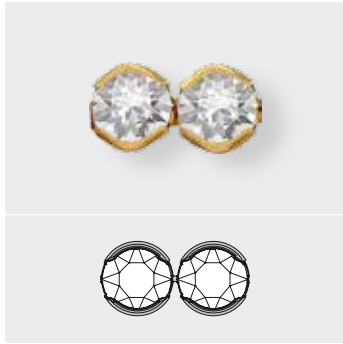

Stone Size		Ring Configuration		Back Configuration		Stone Art. No.	Diameter	
Code	Description	Code	Description	Code	Description	1088		
P24	PP 24	18	177.8 mm	C	Closed		■	54.0 mm
P32	PP 32	18	170 mm	C	Closed		■	55.0 mm

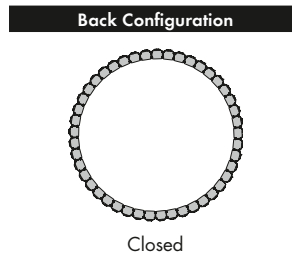

37 E00

Size

PP 24

PP 32

Crystal

- Crystal F (001)

Colors

Plain Colors

- Amethyst F (204)
- Aquamarine F (202)
- Black Diamond F (215)
- Chrysolite F (238)
- Denim Blue F (266)
- Fuchsia F (502)
- Jet F (280)
- Light Colorado Topaz F (246)
- Light Rose F (223)
- Light Sapphire F (211)
- Sapphire F (206)
- Siam F (208)

Stock Program

37 E00

Size

P32 18 C

Color/Plating

- Crystal H (001)
- Crystal 3 (001)

37 E00

Size: PP 24, PP 32

- Smoky Quartz F (225)
- Tanzanite F (539)
- Violet F (371)
- Opal Colors
- White Opal F (234)
- Crystal Effects
- Transparent Effects
- Crystal AB F (001 AB)
- Crystal Golden Shadow F (001 GSHA)
- Crystal Lilac Shadow F (001 LISH)
- Crystal Silver Shade F (001 SSHA)

37 E04 Stretch Chain





PP 24



PP 32

Stone Size		Ring Configuration		Back Configuration		Stone Art. No.	Diameter
Code	Description	Code	Description	Code	Description		
P24	PP 24	18	177.8 mm	C	Closed	1088	55.1 mm
P32	PP 32	18	173.0 mm	C	Closed		53.3 mm

Back Configuration



Cupchains & Findings

37 E04

Size
PP 24 PP 32

Crystal

Crystal F (001)

Colors

Plain Colors

Amethyst F (204)

Aquamarine F (202)

Black Diamond F (215)

Chrysolite F (238)

Denim Blue F (266)

Fuchsia F (502)

Jet F (280)

Light Colorado Topaz F (246)

Light Rose F (223)

Light Sapphire F (211)

Sapphire F (206)

Siam F (208)

Smoky Quartz F (225)

Tanzanite F (539)

Violet F (371)

Opal Colors

White Opal F (234)

Crystal Effects

Transparent Effects

Crystal AB F (001 AB)

Crystal Golden Shadow F (001 GSHA)

Crystal Lilac Shadow F (001 LISH)

Crystal Silver Shade F (001 SSHA)

Multi Stone Settings

Stock Program

37 E04

Size
P24 18 C P32 18 C

Color/Plating

Crystal H (001)

Crystal 3 (001)

Crystal AB H (001AB)

Amethyst H (204)

Aquamarine H (202)

Light Rose H (223)

Rose H (209)

37 102 Double Setting



SS 39

Stone Size		Ring Configuration		Back Configuration		Stone Art. No.		Dimensions
Code	Description	Code	Description	Code	Description			
S39	SS 19, SS 39	1T	1R, Top	C	Closed	1088	1088	115.8x71.1 mm

Ring Configuration



1T

37 102

Size

SS 19

SS 39

- Crystal**
- Crystal F (001)
- Colors**
- Plain Colors**
- Amethyst F (204)
- Aquamarine F (202)
- Black Diamond F (215)
- Chrysolite F (238)
- Denim Blue F (266)
- Fuchsia F (502)
- Jet F (280)
- Light Colorado Topaz F (246)
- Light Rose F (223)
- Light Sapphire F (211)
- Sapphire F (206)
- Siam F (208)
- Smoky Quartz F (225)
- Tanzanite F (539)
- Violet F (371)
- Opal Colors**
- White Opal F (234)

37 102

Size

SS 19

SS 39

- Crystal Effects**
- Transparent Effects**
- Crystal AB F (001 AB)
- Crystal Golden Shadow F (001 GSHA)
- Crystal Lilac Shadow F (001 LISH)
- Crystal Silver Shade F (001 SSHA)

Stock Program

37 102

Size

S39 1T C

Color/Plating

Crystal H (001)

37 708 Circle

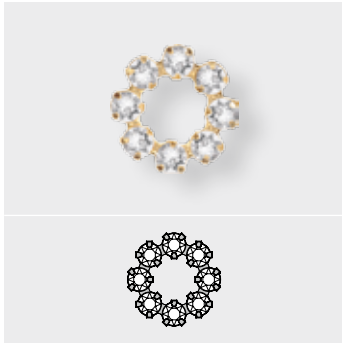

Stone Size		Ring Configuration		Back Configuration		Stone Art. No.	Diameter
Code	Description	Code	Description	Code	Description	1088	10 mm
P18	PP 18	00	None	O	Open		

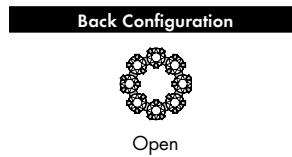

37 708

Size PP 18

- Crystal**
- Crystal F (001)
- Colors**
- Plain Colors**
- Amethyst F (204)
- Aquamarine F (202)
- Black Diamond F (215)
- Chrysolite F (238)
- Denim Blue F (266)
- Fuchsia F (502)
- Jet F (280)
- Light Colorado Topaz F (246)
- Light Rose F (223)
- Light Sapphire F (211)
- Sapphire F (206)
- Siam F (208)
- Smoky Quartz F (225)
- Tanzanite F (539)
- Violet F (371)
- Opal Colors**
- White Opal F (234)

37 708

Size PP 18

- Crystal Effects**
- Transparent Effects**
- Crystal AB F (001 AB)
- Crystal Golden Shadow F (001 GSHA)
- Crystal Lilac Shadow F (001 LISH)
- Crystal Silver Shade F (001 SSHA)

37 714 Circle

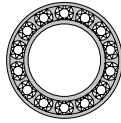
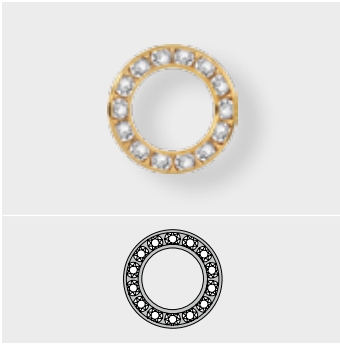

PP 18
15.6 mm

Stone Size		Ring Configuration		Back Configuration		Stone Art. No.	Diameter
Code	Description	Code	Description	Code	Description	1088	15.6 mm
P18	PP 18	00	None	1	Channel		

Back Configuration

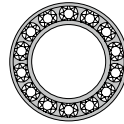

Channel

37 714

Size PP 18

- Crystal**
 - Crystal F (001)
- Colors**
- Plain Colors**
 - Amethyst F (204)
 - Aquamarine F (202)
 - Black Diamond F (215)
 - Chrysolite F (238)
 - Denim Blue F (266)
 - Fuchsia F (502)
 - Jet F (280)
 - Light Colorado Topaz F (246)
 - Light Rose F (223)
 - Light Sapphire F (211)
 - Sapphire F (206)
 - Siam F (208)
 - Smoky Quartz F (225)
 - Tanzanite F (539)
 - Violet F (371)

37 714

Size PP 18

- Opal Colors**
 - White Opal F (234)
- Crystal Effects**
- Transparent Effects**
 - Crystal AB F (001 AB)
 - Crystal Golden Shadow F (001 GSHA)
 - Crystal Lilac Shadow F (001 LISH)
 - Crystal Silver Shade F (001 SSHA)

Stock Program

37 714

Size P18 00 1

Color/Plating

- Crystal H (001)

37 720 Circle



PP 18
21.4 mm

Stone Size		Ring Configuration		Back Configuration		Stone Art. No.	Diameter
Code	Description	Code	Description	Code	Description	1088	21.4 mm
P18	PP 18	00	None	1	Channel		

Back Configuration

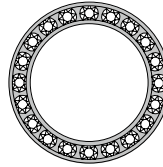

Channel

37 720

Size PP 18

- Crystal**
- Crystal F (001)
- Colors**
- Plain Colors**
- Amethyst F (204)
- Aquamarine F (202)
- Black Diamond F (215)
- Chrysolite F (238)
- Denim Blue F (266)
- Fuchsia F (502)
- Jet (280)
- Light Colorado Topaz F (246)
- Light Rose F (223)
- Light Sapphire F (211)
- Sapphire F (206)
- Siam F (208)
- Smoky Quartz F (225)
- Tanzanite F (539)
- Violet F (371)

37 720

Size PP 18

- Opal Colors**
- White Opal F (234)
- Crystal Effects**
- Transparent Effects**
- Crystal AB F (001 AB)
- Crystal Golden Shadow F (001 GSHA)
- Crystal Lilac Shadow F (001 LISH)
- Crystal Silver Shade F (001 SSHA)

Stock Program

37 720

Size P18 00 1

- Color/Plating**
- Crystal H (001)
- Crystal Z (001)

38 E02 Square Stretch Chain

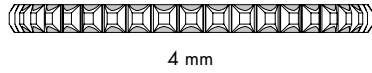
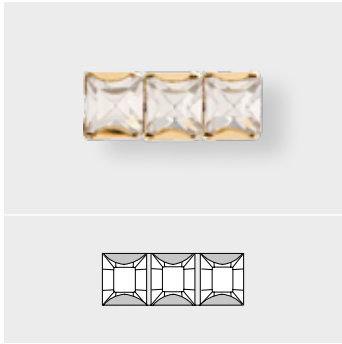

Stone Size		Ring Configuration		Back Configuration		Stone Art. No.	Diameter
Code	Description	Code	Description	Code	Description	4428	55.0 mm
04M	4 mm	18	170.0 mm	C	Closed		

Back Configuration

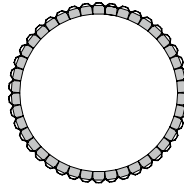

Closed

38 E02

Size 4 mm

- Crystal**
 - Crystal F (001)
- Colors**
 - Plain Colors**
 - Amethyst F (204)
 - Aquamarine F (202)
 - Black Diamond F (215)
 - Chrysolite F (238)
 - Denim Blue F (266)
 - Fuchsia F (502)
 - Jet F (280)
 - Light Colorado Topaz F (246)
 - Light Rose F (223)
 - Light Sapphire F (211)
 - Sapphire F (206)
 - Siam F (208)
 - Smoky Quartz F (225)
 - Tanzanite F (539)
 - Violet F (371)

38 E02

Size 4 mm

- Opal Colors**
 - White Opal F (234)
- Crystal Effects**
 - Transparent Effects**
 - Crystal AB F (001 AB)
 - Crystal Golden Shadow F (001 GSHA)
 - Crystal Lilac Shadow F (001 LISH)
 - Crystal Silver Shade F (001 SSHA)

Stock Program

38 E02

Size 04M 18 C

Color/Plating

- Crystal H (001)

41 205 Cross Baguette

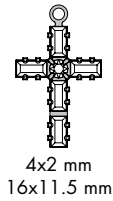
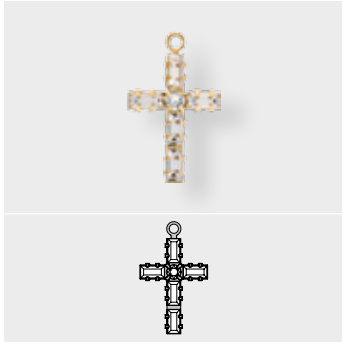

Stone Size		Ring Configuration		Back Configuration		Stone Art. No.		Dimensions
Code	Description	Code	Description	Code	Description	4501	1088	
04M	4x2 mm, PP 18	1T	1R, Top	C	Closed			16x11.5 mm

41 205

Size 4x2 mm PP 18

- Crystal**
- Crystal F (001)
- Colors**
- Plain Colors**
- Amethyst F (204)
 - Aquamarine F (202)
 - Black Diamond F (215)
 - Chrysolite F (238)
 - Denim Blue F (266)
 - Fuchsia F (502)
 - Jet F (280)
 - Light Colorado Topaz F (246)
 - Light Rose F (223)
 - Light Sapphire F (211)
 - Sapphire F (206)
 - Siam F (208)
 - Smoky Quartz F (225)
 - Tanzanite F (539)
 - Violet F (371)
- Opal Colors**
- White Opal F (234)

41 205

Size 4x2 mm PP 18

- Crystal Effects**
- Transparent Effects**
- Crystal AB F (001 AB)
 - Crystal Golden Shadow F (001 GSHA)
 - Crystal Lilac Shadow F (001 LISH)
 - Crystal Silver Shade F (001 SSHA)

47 408 Rondelle 8 mm Ball

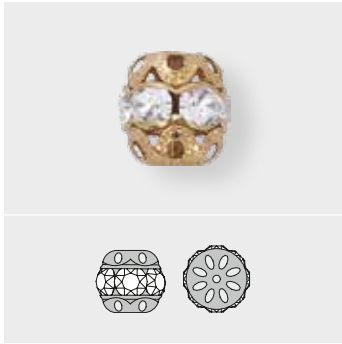

PP 28
8 mm

Stone Size		Ring Configuration		Back Configuration		Stone Art. No.	Outside Diameter
Code	Description	Code	Description	Code	Description		
P28	PP 28	00	None	C	Closed	1088	8 mm

47 408

Size

PP 28

47 408

Size

P28 00 C

Color/Plating

Crystal Z (001) ■

Crystal H (001) ■

- Crystal**
- Crystal F (001) ■
- Colors**
- Plain Colors**
- Amethyst F (204) ■
- Aquamarine F (202) ■
- Black Diamond F (215) ■
- Fuchsia F (502) ■
- Jet F (280) ■
- Light Colorado Topaz F (246) ■
- Light Rose F (223) ■
- Light Sapphire F (211) ■
- Sapphire F (206) ■
- Siam F (208) ■
- Tanzanite F (539) ■
- Violet F (371) ■
- Crystal Effects**
- Transparent Effects**
- Crystal AB F (001 AB) ■

47 510 Ball 10 mm Round

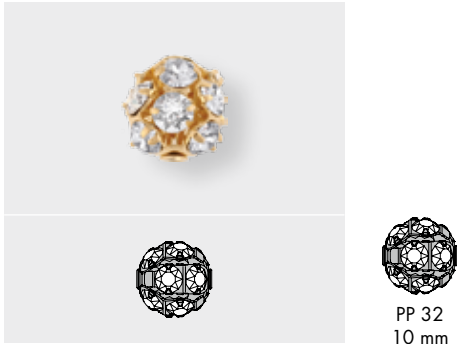

Stone Size		Ring Configuration		Back Configuration		Stone Art. No.	Outside Diameter
Code	Description	Code	Description	Code	Description		
P32	PP 32	00	None	H	Hole	1088	10 mm

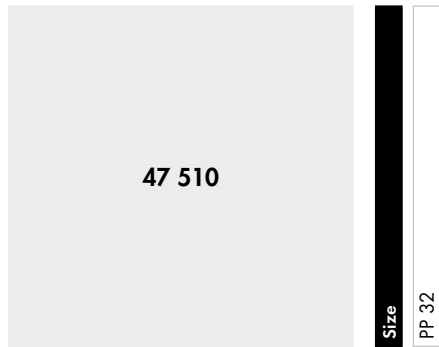

Crystal

Crystal F (001)

Colors

Plain Colors

- Amethyst F (204)
- Aquamarine F (202)
- Black Diamond F (215)
- Chrysolite F (238)
- Denim Blue F (266)
- Fuchsia F (502)
- Jet F (280)
- Light Colorado Topaz F (246)
- Light Rose F (223)
- Light Sapphire F (211)
- Sapphire F (206)
- Siam F (208)
- Smoky Quartz F (225)
- Tanzanite F (539)
- Violet F (371)

Opal Colors

White Opal F (234)

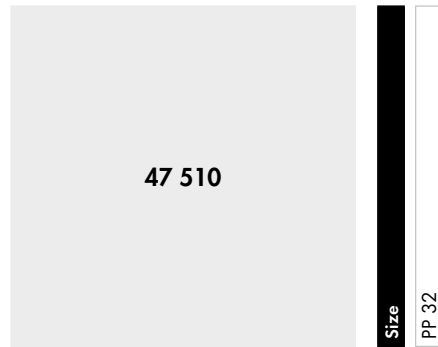

Crystal Effects

Transparent Effects

- Crystal AB F (001 AB)
- Crystal Golden Shadow F (001 GSHA)
- Crystal Lilac Shadow F (001 LISH)
- Crystal Silver Shade F (001 SSHA)

Stock Program

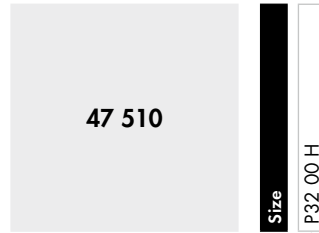

Color/Plating

Crystal H (001)

47 512 Ball 12 mm Round

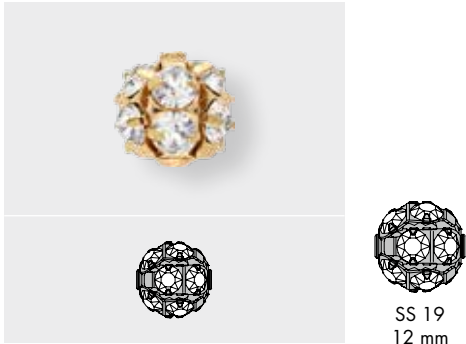

Stone Size		Ring Configuration		Back Configuration		Stone Art. No.	Outside Diameter
Code	Description	Code	Description	Code	Description	1088	
S19	SS 19	00	None	H	Hole		12 mm

47 512

Size SS 19 (12 mm)

- Crystal**
- Crystal F (001)
- Colors**
- Plain Colors**
- Amethyst F (204)
 - Aquamarine F (202)
 - Black Diamond F (215)
 - Chrysolite F (238)
 - Denim Blue F (266)
 - Fuchsia F (502)
 - Jet F (280)
 - Light Colorado Topaz F (246)
 - Light Rose F (223)
 - Light Sapphire F (211)
 - Sapphire F (206)
 - Siam F (208)
 - Smoky Quartz F (225)
 - Tanzanite F (539)
 - Violet F (371)
- Opal Colors**
- White Opal F (234)

47 512

Size SS 19 (12 mm)

- Crystal Effects**
- Transparent Effects**
- Crystal AB F (001 AB)
 - Crystal Golden Shadow F (001 GSHA)
 - Crystal Lilac Shadow F (001 LISH)
 - Crystal Silver Shade F (001 SSHA)

Stock Program

47 512

Size S19 00 H

Color/Plating

- Crystal H (001)

47 603 Graduated Setting Round

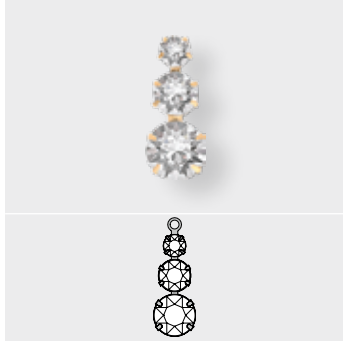

SS 19, SS 29, SS 39
20.4 mm

Stone Size		Ring Configuration		Back Configuration		Stone Art. No.			Outside Diameter
Code	Description	Code	Description	Code	Description				
S19	SS 19, SS 29, SS 39	1T	1R, Top	C	Closed	1088	1088	1088	20.4 mm

Ring Configuration

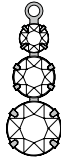

1T

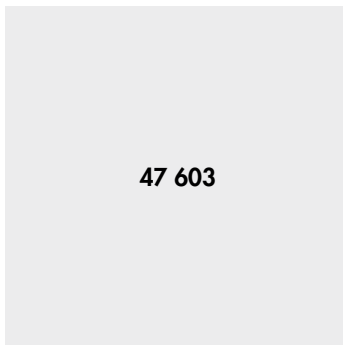

47 603

Size
4 mm

Crystal

Crystal F (001)

Colors

Plain Colors

- Amethyst F (204)
- Aquamarine F (202)
- Black Diamond F (215)
- Chrysolite F (238)
- Denim Blue F (266)
- Fuchsia F (502)
- Jet F (280)
- Light Colorado Topaz F (246)
- Light Rose F (223)
- Light Sapphire F (211)
- Sapphire F (206)
- Siam F (208)
- Smoky Quartz F (225)
- Tanzanite F (539)
- Violet F (371)

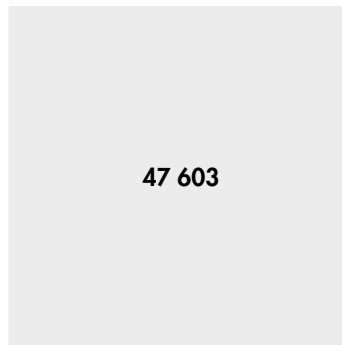

47 603

Size
4 mm

Opal Colors

White Opal F (234)

Crystal Effects

Transparent Effects

- Crystal AB F (001 AB)
- Crystal Golden Shadow F (001 GSHA)
- Crystal Lilac Shadow F (001 LISH)
- Crystal Silver Shade F (001 SSHA)

Stock Program

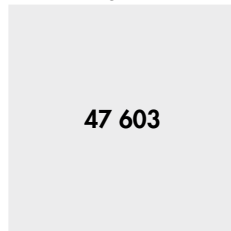

47 603

Size
S19 1T C

Color/Plating

Crystal H (001)

CHANNELS

These products are single Round or Fancy Stones without foiling that are fitted with a metal ring around the girdle of the stone. This gives the channels their typical feature: the wearer is able to look "through" the Round or Fancy Stones.

ARTICLE EXPLANATION - BASE ITEM NUMBER

57 700 Round

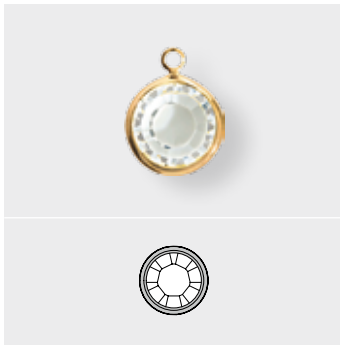

5	7	7	00
Product category	Stone code (type of stone used)	Setting code	Number of stones in the setting (always 2-digit code)
5 Channels	3 Navette 5 Oval 7 Round	3 Navette 5 Oval 7 Round	00

ORDERING EXAMPLE & PRODUCT VARIETY EXPLANATION

1	57 700	P32	TB	O
Material type	Base item number	Stone size	Ring configuration	Back configuration
1 Brass		3-digit code from respective product matrix	1T 1 Ring/Top TB 2 Rings/Top & Bottom	O Open
F1	3	1128	542	
Stone pattern	Plating	Base item art. no.	Color of crystal	
F1 Crystal/color/effect	Can be added at an additional charge. Z No Plating G Gun Metal* 3 Gold* H Rhodium* R Rose Gold*	1128 4128 4228	Please see the respective color chart at the beginning of this chapter for all available code references.	

* Anti nickel allergenic

53 300 Navette



Stone Size		Ring Configuration		Back Configuration		Stone Art. No.
Code	Description	Code	Description	Code	Description	
10M	10x5 mm	1T	1R, Top	○	Open	4228
10M	10x5 mm	TB	2R, Top/Bottom	○	Open	

Ring Configuration		Back Configuration	
1T	TB	Open	

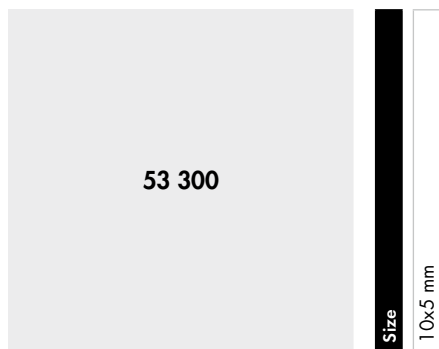

- Crystal**
- Crystal (001)
- Colors**
- Plain Colors**
- Amethyst (204)
- Black Diamond (215)
- Emerald (205)
- Fuchsia (502)
- Jet (280)
- Light Amethyst (212)
- Light Colorado Topaz (246)
- Light Rose (223)
- Light Sapphire (211)
- Rose (209)
- Sapphire (206)
- Siam (208)
- Topaz (203)



- Crystal Effects**
- Transparent Effects**
- Crystal AB (001 AB)
- Crystal Golden Shadow (001 GSHA)
- Crystal Lilac Shadow (001 LISH)
- Crystal Silver Shade (001 SSHA)

55 500 Oval

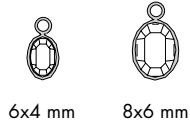
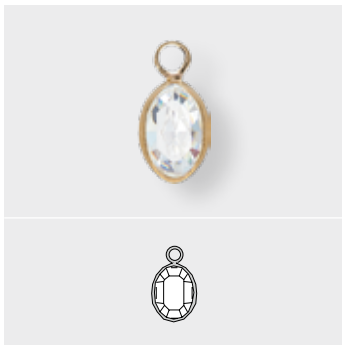

Stone Size		Ring Configuration		Back Configuration		Stone Art. No.
Code	Description	Code	Description	Code	Description	
06M	6x4 mm	1T	1R, Top	O	Open	4128
06M	6x4 mm	TB	2R, Top/Bottom	O	Open	
08M	8x6 mm	1T	1R, Top	O	Open	
08M	8x6 mm	TB	2R, Top/Bottom	O	Open	

Ring Configuration		Back Configuration	
1T	TB	Open	

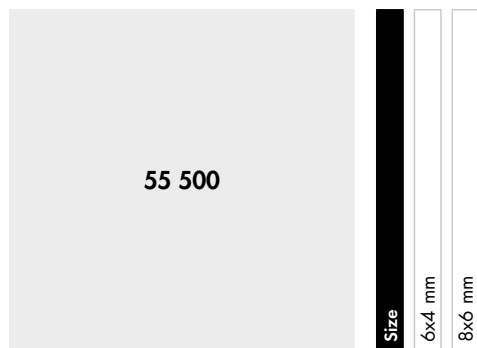

Crystal	
Crystal (001)	
Colors	
Plain Colors	
Amethyst (204)	
Black Diamond (215)	
Emerald (205)	
Fuchsia (502)	
Jet (280)	
Light Amethyst (212)	
Light Rose (223)	
Light Sapphire (211)	
Rose (209)	
Sapphire (206)	
Siam (208)	
Topaz (203)	

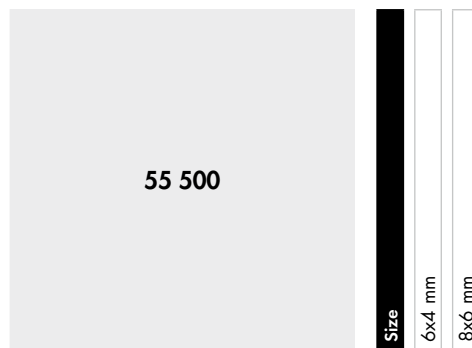

Crystal Effects	
Transparent Effects	
Crystal Golden Shadow (001 GSHA)	

57 700 Round

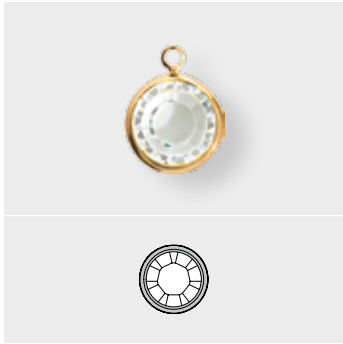

SS 29

Stone Size		Ring Configuration		Back Configuration		Stone Art. No.
Code	Description	Code	Description	Code	Description	
S29	SS 29	1T	1R, Top	O	Open	1128
S29	SS 29	TB	2R, Top/Bottom	O	Open	

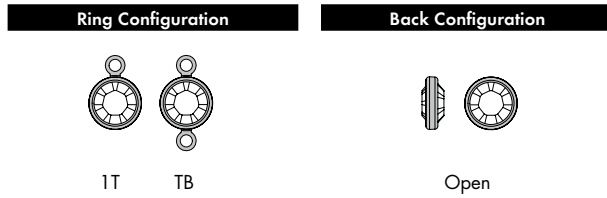

57 700

Size SS 29

- Crystal**
- Crystal (001)
- Colors**
- Plain Colors**
- Amethyst (204)
- Black Diamond (215)
- Emerald (205)
- Jet (280)
- Light Amethyst (212)
- Light Colorado Topaz (246)
- Light Rose (223)
- Light Sapphire (211)
- Rose (209)
- Sapphire (206)
- Siam (208)
- Topaz (203)

57 700

Size SS 29

- Crystal Effects**
- Transparent Effects**
- Crystal Golden Shadow (001 GSHA)

Stock Program

57 700

Size S29 1T O

- Color/Plating**
- Crystal Z (001)
- Crystal H (001)
- Crystal 3 (001)

METAL BUTTONS

These products are Round and Fancy Stones that are combined with metal components to form the shape of a button.

ORDERING EXAMPLE & PRODUCT VARIETY EXPLANATION

60 408 Metal Button

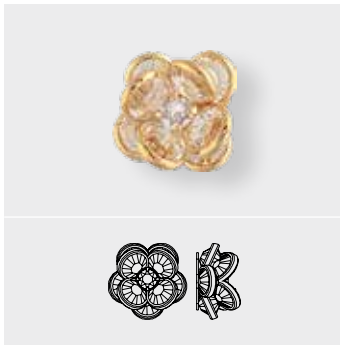

1	60 408	S29	00	C
Material type	Base item number	Stone size	Ring configuration	Back configuration
1 Brass	Number above product picture 60 Metal Buttons 61 Metal Buttons	3-digit code from respective product matrix	00 None	C Closed
F1	A	1088	F	001 229
Stone pattern	Plating	Base item art. no.	Foiling	Color of crystal
F1 Crystal/color/effect	Can be added at an additional charge. Z No Plating G Gun Metal* 3 Gold* H Rhodium* R Rose Gold*	1088 1128	F Foiled	Please see the respective color chart at the beginning of this chapter for all available code references. The articles are built from bottom up and outside in.
	* Anti nickel allergenic			

Not all configurations are available for all articles. Please refer to the respective product matrix for available combinations.

60 408 Metal Button

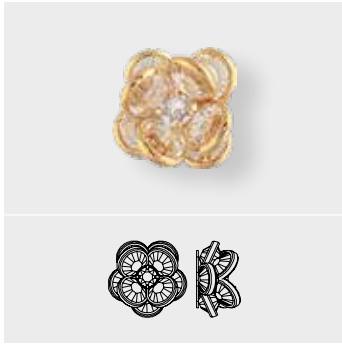

Stone Size		Ring Configuration		Back Configuration		Stone Art. No.		
Code	Description	Code	Description	Code	Description	1128	1128	1088
S29	SS 29, SS 29, PP 32	00	None	C	Closed			

60 408

Size

SS 29

PP 32

Crystal

- Crystal F (001)

Colors

Plain Colors

- Amethyst F (204)
- Black Diamond F (215)
- Emerald F (205)
- Fuchsia F (502)
- Jet F (280)
- Light Amethyst F (212)
- Light Colorado Topaz F (246)
- Light Sapphire F (211)
- Light Rose F (223)
- Rose F (209)
- Sapphire F (206)
- Siam F (208)
- Smoky Quartz F (225)
- Topaz F (203)

Crystal Effects

Transparent Effects

- Crystal AB F (001 AB)
- Crystal Golden Shadow F (001 GSHA)
- Crystal Lilac Shadow F (001 LISH)
- Crystal Silver Shade F (001 SSHA)

Stock Program

60 408

Size

S29 00 C

Color/Plating

- Crystal 3 (001)
- Crystal H (001)
- Crystal AB H (001 AB)
- Light Rose H (223)

60 444 Metal Button

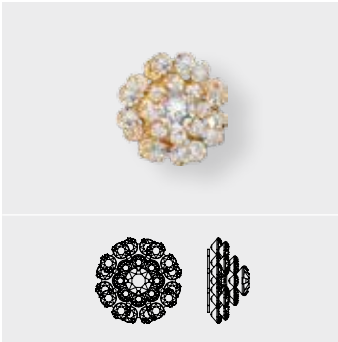

Stone Size		Ring Configuration		Back Configuration		Stone Art. No.			
Code	Description	Code	Description	Code	Description				
P24	PP 24, PP 24, PP 18, SS 24	00	None	C	Closed	1088	1088	1088	1088

60 444

Size	PP 24	PP 18	SS 24
Crystal			
Colors			
Plain Colors			
Crystal Effects			
Transparent Effects			

- Crystal F (001)
- Amethyst F (204)
- Black Diamond F (215)
- Emerald F (205)
- Fuchsia F (502)
- Jet F (280)
- Light Amethyst F (212)
- Light Colorado Topaz F (246)
- Light Rose F (223)
- Light Sapphire F (211)
- Rose F (209)
- Sapphire F (206)
- Siam F (208)
- Smoky Quartz F (225)
- Topaz F (203)
- Crystal AB F (001 AB)
- Crystal Golden Shadow F (001 GSHA)
- Crystal Lilac Shadow F (001 LISH)
- Crystal Silver Shade F (001 SSHA)

61 019 Metal Button

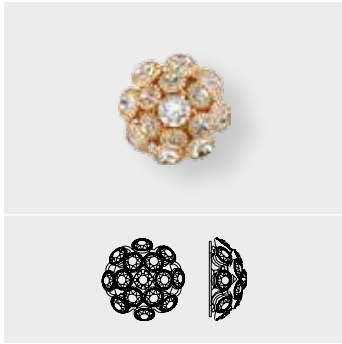

Stone Size		Ring Configuration		Back Configuration		Stone Art. No.		
Code	Description	Code	Description	Code	Description			
P32	PP 32, PP 32, PP 24	00	None	C	Closed	1088	1088	1088

61 019

Size

PP 24

PP 32

61 019

Size

P32 00 C

Color/Plating

Crystal H (001)

- Crystal**
- Crystal F (001)
- Colors**
- Plain Colors**
- Amethyst F (204)
- Black Diamond F (215)
- Emerald F (205)
- Fuchsia F (502)
- Jet F (280)
- Light Amethyst F (212)
- Light Colorado Topaz F (246)
- Light Rose F (223)
- Light Sapphire F (211)
- Rose F (209)
- Sapphire F (206)
- Siam F (208)
- Smoky Quartz F (225)
- Topaz F (203)
- Crystal Effects**
- Transparent Effects**
- Crystal AB F (001 AB)
- Crystal Golden Shadow F (001 GSHA)
- Crystal Lilac Shadow F (001 LISH)
- Crystal Silver Shade F (001 SSHA)

RONDELLES

Rondelles are Round and Fancy Stones with metal parts that can be used as a spacer between Beads or Crystal Pearls.

ARTICLE EXPLANATION - BASE ITEM NUMBER

77 503 - 77 510 Rondelle Spacer

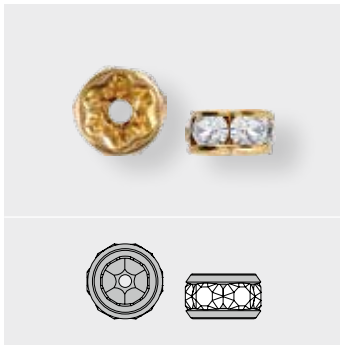

7	7	5	04
Product category	Stone code (type of stone used)	Setting code	Outer diameter (always 2-digit code)
7 Rondelles	7 Rondelle	5 Spacer 6 Square 7 Bar 8 XILION Square	03 04 05 06 07 08 09 10 12 19 25 30

ORDERING EXAMPLE & PRODUCT VARIETY EXPLANATION

1	77 504	P13	00	0
Stone pattern	Base item number	Stone size	Ring configuration	Back configuration
F1 Crystal/color/ effect		3-digit code from respective product matrix	00 None	0 None H Hole
F1	S	1088	F	215
Stone pattern	Plating	Base item art. no.	Foiling	Color of crystal
F1 Crystal/color/ effect	Can be added at an additional charge.	1088 4428	F Foiled	Please see the respective color chart at the beginning of this chapter for all available code references.
	Z No Plating G Gun Metal* 3 Gold* H Rhodium* R Rose Gold*			

* Anti nickel allergenic

Not all configurations are available for all articles. Please refer to the respective product matrix for available combinations.

77 503 – 77 510 Rondelle Spacer

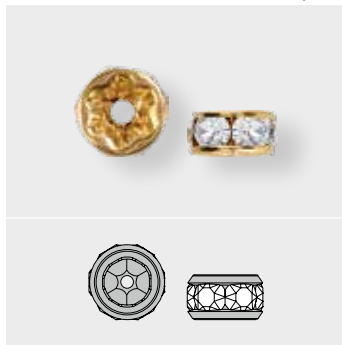

Base Item No.	Stone Size		Ring Configuration		Back Configuration		Stone Art.No.	
	Code	Description	Code	Description	Code	Description		
77 503	P11	PP 11	00	None	0	None	1028	1088
77 504	P13	PP 13	00	None	0	None		
77 505	P16	PP 16	00	None	0	None		
77 506	P20	PP 20	00	None	0	None		
77 506	P24	PP 24	00	None	0	None		
77 507	P24	PP 24	00	None	0	None		
77 508	P24	PP 24	00	None	0	None		
77 509	P24	PP 24	00	None	0	None		
77 510	P25	PP 25	00	None	0	None		

Cupchains & Findings

Rondelles

77 503 - 77 510		Size	PP 11	PP 13	PP 16	PP 20	PP 24	PP 25
Crystal								
Crystal F (001)			■	■	■	■	■	■
Colors								
Plain Colors								
Amethyst F (204)			■	■	■	■	■	■
Aquamarine F (202)			■	■	■	■	■	■
Black Diamond F (215)			■	■	■	■	■	■
Emerald F (205)			■	■	■	■	■	■
Jet (280)			■	■	■	■	■	■
Jonquil F (213)			■	■	■	■	■	■
Light Amethyst F (212)			■	■	■	■	■	■
Light Colorado Topaz F (246)			■	■	■	■	■	■
Light Rose F (223)			■	■	■	■	■	■
Light Sapphire F (211)			■	■	■	■	■	■
Light Siam F (227)			■	■	■	■	■	■
Montana F (207)			■	■		■		
Peridot F (214)			■	■	■	■	■	■
Rose F (209)			■	■	■	■	■	■
Sapphire F (206)			■	■	■	■	■	■
Siam F (208)			■	■	■	■	■	■
Smoked Topaz F (220)			■	■	■	■	■	■
Tanzanite F (539)			■	■	■	■	■	■
Topaz F (203)			■	■	■	■	■	■
Crystal Effects								
Transparent Effects								
Crystal AB F (001 AB)			■	■	■	■	■	■
Crystal Golden Shadow F (001 GSHA)			■	■		■		
Crystal Lilac Shadow F (001 LISH)			■	■		■		
Crystal Silver Shade F (001 SSHA)			■	■		■		

Stock Program

77 503		Size	P11
Color/Plating			
Crystal Z (001)			■
Crystal 3 (001)			■
Crystal H (001)			■

Stock Program

77 504		Size	P13
Color/Plating			
Crystal Z (001)			■
Crystal 3 (001)			■
Crystal H (001)			■
Crystal AB 3 (001 AB)			■
Crystal AB H (001 AB)			■
Jet H (280)			■

Cupchains & Findings

Rondelles

Stock Program

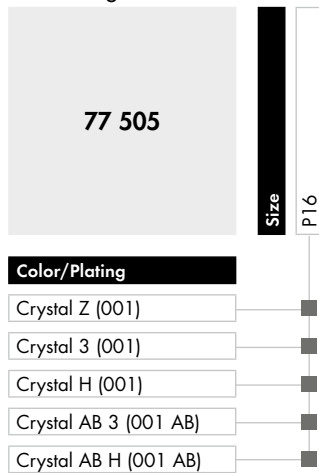

Stock Program

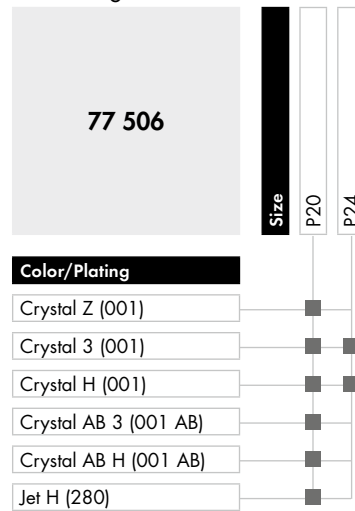

Stock Program

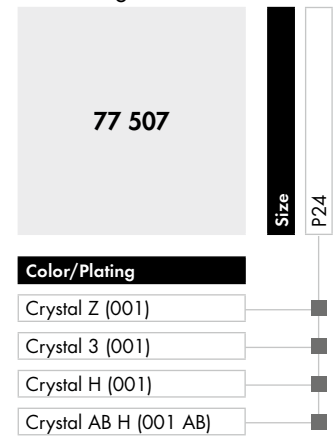

Stock Program

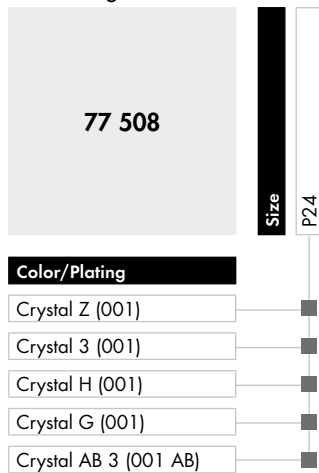

Stock Program

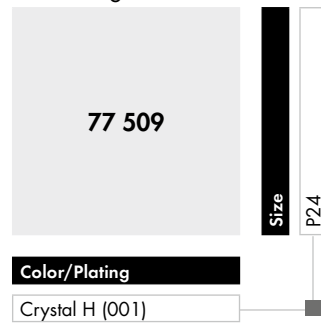

Stock Program

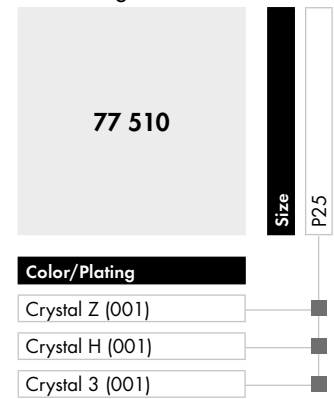

77 510 & 77 512 BeCharmed Rondelle

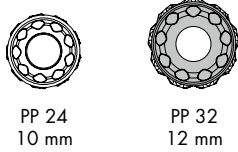

Base Item No.	Stone Size		Ring Configuration		Back Configuration		Stone Art.No.
	Code	Description	Code	Description	Code	Description	
77 510	P24	PP 24	00	None	H	Hole	1088
77 512	P32	PP 32	00	None	H	None	

77 510 & 77 512

Size: PP 24, PP 32

Crystal

Crystal F (001)

Colors

Plain Colors

- Amethyst F (204)
- Aquamarine F (202)
- Black Diamond F (215)
- Emerald F (205)
- Jet (280)
- Jonquil F (213)
- Light Amethyst F (212)
- Light Colorado Topaz F (246)
- Light Rose F (223)
- Light Sapphire F (211)
- Light Siam F (227)
- Montana F (207)
- Peridot F (214)
- Rose F (209)
- Sapphire F (206)
- Siam F (208)
- Smoked Topaz F (220)
- Tanzanite F (539)
- Topaz F (203)

77 510 & 77 512

Size: PP 24, PP 32

Crystal Effects

Transparent Effects

- Crystal AB F (001 AB)
- Crystal Golden Shadow F (001 GSHA)
- Crystal Lilac Shadow F (001 LISH)
- Crystal Silver Shade F (001 SSHA)

Stock Program

77 510

Size: P24

Color/Plating

- Crystal Z (001)
- Crystal H (001)
- Crystal 3 (001)

Stock Program

77 512

Size: P32

Color/Plating

- Crystal Z (001)
- Crystal H (001)
- Crystal 3 (001)

77 604 – 77 608 Rondelle Square

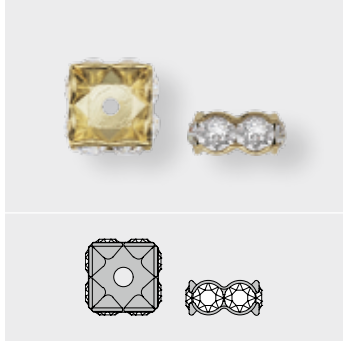

PP 13
4 mm



PP 18
6 mm



PP 24
8 mm

Base Item No.	Stone Size		Ring Configuration		Back Configuration		Stone Art.No.	
	Code	Description	Code	Description	Code	Description		
77 604	P13	PP 13	00	None	0	None	1028	1088
77 606	P18	PP 18	00	None	0	None		
77 608	P24	PP 24	00	None	0	None		

77 604 – 77 608

Size

- PP 13 (4 mm)
- PP 18 (6 mm)
- PP 24 (8 mm)

- Crystal**
- Crystal F (001)
- Colors**
- Plain Colors**
- Amethyst F (204)
 - Aquamarine F (202)
 - Black Diamond F (215)
 - Emerald F (205)
 - Jet (280)
 - Jonquil F (213)
 - Light Amethyst F (212)
 - Light Colorado Topaz F (246)
 - Light Rose F (223)
 - Light Sapphire F (211)
 - Light Siam F (227)
 - Montana F (207)
 - Peridot F (214)
 - Rose F (209)
 - Sapphire F (206)
 - Siam F (208)
 - Smoked Topaz F (220)
 - Tanzanite F (539)
 - Topaz F (203)

77 604 – 77 608

Size

- PP 13 (4 mm)
- PP 18 (6 mm)
- PP 24 (8 mm)

- Crystal Effects**
- Transparent Effects**
- Crystal AB F (001 AB)
 - Crystal Golden Shadow F (001 GSHA)
 - Crystal Lilac Shadow F (001 LISH)
 - Crystal Silver Shade F (001 SSHA)

Cupchains & Findings

Rondelles

Stock Program

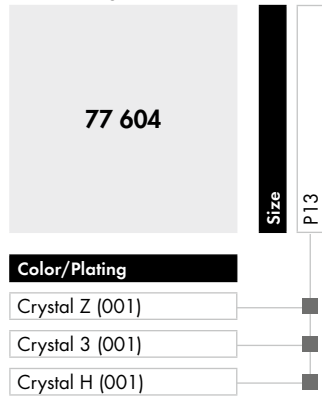

Stock Program

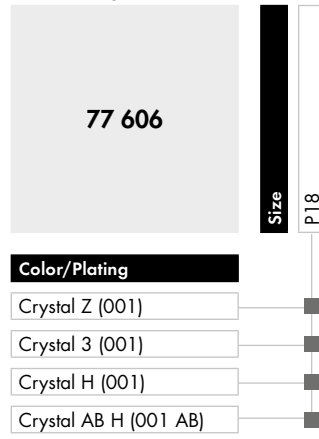

Stock Program

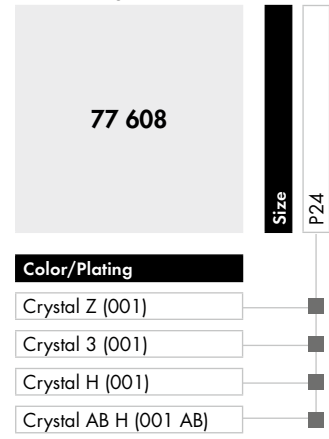

77 710 – 77 730 Rondelle Bar

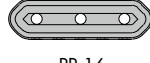
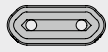
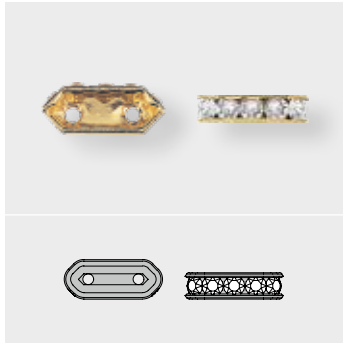

PP 16
10x5 mm

PP 16
19x5 mm

PP 18
25x5 mm

PP 18
30x5 mm

Base Item No.	Stone Size		Ring Configuration		Back Configuration		Stone Art.No.
	Code	Description	Code	Description	Code	Description	
77 710	P16	PP 16	00	None	0	None	1088
77 719	P16	PP 16	00	None	0	None	
77 725	P18	PP 18	00	None	0	None	
77 730	P18	PP 18	00	None	0	None	

77 710 – 77 730

Size

PP 16

PP 18

- Crystal**
- Crystal F (001)
- Colors**
- Plain Colors**
- Amethyst F (204)
- Aquamarine F (202)
- Black Diamond F (215)
- Emerald F (205)
- Jet (280)
- Jonquil F (213)
- Light Amethyst F (212)
- Light Colorado Topaz F (246)
- Light Rose F (223)
- Light Sapphire F (211)
- Light Siam F (227)
- Montana F (207)
- Peridot F (214)
- Rose F (209)
- Sapphire F (206)
- Siam F (208)

77 710 – 77 730

Size

PP 16

PP 18

- Smoked Topaz F (220)
- Tanzanite F (539)
- Topaz F (203)
- Crystal Effects**
- Transparent Effects**
- Crystal AB F (001 AB)
- Crystal Golden Shadow F (001 GSHA)
- Crystal Lilac Shadow F (001 LISH)
- Crystal Silver Shade F (001 SSHA)

Cupchains & Findings

Rondelles

Stock Program

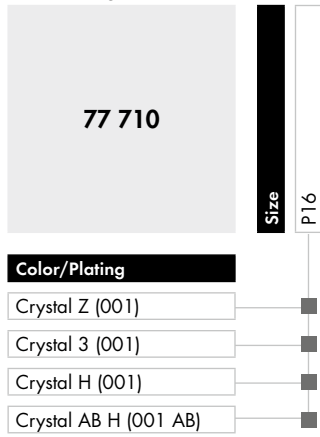

Stock Program

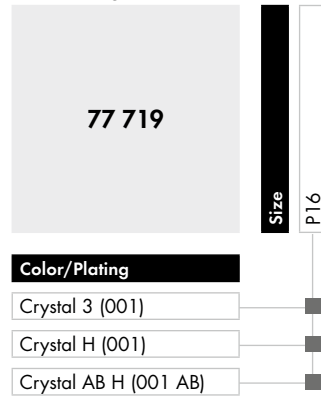

Stock Program

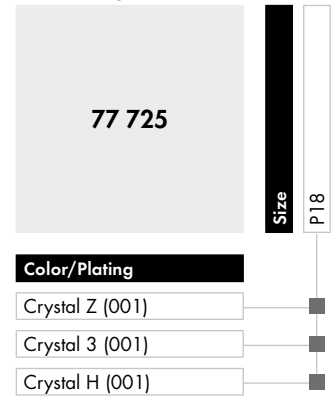

Stock Program

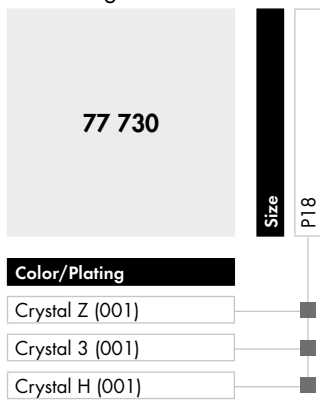

77 806 XILION Square Rondelle

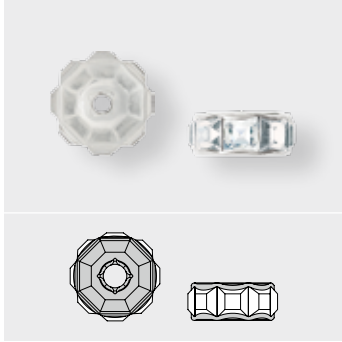

2 mm
6 mm

Base Item No.	Stone Size		Ring Configuration		Back Configuration		Stone Art.No.	Outside Diameter
	Code	Description	Code	Description	Code	Description		
77 806	02M	2 mm	00	None	0	None	4428	6 mm

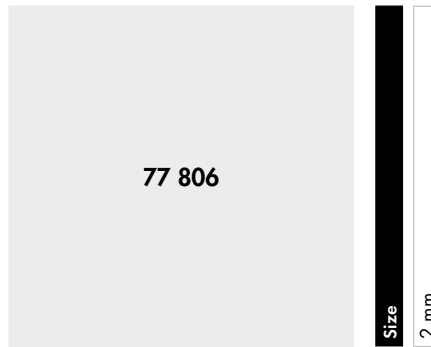
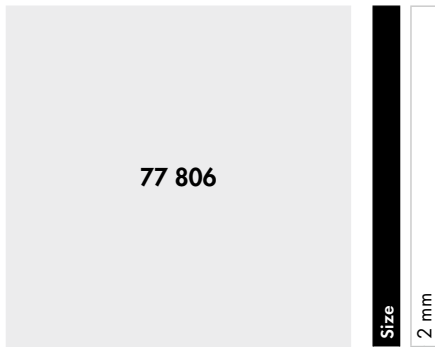

- Crystal**
- Crystal F (001)
- Colors**
- Plain Colors**
- Amethyst F (204)
 - Aquamarine F (202)
 - Black Diamond F (215)
 - Emerald F (205)
 - Jet (280)
 - Light Amethyst F (212)
 - Light Colorado Topaz F (246)
 - Light Rose F (223)
 - Light Sapphire F (211)
 - Light Siam F (227)
 - Montana F (207)
 - Peridot F (214)
 - Rose F (209)
 - Sapphire F (206)
 - Siam F (208)
 - Smoked Topaz F (220)
 - Tanzanite F (539)
 - Topaz F (203)

- Crystal Effects**
- Transparent Effects**
- Crystal AB F (001 AB)
 - Crystal Golden Shadow F (001 GSHA)
 - Crystal Lilac Shadow F (001 LISH)
 - Crystal Silver Shade F (001 SSHA)

PRODUCT DETAILS

Article	Stone Article Number	Stone Size	Number of Stones	Outside Diameter
77 503				
1028		PP 11	5	3 mm
77 504				
1028		PP 13	6	4 mm
77 505				
1088		PP 16	6	5 mm
77 506				
1088		PP 20	6	6 mm
1088		PP 24	5	6 mm
77 507				
1088		PP 24	6	7 mm
77 508				
1088		PP 24	7	8 mm
77 509				
1088		PP 24	8	9 mm
77 510				
1088		PP 25	9	10 mm
77 510				
1088		PP 24	9	10 mm
77 512				
1088		PP 32	9	12 mm
77 604				
1028		PP 13	8	4 mm
77 606				
1088		PP 18	8	6 mm
77 608				
1088		PP 24	8	8 mm
77 710				
1088		PP 16	5	10x5 mm
77 719				
1088		PP 16	8	19x5 mm
77 725				
1088		PP 18	10	25x5 mm
77 730				
1088		PP 18	12	30x5 mm
77 806				
4428		2 mm	8	6 mm

LINKED FINDINGS

Linked Findings incorporate Channels and Bead Chains, and the Crystal and Channel Web. The Crystal and Channel Webs are combinations of loose crystals with metal elements, which can be ordered in sheets or by the meter.

ORDERING EXAMPLE & PRODUCT VARIETY EXPLANATION

90 022 Bead



1	90 022	06M	00	0
Stone pattern	Base item number	Stone size	Ring configuration	Back configuration
F1 Crystal/color/effect	Number above product picture always starting with 90	3-digit code from respective product matrix	00 None	0 None
F1	G	5000	203	
Stone pattern	Plating	Base item art. no.	Color of crystal	
F1 Crystal/color/effect	Can be added at an additional charge. Z No Plating G Gun Metal* 3 Gold* H Rhodium* R Rose Gold*	1122	Please see the respective color chart at the beginning of this chapter for all available code references.	
F2 2 alternate colors		1128		
F3 3 alternate colors		4228		
F4 4 alternate colors		5000		

* Anti nickel allergenic

Not all configurations are available for all articles. Please refer to the respective product matrix for available combinations.

90 005 Round

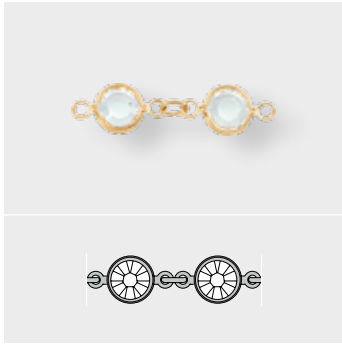

Stone Size		Ring Configuration		Back Configuration		Stone Art. No.	
Code	Description	Code	Description	Code	Description		
S29	SS 29	00	None	O	Open	1122	1128

90 005

Size

SS 29 (1122)

SS 29 (1128)

- Crystal**
 - Crystal (001)
- Colors**
- Plain Colors**
 - Amethyst (204)
 - Aquamarine (202)
 - Black Diamond (215)
 - Emerald (205)
 - Fuchsia (502)
 - Jet (280)
 - Jonquil (213)
 - Light Amethyst (212)
 - Light Colorado Topaz (246)
 - Light Rose (223)
 - Light Sapphire (211)
 - Peridot (214)
 - Rose (209)
 - Sapphire (206)
 - Siam (208)
 - Topaz (203)
 - Dark Multi (902)*
 - Light Multi (907)**

90 005

Size

SS 29 (1122)

SS 29 (1128)

- Crystal Effects**
- Transparent Effects**
 - Crystal AB (001 AB)
 - Crystal Golden Shadow (001 GSHA)
 - Crystal Silver Shade (001 SSHA)

Stock Program

90 005

Size

S29 00 O

- Color/Plating**
 - Crystal H (001)
 - Crystal 3 (001)
 - Light Multi H (907)
 - Light Multi 3 (907)

* Dark Multi consists of Topaz, Sapphire, Emerald, Amethyst, Siam.
 **Light Multi consists of Jonquil, Light Amethyst, Light Sapphire, Light Rose, Peridot.

90 009 Round

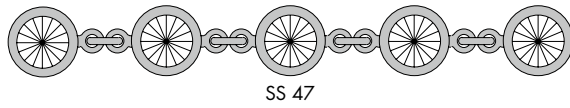

Stone Size		Ring Configuration		Back Configuration		Stone Art. No.
Code	Description	Code	Description	Code	Description	
S47	SS 47	00	None	O	Open	1122

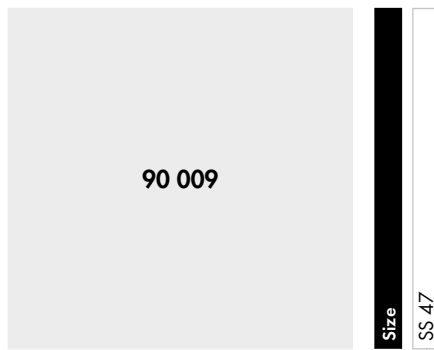
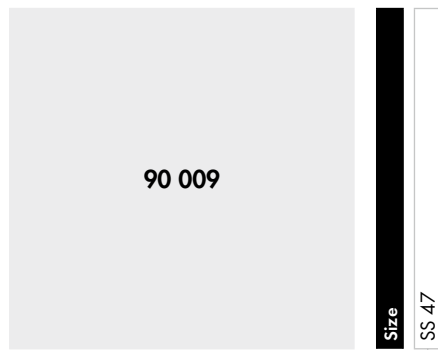

- Crystal**
 - Crystal (001)
- Colors**
- Plain Colors**
 - Amethyst (204)
 - Aquamarine (202)
 - Black Diamond (215)
 - Emerald (205)
 - Fuchsia (502)
 - Jet (280)
 - Light Amethyst (212)
 - Light Colorado Topaz (246)
 - Light Rose (223)
 - Light Sapphire (211)
 - Peridot (214)
 - Rose (209)
 - Sapphire (206)
 - Siam (208)
 - Topaz (203)
 - Dark Multi (902)*

- Crystal Effects**
- Transparent Effects**
 - Crystal AB (001 AB)
 - Crystal Golden Shadow (001 GSHA)
 - Crystal Lilac Shadow (001 LISH)
 - Crystal Silver Shade (001 SSHA)

* Dark Multi consists of Topaz, Sapphire, Emerald, Amethyst, Siam.

90 014 Navette

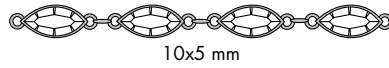
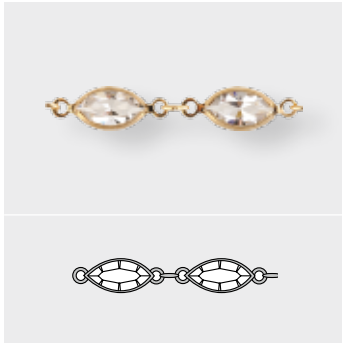

Stone Size		Ring Configuration		Back Configuration		Stone Art. No.
Code	Description	Code	Description	Code	Description	
10M	10x5 mm	00	None	O	Open	4228



90 014



Size
10x5 mm

- Crystal**
- Crystal (001)
- Colors**
- Plain Colors**
- Amethyst (204)
- Aquamarine (202)
- Black Diamond (215)
- Emerald (205)
- Fuchsia (502)
- Jet (280)
- Jonquil (213)
- Light Amethyst (212)
- Light Colorado Topaz (246)
- Light Rose (223)
- Light Sapphire (211)
- Peridot (214)
- Rose (209)
- Sapphire (206)
- Siam (208)
- Topaz (203)
- Dark Multi (902)*
- Light Multi (907)**

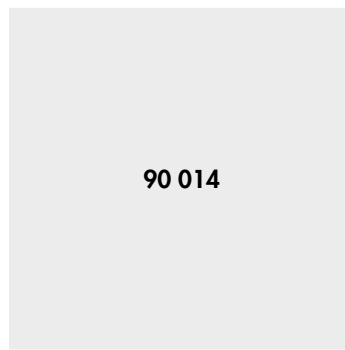

90 014



Size
10x5 mm

- Crystal Effects**
- Transparent Effects**
- Crystal AB (001 AB)
- Crystal Golden Shadow (001 GSHA)
- Crystal Lilac Shadow (001 LISH)
- Crystal Moonlight (001 MOL)
- Crystal Silver Shade (001 SSHA)

* Dark Multi consists of Topaz, Sapphire, Emerald, Amethyst, Siam.

**Light Multi consists of Jonquil, Light Amethyst, Light Sapphire, Light Rose, Peridot.

90 022 Bead

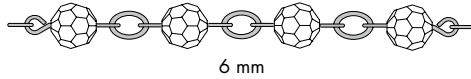
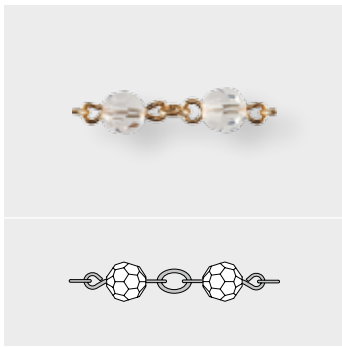

Stone Size		Ring Configuration		Back Configuration		Stone Art. No.
Code	Description	Code	Description	Code	Description	
06M	6 mm	00	None	O	Open	5000

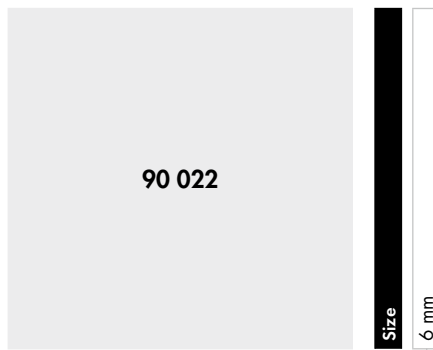

- Crystal**
 - Crystal (001)
- Colors**
- Plain Colors**
 - Amethyst (204)
 - Aquamarine (202)
 - Black Diamond (215)
 - Emerald (205)
 - Fuchsia (502)
 - Jet (280)
 - Jonquil (213)
 - Light Amethyst (212)
 - Light Colorado Topaz (246)
 - Light Rose (223)
 - Light Sapphire (211)
 - Peridot (214)
 - Rose (209)
 - Sapphire (206)
 - Siam (208)
 - Topaz (203)
 - Dark Multi (902)*
 - Light Multi (907)**

- Crystal Effects**
- Transparent Effects**
 - Crystal AB (001 AB)
 - Crystal Golden Shadow (001 GSHA)
 - Crystal Lilac Shadow (001 LISH)
 - Crystal Moonlight (001 MOL)
 - Crystal Silver Shade (001 SSHA)

* Dark Multi consists of Topaz, Sapphire, Emerald, Amethyst, Siam.

**Light Multi consists of Jonquil, Light Amethyst, Light Sapphire, Light Rose, Peridot.

ORDERING EXAMPLE & PRODUCT VARIETY EXPLANATION

98 001

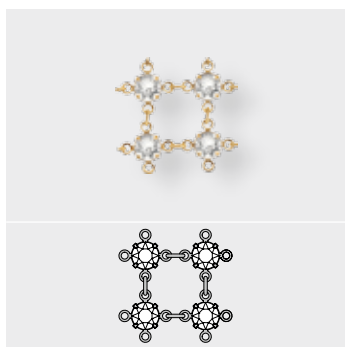

1	98 001	S29	01	N
Stone pattern	Base item number	Stone size	Ring configuration	Back configuration >>
F1 Crystal/color/ effect	Number above product picture always starting with 98	3-digit code from respective product matrix	01 Sheet	R Rings outside
>> F1	G	1088	F	501
Stone pattern	Plating	Base item art. no.	Foiling	Color of crystal
F1 Crystal/color/ effect	Can be added at an additional charge. Z No Plating G Gun Metal* 3 Gold* H Rhodium* R Rose Gold*	1088 1128	F Foiled Unfoiled	Please see the respective color chart at the beginning of this chapter for all available code references.

* Anti nickel allergenic

98 001

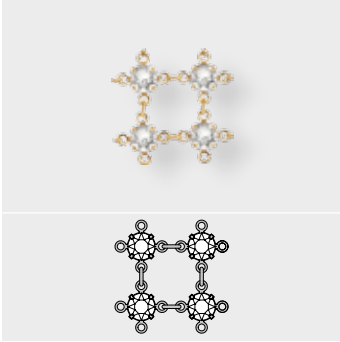

Stone Size		Ring Configuration		Back Configuration		Sheet Size	Stone Art. No.
Code	Description	Code	Description	Code	Description	Description	
S29	SS 29	01	Sheet	R	Rings outside	~500x200 mm	1088

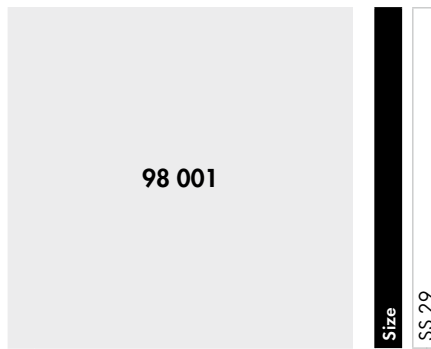
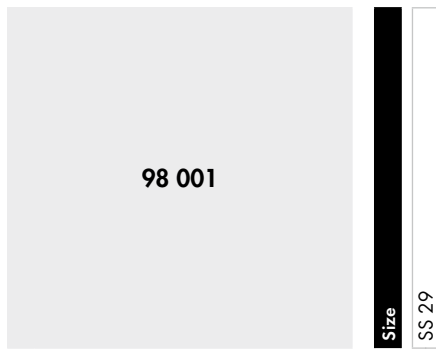
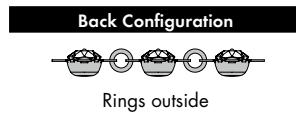

- Crystal**
- Crystal F (001)
- Colors**
- Plain Colors**
- Amethyst F (204)
 - Aquamarine F (202)
 - Black Diamond F (215)
 - Emerald F (205)
 - Fuchsia F (502)
 - Jet F (280)
 - Jonquil F (213)
 - Light Amethyst F (212)
 - Light Colorado Topaz F (246)
 - Light Rose F (223)
 - Light Sapphire F (211)
 - Peridot F (214)
 - Rose F (209)
 - Sapphire F (206)
 - Siam F (208)
 - Topaz F (203)

- Dark Multi F (902)*
 - Light Multi F (907)**
- Crystal Effects**
- Transparent Effects**
- Crystal AB F (001 AB)
 - Crystal Golden Shadow F (001 GSHA)
 - Crystal Lilac Shadow F (001 LISH)
 - Crystal Moonlight F (001 MOL)
 - Crystal Silver Shade F (001 SSHA)

Stock Program

Color/Plating

- Crystal Z (001)

* Dark Multi F consists of Topaz, Sapphire, Emerald, Amethyst, Siam.
 **Light Multi F consists of Jonquil, Light Amethyst, Light Sapphire, Light Rose, Peridot.

98 002 Channel Web Sheet

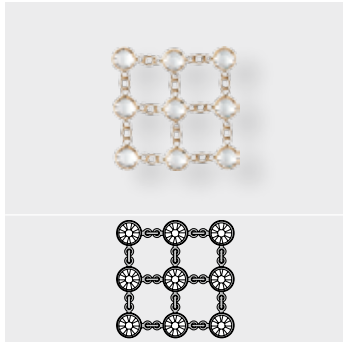

Stone Size		Ring Configuration		Back Configuration		Sheet Size	Stone Art. No.
Code	Description	Code	Description	Code	Description	Description	
S29	SS 29	01	Sheet	R	Rings outside	~500x200 mm	1128

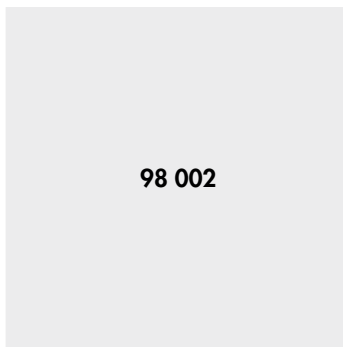
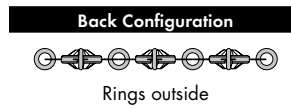

Size
SS 29

- Crystal**
- Crystal (001)
- Colors**
- Plain Colors**
- Amethyst (204)
- Aquamarine (202)
- Black Diamond (215)
- Emerald (205)
- Jet (280)
- Jonquil (213)
- Light Amethyst (212)
- Light Colorado Topaz (246)
- Light Rose (223)
- Light Sapphire (211)
- Peridot (214)
- Rose (209)
- Sapphire (206)
- Siam (208)
- Topaz (203)
- Dark Multi (902)*
- Light Multi (907)**

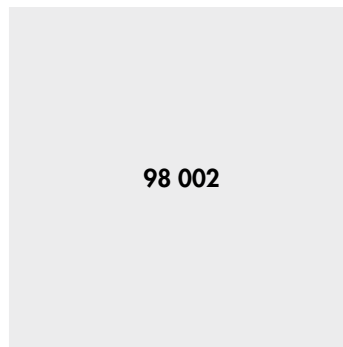

Size
SS 29

- Crystal Effects**
- Transparent Effects**
- Crystal Golden Shadow (001 GSHA)

* Dark Multi consists of Topaz, Sapphire, Emerald, Amethyst, Siam.
 **Light Multi consists of Jonquil, Light Amethyst, Light Sapphire, Light Rose, Peridot.

ORDERING EXAMPLE & PRODUCT VARIETY EXPLANATION

99 001

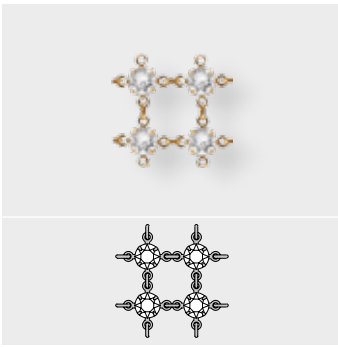

1	99 001	S29	03	R
Stone pattern	Base item number	Stone size	Ring configuration	Back configuration
F1 Crystal/color/ effect	Number above product picture always starting with 99	3-digit code from respective product matrix	02-15 Number of rows	R Rings outside
F1	3	1088	F	001
Stone pattern	Plating	Base item art. no.	Foiling	Color of crystal
F1 Crystal/color/ effect	Can be added at an additional charge. Z No Plating G Gun Metal* 3 Gold* H Rhodium* R Rose Gold*	1128 1088	F Foiled Unfoiled	Please see the respective color chart at the beginning of this chapter for all available code references.

* Anti nickel allergenic

Not all configurations are available for all articles. Please refer to the respective product matrix for available combinations.

99 001

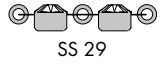
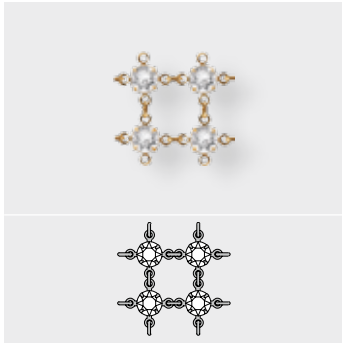

Stone Size		Ring Configuration		Back Configuration		Length	Stone Art. No.
Code	Description	Code	Description	Code	Description	Description	
S29	SS 29	02-15	Number of rows	R	Rings outside	1 row = 1 meter	1088

Back Configuration

Rings outside

99 001

Size SS 29

- Crystal**
- Crystal F (001)
- Colors**
- Plain Colors**
- Amethyst F (204)
- Aquamarine F (202)
- Black Diamond F (215)
- Emerald F (205)
- Fuchsia F (502)
- Jet F (280)
- Jonquil F (213)
- Light Amethyst F (212)
- Light Colorado Topaz F (246)
- Light Rose F (223)
- Light Sapphire F (211)
- Peridot F (214)
- Rose F (209)
- Sapphire F (206)
- Siam F (208)
- Topaz F (203)

99 001

Size SS 29

- Dark Multi F (902)*
- Light Multi F (907)**
- Crystal Effects**
- Transparent Effects**
- Crystal AB F (001 AB)
- Crystal Golden Shadow F (001 GSHA)
- Crystal Lilac Shadow F (001 LISH)
- Crystal Moonlight F (001 MOL)
- Crystal Silver Shade F (001 SSHA)

* Dark Multi F consists of Topaz, Sapphire, Emerald, Amethyst, Siam.
 **Light Multi F consists of Jonquil, Light Amethyst, Light Sapphire, Light Rose, Peridot.

99 002 Channel Web Row

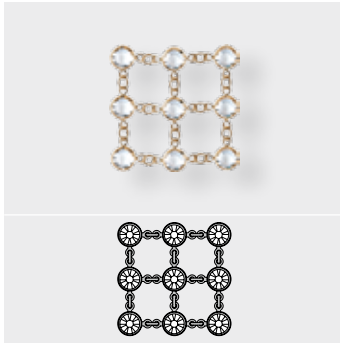

Stone Size		Ring Configuration		Back Configuration		Length	Stone Art. No.
Code	Description	Code	Description	Code	Description	Description	
S29	SS 29	02-15	Number of rows	R	Rings outside	1 row = 1 meter	1128

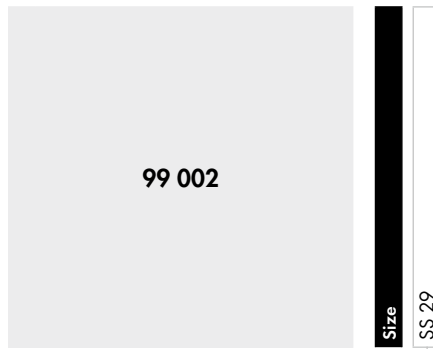
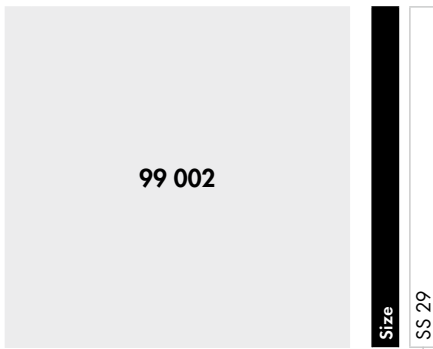
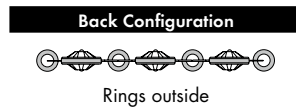

- Crystal**
 - Crystal (001)
- Colors**
- Plain Colors**
 - Amethyst (204)
 - Aquamarine (202)
 - Black Diamond (215)
 - Emerald (205)
 - Jet (280)
 - Jonquil (213)
 - Light Amethyst (212)
 - Light Colorado Topaz (246)
 - Light Rose (223)
 - Light Sapphire (211)
 - Peridot (214)
 - Rose (209)
 - Sapphire (206)
 - Siam (208)
 - Topaz (203)
 - Dark Multi (902)*
 - Light Multi (907)**

- Crystal Effects**
- Transparent Effects**
 - Crystal Golden Shadow (001 GSHA)

* Dark Multi consists of Topaz, Sapphire, Emerald, Amethyst, Siam.
 **Light Multi consists of Jonquil, Light Amethyst, Light Sapphire, Light Rose, Peridot.

PRODUCT DETAILS































Article Stone Article Number	Stone Size	Stones per meter	Stones per foot
90 005			
1122	SS 29	65	20
1128	SS 29	65	20
90 009			
1122	SS 47	51	16
90 014			
4228	10x5 mm	54	16
90 022			
5000	6 mm	71	25
99 001			
1088	SS 29	70	21
99 002			
1128	SS 29	66	20

Knobs, Handles & Co.

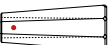
Knobs, Handles & Co. consist of loose crystals and forward-integrated products. They are ideal for use in the interior segment, for example for bathroom applications or furniture. The articles offered are divided into four categories: Centerparts, Balls, Lever Handles, and Forward-integrated Articles. All of these products come in a large variety of shapes and can be easily applied by gluing and/or screwing.

Knobs, Handles & Co

SUMMARY

1	2	3		1	2	3	
			7100 20, 30, 40, 50, 60 mm				7322 50 mm
			7110 30, 40, 50 mm				7323 48 mm
			7120 14, 20, 30, 40, 50 mm				
			7130 50 mm				
			7155 30 mm				
			7160 300 mm				
			7165 14 mm				
			7300 16 mm				
			7301 56 mm				
			7302 56 mm				
			7303 60 mm				
			7307 61 mm				
			7312 50 mm				

1 Top view/Threaded view 2 Side view/Hole view 3 Back view

• The logo position is marked with a red dot.

7100 Ball

Size
 20 mm
 30 mm
 40 mm
 50 mm
 60 mm

Crystal
 Crystal CAL VZ SI (001 CAL VZ SI)

7110 3/4 Ball

Size
 30 mm
 40 mm
 50 mm

Crystal
 Crystal CAL VZ SI (001 CAL VZ SI)

7120 Half Ball Classic Cut

Size
 14 mm
 20 mm
 30 mm
 40 mm
 50 mm

Crystal
 Crystal CAL (001 CAL SI)
 Crystal CAL V SI (001 CAL V SI)

Colors
Plain Colors
 Jet (280)

7130 Half Ball With Hole

Size
 50 mm

Crystal
 Crystal CAL V SI (001 CAL V SI)

• The logo position is marked with a red dot.

7155 Globe Handle



Size	300 mm
Color of Casing	081 Gold 082 Silver

Crystal

Crystal CAL VZ SI (001 CAL VZ SI)

7160 Tube Handle

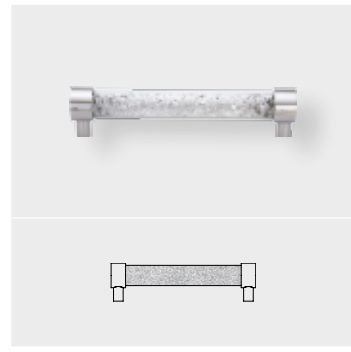

Size	300 mm
Color of Casing	081 Gold 082 Silver

Crystal

Crystal (001)

7165 Inlay



Size	14 mm
Color of Casing	082 Silver

Crystal

Crystal CAL V SI (001 CAL V SI)

• The logo position is marked with a red dot.

7300 Pin

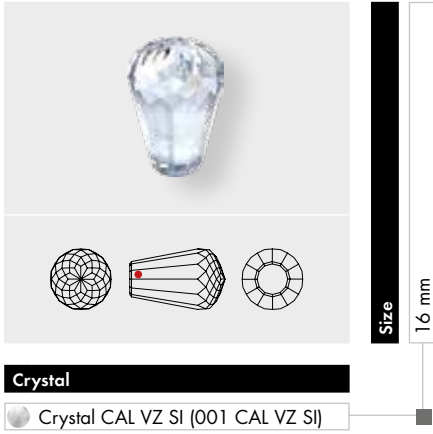

7301 Classic Lever Handle

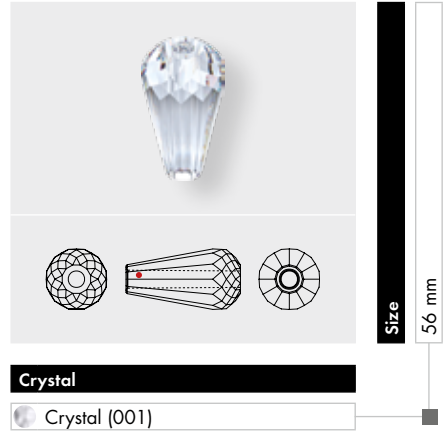

7302 Spiral

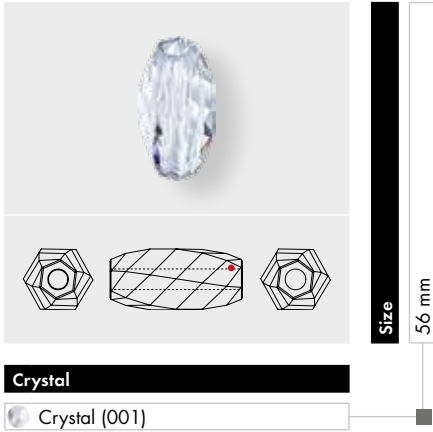

7303 Spectrum

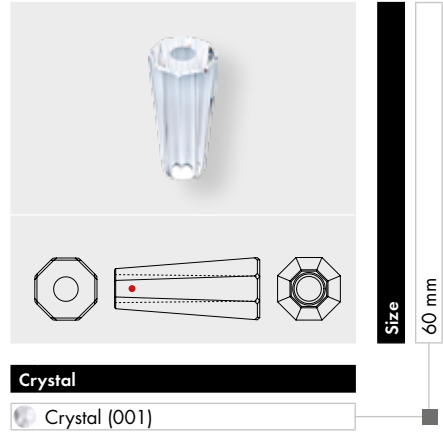

7307 Radiance Handle

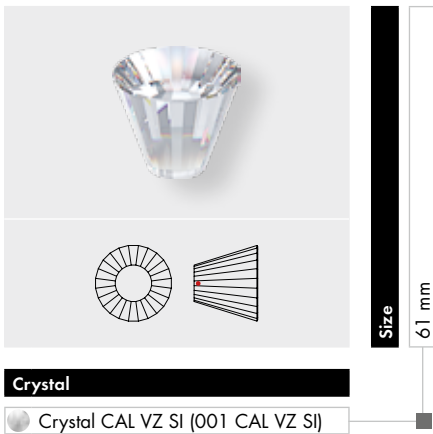

7312 Round Centerpart



7322 Ring Centerpart small hole

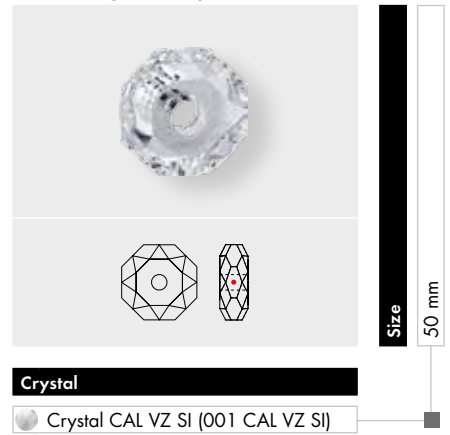

7323 Ring Centerpart big hole



• The logo position is marked with a red dot.

GLOBE HANDLE

single-sided assembly

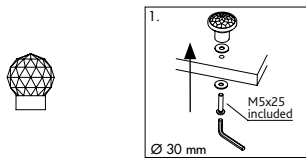

double-sided assembly

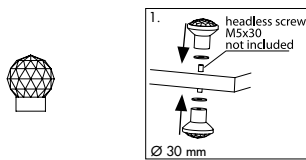

CRYSTAL TUBE HANDLE

single-sided assembly

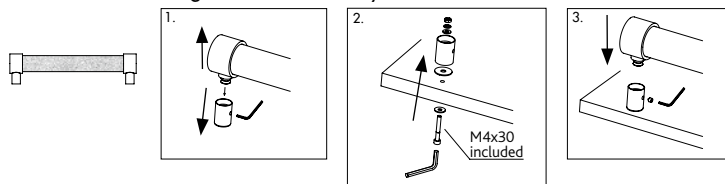

double-sided assembly

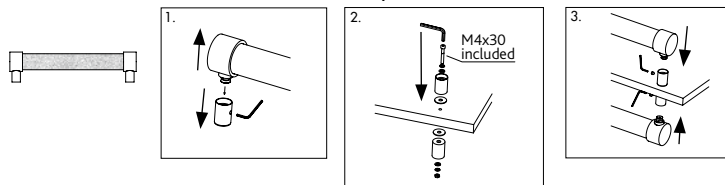

Sequence:

1. In the first step each mounting part is attached to the desired material (e.g. wood doors etc.).
2. Afterwards, Globe Handle/Tube Handle can be applied to the previously attached mounting parts using the supplied headless screw.

Note:

- For fragile materials, such as glass, mirrors etc., it is advisable to use the plastic washers provided.
- All enclosed mounting screws are designed for a wall thickness of a maximum of 16 mm.

CRYSTAL INLAYS

assembly

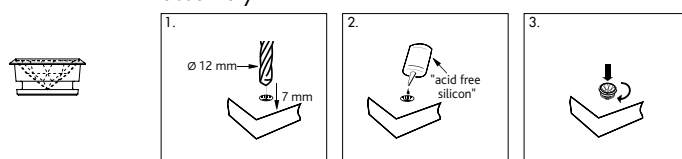

PRODUCT DETAILS

Article Size	Packing Unit = Minimum Order Quantity in Pieces	Average Net Weight in Gram per Packing Unit Crystal (001)	Average Gross Weight in Gram per Packing Unit Crystal (001)
7100			
20 mm	144	1,609.1	2,023.2
30 mm	48	1,774.3	2,281.5
40 mm	40	3,696.5	4,026.5
50 mm	12	1,954.9	2,236.9
60 mm	5	1,280.5	1,700.2
7110			
30 mm	48	1,521.9	1,876.8
40 mm	40	3,253.1	3,480.1
50 mm	12	1,924.3	2,254.6
7120			
14 mm	560	997.0	1,452.0
20 mm	300	1,615.1	2,057.1
30 mm	120	2,140.7	1,962.8
40 mm	60	2,669.0	3,111.0
50 mm	24	1,943.2	2,247.2
7130			
50 mm	24	1,711.3	1,997.3
7155			
30 mm	5	281.1	676.1
7160			
300 mm	1	950.0	1,050.0
7165			
14 mm	24	93.4	110.7
7300			
16 mm	192	1,627.8	2,001.8
7301			
56 mm	30	1,475.2	1,753.2
7302			
56 mm	45	2,447.8	2,684.8
7303			
60 mm	30	1,350.6	1,684.6
7307			
61 mm	5	1,189.5	1,471.5
7312			
50 mm	12	1,651.2	2,013.6
7322			
50 mm	36	2,951.4	3,150.3
7323			
48 mm	36	1,736.7	2,088.3

OPEN TO SEE SIZES

•	PP 1 (SS 000) 0.80–0.90 mm	●	PP 21 (SS 10) 2.70–2.80 mm	●	SS 25 5.44–5.61 mm	●	SS 45 9.85– 10.19 mm
•	PP 2 (SS 00) 0.90–1.00 mm	●	PP 22 (SS 10) 2.80–2.90 mm	●	SS 26 5.61–5.78 mm		
•	PP 3 (SS 0) 1.00–1.10 mm	●	PP 23 (SS 11) 2.90–3.00 mm	●	SS 27 5.78–5.96 mm	●	SS 46 10.19– 10.54 mm
•	PP 4 (SS 1) 1.10–1.20 mm	●	PP 24 (SS 12) 3.00–3.20 mm	●	SS 28 5.96–6.14 mm		
•	PP 5 (SS 2) 1.20–1.30 mm	●	PP 25 (SS 13) 3.20–3.30 mm	●	SS 29 6.14–6.32 mm	●	SS 47 10.54– 10.91 mm
•	PP 6 (SS 2) 1.30–1.35 mm	●	PP 26 (SS 13) 3.30–3.40 mm	●	SS 30 6.32–6.50 mm		
•	PP 7 (SS 3) 1.35–1.40 mm	●	PP 27 (SS 14) 3.40–3.50 mm	●	SS 31 6.50–6.68 mm	●	SS 48 10.91– 11.30 mm
•	PP 8 (SS 3) 1.40–1.50 mm	●	PP 28 (SS 14) 3.50–3.60 mm	●	SS 32 6.68–6.87 mm		
•	PP 9 (SS 4) 1.50–1.60 mm	●	PP 29 (SS 15) 3.60–3.70 mm	●	SS 33 6.87–7.07 mm	●	SS 49 11.30– 11.72 mm
•	PP 10 (SS 4) 1.60–1.70 mm	●	PP 30 (SS 15) 3.70–3.80 mm	●	SS 34 7.07–7.27 mm		
•	PP 11 (SS 5) 1.70–1.80 mm	●	PP 31 (SS 16) 3.80–4.00 mm	●	SS 35 7.27–7.48 mm	●	SS 50 11.72– 11.97 mm
•	PP 12 (SS 5) 1.80–1.90 mm	●	PP 32 (SS 17) 4.00–4.10 mm	●	SS 36 7.48–7.70 mm	●	SS 55 12.97– 13.22 mm
•	PP 13 (SS 6) 1.90–2.00 mm	●	PP 33 (SS 17) 4.10–4.20 mm	●	SS 37 7.70–7.93 mm		
•	PP 14 (SS 6) 2.00–2.10 mm	●	SS 18 4.20–4.40 mm	●	SS 38 7.93–8.16 mm	●	SS 60 14.22– 14.47 mm
•	PP 15 (SS 7) 2.10–2.20 mm	●	SS 19 4.40–4.60 mm	●	SS 39 8.16–8.41 mm		
•	PP 16 (SS 7) 2.20–2.30 mm	●	SS 20 4.60–4.80 mm	●	SS 40 8.41–8.67 mm	●	SS 65 15.47– 15.72 mm
•	PP 17 (SS 8) 2.30–2.40 mm	●	SS 21 4.80–4.90 mm	●	SS 41 8.67–8.95 mm		
•	PP 18 (SS 8) 2.40–2.50 mm	●	SS 22 4.90–5.10 mm	●	SS 42 8.95–9.23 mm	●	SS 70 16.72– 16.97 mm
•	PP 19 (SS 9) 2.50–2.60 mm	●	SS 23 5.10–5.27 mm	●	SS 43 9.23–9.53 mm		
•	PP 20 (SS 9) 2.60–2.70 mm	●	SS 24 5.27–5.44 mm	●	SS 44 9.53–9.85 mm	●	SS 75 17.97– 18.22 mm

VALID FROM JULY 2014

Sys.No. 5104962

Content is subject to change without notice. Errors and misprints excepted.

D. Swarovski Distribution GmbH, Swarovskistrasse 30, 6112 Wattens, Austria

© 2014 D. Swarovski Distribution GmbH. All rights reserved. Partial or total publication, transmission, copy or other duplication of texts, graphics, pictures etc. which are to be found in this publication is forbidden without special consent by D. Swarovski Distribution GmbH.

Swarovski® is a registered trademark of Swarovski AG.

PRINTED by RWF Frömel-Hechenleithner Werbeges.m.b.H., Volders/Austria